

R Alagappan

Manual of Practical Medicine

Fourth Edition

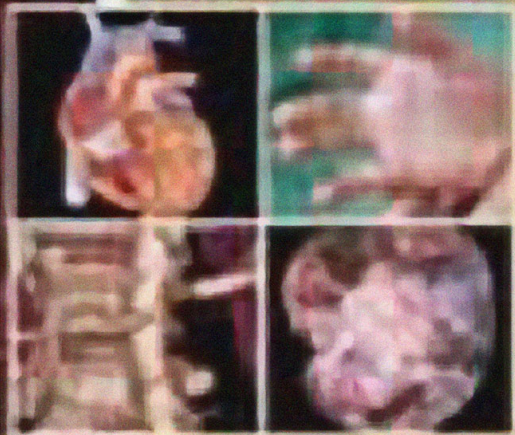

Download From: AghaLibrary.com

Ripped by
Dr. Prodigions

JAYPEE

Manual of Practical Medicine

Manual of Practical Medicine

Fourth Edition

R Alagappan MD FICP
Formerly Director
Professor and Head
Institute of Internal Medicine
Madras Medical College
and
Government General Hospital
Chennai, Tamil Nadu, India

Published by

Jitendar P Vij

Jaypee Brothers Medical Publishers (P) Ltd

Corporate Office

4838/24 Ansari Road, Daryaganj, **New Delhi** - 110002, India

Phone: +91-11-43574357, Fax: +91-11-43574314

Registered Office

B-3 EMCA House, 23/23B Ansari Road, Daryaganj, **New Delhi** - 110 002, India

Phones: +91-11-23272143, +91-11-23272703, +91-11-23282021, +91-11-23245672

Rel: +91-11-32558559, Fax: +91-11-23276490, +91-11-23245683

e-mail: jaypee@jaypeebrothers.com, Website: www.jaypeebrothers.com

Offices in India

- **Ahmedabad**, Phone: Rel: +91-79-32988717, e-mail: ahmedabad@jaypeebrothers.com
- **Bengaluru**, Phone: Rel: +91-80-32714073, e-mail: bangalore@jaypeebrothers.com
- **Chennai**, Phone: Rel: +91-44-32972089, e-mail: chennai@jaypeebrothers.com
- **Hyderabad**, Phone: Rel:+91-40-32940929, e-mail: hyderabad@jaypeebrothers.com
- **Kochi**, Phone: +91-484-2395740, e-mail: kochi@jaypeebrothers.com
- **Kolkata**, Phone: +91-33-22276415, e-mail: kolkata@jaypeebrothers.com
- **Lucknow**, Phone: +91-522-3040554, e-mail: lucknow@jaypeebrothers.com
- **Mumbai**, Phone: Rel: +91-22-32926896, e-mail: mumbai@jaypeebrothers.com
- **Nagpur**, Phone: Rel: +91-712-3245220, e-mail: nagpur@jaypeebrothers.com

Overseas Offices

- **North America Office, USA**, Ph: 001-636-6279734
e-mail: jaypee@jaypeebrothers.com, anjulav@jaypeebrothers.com
- **Central America Office, Panama City, Panama**
Ph: 001-507-317-0160, e-mail: cservice@jphmedical.com
Website: www.jphmedical.com
- **Europe Office, UK**, Ph: +44 (0) 2031708910
e-mail: info@jpmedpub.com

Manual of Practical Medicine

© 2011, Jaypee Brothers Medical Publishers

All rights reserved. No part of this publication should be reproduced, stored in a retrieval system, or transmitted in any form or by any means: electronic, mechanical, photocopying, recording, or otherwise, without the prior written permission of the author and the publisher.

This book has been published in good faith that the material provided by author is original. Every effort is made to ensure accuracy of material, but the publisher, printer and author will not be held responsible for any inadvertent error(s). In case of any dispute, all legal matters are to be settled under Delhi jurisdiction only.

First Edition: 1998

Reprint: 1998, 1999, 2000, 2001

Second Edition: 2002

Reprint: 2005

Third Edition : 2007

Reprint: 2009

Fourth Edition : **2011**

ISBN 978-93-80704-80-7

Typeset at JPBMP typesetting unit

Printed at Ajanta Offset

Download From: AghaLibrary.com

MEDICAL STUDENTS



Their thirst for knowledge make us learn

Preface to the Fourth Edition

The *Manual of Practical Medicine* provides the basic principles of clinical examination in addition to detailed history taking. The firm foundation in clinical methods will help the physicians in arriving at a provisional diagnosis and for planning relevant necessary investigations to confirm the diagnosis. The common and important clinical disorders are described in detail along with relevant investigations and updated management. New diagrams, tables and radiological images have been added in all the chapters.

The fourth edition is dedicated to the community of medical students whose thirst for knowledge make the teachers learn. Learning helps in the proper management of patients.

I profusely thank the postgraduate students Dr A Prabhakar and Dr S Karthikeyan for helping me in updating the fourth edition. I fully appreciate their hard work.

I offer my heartfelt thanks to Dr KG Srinivasan of KGS advanced MRI scan in providing me the necessary images and also in updating the chapter on Imaging Modalities in Internal Medicine.

I thank Mr P Ilango for doing the photoshop work for this edition.

I am deeply indebted to Shri Jitendar P Vij, Chairman and Managing Director, M/s Jaypee Brothers Medical Publishers (P) Ltd for his constant best wishes.

I also thank Mr Tarun Duneja, Director-Publishing, M/s Jaypee Brothers Medical Publishers (P) Ltd for his tremendous efforts in bringing out the fourth edition.

I do hope and wish that the updated edition with more number of diagrams and tables will be a good guide for both medical students and physicians.

R Alagappan

Preface to the First Edition

Medicine is an everchanging science. The vast clinical experience, the technological advancement in the field of investigatory modalities, tremendous explosion in the invention and addition of newer drugs in the field of pharmacology, and a wide variety of interventional therapeutic advancements have contributed to the voluminous growth of medical literature.

Human brain cannot remember all the facts. It is impossible to learn, register, remember and to recall all the medical facts in the course of time bound undergraduate and postgraduate medical education. It is the realization of these difficulties that prompted me to write this manual. Hence, an earnest attempt has been made to merge the clinical methods and the principles of internal medicine and to present both in a condensed form. To keep the size of the volume compact and small, only certain important clinical topics are included in this manual. Even references are not included since high-tech reference system is available in all the good libraries.

The manual will be of practical value to the medical students and practising physicians with an emphasis not only on clinical methods, clinical features, various essential investigations, but also on the management of various important clinical disorders.

I am deeply indebted to three of my postgraduate students Dr K Narayanasamy MD, Dr Rajesh Bajaj MD, and Dr S Sujatha MD who have helped me in preparation of the manuscript, computer and laser printing and upto the stage of submission to the publishers. But for their untiring efforts and hardwork, the timely publication of this manual would not have been possible.

I wish to acknowledge the contribution of my associates and colleagues in securing the clinical photographs, echocardiograms, X-rays, CT films, nuclear imaging photographs and computer line diagrams for this manual: C Lakshmikanthan, R Alagesan, P Thirumalai, K Kannan (Madurai), CU Velmurugendran, SG Krishnamoorthy, S Sethuraman, P Raja Sambandam, MA Muthusethupathy, P Soundarrajan, AS Natrajan, D Sivagnanasundaram, C Panchapakesa Rajendran, KR Suresh Bapu, Thirumoorthy and Hari Ramesh.

I wish to thank my postgraduate students who did the proofreading of the entire manual.

Last, but by no means the least, I wish to acknowledge the help and encouragement provided by the editorial department and the editorial staff of the Jaypee Brothers Medical Publishers for their kind cooperation in bringing out this manual.

I do wish that this manual will be a good guide and primer to the internal medicine students and practising physicians.

R Alagappan

Contents

1. Introduction to Internal Medicine	1
2. Nutrition	53
3. Cardiovascular System	77
4. Respiratory System	199
5. Abdomen	269
6. Haematology	341
7. Nephrology	395
8. Nervous System	427
9. Endocrine and Metabolic Disorders	605
10. Connective Tissue Disorders	695
11. Oncology	723
12. Geriatric Medicine	761
13. Substance Abuse	769
14. Imaging Modalities in Internal Medicine	781
15. Procedures	805
Laboratory Reference Values	823
<i>Index</i>	827

Chapter 1

Introduction to Internal Medicine

THE HISTORY

NAME

AGE (Date of birth)

SEX

ADDRESS

SOURCE OF HISTORY

PRESENTING COMPLAINTS

(in chronological order)

HISTORY OF PRESENTING COMPLAINTS

Duration/Severity

Mode of onset

Progression

Agg./Relieving factors

Associated symptoms

PAST ILLNESS

H/o past medical/
surgical illness

PERSONAL HISTORY

H/o smoking/alcohol use

H/o illicit drug use

Pre/extramarital contact

OCCUPATIONAL HISTORY

MARITAL STATUS

LIVING CIRCUMSTANCES

IN CHILDREN,

Prenatal/natal

Postnatal history

Developmental history

Immunisation history

DIET HISTORY

MENSTRUAL HISTORY

FAMILY HISTORY

DRUGS AND ALLERGIES

SUMMARY

THE PHYSICAL EXAMINATION

GENERAL EXAMINATION

Consciousness

Mental state

General appearance

Face and body habitus

Skin/Hair/Nails

Eyes-pallor

Icterus

Oral cavity

Dental hygiene

Hydration

Odour of breath

Cyanosis

Tongue

Clubbing

Pedal oedema

Lymph node enlargement

VITAL SIGNS

Temperature

Pulse

Respiration

Blood pressure

ANTHROPOMETRY

Height and weight

BMI

In children,

MAC and HC

SYSTEM EXAMINATION

(prioritise the system

which is involved)

Cardiovascular system

Respiratory system

Gastrointestinal system

Nervous system

WORKING DIAGNOSIS

INVESTIGATIONS

EXPLANATION TO

THE PATIENT

TREATMENT/FUTURE PLAN

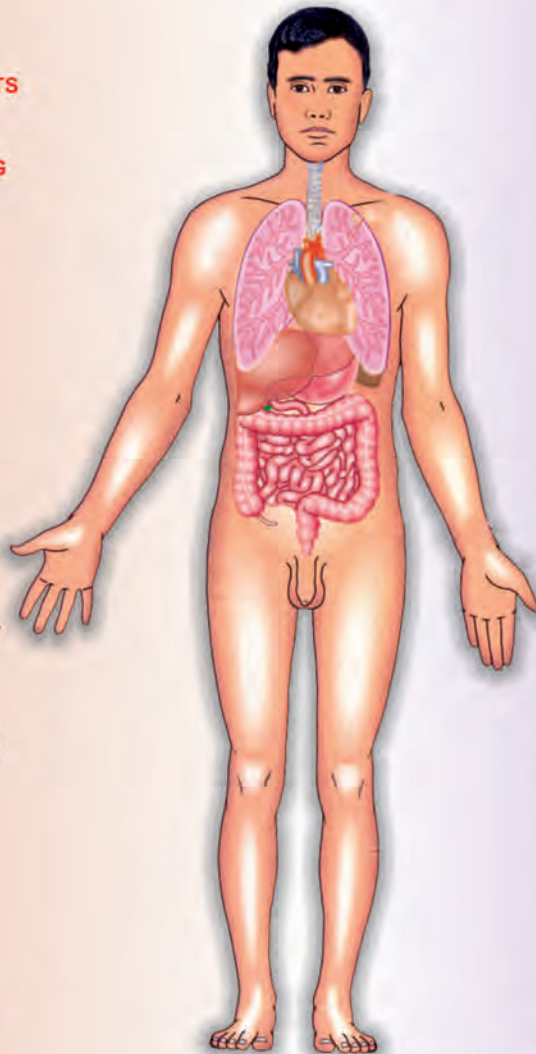



History Taking

History taking is an art, which forms a vital part in approaching the patient's problem, and arriving at a diagnosis. History taking helps to form a healthy doctor-patient relationship. It also builds up the patient's confidence and trust in his doctor.

Even before going into the patient's complaints, important facts can be gleaned from the following data, asked as a routine from every patient, helping the consulting doctor to arrive at a most probable conclusion to the patient's problems.

1. **Name:** Gives a clue to the country, state, and religion to which the patient may belong.

2. **Age:** Problems setting in at childhood are probably congenital in origin. Degenerative, neoplastic, and vascular disorders are more common in the middle aged or elderly. In women beyond the menopausal age group, the incidence of problems like ischaemic heart disease increases in equal proportion as that in their male counterparts.

3. **Sex:** Males are prone to inherit certain conditions transmitted as X-linked recessive diseases, e.g. haemophilia. They are more prone to develop conditions like IHD, bronchogenic carcinoma and decompensated liver disease, as they are habituated to smoking and consumption of alcohol, in larger numbers than their female counterparts. Females are more prone for developing autoimmune disorders like SLE, thyroid disorders, etc.

4. **Religion:** Jews practice circumcision soon after birth, and so development of carcinoma of penis is rare in them. Muslims do not consume alcohol, and so are less prone to develop problems related to its consumption, e.g. decompensated liver disease. Sikhs do not smoke and are less likely to develop problems related to smoking, e.g. carcinoma of lung. Certain sections of Hindus do not consume meat products and consume a high fibre diet and are therefore protected from developing carcinoma of the colon.

5. **Address:** People hailing from the urban region are prone to develop problems related to urbanisation like exposure to constant stress and atmospheric pollutants (industrial and vehicular) and problems developing consequent to this, e.g. IHD, COPD, interstitial lung disease, etc. Inhabitants of mountains or hilly regions may develop problems like primary pulmonary hypertension, may have a persistent patent ductus arteriosus (from childhood) or may be goitrous secondary to iodine deficiency. The particular place from which the patient hails may be endemic for certain diseases, e.g. fluorosis prevalent in certain pockets in Andhra Pradesh.

After having obtained the above details, the patient should be approached as follows:

1. Greet the patient, preferably by his name and start off the consultation with some general questions such as, "What can I do for you?", or "How can I help you?", or "What is the problem?"

2. *The presenting of complaints:* Allow the patient to tell his complaints in his own words. Do not put leading questions to the patient. The current complaints and their duration should be noted in a chronological order.

3. *History of present illness:* Allow the patient to elaborate on the story of his illness from its onset to its present state. Take care so as not to put any leading questions to the patient which may distort the patient's history. The doctor may, however, interrupt the patient to ask for the presence of 'positive' or 'negative' symptoms pertaining to patient's current problems. In analysis of the symptoms, it is important to consider the mode of onset of the illness (acute, subacute, or insidious) and the progression of the illness to the present state (gradually deteriorating, getting better, remaining the same or having remissions and exacerbations). A review of all the systems can be made by questioning the patient on the presence or absence of symptoms pertaining to a particular system.

4. *History of previous illnesses:* This should include all important previous illnesses, operations, or injuries that the patient might have suffered from birth onwards. The mode of delivery and the timing of attainment of the various developmental milestones in infancy may be important in some cases. It is always wise to be cautious while accepting readymade diagnosis from the patient like 'Typhoid fever', 'Malaria', etc. unless the patient has records of the mentioned illness. Tactful enquiry about sexually transmitted diseases and its treatment, when this is considered of possible relevance to the patient's problem, should be made.

History of a previous single painless penile ulcer with associated painless masses over the inguinal regions, occurring 3-4 weeks after exposure to a commercial sex worker, which may have healed subsequently with or without treatment with the formation of a residual papery or velvety scar over the penis indicates a previous affliction by syphilis. This is important, as syphilis in its tertiary form, later in life, can present with systemic manifestations, e.g. aortic aneurysm and regurgitation, tabes dorsalis.

History of white discharge per urethrum with associated dysuria, 2-3 days after exposure to a commercial sex worker indicates gonorrhoea. This is important as gonorrhoea can later lead to gonococcal arthritis or urethral stricture.

5. *The menstrual history:* The following enquiries are made:

- i. Age of menarche
- ii. Duration of each cycle
- iii. Regular or irregular cycles
- iv. Approximate volume of blood loss in each menstrual cycle
- v. Age of attainment of menopause
- vi. Post-menopausal bleeding.

6. *Obstetric history:* The following enquiries are made:

- i. Number of times the patient conceived
- ii. Number of times pregnancy was carried to term
- iii. Number of abortions (spontaneous or therapeutic)
- iv. Number of living children, their ages and the age of the last child delivered.
- v. The time interval between successive pregnancies/abortions.
- vi. Mode of delivery (vaginal, forceps assisted, or caesarean).
- vii. Development of oedema legs, hypertension or seizures in the antenatal or postnatal period (seizure within 48 hours of delivery is due to pregnancy induced hypertension, beyond 48 hours may be due to cerebral sinus thrombosis).
- viii. Presence of impaired glucose tolerance in the course of pregnancy or history of having given birth to a large baby may give a clue to the presence of diabetes mellitus in the patient.

7. *Treatment history:* This should include all previous medical and surgical treatment and also any medication that the patient may be continuing to take to the present date. Details of drugs taken, including analgesics, oral contraceptives, psychotropic drugs and of previous surgery and radiotherapy are particularly important. It is important to find out if the patient had been allergic or had experienced any untoward reactions to any medication that he may have consumed previously, so that the same medication can be avoided in the patient in future and the patient is also appraised of the same. Knowledge of any current therapy that the patient may be on is necessary in order to avoid adverse drug reactions, when new drugs are introduced by the consulting doctor.

8. *Family history:* Enquire about the presence of consanguinity in the patient's parents, any disease states in the patient's parents, brothers, sisters and close relatives (presence of disease states like HTN, DM, IHD in the above may make the patient more prone to develop a similar problem). It is prudent to record the state of health, important illnesses, the cause and age of

death in any member of the patient's family (may give a clue to the presence of HOCM, or development of IHD). Presence of a hereditary disorder prevalent in the family should be enquired for. Marital status of the patient and the number of children that the patient has should also be enquired for (infertility in a patient may give a clue to the presence of immotile cilia syndrome, cystic fibrosis or Young's syndrome).

9. *Social history:* Enquire about the patient's family life style, daily habits, and diet; about the nature of the patient's work (hard work or sedentary), as this may help in rehabilitation of the patient; about the possibility of over crowding at home (over crowding aids in the spread of communicable diseases) and the sanitation in and around the house; about the presence of pets in the house; about the use of alcohol (number of days in a week and also the quantity consumed each day), tobacco (whether chewed or smoked) and betel nut.

An alcoholic consumes alcohol almost everyday and develops withdrawal symptoms on abstaining from alcohol.

Smoking: Enquire about the number of cigarettes/beedis smoked per day and the duration of smoking. This may be presented as:

Pack years: Duration of smoking in years \times Number of packets of cigarettes smoked/day, e.g. two packs of cigarettes smoked per day for twenty years constitutes 40 pack years (Risk for development of bronchogenic carcinoma increases when pack years exceed 40).

Smoking index: It is the number of cigarettes or beedis smoked per day and its duration, e.g. the smoking index of a person smoking 20 cigarettes or beedis per day for 20 years is 400. Smoking index greater than 300 constitutes a risk factor for bronchogenic carcinoma.

Chewing betel nut or tobacco is a habit common with people living in the rural areas, and this increases the risk of developing oral malignancies.

Enquire about history of travel abroad or other places within the country, as it may give a clue to the import of a disease by the patient, endemic in the place visited.

10. *Occupational history:* Enquiry must be made on all previous and present occupation, as it may give a clue to the presence of an occupational disease in the patient and also to plan the rehabilitation, e.g.

- i. Mesothelioma—exposure to asbestos
- ii. Carcinoma of the urinary bladder—exposure to aromatic amines in dyestuff industry.
- iii. Silicosis—occurs in mine workers.

On the other hand, the presence of a disease in an individual may make him unfit for his occupation by proving to be hazardous to him as well as to others, e.g.

- i. Salmonella infection or carrier state in food handlers.
- ii. Epilepsy in drivers of public transport vehicles.

General Examination

Examination of the Skin

Pigmentation of the skin varies from dark skinned to fair individuals, depending on the race to which they belong.

- a. Generalised absence of skin pigmentation occurs in albinism. Syndromes with features of albinism are:
 - i. Chédiak-Higashi syndrome (phagocyte deficiency disease)
 - ii. Phenylketonuria (inborn error of amino acid metabolism).
- b. Patchy absence of skin pigmentation may be due to vitiligo (Fig. 1.1). In the presence of vitiligo, suspect presence of DM or other autoimmune disorders in that patient.



Fig. 1.1: Vitiligo

- c. Circumscribed hypopigmented lesions of the skin may occur in
 - i. Hansen's disease (Tuberculoid or Borderline Tuberculoid types).
 - ii. Tinea versicolor.
- d. Generalised hyperpigmentation of the skin is seen in
 - i. Haemochromatosis
 - ii. Endocrine disorders
 - Addison's disease
 - Cushing's syndrome
 - Ectopic ACTH production.

- e. Patchy hyperpigmentation of the skin is seen in
 - i. Pellagra (in parts exposed to sunlight)
 - ii. Porphyria Cutanea Tarda
 - iii. Scleroderma
 - iv. Café au lait spots* (Fig. 1.2)
 - v. Chloasma
 - vi. Butterfly rash over face in SLE
 - vii. Acanthosis nigricans
 - viii. Drugs—chlorpromazine, clofazimine, heavy metals like gold, bismuth
 - ix. Fixed drug eruptions.
- f. Yellow pigmentation of the skin:
 - i. Jaundice (there is yellowish discolouration of the skin, mucous membranes, and the sclera seen through the bulbar conjunctiva. This usually occurs when the total serum bilirubin value has exceeded 2 mg/dl).
 - ii. Carotenaemia (this occurs due to excessive ingestion of carotene. There is a yellowish discolouration of the skin and the mucous membrane, but there is no yellow discolouration of the sclera.
 - iii. Lemon yellow discolouration of the skin can occur in long standing severe anaemia.
- g. *Bluish discolouration*: Bluish discolouration of the skin, mucous membranes and sclera can occur in the presence of cyanosis. In peripheral cyanosis, the bluish

* Café au lait spots are macules, present in more than 90% of patients with neurofibromatosis (both types I and II). They appear as light brown round to ovoid macules, with smooth borders, often located over nerve trunks, their long axis being parallel to the underlying cutaneous nerve. Its presence is significant when 6 or more of these macules, each more than 1.5 cm in diameter, are present. Café au lait macules with irregular borders are present over the midline of the body and are seen in McCune-Albright syndrome (fibrous dysplasia).



Fig. 1.2: Café au lait macule

discolouration is seen only in the peripheries like the tips of the fingers and toes, tip of the nose and ear lobes. The sclera and the mucous membranes are not discoloured. In central cyanosis, the mucous membranes, e.g. the tongue, the lips, as well as the sclera and the peripheries show a bluish discolouration. Bluish discolouration simulating cyanosis can be seen with methaemoglobinaemia and sulphaemoglobinaemia.

h. *Ruddy complexion*: This complexion, whereby the patient has a reddish hue with a tinge of bluish discolouration is seen in patients with polycythemia vera, in whom there is an increased haemoglobin concentration.

i. *Pallor*: This complexion, in which the patient appears pale, is seen over the skin, mucous membranes, lower palpebral conjunctiva, finger nails and palms of the hands, indicating that the patient has anaemia. Loss of the pigmentation of the palmar creases of the hands gives a clue that the Hb may be less than 7 gm% in that patient.

j. Look for the presence of macules, papules, vesicles, pustules or scars, which may suggest the presence of exanthematous fever.

Segmental distribution of vesicles on an erythematous base, on one-half of the body, suggests a diagnosis of herpes zoster. Herpes zoster involving many segments simultaneously suggests an immunodeficiency disorder in the patient, e.g. AIDS, DM.

k. *Dermatographia*: Firm stroking of the skin results in a red linear elevation followed by a wheal, surrounded by a diffuse pink flare. This occurs in patients with allergic predisposition and urticaria. Dermatographism is also seen in carcinoid syndrome.

l. Some other important skin markers to be looked for in order to get a clue to the diagnosis in a patient are:

- i. Purplish striae over the lower, anterior abdominal wall in Cushing's syndrome.
- ii. Erythema marginatum in rheumatic fever.
- iii. Purpuras, ecchymosis are seen in purpuras (ITP, Henoch-Schönlein purpura), coagulation defects, leukaemias.
- iv. Adenoma sebaceum (Fig. 1.3) } Tuberous
Shagreen patch (Fig. 1.4) } sclerosis
Ash leaf macules
- v. Haemangiomas present externally may also be present in the CNS.
- vi. Telangiectasia—seen in ataxia telangiectasia. Multiple telangiectasias are seen in Osler-Rendu-Weber syndrome in which AV malformations are found in the lung, liver, CNS and mucous membranes.



Fig. 1.3: Adenoma sebaceum



Fig. 1.4: Shagreen patch

- vii. Spider naevi in decompensated liver disease, SVC obstruction.
- viii. Palmar erythema in decompensated liver disease, chronic febrile illness, chronic leukaemias, polycythaemia, rheumatoid arthritis, thyrotoxicosis, chronic alcohol intake and may also be seen in physiological states like pregnancy.
- ix. Erythema nodosum (Fig. 1.5)—This is a non-specific skin marker and may be seen in conditions like primary complex, sarcoidosis and with certain drugs.
- x. Multiple neurofibromas: von Recklinghausen's disease.
- xi. Xanthomas—Hyperlipidaemia.



Fig. 1.5: Erythema nodosum

- xii. Malignant tumours of the skin—Squamous cell carcinoma, basal cell carcinoma, malignant melanoma.
- xiii. Pigmentation of the mucous membrane of the oral cavity may be seen in Addison's disease, and also in Peutz-Jeghers syndrome (peri-oral pigmentation and polyposis of colon).
- xiv. A tuft of hair or a lipoma over the lower lumbar region in the back may indicate the presence of a spina bifida.
- xv. Diabetes mellitus
 - Necrobiosis lipoidica diabetorum (papulonodular lesions enlarging to form brownish-yellow plaques with waxy surface over the front of legs),
 - Diabetic dermopathy (dull red, oval, flat-topped papules over both legs),
 - Diabetic bullae (over legs, hands and feet bilaterally healing with atrophic scars),
 - Diabetic rubeosis (flushed skin of face),
 - Carotenoderma (yellowish tint of skin due to deposition of carotene),
 - Granuloma annulare (papular lesion over central areas of body and flexures of neck, arm and thigh),
 - Scleredema diabetorum (diffuse, waxy, nonpitting induration of skin particularly over back of neck and upper trunk),
 - Infections like furuncle, carbuncle, candidalparonychia, balanoposthitis, intertrigo, vaginitis and recurrent dermatophytosis.

- xvi. Chronic renal failure
 - Uraemic frost,
 - Erythema papulatum uraemicum (erythematous nodules over palms, soles and forearm),
 - Generalised pruritus,
 - Metastatic calcification,
 - Kyrle's disease (multiple discrete or confluent hyperkeratotic follicular papules over lower extremities),
 - Nail changes (half-half nail—proximal white and distal half pink, mees lines),
 - Oral manifestations (coating of tongue, xerostomia, ulcerative stomatitis).
- xvii. Internal malignancy
 - Acanthosis nigricans (Fig. 1.6) (adenocarcinoma of GIT),



Fig. 1.6: Acanthosis nigricans

- Palmo-plantar keratoderma (Ca bronchus and oesophagus),
- Necrolytic migratory erythema (glucagonoma),
- Pityriasis rotunda (hepatocellular Ca),
- Sign of Leser-Trelat (sudden eruption of intensely pruritic multiple seborrhoeic keratosis in Ca stomach),
- Migratory thrombophlebitis (Ca pancreas),
- Cutaneous hamartoma (Ca breast, thyroid, gastrointestinal polyposis-cowdens disease).

Hair

The scalp contains approximately 1,00,000 hairs. Each hair grows for about 1,000 days.

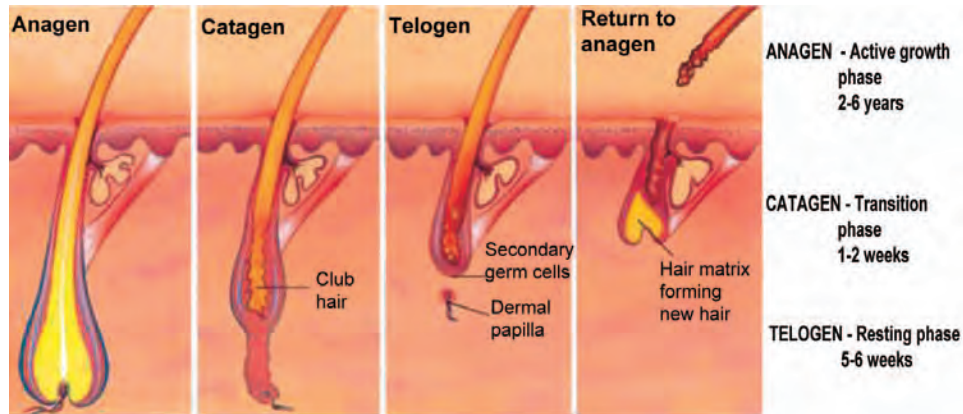

Fig. 1.7: Hair follicle growth stages

Rate of hair loss per day is approximately 100 normally.

Look for

- i. Presence and colour of scalp hair
- ii. Presence and distribution of hair over body (Secondary sexual character).

Stages of Hair Follicle Growth

Racial characteristics of hair colour and texture are determined genetically. The growth of hair is cyclic. Secondary sexual male (14-15 years) and female (12-13 years) pattern of hair appear at puberty. Adrenal androgen decides the growth of pubic hair and it occurs even in the absence of gonadotropin.

There are three different types of hair:

- Lanugo hairs – Fine long hairs covering the foetus and they are shed one month before full-term
- Vellus hairs – Fine short vellus hairs replace lanugo hairs
- Terminal hairs – They replace the vellus hairs on the scalp and the pubic vellus hairs are replaced by dark, curly hairs at the time of puberty.

There are three phases of hair growth. The duration of these phases vary in different regions of the body.

Axillary hair and facial hair in case of males grow 2 years after the appearance of pubic hair. The shape of hairs varies depending on the race.

- Asians – straight hair
- Mongoloids – sparse facial and body hair
- Negroids – curly hair
- Europeans – wavy hair

Temporal recession and baldness are common in males and the process is androgen dependent. Temporal recession in female may suggest virilization. Frontal baldness is a marker for myotonic dystrophy and also seen in some cases of systemic lupus erythematosus.

Phases of Hair Growth (Fig. 1.7)

1. Anagen phase – It is the actively growing phase and in the case of scalp, it lasts for 3-5 years.
2. Catagen phase – It is the conversion stage from active to resting and it lasts for a few weeks.
3. Telogen phase – It is the resting stage lasting for a few months and is replaced by anagen phase.

The length of anagen phase determines the length of the hair. Normally 85% of scalp hairs are in anagen phase and the remaining 15% are in telogen phase. The anagen phase is shorter and the telogen phase is longer in eyebrows and sexually determined hair.

Types of Alopecia (Loss of Hair)

Cicatricial Alopecia

- a. Trauma
- b. Burns
- c. Infections: folliculitis, herpes zoster, gumma, lupus vulgaris
- d. Morphea, lichen planus, sarcoidosis, DLE
- e. Cutaneous neoplasms: basal cell Ca
- f. Drugs—mepacrine.

Non-cicatricial Alopecia

- a. Alopecia areata (Fig. 1.8) (most common): It is an autoimmune disease characterised by single or multiple areas of alopecia without inflammation. If it involves the whole of scalp it is called alopecia totalis and the whole of body is called alopecia universalis. It is associated with other autoimmune diseases like SLE, vitiligo, autoimmune thyroiditis and autoimmune haemolytic anaemia.
- b. Physiologic: Androgenic alopecia is an autosomal dominant male pattern baldness. The early change is a bilateral frontal recession of the hairline. This



Fig. 1.8: Alopecia areata



Fig. 1.9: Virilisation

pattern is usually familial. 5-alpha reductase inhibitor finasteride is useful in the treatment. Other causes are puberty, pregnancy and neonatal period.

- c. Systemic diseases: SLE, hyperthyroidism, hypothyroidism, acrodermatitis enteropathica, pernicious anaemia and Down's syndrome.
- d. Infection: Moth eaten type in syphilis and fungal infections.
- e. Drugs: Antimetabolites, cytotoxics, heparin, carbimazole, iodine, bismuth, vitamin A, allopurinol and amphetamines.
- f. Telogen effluvium: Systemic illness (typhoid, measles, pneumonia) post-partum and post-surgical.
- g. Radiation.

Colour of Hair

- White hair albinism (due to absence of pigment).
- Grey hair is a sign of ageing.
- Poliosis patchy loss of pigmentation of hair in the region of an adjoining vitiligo.
- Flag sign brownish discolouration of hair, with interspersed normal colour of hair, is seen in protein energy malnutrition.



Causes of Hypertrichosis (Excess Hair)

- i. Familial
- ii. Sexual precocity
- iii. Hypothyroidism
- iv. Adrenal hyperplasia or neoplasm

- v. Virilising ovarian tumours (Fig. 1.9)
- vi. Drugs (Androgens, Minoxidil).
- vii. Hirsutism (male distribution of hair in females).

Decreased Body Hair Distribution (Loss of Secondary Sexual Character)

This is seen in the following conditions:

- i. Decompensated liver disease
- ii. Klinefelter's syndrome
- iii. Bilateral testicular atrophy as seen in Hansen's disease.

Face

Forehead

Prominent Forehead

This is seen in:

- i. Acromegaly
- ii. Chronic hydrocephalus
- iii. Frontal balding as seen in myotonic dystrophy
- iv. Rickets
- v. Thalassaemia.

Wrinkling of Forehead

- i. Bilateral wrinkling of the forehead is seen in anxiety states or in the presence of bilateral ptosis as in Myasthenia Gravis, bilateral third nerve palsy or bilateral Horner's syndrome.
- ii. Unilateral wrinkling of forehead is seen on the side of unilateral ptosis, as in unilateral third nerve palsy or Horner's syndrome.

Absence of Wrinkling of Forehead

- i. Unilateral absence of wrinkling of forehead is seen in Bell's palsy, on the affected side.
- ii. Bilateral absence of wrinkling of forehead is seen in myotonic dystrophy and in hyperthyroidism (Joffroy's sign).

Hypertelorism

This means the presence of wide spaced eyes. This is diagnosed when the inter inner canthal distance between the two eyes is more than half of the inter pupillary distance (Fig. 1.10).



Fig. 1.10: Hypertelorism

Low Set Ears

An imaginary horizontal line is drawn from the outer canthus of the eye to the pinna of the ear on the same side. Normally about 1/3rd of the total length of the pinna is seen above the line. If less than 1/3rd of the total length of the pinna is seen above the line in a patient, he is said to have low set ears.

A prominent crease seen over the lobule of the pinna is a marker for development of ischaemic heart disease.

High Arched Palate

This is said to be present when the roof of the palate is not seen when the examiner's eyes are kept at level with the patient's upper incisor teeth, with the patient's mouth wide opened or 3 cm above an imaginary line joining the upper incisor teeth and uvula.

It is also said to be present when the roof of the palate extends above an imaginary line drawn connecting the two malar prominences.



Fig. 1.11: Unilateral ptosis

Eyes

Look for the following features when examining the patient's eyes:

1. Ptosis (unilateral or bilateral) (Figs 1.11 and 1.12)



Fig. 1.12: Bilateral ptosis

2. Pallor
3. Cyanosis
4. Icterus
5. Bitot's spots (vitamin A deficiency)
6. Phlyctenular conjunctivitis (may give a clue to presence of PT)
7. Arcus senilis (gives a clue to the presence of atherosclerosis) (Fig. 1.13)

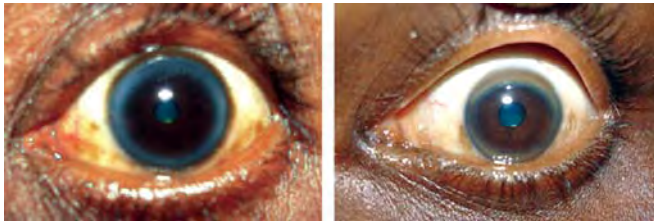

Arcus senilis

Kayser-Fleischer ring

Fig. 1.13



Fig. 1.14: Blue sclera (Osteogenesis imperfecta)

8. KF ring (Fig. 1.13) is seen in Wilson's disease, primary biliary cirrhosis, cryptogenic cirrhosis, intraocular copper foreign body (uniocular KF ring), carotenaemia

<i>Arcus senilis</i>	<i>KF ring</i>
1. Greyish white in colour	Yellowish green in colour
2. Present just internal to the limbus	Present on the limbus
3. A clear zone of iris seen in between the limbus and the ring	No zone of iris seen in between limbus and the ring
4. Due to deposition of calcium and lipids on the cornea	Due to deposition of copper on the Descemet's membrane of the cornea
5. Seen in middle to old aged people	Seen in the young
6. Its presence suggests a possible presence of atherosclerosis or hyperlipidaemia in the patient	Its presence suggests the presence of Wilson's disease
7. It is a complete ring	The ring is incomplete initially, appearing first in the superior aspect of the limbus, then progressing to appear in the temporal aspect, then inferiorly and finally medially
8. It is seen well with the naked eye	Confirmation of its presence may require a slit-lamp examination
9. It does not disappear at all	It disappears with treatment, disappearance being in the same pattern as its appearance.

9. Corneal opacities may be drug induced, e.g. Amiodarone or due to storage disorders
10. Cataract (early formation of cataract may be due to hypoparathyroidism, hyperparathyroidism, diabetes mellitus or prolonged oral steroid intake)
11. Subconjunctival haemorrhage (may be seen in whooping cough or leptospirosis)
12. Corneal ulcers (seen in Bell's palsy and in trigeminal nerve palsy)
13. Enlargement of the lacrimal glands (Sjögren's syndrome)
14. Ectopia lentis (upward subluxation of lens may be seen in Marfan's syndrome, whereas downward subluxation of the lens may be seen in homocystinuria)
15. Blue sclera (Fig. 1.14).

The Tongue

The tongue is often red with prominent papillae—fungiform papillae over the edges and the tip, filiform papillae over the centre, and the circumvallate papillae set in a wide 'V' shape with its apex pointing backwards separating the anterior 2/3 from posterior 1/3. The tongue aids in appreciating the various types of taste of food and also helps in the process of mastication. Note the colour, size, shape, coating, surface, mobility and local lesions.

Macroglossia

- Down's syndrome
- Acromegaly
- Myxoedema
- Amyloidosis
- Angioedema
- Tumours

Microglossia

- Pseudobulbar palsy
- Facial haemiatrophy
- Marked dehydration
- Starvation

Colour (Fig. 1.15)

- Blue tongue – central cyanosis
- Brown tongue
Uraemia
Acute liver necrosis
- White tongue
Centrally coated (enteric fever)
Leukoplakia
Excessive furring
- Scarlet red tongue – Niacin deficiency
- Dark red tongue



Fig. 1.15: Pallor of tongue

- Polycythemia
- Riboflavin deficiency
- Black tongue
- Melanoglossia
- Bismuth
- Iron
- Antibiotics like penicillin
- Slate blue tongue – Haemochromatosis
- Abnormal pigmentation – brownish black tongue
- Addison's disease
- Nelson's syndrome
- Peutz-Jeghers syndrome
- Chronic cachexia
- Malnutrition

Dryness of tongue

- Dehydration
- Haemorrhage
- Mouth breathing
- Uraemia
- Coma
- Atropine/belladonna
- Sjögren's syndrome

Ulcers

Single

- Tuberculosis
- Carcinoma
- Syphilis
- Dental irritation

Multiple

- Aphthous ulcers

- Herpes
- Secondary syphilis
- Pemphigus
- Chickenpox
- Vitamin B deficiency

Recurrent

- Aphthous ulcers
- SLE
- Coeliac disease
- Behçet's syndrome
- Lichen planus
- Pemphigus
- Neutropenia

Fissured Tongue (Scrotal) (Fig. 1.16)

- Down's syndrome
- Vitamin B deficiency
- Acromegaly
- Congenital malformation



Fig. 1.16: Fissured tongue

Geographic Tongue (Fig. 1.17)

Asymptomatic inflammatory condition with rapid loss and regrowth of filiform papillae leading to denuded red patches 'wandering' across the surface of the tongue – no clinical significance.

Hairy Leukoplakia (Fig. 1.18)

It is caused by EB virus and is typically seen in the lateral margin of the tongue and is diagnostic of AIDS.

Hairy Tongue (Fig. 1.19)

Formation of keratin layer prior to desquamation can result in elongation of filiform papillae over the medial dorsal surface of the tongue.



Fig. 1.17: Geographic tongue



Fig. 1.18: Oral hairy leukoplakia



Fig. 1.19: Black hairy tongue

Median Rhomboid Glossitis (Fig. 1.20)

It is red due to depapillation of rhomboid area at the centre of the dorsum of the tongue with associated candidiasis. It is marker of immune deficiency disorders.



Fig. 1.20: Median rhomboid glossitis

Bald Tongue (Irons out Tongue)

It is due to the diffuse atrophy of the papillae. It is commonly seen in pellagra, xerostomia and iron/B₁₂ deficiency disorders.

Tongue in Neurology

Fasciculation (fibrillation) within the tongue when lying in the oral cavity is a feature of motor neurone disease and also occurs in syringomyelia. Wasting of half of the tongue is due to hypoglossal nerve palsy and it deviates to the same side on protrusion. Myotonia can be better demonstrated in the tongue in myotonic dystrophy. Spastic tongue is due to pseudo-bulbar palsy.

Characteristic Types of Facies (Fig. 1.21)

1. *Acromegalic facies*: Prominent lower jaw, coarse features, large nose, lips, ears, prominent forehead and cheek bones and widespread teeth.
2. *Cushing's syndrome*: Rounded 'moon face' with excessive hair growth.
3. *Hypothyroid face*: Puffy face with a dull expression with swollen eyelids and loss of hair over eyebrows.
4. *Hyperthyroid face*: Anxious look with widely opened eyes with the upper and lower limb seen, associated with infrequent blinking and absence of wrinkling of the forehead.
5. *Leonine facies*: Seen in leprosy, and shows thickening of the skin and ear lobes with a flattened nasal bridge and loss of hair over the lateral aspect of eyebrows and eyelashes (madarosis).
6. *Elfin facies*: This is seen in supravalvular aortic stenosis, or pulmonary artery stenosis (William's syndrome). There is a presence of a wide mouth with large lips (pouting effect), widely spaced



Fig. 1.21: Facies in medicine

teeth, broad forehead, pointed chin, protruding ears and eyes set wide apart.

7. *Congenital pulmonary stenosis*: A broad face with eyes set wide apart (moon face).
8. *Face in pneumonia*: In lobar pneumonia, the alae nasi are over active, eyes bright and shiny, and herpetic lesions may be present over the angles of the mouth.
9. *Face in COPD*: Anxious look with bluish discolouration of lips, tip of the nose, ear lobes and breathing out through pursed lips.
10. *Face in nephrotic/nephritic syndrome*: Face is puffy with periorbital oedema and pallor.
11. *Face in scleroderma*: Skin over the face is taut and shiny. Patient finds difficulty in opening his mouth or to smile (microstomia).
12. *Face in SLE*: Seen predominantly in women. There is a butterfly rash seen over the face encompassing the upper cheeks and the nasal bridge. Erythema may be seen over the rash on exposure to sunlight.
13. *Face in Sjögren's syndrome*: There is enlargement of the lacrimal gland on both sides along with enlargement of the parotid and submandibular glands on both sides.
14. *Myasthenic facies*: Bilateral ptosis with outward deviation of the eyes, wrinkling of the forehead and partially opened mouth.
15. *Myotonic dystrophy*: Bilateral ptosis with absence of wrinkling of the forehead, frontal baldness with absent sternomastoids and bilateral cataract. Presence of a transverse smile is also characteristic of this condition.
16. *Parkinsonian face*: Immobile, fixed and expressionless face with infrequent blinking of the eyes. Normal rate of blinking is about 20 per minute. In Parkinsonism, the rate of blinking is reduced to less than 10 per minute. On closing the eyes, fluttering of the eyelids is seen (blepharoclonus). In post-encephalitic parkinsonism, oculogyric crisis (tonic upward deviation of the eyes) may be seen. A jaw tremor may also be seen.
17. *Bell's palsy*: Absence of wrinkling of forehead on the side of the lesion, along with inability to close the eyes, and on attempting to do so the eyeball is seen to move upwards and outwards (Bell's phenomenon). There is also loss of the naso-labial fold on the side of lesion and deviation of the angle of the mouth to the opposite healthy side on smiling. However, in long standing Bell's palsy, when contractures of the facial muscles develop,

prominent naso-labial grooves may be seen on the affected side, creating confusion as to the side of lesion.

18. *Cirrhotic facies*: Sunken cheeks and eyes with malar prominence and presence of bilaterally enlarged parotid glands (esp. in cirrhosis secondary to alcoholism).
19. *Cretinoid face*: Face is pale and has a stupid and dull look. Nose is broad and flattened. Lips are thick and separated by a large and fissured protruding tongue. Hair on eyebrows, eyelashes and scalp are scanty. Presence of prominent medial epicanthal folds and low set ears.
20. *Tabetic facies*: Partial ptosis with wrinkling of forehead and unequal, small and irregular pupils.

Constitution

Constitution indicates the body type or habitus. Human race can be classified into the following somatotypes.

Clinical Classification

- i. Asthenic—Thin, long and underdeveloped body with long neck, flat chest and slender fingers. They have a vertical heart. They are prone to have neurasthenia and visceroptosis.
- ii. Normosthenic—Normal average body build.
- iii. Sthenic—Broad, short, fat neck, muscular chest and large stumpy fingers. They have horizontal heart.

Anthropometric Classification

- i. Endomorph—Soft, round contours with well-developed cutaneous tissues, and short stature.
- ii. Mesomorph—Wide, stocky, muscular individual and normal stature.
- iii. Ectomorph—Long narrow hands, long feet, shallow thorax, small waist and tall stature.

Stature

Stature is total height measured from vertex of head to the soles of the feet. It is a sum total of upper segment measurement (from vertex of head to the upper border of symphysis pubis) + lower segment measurement (from top of symphysis pubis to soles of the feet).

Arm span: It is the distance between the tips of the middle fingers of the two hands, with both the arms held outstretched horizontally outwards from the body.

1. Normally the relationship between arm span and stature (height) varies according to age as follows:

Age	Arm span minus height (in cm)
a. 0–7 years	–3
b. 8–12 years	0
c. More than 12 years	+1 (in females) +4 (in males)

2. The relationship between upper segment measurement (from vertex to symphysis pubis) and lower segment measurement (from symphysis pubis to the heel) also varies with age as follows:

Age	Upper segment/lower segment
a. At birth	1.7
b. 3 years	1.4
c. 10 years	1.0
d. Adult	0.8

Stature > Arm Span

1. Adrenal cortex tumour
2. Precocious puberty.

This is because of early epiphyseal fusion.

Arm Span > Stature

1. Eunuchoidism
2. Hypogonadism
3. Marfan's syndrome
4. Homocystinuria
5. Klinefelter's syndrome.

This is because of delayed epiphyseal fusion. The difference in measurement must be greater than five centimeters to be significant.

Upper Segment > Lower Segment

1. Adrenal cortex tumour
2. Precocious puberty.

Lower Segment > Upper Segment

1. Eunuchoidism
2. Hypogonadism
3. Homocystinuria
4. Klinefelter's syndrome
5. Marfan's syndrome.

Marfan's Syndrome

It is a syndrome comprising of the following tetrad:

1. Familial (autosomal dominant)
2. Lens dislocation (upward)

Marfan's syndrome	Homocystinuria
1. It is a connective tissue disorder	It is an inborn error of metabolism, due to lack of the enzyme cystathionine synthase, leading to an accumulation of homocystine and methionine and a deficiency of cystathionine and cystine
2. It is transmitted as an autosomal dominant trait	It is transmitted as an autosomal recessive trait
3. Mental faculty normal	Mental defect is present
4. Bones are normal	Osteoporosis is present
5. Mitral valve prolapse and dilatation of the aortic root and sinus of Valsalva may be present	Medial degeneration of the aorta and elastic arteries may be present
6. There is no predilection to development of thrombosis	Arterial and venous thrombosis can occur
7. Supero lateral subluxation of the lens.	Infero lateral subluxation of the lens.

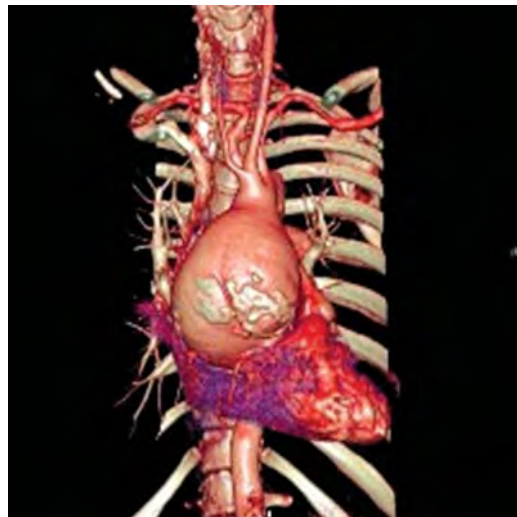

Fig. 1.22: Sino tubular ectasia and ballooning of aortic root

3. Great vessel (aortic or pulmonary) dilatation or dissection (Fig. 1.22)
4. Long tubular bones.

Skeletal Defects

- a. Stature—Tall and thin (asthenic)
- b. Skull—Dolicocephalus
- c. High arched palate
- d. Chest and spine—Pectus carinatum, pectus excavatum, straight back syndrome, kyphosis, scoliosis
- e. Limbs—Long thin limbs and long thin fingers (Arachnodactyly)



Fig. 1.23: Wrist sign



Fig. 1.24: Thumb sign

- f. Joint hypermobility and ligament laxity
- g. Feet—Pes planus, pes cavus, hallux valgus.

Wrist sign (Fig. 1.23): The patient with Marfan's syndrome is able to enclose his wrist with the thumb and little finger of the other hand, and the digits will overlap. The little finger overlaps the thumb by at least 1 cm.

Thumb sign (Fig. 1.24): In a patient with Marfan's syndrome, a part of the distal phalanx of the thumb is seen beyond the ulnar border of the hand, when a fist is formed with the thumb flexed, within the palm.

Height and arm span: The patient is tall, the lower segment being more than the upper segment by at least 5 cm. The arm span is more than the height of the patient by at least 5 cm.

Ocular Defects

- a. Micro cornea
- b. Ectopia lentis (Bilateral upward and outward dislocation)

- c. Cataract
- d. Strabismus
- e. Myopia
- f. Retinal detachment
- g. Iridodonesis.

Cardiac Defects

- a. Aneurysm of aorta
- b. Dissection of aorta
- c. Sinus of Valsalva aneurysm
- d. Aortic regurgitation
- e. Mitral or tricuspid valve prolapse syndrome
- f. Atrial septal defect (ostium secundum)
- g. Ventricular septal defect
- h. Dilatation of the pulmonary artery.

Pulmonary Defects

- a. Cystic bronchiectasis
- b. Spontaneous pneumothorax.



Investigations

1. Slit-lamp examination of the eyes for detection of ectopia lentis
2. X-ray of the hands.

Metacarpal index (MCI): This is calculated by measuring the average length of the second, third, fourth and fifth metacarpals, and the average midwidth of the same.

$$\text{MCI} = \frac{\text{average length of the four metacarpals}}{\text{average midwidth of the four metacarpals}}$$

If MCI is > 8.4, it indicates presence of Marfan's syndrome (Normal MCI = 5.4 to 7.9).

Gigantism

Gigantism is said to be present in an individual, when his height exceeds six feet, six inches.

Types of Gigantism

1. **Hereditary (Primary or genetic):** In this type, the body is perfectly proportioned. They are normal mentally, physically and sexually.
2. **Endocrine gigantism:** The following types are seen:
 - a. **Hyperpituitary gigantism:** They are well-proportioned and have good physical and sexual development.
 - b. **Eunuchoid gigantism:** They are tall, lanky and long limbed individuals with infantile sex organs, e.g. Klinefelter's syndrome.

Dwarfism

Dwarfism is said to be present when there is a marked, permanent shortness of stature, with predicted adult

height less than 4 standard deviations from the mean. An adult may be called a dwarf, if his height is less than 4 feet.

Classification of Short Stature

- I. *Normal variant*
 1. Familial short stature
 2. Constitutional growth delay
 3. Racial.
- II. *Pathological*
 - a. *Proportionate*
 - i. *Prenatal*
 1. Intrauterine growth retardation
 2. Antenatal infection in mother (TORCH*, syphilis, AIDS)
 3. Antenatal consumption of alcohol, tobacco, heroin
 4. Chromosomal disorders (Down's syndrome, Turner's syndrome).
 - ii. *Postnatal*
 1. Malnutrition (Protein-energy malnutrition, anorexia nervosa)
 2. Endocrine disorders (growth hormone deficiency, hypothyroidism, congenital adrenal hyperplasia, precocious puberty)
 3. Cardiovascular disorders (cyanotic and acyanotic congenital heart disease, early onset rheumatic heart disease)
 4. Respiratory disorders (Kartagener's syndrome, cystic lung disease, childhood asthma)
 5. Renal disorders (renal tubular acidosis, renal rickets, nephrotic syndrome, chronic pyelonephritis)
 6. Blood disorders (chronic anaemia like thalassemia or sickle cell anaemia, leukaemia)
 7. Psychosocial disorders (maternal deprivation).
 - b. *Disproportionate*
 1. Rickets
 2. Skeletal dysplasia (kyphosis, lordosis, scoliosis)
 3. Defective bone formation (osteopetrosis, osteogenesis imperfecta)
 4. Defective cartilage growth (achondroplasia, multiple cartilagenous exostosis)
 5. Defective bone matrix (fibrous dysplasia)
 6. Inborn errors of metabolism (mucopolysaccharidosis)

7. Calcium and phosphorus metabolism defects (hyperphosphatemic rickets)
8. Mineral metabolism defects (Wilson's disease, zinc deficiency).

Short Stature—Causes

1. Hereditary	Constitutionally small
2. Genetic	Down's syndrome, Turner's syndrome, Achondroplasia
3. Nutritional	Intrauterine growth retardation, protein and energy deprivation, Rickets
4. Endocrine	Cretinism, Hypopituitarism, Craniopharyngioma
5. Alimentary	Malabsorption syndromes, Crohn's disease, Cystic fibrosis
6. Cardio-respiratory	Congenital heart disease, suppurative lung disease
7. Locomotor	Severe scoliosis
8. Miscellaneous	Chronic wasting diseases including renal failure and biliary diseases

State of Nutrition

The state of nutrition depends mainly on the distribution of adipose tissue in the body. On this basis individuals can be classified as normal, overweight (fat or obese) and underweight.

The state of nutrition can be assessed in the following ways:

1. Ideal body weight (IBW) = $22.5 \times (\text{height in metres})^2$
In women, the ideal body weight is calculated as follows:
 $0.94 \times 22.5 \times (\text{height in metres})^2$
If the body weight > 10% of IBW, the individual is overweight
If the body weight > 20% of IBW, the individual is obese.
2. Body mass index (BMI) is calculated as follows:
 $\text{BMI} = \text{weight in kg} / (\text{height in metres})^2$
The normal range of BMI is 19–25
In males, it is 20–25
In females, it is 18–23
If BMI is between 25 and 30, the individual is overweight.
If BMI > 30, the individual is obese.

Grading of Obesity

- | | |
|-----------|---------------------------|
| Grade I | if BMI 25–30 (overweight) |
| Grade II | if BMI 30–40 (obese) |
| Grade III | if BMI > 40 (very obese) |
3. The amount of subcutaneous fat can be estimated by measuring the skinfold thickness over the triceps, biceps, subscapular region and suprailiac region, by using a special pair of calipers. Equations and

* Toxoplasmosis, other infections Rubella, Cytomegalovirus, Herpes simplex.

nomograms are available for conversion of skin fold thickness to body fat. (Normal triceps skin fold thickness: Adult males—12.5 mm; Adult females—16.5 mm).

- Rough calculation of body weight (Broca's index) can be done provided the height of the individual is > 100 cm, and so is possible in adults only.
Height in cm - 100 = desired body weight (in kg).
Height in inches = body weight (in kg).

Obesity

A person is said to be obese, if his body weight > 20% of IBW and his BMI > 30.

Types of Obesity

- Generalised obesity*: There is excess fat deposition uniformly throughout the body. Over eating is the most common cause. It is characterised by the presence of a 'double chin'.
- Android obesity (Fig. 1.25A)*: It is a type of obesity, which is characterised by excess deposition of fat over the region of the waist.
- Gynoid obesity (Fig. 1.25B)*: It is a type of obesity, which is characterised by excess deposition of fat over the region of the hips and thighs.
- Superior or central type of obesity*: In this type, there is excess fat deposition over face, neck and upper part of the trunk and the arms are thin. This is seen in Cushing's syndrome.

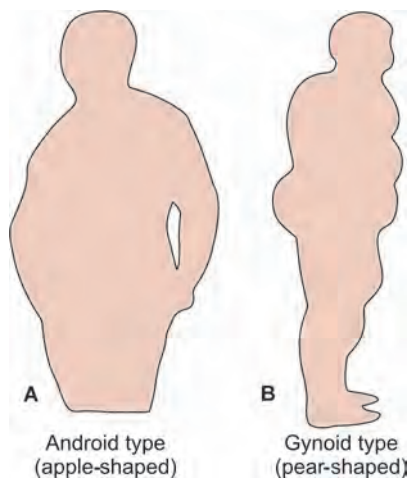

Figs 1.25A and B: Pattern of obesity

Recent evidence suggests that regional distribution of fat may be of greater prognostic significance than absolute degree of obesity. This is assessed by measuring the hip : waist ratio.

The hip measurement is taken by measuring at a level that gives the maximal measurement of the hip, over the buttocks.

The waist is measured by taking a circumference that gives the narrowest measurement between the ribcage and the iliac crest.

Waist-hip ratio	Type of obesity	Prognosis
1. 0.8 or less	Pear-shaped obesity	Good
2. 0.9 or greater	Apple-shaped obesity	Greater risk of developing complications of obesity

Under Weight

Adults are significantly under weight if their BMI is 18 or less. Causes for weight loss:

- Malnutrition
- Grief or depression
- Thyrotoxicosis
- Diabetes mellitus
- Addison's disease
- Tuberculosis
- HIV infection
- Chronic bronchitis
- CCF
- Malignancy
- Malabsorption syndromes
- Anorexia Nervosa (This is diagnosed when the weight of the patient is < 25% of his IBW).

Posture

The position or attitude constantly assumed by a patient at rest or in motion is referred to as posture. The posture of a patient, when viewed from the side, may be characteristic enough to suggest a diagnosis.

The various postures seen in clinical practice are:

- Postures seen when the patient is standing/sitting.
 - Vertical line seen in standing posture, when viewed from the side, is a good posture.
 - Standing posture, when it assumes a S-shaped curve, when viewed from the side, is a poor posture.
 - Asthenic posture*: The normal curves of the spine are exaggerated. Seen in debility, wasting and in senility.
 - Parkinsonian posture*: Universally flexed posture.
 - Lordotic posture*: There is an exaggerated lumbar lordosis. Seen in muscular dystrophy, due to proximal muscle weakness. It is also seen in bilateral hip problems.

- f. *Cerebellar posture*: In lesions of the cerebellum or its connections, the patient stands with his feet wide apart, and is unable to maintain a steady posture when standing with both his feet placed close together. Patient is ataxic on sitting (truncal ataxia) when the vermis of the cerebellum is involved.
- g. *Posture in ankylosing spondylitis*: There is loss of the lumbar lordosis, with an exaggeration of the upper thoracic kyphosis.
- h. *Catatonic posture*: In this, the patient maintains a particular posture of the body and limb for hours together. This is seen in schizophrenia.
2. Postures seen when the patient is lying down:
- a. *Decerebrate posture*: Extension of elbows and wrists, with pronation of the arms is seen. It suggests that the lesion is at the brainstem level, disconnecting the cerebral hemispheres from the brainstem.
- b. *Decorticate posture*: Flexion of elbows and wrists, with supination of the arms is seen. It suggests severe bilateral hemispherical damage above the midbrain.
- c. *Hemiplegic posture*: The patient lies on his back, with the cheek on the affected side blowing out with each expiration. The affected upper limb lies flaccidly by his side, and the affected lower limb is externally rotated. This picture is seen immediately after the onset of haemiplegia. In long standing haemiplegia, there may be loss of naso-labial fold of the face on the side of the paraesis, with the affected upper limb in a flexed posture and the affected lower limb in an extended posture.
- d. *Opisthotonus*: In this posture, the patient is arched up like a bow, with his heel and occiput in contact with the bed. This posture is seen in patients with tetanus and strychnine poisoning.
- e. Lateral decubitus posture with curled up limbs to minimise the stretching of the meninges, is seen with meningitis or meningism.
- f. Patient lying up with a back rest or cardiac rest suggests a possibility of the patient having CCF or COPD.
- g. Patient sitting up and holding on to a support before him, in order to fix his shoulders, and having dyspnoea, suggests a diagnosis of bronchial asthma.
- h. Patient lying down still and
- i. Clutching his chest—anginal chest pain
 - ii. Shallow breathing, with minimal or no movement of the anterior abdominal wall—peritonitis.
- i. Patient rolling about in the bed from side to side and
 - i. Clutching his chest—Myocardial infarction.
 - ii. Holding his upper abdomen—Biliary colic.
 - j. Patient sitting up and bending forwards, may be seen in
 - i. Pericarditis
 - ii. Pancreatitis
 as the pain caused by both these conditions is relieved by assuming this posture.
 - k. *Prone posture*: Patient preferring to lie in the prone position than in the supine position may be due to the presence of an abdominal aortic aneurysm which may erode on the vertebra in the supine posture and cause back pain. On lying prone the aorta falls forward from the vertebra and the pain subsides.

Hands and Fingers

Hands

- i. *Cretinism*: Square palm, short, fat and blunt fingers and short radius.
- ii. *Down's syndrome*: Short and thick hand. Short thumb arising at a level lower than normal from the palm with incurving of the distal phalanx of the little finger (clinodactyly) (Figs 1.26 and 1.27) and a single palmar crease is seen over the palm (Fig. 1.28).
- iii. *Acromegalic hand* (Fig. 1.29): This is known as the 'Paw hand'. It is a massive hand with fat, cylindrical, spatulate fingers with blunt tips and broad and square nails.
- iv. *Eunuchoidal hand*: The hand is long and narrow and thin skinned, with delicate and tapering fingers.



Fig. 1.26: Clinodactyly—Down's syndrome



Fig. 1.27: Foot in Down's syndrome



Fig. 1.28: Simian crease



Fig. 1.29: Acromegalic hand



Fig. 1.30: Dupuytren's contracture

- v. *Marfan's syndrome*: The hand is long with tapering, spidery fingers (arachnodactyly).
- vi. *Pseudohypoparathyroidism*: Short fourth and fifth metacarpals producing a 'dimpling sign' (knuckle-knuckle-dimple-dimple sign).
- vii. *Holt-Oram syndrome*: The thumb is hypoplastic and in the same plane as the rest of the fingers. Thumb may be triphalangeal. Fifth finger may be missing. There may be radio-ulnar synostosis. The radius may be absent.
- viii. *Dupuytren's contracture* (Fig. 1.30): This occurs due to fibrositis commonly involving the ulnar side of palmar aponeurosis. This causes thickening and contraction of the aponeurosis. This initially affects the proximal and middle phalanx of the ring finger and later the little finger may be affected.

It is seen in the following conditions:

- a. Idiopathic
- b. Cirrhosis liver
- c. Phenytoin therapy
- d. People working with machines producing vibration
- e. Intake of oral contraceptive pills.

Fingers

- i. *Polydactyly* (Fig. 1.31): Supernumerary fingers
 - Causes
 - a. Congenital
 - b. Familial
 - c. Associated with VSD
 - d. Laurence-Moon-Biedl syndrome
 - e. Turner's syndrome.
- ii. *Syndactyly* (Fig. 1.32): Webbed fingers. May occur in normal individuals or in those with, certain congenital abnormalities. It is seen in Poland's syndrome (absent unilateral pectoralis major muscle with TOF).



Fig. 1.31: Polydactyly



Fig. 1.32: Syndactyly

iii. *Arachnodactyly* (Fig. 1.33): Spider fingers. These are long and thin fingers.

Causes

- Marfan's syndrome
- Hypogonadism



Fig. 1.33: Arachnodactyly



Fig. 1.34: Hypoplastic thumb—Fanconi's anaemia

- Hypopituitarism
 - Homocystinuria
 - Normal individuals.
- iv. *Absence of digits* (Fig. 1.34): Absence of one or more fingers may be congenital. Thumb may be absent in Fanconi's congenital aplastic anaemia.
- v. *Sausage fingers*: Thick and fleshy fingers seen in
- Acromegaly
 - Myxoedema
 - Psoriatic arthropathy.

Feet and Toes

Genu Varum (bow legs)

Causes

- Rickets
- Osteomalacia
- Osteitis deformans (Paget's disease)
- Achondroplasia.

Genu Valgum (knock knees)

Causes

- Congenital
- Rickets.

Large Feet

It is seen in acromegaly.

Short and Broad Feet

It is seen in achondroplasia.

“Rocker-bottom” Feet (Fig. 1.35)

This is a severe type of flat foot with a protuberant heel. Seen in Trisomy-18 (Edward’s syndrome, which may be associated with PDA).



Fig. 1.35: Rocker-bottom foot

Pes Cavus (Claw Foot) (Fig. 1.36)

Causes

- Familial
- Peroneal muscular atrophy
- Friedreich’s ataxia
- Syringomyelia
- Spina bifida occulta
- Anterior poliomyelitis.

Clawed Toes

It is seen in

- Friedreich’s ataxia
- Peroneal muscular atrophy.



Fig. 1.36: Pes cavus

Heel Pad Thickness

It is the distance measured in a X-ray film of the patient’s foot taken laterally from the lower most point of the calcaneum to the lower most point of the heel pad soft tissue shadow.

Heel pad thickness is said to be increased when

- It is more than 23 mm in males
- It is more than 21 mm in females.

**Causes of Increased Heel Pad Thickness**

- Acromegaly
- Myxoedema
- Obesity
- Peripheral oedema
- Infection or injury to heel
- Eptoin therapy.

The Skin in Clinical Medicine

The skin has three layers (Fig. 1.37). The epidermis forms the outer layer which consists of avascular epithelium. The tough fibroelastic dermis forms the middle layer which contains blood vessels, nerves, sebaceous and sweat glands and hair follicles. The hypodermis containing loose connective tissue and fat forms the inner layer.

90% of the epidermal cells are keratinocytes. They synthesise insoluble proteins, keratins. Keratins form the main component of impervious surface of the epidermis. The pigment melanin is synthesised from phenylalanine by melanocytes which are present in the basal layer of the epidermis.

The skin is the largest organ of the human body. It weighs about 4 kg and it covers an area of 2m². The brown or black colour of the skin is due to melanin. The amount of melanin present is decided by hereditary factors and the environmental factors like exposure or withdrawal from ultraviolet light.

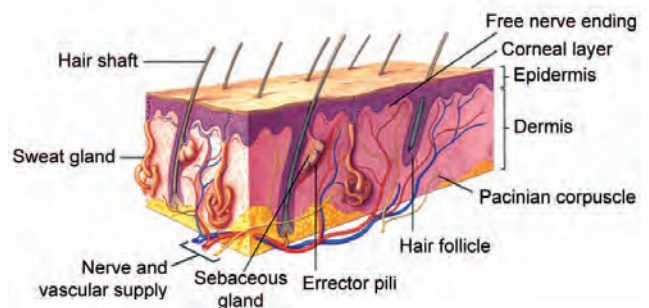

Fig. 1.37: Structure of skin

Functions of the Skin

1. *Protection*: Physical, Chemical, Infection
2. *Thermoregulation*: Blood vessels and Eccrine sweat glands
3. *Homoeostasis* of water, electrolytes and protein
4. *Lubrication and waterproofing*: Sebum secreted by sebaceous glands
5. *Sensations* – specialised nerve endings
6. *Immunological*: Lymphocytes, Macrophages, Langerhans cells
7. *Synthesis* of vitamin D by keratinocytes
8. *Body odour*: Apocrine glands
9. *Protection and prising*: Nails
10. *Calorie reserve*: Subcutaneous fat
11. *Psychosocial*: Cosmetic – skin, lips, hair, nails.

Primary Skin Lesions

Universal and symmetrical skin lesions favour the diagnosis of systemic disorder and focal asymmetrical lesions favour the diagnosis of local infection or allergy.

Terminology of Skin Lesions

Macule – Altered colour

Papule (Fig. 1.38) – Elevated skin lesion - <0.5 cm

Plaque – Palpable skin lesion - >2 cm

Nodule – Solid palpable lesion - >0.5 cm

Vesicle (Fig. 1.39) – Fluid filled blister - <0.5 cm

Bulla (Fig. 1.40) – Large fluid filled blister - >0.5 cm

Pustule – Blister filled with pus

Papilloma – Pedunculated projecting lesion

Wheal – Elevated central white lesion with red margin

Telangiectasia – Dilated small cutaneous blood vessel

Petechiae (Fig. 1.41) – Pinhead size macule of blood in the skin.



Fig. 1.39: Vesicle



Fig. 1.40: Bullae



Fig. 1.38: Papule



Fig. 1.41: Petechiae

Purpura – Larger petechiae – which do not blanch on pressure

Ecchymosis (Fig. 1.42) – Large extravasation of blood into the skin



Fig. 1.42: Ecchymosis

Haematoma – Swelling due to bleeding – collection of blood

Erythema – Redness of the skin.

Distribution and Site of Skin Lesions

Centrifugal – Smallpox, Erythema multiforme, Erythema nodosum

Centripetal – Chickenpox, Pityriasis rosea

Flexor aspect – Atopic eczema

Extensor aspect – Psoriasis

Colour of the Skin

Pallor – Anaemia, Shock (due to peripheral vasoconstriction), Haemorrhage, Intense emotion

Increased pigmentation:

Racial, Sunburn, Haemochromatosis, Chronic arsenic poisoning

Argyria, Cachexia, Addison's disease, Pigmentation of nipples and areolae in pregnancy, Pellagra, X-irradiation

Generalised loss of pigmentation – Albinism

Patchy loss of pigmentation – Vitiligo, a marker for many autoimmune disorders

Localised loss of pigmentation – Piebaldism

Erythema – Sunburn, Exanthematous fevers, Inflammatory lesions

Flushing – Drugs like nicotinic acid

Cyanosis – Central or peripheral cyanosis, Conditions simulating cyanosis-Methaemoglobinaemia

Jaundice – Yellow colouration of the skin due to increased serum bilirubin,

Conditions simulating jaundice-Carotenaemia (sparing of sclera).

Skin Lesions as Markers for Systemic Disorders

Erythema nodosum:

Sarcoidosis, Tuberculosis, Connective tissue diseases, Post-streptococcal infection, Drugs

Erythema marginatum:

Rheumatic fever

Pyoderma gangrenosum:

Ulcerative colitis, Rheumatoid arthritis

Dermatitis herpetiformis:

Gluten enteropathy

Generalised purpura:

ITP and other haematological disorders

Dermatitis artefacta:

Personality disorders-Anxiety

Nails in Clinical Medicine (Figs 1.43 and 1.44)

Koilonychia (Fig. 1.45)

It is due to thinning and softening of the nailplate resulting in spoon-shaped nail.



Causes

1. Iron deficiency anaemia
2. Haemochromatosis

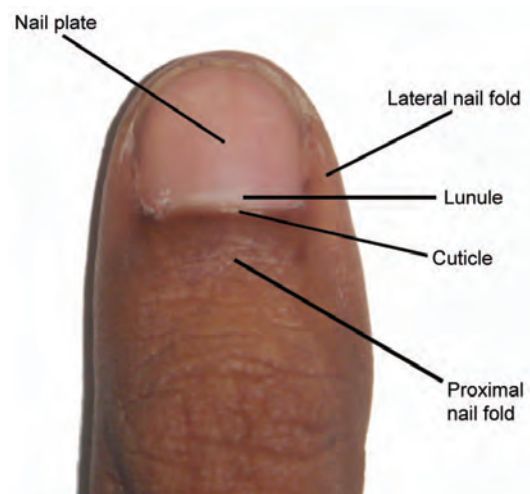

Fig. 1.43: Structure of the nail

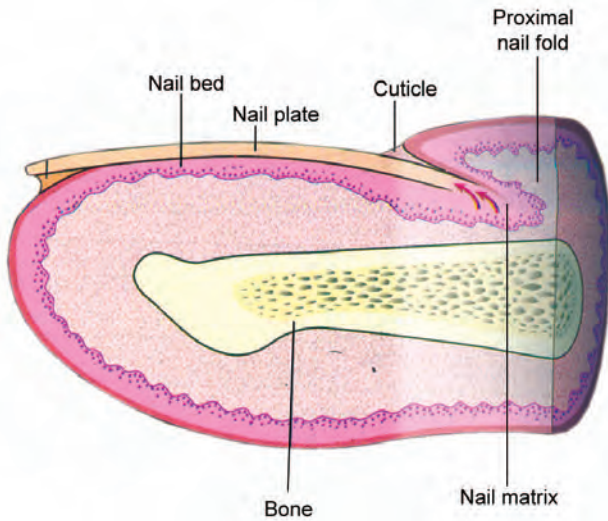

Fig. 1.44: Structure of nail (lateral view)



Fig. 1.45: Koilonychia

3. Raynaud's syndrome
4. Porphyria
5. Occupational
 - Motor mechanics
 - Rickshaw pullers
6. Ischaemic heart disease
7. Syphilis
8. Inherited—autosomal dominant.

Beau's Line (Fig. 1.46)

They are transverse ridges in the nail plate due to temporary alteration of nail growth rate.



Causes

Acute febrile illness



Fig. 1.46: Beau's line

Pneumonia
 Exanthems—Measles, Mumps
 Myocardial infarction, Pulmonary infarction
 Childbirth
 Drug reaction.

Plummer Nail

Onycholysis of the nail (rat bitten nail)



Causes

Hypothyroidism, hyperthyroidism
 Raynaud's disease
 Porphyria
 Photo-onycholysis—Doxycycline, chlortetracycline and chloramphenicol.

Lindsay Nail (Fig. 1.47)

It is characterised by proximal dull white portion and a distal pink or brown portion with a well-demarcated transverse line of separation.



Fig. 1.47: Half-half nail (Lindsay nail)



Causes

Uraemia

White Nail (Terry Nail) (Fig. 1.48)

It is characterised by white colour in the nail bed than the nail plate.



Fig. 1.48: White nail



Causes

Anaemia
Hypoalbuminaemia (cirrhosis, nephrosis)
Diabetes mellitus
CCF
Rheumatoid arthritis
Malignancy.

Red Nail

Congestive cardiac failure.

Blue Nail

Wilson's disease (Copper deposits)
Silver deposits.

Black Nail (Fig. 1.49)

Peutz-Jeghers syndrome
Cushing's syndrome
Addison's disease.

Yellow Nail Syndrome

It is characterised by yellow finger and toe nails, clubbing and onycholysis.



Fig. 1.49: Black nail



Fig. 1.50: Nail pitting in psoriasis

The other associated features are:

- Oedema of finger, ankle and face
- Infection—sinusitis, bronchitis, bronchiectasis, pleural effusion
- Carcinoma of skin, larynx, endometrium
- Lymphoma
- Agammaglobulinaemia
- Psoriasis (Fig. 1.50).

Temperature

Normal Temperature Regulation in the Body

Normally heat is being continuously produced in the body, and also is being lost continuously to the

surroundings. When the rate of heat production is equal to the rate of heat loss, the person is said to be in heat balance. But when there is a disturbance of equilibrium between the two, then the body temperature may rise leading to fever, or may fall leading to hypothermia.

Factors Determining Rate of Heat Production

- Basal metabolic rate of the body
- Muscle activity
- Effect of thyroid hormones
- Effect of epinephrine and norepinephrine.



Causes of Heat Loss from the Body

- Radiation*: Loss of heat from the body in the form of infrared rays.
- Conduction*: Heat is conducted from the body to the objects in contact with it, e.g. chair, bed, etc.
- Convection*: Heat is lost from the body by the air currents surrounding it.
- Evaporation*: Evaporation of water (sweat) from the body surface serves as an important protective mechanism in reducing body temperature which may rise due to environmental factors (hot weather). In heat stroke, sweating is impaired and so body core temperature rises to dangerous levels.

Fever

It is an elevation of body temperature above the normal circadian variation as a result of the change in the thermoregulatory centre, located in the hypothalamus.

Maximum Normal Oral Temperature

At 6.00 AM 37.0°C (98.6°F)

At 6.00 PM 37.6°C (99.6°F)

The normal diurnal variation is 1°F. The normal body temperature is more towards the evening because of increased BMR and increased skeletal muscle activity.

Rectal temperature is 0.6°C (1°F) higher than oral temperature.

Oral temperature is 0.6°C (1°F) higher than temperature recorded in the axilla.

Physiological Variation of Temperature

In a menstruating woman, the early morning temperature is subnormal in the two weeks preceding ovulation. At the time of ovulation, the temperature rises by about 0.6°C (1°F), and persists till menstruation occurs (due to thermogenic property of progesterone).

Chill is a sensation of cold that occurs in most fevers. Rigor is a profound chill with piloerection (goose flesh) associated with teeth chattering and severe shivering. Chills or rigors occur when the thermostat, situated in the hypothalamus, is suddenly reset to a higher temperature due to presence of pyrogens. The body temperature then tends to rise to the newly reset level in the thermostat by conserving heat in the body by cutaneous vasoconstriction and involuntary contraction of skeletal muscles, experienced as chills or rigors. Chills or rigors may be commonly seen with bacterial, rickettsial, protozoal, influenzal infections.

With every 1°F rise of temperature, above 100°F, the pulse rate increases by 10, the respiratory rate by 4, and BMR by 7. Oxygen consumption increases by 13%.

Fever with Relative Bradycardia

- Typhoid fever
- Meningitis
- Viral fever (Influenza)
- Brucellosis
- Leptospirosis
- Drug induced fever.

Fever with Exanthems

- Rash appearing on first day of fever—*Chicken pox*.
- Rash appearing on fourth day of fever—*Measles*.
- Rash appearing on seventh day of fever—*Typhoid*.

Febrile Convulsions

It occurs in infants and children less than 5 years old. Convulsions are common at temperatures more than 40°C. It may not be a sign of cerebral disease.

Normal	37°C to 37.6°C (98.6°F to 99.6°F)
Febrile	Above 37.8°C (100°F)
Hyperpyrexia	>41°C (>106°F)
Hypothermia	< 35°C (< 95°F)

Patterns of Fever

Continuous Fever (Fig. 1.51)

The temperature remains elevated above normal without touching the baseline and the fluctuation does not exceed 0.6°C (1°F) (diurnal variation), e.g. lobar pneumonia, infective endocarditis, enteric fever.

Remittent Fever (Fig. 1.52)

The temperature fluctuation exceeds 0.6°C (1°F), but without touching the baseline.

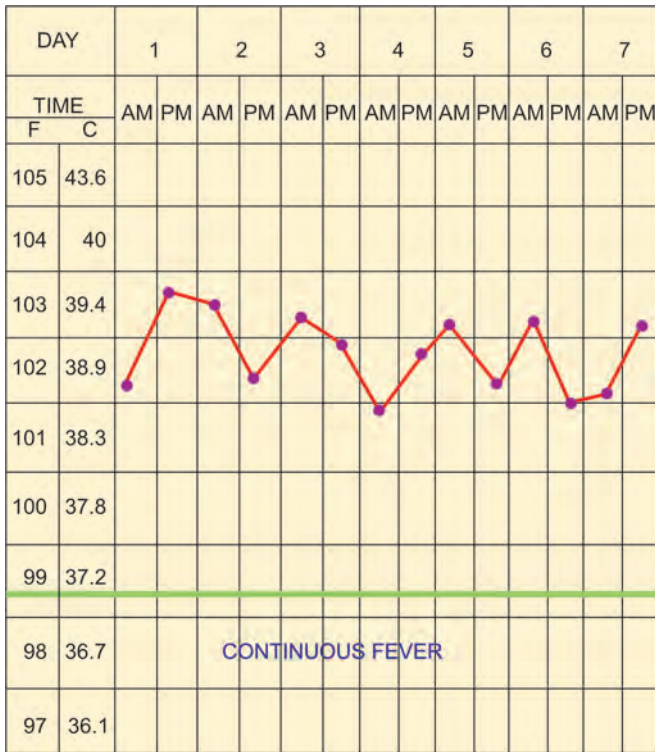

Fig. 1.51: Continuous fever

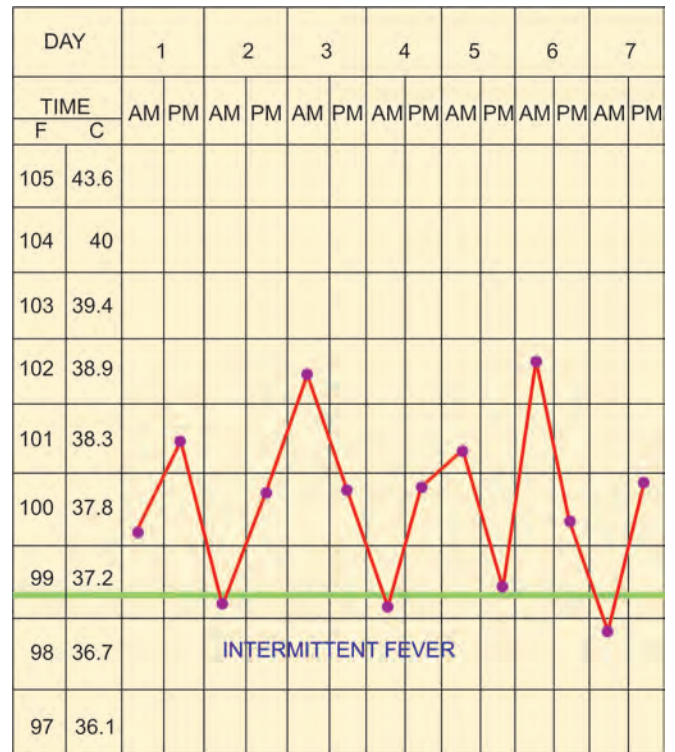

Fig. 1.53: Intermittent fever

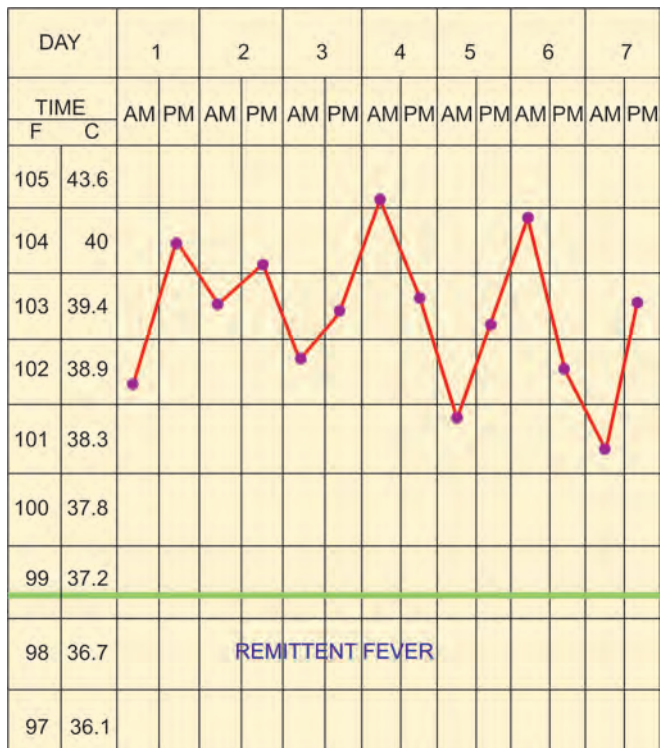

Fig. 1.52: Remittent fever

Intermittent Fever (Fig. 1.53)

The elevated temperature touches the baseline in between. In hectic or septic type of intermittent fever, the diurnal variation is extremely large, as occurs in septicaemia. *Quotidian fever* is a hectic fever occurring daily.

Relapsing Fever (Fig. 1.54)

Febrile episodes are separated by normal temperature for more than one day, e.g. *Borrelia* infection, rat bite fever.

- Tertian fever* (Fig. 1.55) occurs on the first and third day, e.g. *Plasmodium vivax*, *ovale*, *falciparum*.
- Quartan fever* (Fig. 1.56) occurs on first and fourth day, e.g. *Plasmodium malariae*.
- Pel-Ebstein fever* is a type of fever lasting for 3–10 days followed by an afebrile period of 3–10 days, e.g. Hodgkins and other lymphomas.
- Saddle back fever*: Initially fever lasts for 2–3 days followed by a remission lasting for 2 days and the fever reappears and continues for 2–3 days, e.g. Dengue fever.
- Borrelia infection and rat bite fever*: Both are associated with several days of fever followed by several days of afebrile period and then the cycle repeats.

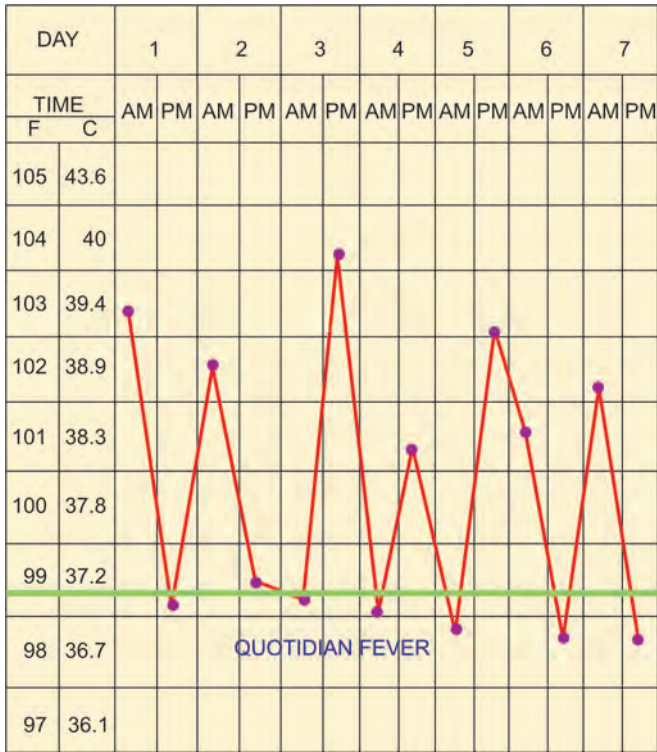

Fig. 1.54: Quotidian fever

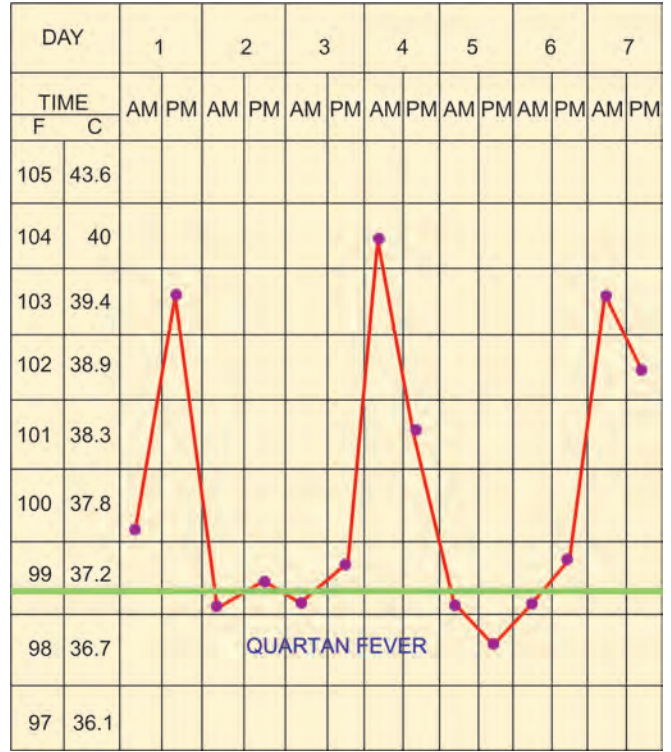

Fig. 1.56: Quartan fever

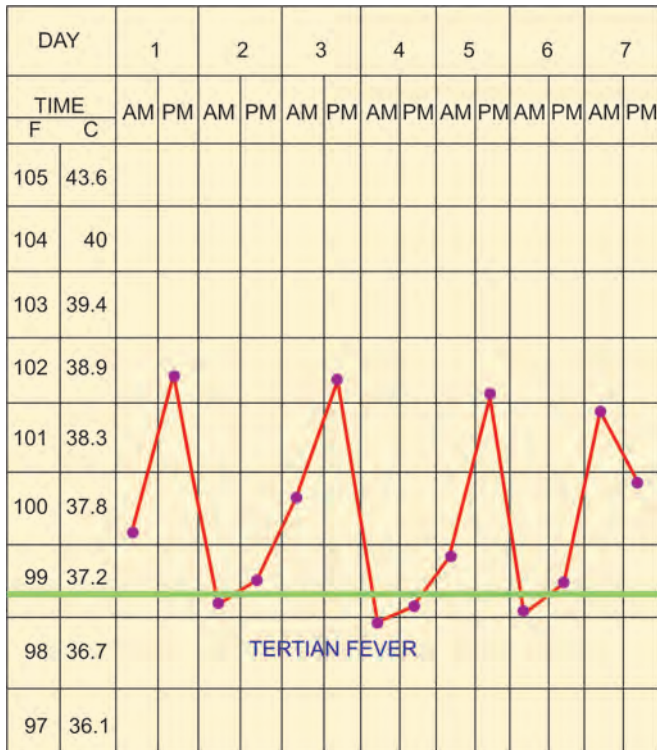

Fig. 1.55: Tertian fever

f. *Cyclic neutropenia*: Cyclic neutropenia accompanied with fever occurs every 21 days.

Drug Fever

1. It is prolonged fever and may belong to any febrile pattern
2. There is relative bradycardia and hypotension
3. Pruritus, skin rash and arthralgia may occur
4. It begins 1–3 weeks after the start of the drugs and persists 2–3 days after the drug is withdrawn
5. Eosinophilia may be present.

Almost all drugs can produce fever. Important commonly used drugs producing fever are:

- | | |
|---------------|------------------|
| Sulphonamide | Procainamide |
| Penicillins | Propylthiouracil |
| Iodides | Methyldopa |
| Anti-TB drugs | Anticonvulsants |
- Digoxin does not cause drug fever.*

Infections without Fever

1. Elderly patients
2. Newborn
3. Chronic renal failure
4. Patients on steroids

Hyperpyrexia

It is an elevation of body core temperature, above 41°C (106°F), due to inadequate dissipation of heat. It is a medical emergency, since they are prone for sudden cardiorespiratory arrest.



Causes of Hyperpyrexia

1. Pontine haemorrhage
2. Rheumatic fever
3. Meningococcal meningitis
4. Septicaemia
5. Cerebral malaria.



Treatment

It is treated with parenteral anti-pyretics to set the elevated thermostat set point to a lower level. Physical cooling aids in reducing the body temperature. Chlorpromazine is sometimes helpful in reducing the body temperature.



Causes of Hyperthermia without Elevated Resetting of Thermostat

Hyperthermia is characterised by an unchanged setting of the thermoregulatory centre with an uncontrolled increase in body temperature that exceeds body's ability to lose heat.

1. *Heat stroke*
2. *Malignant hyperthermia* is an inherent abnormality of skeletal muscle cell sarcoplasmic reticulum which is unable to store calcium ion. There is an increase in the intracellular myoplasmic calcium, leading to activation of myosin ATPase, which converts ATP to ADP + PO₄ + heat thereby producing hyperthermia.

Hyperthermia is triggered by use of inhalation anaesthetics (Halothane, Cyclopropane) and muscle relaxants (Succinylcholine).

3. *Neuroleptic malignant syndrome* is characterised by
 - a. Muscular rigidity
 - b. Autonomic dysregulation
 - c. Hyperthermia.

Neuroleptic drugs like haloperidol, phenothiazines trigger the onset of symptoms. Treatment of the above mentioned hyperthermias is by withdrawal of the offending agents. Anti-pyretics are of no use as the thermostat is not reset to higher level. Physical cooling helps. Central muscle relaxant (Dantrolene sodium) is helpful in the last two conditions. Bromocriptine is helpful in treatment of neuroleptic malignant syndrome.

4. *Drug induced*: Amphetamines, MAO inhibitors, tricyclic antidepressants, atropine
5. *Thyrotoxicosis*
6. *Pheochromocytoma*
7. *Hypothalamic fever*
8. *Serotonin syndrome*: It is seen with selective serotonin uptake inhibitors – monoamine oxidase inhibitors and other serotonergic medications. It consists of hyperthermia, diarrhoea, tremor and myoclonus.
9. *Central nervous system damage*: It is common in cerebral haemorrhage, status epilepticus, and hypothalamic injury.

Fever can Subside in the Following Ways

Crisis (Fig. 1.57): Elevated temperature settles down to the baseline immediately after starting treatment. It may be accompanied by diaphoresis, diarrhoea or diuresis, e.g. Pneumonia.

Lysis (Fig. 1.58): Elevated temperature settles down to the baseline in a step ladder fashion, after starting treatment, e.g. Typhoid fever.

Pyrexia of Unknown Origin (PUO)

It is defined as a persistent temperature of more than 101.2°F (38.4°C) lasting for more than 3 weeks, and defying one week of evaluation. (Petersdorf and Beeson). It may be classified as given below.

- a. Low grade PUO

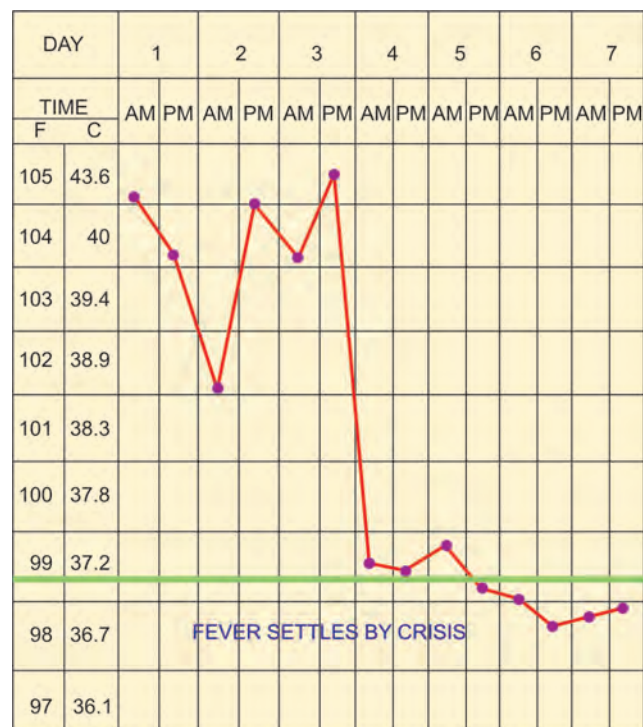

Fig. 1.57: Fever settles by crisis

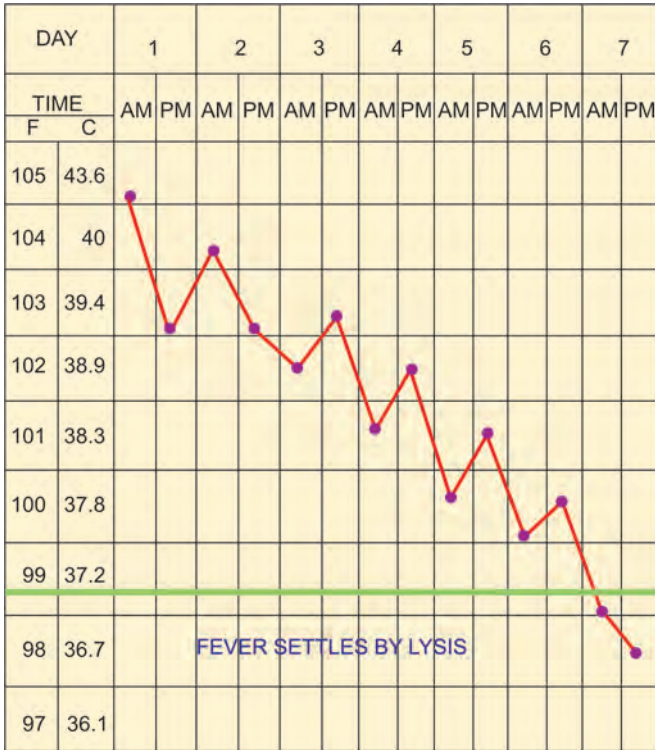

Fig. 1.58: Fever settles by lysis

- i. Exercise
 - ii. Heavy meals
 - iii. Essential hyperthermia
 - iv. Psychogenic
 - v. Excitement
 - vi. Pre-menstrual.
- b. High grade PUO
 - i. Factitious
 - ii. Fabricated
 - iii. Occupational
 - iv. Eczema
 - v. Hypothalamic lesion
 - vi. Drug
 - vii. Metabolic
 - viii. Periodic
 - ix. Ichthyosis.

Durack and Street Classification of PUO

- a. Classic PUO:

Differs from earlier definition only in duration of hospitalisation—either 3 days in hospital or 3 outpatient visits without detection of cause or 1 week of intelligent and invasive ambulatory investigations.
- b. Nosocomial PUO:

Temperature of $\geq 38.3^{\circ}\text{C}$ developing on several occasions in a hospitalised patient in whom infection

was not manifest or incubating on admission with 3 days of investigations including at least 2 days incubation of cultures.

- c. Neutropenic PUO:

Temperature of $\geq 38.3^{\circ}\text{C}$ on several occasions in a patient whose neutrophil count is less than 500/microlitre or is expected to fall in 1 to 2 days with 3 days of investigations including at least 2 days of incubation of cultures.
- d. HIV associated PUO:

Temperature of $\geq 38.3^{\circ}\text{C}$ on several occasions over a period of more than 4 weeks for outpatients or more than 3 days for inpatients with HIV, with 3 days of investigations including 2 days of incubation of cultures.



Causes of PUO

Infection	30–40%
Malignancies	20–30%
Collagen vascular disease	10–15%
Miscellaneous	10–15%

Malignancies associated with PUO

Hodgkin's disease
 NHL
 Leukaemia (Preleukaemia and aleukaemia)
 Hepatoma
 Renal cell carcinoma
 Ca colon

Important Investigations

1. *ESR-platelet correlation*: If ESR > 100 mm/hr with thrombocytosis, think of
 - a. Tuberculosis
 - b. Malignancy
 - c. Connective tissue disease.
 ESR > 100 mm/hr without thrombocytosis, think of viral infections.
2. *Elevated alkaline phosphatase*
 - a. Biliary tract infections
 - b. Alcoholic hepatitis
 - c. Primary and secondaries of liver
 - d. Hypernephroma, lymphoma
 - e. Miliary tuberculosis
 - f. CMV infection.
3. *Blood culture*
4. *Serological tests* (4 fold rise significant). Useful in:
 - a. Enteric fever
 - b. Hepatitis
 - c. CMV infection
 - d. Tularaemia

- e. Secondary syphilis
 - f. Brucellosis
 - g. Q-fever
 - h. Amoebiasis
 - i. HIV.
5. *Imaging techniques*
- a. *Plain X-ray chest*: In all patients with PUO, when initial X-ray chest is normal, a second X-ray must be taken after 3 weeks to rule out miliary tuberculosis (time taken for radiological opacity to appear). Mottling of < 0.5 mm is not detectable in X-ray.
 - b. *Contrast films*
IVP in renal abscesses, tumours
Barium meal in intrinsic bowel disease
Oral cholecystogram
Cholangiography.
 - c. *Ultrasound*: Excellent imaging is procured in thin individuals and poor imaging in obese individuals. SOL in hepatobiliary tree of more than 1 cm and endocarditic vegetation of more than 2 mm can be detected.
 - d. *CT scan*: It gives excellent imaging in obese patients also. SOL in liver of more than 1 cm and CNS lesion of more than 0.2 cm can be detected.
 - e. *MRI*: It gives best resolution of tissue planes of differing intensity. It has an advantage over CT scan when studying bone, brain, pelvis, spinal cord and thoracic large vessels. MRI is contraindicated when metal clips are present.
MRI and CT scans are useless in diagnosing meningitis.
 - f. *Radionuclide scans*: ^{99m}Tc -Sulphur colloid is used for scanning liver and spleen. ^{111}In labelled leucocytes are used for detection of intra-abdominal abscess.
6. *CSF study*
7. *Bone marrow study*

Most PUOs are due to:

1. Occult tuberculosis
2. Occult pus
3. Occult malignancies
4. Collagen vascular diseases.

90% of PUOs are diagnosed by proper evaluation. The rest recover under a watchful non-interference.

As the duration of fever increases the likelihood of infection as the cause of PUO is remote.

Extra-pulmonary tuberculosis remains the leading diagnosable cause of PUO among infections.

Therapeutic Trial

These are best avoided whenever possible. If instituted, the drug should be specific for that certain condition.

Examples include:

- Aspirin in a possible case of juvenile rheumatoid arthritis
- Antitubercular agents continued for 3 to 4 weeks in suspected occult tuberculosis
- Antibiotics in a patient with suspected endocarditis awaiting culture report
- Heparin for suspected pulmonary embolism
- Corticosteroids for suspected giant-cell arteritis
- Antitubercular or steroid therapy in a suspected case of granulomatous hepatitis.

Pain

Pain is an unpleasant sensation localised to a part of the body. Primary afferent nociceptors (pain receptors) are A-delta (small myelinated) and C (unmyelinated) fibres. Pain has to be analysed in the following way (Fig. 1.59):

1. Site
2. Character and severity
3. Duration
4. Frequency and periodicity
5. Radiation
6. Aggravating factors
7. Relieving factors
8. Associated factors.

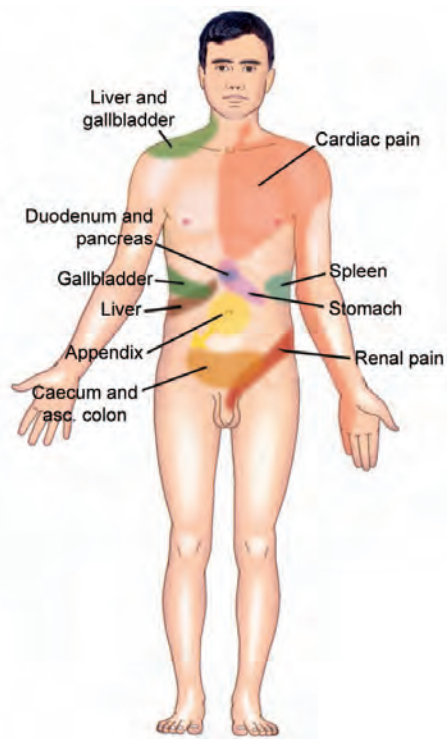

Fig. 1.59: Referred pain

Chest Pain

Chest pain may be due to any of the following conditions.

Cardiac Causes

1. Angina pectoris
2. Myocardial infarction
3. Pericarditis
4. Acute dissection of aorta.

Respiratory Causes

Pleurisy.

Chest Wall Causes

Musculoskeletal pain
Neuropathic pain.

GI Causes

1. Reflux oesophagitis
2. Hiatus hernia
3. Oesophageal spasm.

Angina Pectoris

It is a midline retrosternal constrictive, compressive or squeezing diffuse pain lasting for 3-15 minutes. It may radiate to either arm, either shoulder, jaw, back and upper abdomen. It is aggravated by exertion, heavy meal, emotion and is relieved by rest or nitrates. Usually the patient lies still.

When there are no risk factors for ischaemic heart disease, precordial pain in a young individual or a fertile female is mostly non-ischaemic.

Myocardial Infarction (MI)

Pain in MI is a similar anginal pain of spontaneous origin lasting for more than 30 minutes, but the intensity is very severe. In contrast to angina, this pain is not rapidly relieved by rest or coronary dilator drugs. It may be accompanied by autonomic disturbances like diaphoresis, nausea, hypotension and a feeling to defaecate. Patient is usually restless.

Pericardial Pain

It is a steady, substernal discomfort that mimics the pain of MI; it is worsened by lying down and is relieved by sitting and leaning forward. Often pain may be pleuritic, consequent to accompanying pleural inflammation.

Pain in Acute Aortic Dissection

The pain is of abrupt onset, reaches a peak rapidly and is felt in the centre of the chest and/or the back depending on the site of aneurysm. This pain lasts for many hours and is not aggravated by changes in position or respiration. It is associated with unequal or absent pulses.

Pleural Pain

It is a sharp, knife like, localised superficial pain, aggravated by deep inspiration and coughing due to stretching of the inflamed parietal pleura and is relieved by lying down on the affected side due to restricted movement of chest on the same side.

In diaphragmatic pleurisy, pain arising from central tendinous portion of the diaphragm is felt characteristically at the tip of the shoulder, trapezius ridge and the neck since the central part of diaphragm receives sensory supply from phrenic nerve (C3, 4, 5). Pain may radiate down to upper abdomen when peripheral part of diaphragmatic pleura (supplied by 6th to 12th intercostal nerves) is involved simulating acute abdomen.

Musculoskeletal Pain

Costo-chondral and chondro-sternal articulations are most common sites of anterior chest pain. Pain may be darting and lasts for a few seconds or it may be a dull ache enduring for hours or days.

Tietze's Syndrome

Painful swelling of one or more costo-chondral articulations, usually second or third.

Neuropathic Pains

Neuropathic pains have an unusual burning, tingling or electric shock like quality. Pain is triggered by very light touch and on examination, sensory deficit is characteristically present in the corresponding dermatome, e.g. damage to peripheral nerves as in diabetic polyneuropathy or peripheral afferents as in herpes zoster.

Abdominal Pain

Some important causes:

1. Inflammation of peritoneum
2. Mechanical obstruction to hollow viscera
3. Vascular disturbances
4. Abdominal wall causes (trauma or infection of muscles)

Causes of Acute Chest Pain

Disorder	Quality	Duration	Site of pain	Associated features
Angina	Compressing Squeezing	> 2 and <10 min	Retrosternal and Classical radiation	Precipitated by exertion/ emotional stress/exposure to cold
Unstable angina	Similar to angina	10-20 min	Similar to angina	Similar to angina but with less exertion or even at rest
Acute myocardial infarction	Similar to angina but very severe	Variable but > 30 min	Similar to angina	Unrelieved by nitrates Associated cardiac failure/ arrhythmia
Aortic stenosis	Similar to angina	Recurrent episodes	Similar to angina	Late-peaking ESM with conduction to carotid arteries
Aortic dissection	Knife like tearing	Unrelenting pain- onset abrupt	Radiating to back between shoulder blades	Connective tissue disorder/ HTN/loss of peripheral pulse
Pericarditis	Sharp	Episodic or hours/days	Retrosternal	Relieved by sitting or leaning forward pericardial rub
Pulmonary embolism	Pleuritic	Abrupt Minutes to hours	Similar to angina or lateral	Tachycardia, dyspnoea, hypotension
Pulmonary hypertension	Variable	Compressing	Substernal	Raised JVP, oedema, dyspnoea, loud P ₂
Pneumonia/pleurisy	Pleuritic	Variable	Localised unilateral	Pleural rub, cough, crackles, dyspnoea
Pneumothorax	Pleuritic	Sudden onset-hours	Unilateral localised	Hyper-resonant note, decreased breath sounds, coin sound
GERD	Burning	10-60 min	Substernal epigastric	Post-prandial pain More on recumbency
Oesophageal spasm	Compressing or burning	2-20 min	Retrosternal	Simulates angina
Peptic ulcer	Burning	Prolonged	Epigastric	Relieved with food, antacids, H ₂ blockers, PP inhibitors
Gallbladder disorders	Compressing	Prolonged	Right hypochondrium	Pain follows food
Herpes zoster	Sharp/burning	Variable	Dermatomal distribution	Vesicular lesions over the affected segment
Musculoskeletal	Variable	Aching	Localised	Local tenderness, pain on movement
Psychological	Variable	Variable	Variable	Anxiety/depression

5. Distention of visceral surfaces (hepatic or renal capsules)
6. Referred pain from extra-abdominal sources (pneumonia, IHD, spine, genitalia)
7. Metabolic causes (DKA, porphyria, uraemia, etc.)
8. Neurogenic causes.

Pain due to Disorders of GIT

Oesophageal Pain

This may be either due to oesophageal spasm or due to reflux oesophagitis. In case of oesophageal spasm, the pain is retrosternal and mimics anginal pain. In case of reflux oesophagitis, the pain is retrosternal and has a burning character, usually occurring about 1 hour after a meal.

Peptic Ulcer Pain

Duodenal ulcer: It is often an episodic, recurrent epigastric pain described as sharp, burning or ill-defined. It characteristically occurs from 90 minutes to 3 hours after eating and awakens the patient from sleep. Pain is relieved by food, antacids or H₂ blockers.

Changes in character of pain suggests development of complications.

Pain radiating to back	Penetration of ulcer
Pain aggravated by food and accompanied by vomiting	Gastric outlet obstruction
Abrupt, severe abdominal pain	Perforation of ulcer
When accompanied by coffee ground vomitus and melena	Ulcer bleed

Some patients with duodenal ulcer have no symptoms.

Gastric ulcer: Epigastric pain, which is worsened by taking food and is relieved by vomiting. Relief with antacids is less consistent than that of duodenal ulcer pain.

Mechanical Small Bowel Obstruction

In this condition, the colicky pain is mid abdominal which tends to be more severe in case of high obstruction. Pain occurs in paroxysms and the patient is comfortable in between the pains. Borborygmi is heard during episodes of pain. Later, pain becomes less severe as the motility is impaired in the oedematous intestine.

If there is strangulation of gut, pain is steady, severe, localised, without colicky nature. Pain of small bowel obstruction is accompanied by faeculent vomiting, singultus and obstipation (No passage of faeces or gas).

Colonic Obstruction

Colicky abdominal pain is of much less intensity, felt at any site over abdomen depending on the part of colon involved, e.g. hypogastric pain in sigmoid colonic involvement. Faeculent vomiting is rare; Constipation progresses to obstipation.

Pain in Acute Appendicitis

In the initial stages, pain is poorly localised in the periumbilical or epigastric region. As inflammation spreads, pain becomes somatic, more severe and is localised to right lower quadrant. Pain is accompanied by anorexia, nausea, vomiting and fever. Tenderness at McBurney's point (junction of medial 2/3 and lateral 1/3 of spinoumbilical line) is elicited later.

Acute Pancreatitis

In acute pancreatitis, there is a severe, constant epigastric pain radiating to the back, lasting for 24 hours. Pain is aggravated by taking alcohol or fatty food and is relieved by sitting upright. Pain may be associated with vomiting, jaundice, paralytic ileus, gallstones, and shock. There is profound elevation of amylase levels.

Biliary Colic

Acute distention of gallbladder causes pain in the right hypochondrium with radiation to the right, posterior region of thorax or to the tip of right scapula.

Distention of common bile duct (CBD) causes pain in the epigastrium radiating to upper part of lumbar region.

Murphy's sign: In acute cholecystitis, the patient is asked to breathe in deeply and gallbladder is palpated in the usual way. At the height of inspiration, the breath is arrested with a gasp as the mass is felt.

Pain of Peritonitis

It is a steady and aching pain located directly over inflamed area. The pain is accentuated by pressure or changes in tension of the peritoneum and hence the patient lies still. There is associated tonic muscle spasm. The intensity of pain is dependent on the type and amount of foreign substance to which the peritoneal surfaces are exposed.

If the peritonitis is due to perforation of a hollow abdominal viscera, liver dullness is obliterated.

Superior Mesenteric Artery Occlusion

It is a mild, continuous, diffuse pain present for 2 to 3 days before vascular collapse or peritonitis sets in. There is no tenderness or rigidity. Bloody diarrhoea may be present.

In chronic mesenteric artery insufficiency, abdominal pain occurs after intake of food (abdominal angina).

Pain Referred to Abdomen

Possibility of intrathoracic disease must be considered in every patient with abdominal pain. Apparent abdominal muscle spasm caused by referred pain will diminish during inspiration whereas it is persistent throughout respiratory phases, if it is of abdominal origin.

Pain of diaphragmatic pleuritis is felt at right upper quadrant of abdomen.

Referred pain from spine is characteristically intensified by certain motions like coughing, sneezing or straining and is associated with hyperaesthesia over involved dermatomes.

Pain referred from testicles or seminal vesicles is accentuated by slightest pressure on either of these organs. The abdominal discomfort is of dull aching character and is poorly localised.

Abdominal Wall Pain

It is a constant, aching pain, aggravated by movement, prolonged standing and pressure. When muscles of other parts of the body are also involved, myositis should be considered.

Metabolic Causes of Abdominal Pain

Whenever the cause of abdominal pain is obscure, one of the following metabolic causes must be considered.

1. Diabetic ketoacidosis
2. Porphyria
3. Uraemia
4. Lead colic
5. Hyperlipidaemia
6. C1 esterase deficiency.

Neurogenic Abdominal Pain

Causalgic pain is of burning character and is limited to the distribution of peripheral nerve. Normal stimuli like touch can evoke this type of pain. There is no muscle spasm or change with respiration or food intake.

Pain from spinal nerves or roots is of lancinating type. It may be caused by herpes zoster, arthritis, tumours, herniated nucleus pulposus, diabetes, syphilis. Pain is aggravated by movement of spine and is usually confined to a few dermatomes. Hyperaesthesia is common.

Psychogenic Abdominal Pain

There is no relation to meals. Onset is usually at nights. There is no nausea or vomiting. There is no abdominal muscle spasm; even if present does not persist. There is no change with respiration. But restriction of depth of respiration occurs as a part of anxiety state.

Renal Pain

Pain due to obstruction of urinary bladder causes a dull suprapubic pain of low intensity.

Pain due to ureteric obstruction (intravesical portion) is characterised by severe suprapubic and flank pain which radiates to genitalia and upper part of thigh.

Obstruction of ureteropelvic junction causes pain at costovertebral angle, whereas obstruction of the remainder of the ureter is associated with flank pain which radiates from loin to groin.

Peripheral Vascular Pain

Arterial Occlusion

Intermittent Claudication

Patient often complains that after walking a distance (claudication distance), the pain starts and on continued walking the pain is aggravated and compels the patient to take rest. Pain disappears when the exercise stops.

Rest Pain

This pain is continuous and aching in nature. This is due to ischaemic changes in the somatic nerves (cry of the dying nerves).

Venous Pain

Venous pain may be due to:

Varicose Veins

Pain felt in lower leg or whole of the leg according to the site of varicosities. Pain gets worse when the patient stands up for a long time and is relieved when he lies down. Pain of varicocele of testes is of similar character.

Venous Thrombosis

Patient may have pain and swelling of leg (around ankle).

Homan's sign: Dorsiflexion of foot elicits pain in the calf.

Moses's sign: Squeezing of calf muscle from side to side elicits pain.

In superficial thrombophlebitis, there is pain and tenderness over superficial inflamed veins.

The above manoeuvres may dislodge the thrombus resulting in pulmonary embolism.

Neurogenic Claudication

Symptoms of dysfunction of cauda equina appear on walking or prolonged standing and are relieved by rest. This is due to lumbar canal stenosis which is made worse in middle age due to degenerative changes especially between L₄ and L₅ vertebrae.

There is march of pain with paraesthesia and absent ankle jerk after exercise. Symptoms take 5–10 minutes to fade.

Oedema

Oedema is a collection of excess fluid in the body interstitium, from the intravascular compartment.

Ascites Pathological collection of fluid in the peritoneal cavity

Hydrothorax Pathological collection of fluid in the pleural cavity

Normal Body Fluid Compartments

Compartment	Volume (in litres)	Percentage lean body weight
1. Total body water	42	60
2. Extracellular water	14	20
- Plasma	3–4	4–5
- Interstitial	11	16
3. Intracellular water	28	40

Anasarca Generalised oedema
Pericardial effusion Pathological collection of fluid in
the pericardial cavity.

Aetiology and Types of Oedema

Generalised Oedema

1. Cardiac oedema
2. Renal oedema
3. Hepatic oedema
4. Nutritional oedema
5. Cyclic-premenstrual
6. Idiopathic.

Localised Oedema

1. Venous oedema
2. Lymphatic oedema
3. Inflammatory oedema
4. Allergic.

Fast Oedema

This indicates oedema occurring in conditions causing hypoalbuminaemia. The oedema pits on pressure application but disappears within 40 seconds of its application.

Slow Oedema (Fig. 1.60)

This indicates oedema occurring in conditions causing congestion (CCF). The oedema pits on pressure application but lasts for more than 1 minute.

Pathophysiology of Oedema (Fig. 1.61)

Normal hydrostatic pressure at the arteriolar end of the capillary bed = 35 mm Hg.



Fig. 1.60: Pitting pedal oedema

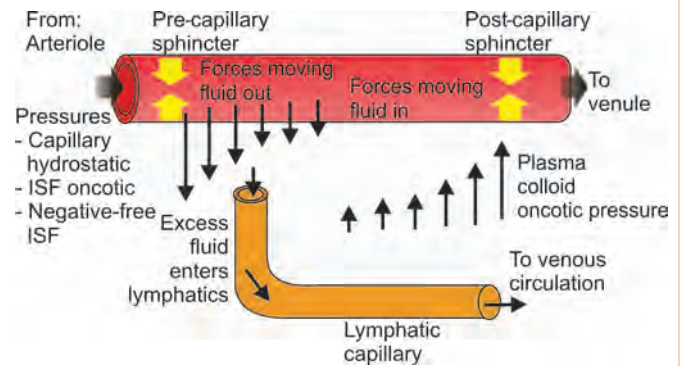

Fig. 1.61: Pathophysiology of oedema

Normal hydrostatic pressure at the venular end of the capillary bed = 12-15 mm Hg.

Oncotic pressure of plasma = 20-25 mm Hg.

Normally, fluid volume in different compartments of the body is maintained by the normal Starling's forces, mentioned above.

1. Hydrostatic pressure at the arteriolar end of the capillary tends to push the intravascular fluid into the interstitium.
2. The oncotic pressure at the venous end of the capillary, maintained chiefly by body albumin, tends to remove fluid from the interstitium into the vascular compartment.

The normal lymphatic flow carries the albumin, extruded from the intravascular compartment into the interstitium, back into the intravascular compartment, to maintain the normal oncotic pressure.

Oedema may result when there is:

1. Increase in hydrostatic pressure
2. Decrease in oncotic pressure
3. Obstruction to veins/lymphatic flow
4. Vascular wall injury (mechanical, thermal, chemical).

Characteristic Features of Oedema of Various Aetiologies

Cardiac Oedema

The pathophysiology of this oedema is:

- a. Increased back pressure on the venous side of circulation leading to transudation of fluid into the interstitium.
- b. Decreased intravascular volume leading to decreased renal blood flow and thereby stimulation of the renin-angiotensin mechanism.
- c. Decreased intravascular volume leads to hyperosmolality of the blood, which in turn stimulates the

osmoreceptors in the posterior pituitary to secrete antidiuretic hormone. This hormone stimulates the thirst mechanism and the patient consumes more water, which contributes to the oedema formation.

- d. In left sided cardiac failure there is accumulation of fluid in the lung interstitium leading to development of pulmonary oedema.

Cardiac oedema is a dependent oedema found over the ankles in ambulant patients, and over the sacrum in bed ridden patients.

Renal Oedema

The pathophysiology of this oedema is:

- Primary increase in sodium and water retention by the kidneys (as in AGN).
- Decrease in oncotic pressure due to increased loss of albumin in urine (as in nephrotic syndrome)
- However, in CRF, oedema need not be present initially. In the last stage of CRF, oedema develops due to retention of sodium and water.

Renal oedema characteristically involves the loose connective tissues, especially over the periorbital region, more prominent when the patient wakes up in the early morning, as the patient with renal oedema are able to lie down flat (comfortably).

Oedema Seen in Liver Disease

The pathophysiology of this oedema is that the collection of fluid occurs characteristically first in the peritoneal cavity (Ascites), because of the following:

- Increased portal venous pressure (Portal HTN).
- Obliteration of the lymphatic drainage of the liver.
- Hypoalbuminaemia (Due to impaired synthesis of albumin by the decompensated liver).
- Decrease in the intravascular volume leading to activation of renin-angiotensin-aldosterone mechanism and retention of salt and water. Decreased metabolism of aldosterone by the decompensated liver leads to secondary hyperaldosteronism and increased retention of salt and water.
- Tense ascites leads to increased intra-abdominal pressure thereby decreasing venous return from the lower limbs and hence development of pedal oedema.

Oedema of Nutritional Origin

It is a generalised oedema. Causes of nutritional oedema are:

- Decreased ingestion of proteins leading to hypoalbuminaemia and therefore oedema.
- Thiamine deficiency leading to beriberi. Oedema in beriberi occurs because of the following:

- Due to lack of thiamine, glucose is incompletely metabolised and lactic and pyruvic acids accumulate, which causes peripheral vasodilatation and transudation of fluid through the capillaries.
 - The resulting anaemia also contributes to the development of oedema.
 - Development of high output cardiac failure results in oedema.
- iii. Oedema can occur on refeeding after prolonged starvation due to:
- Increased salt intake.
 - Increased release of insulin which acts directly on the renal tubules to increase sodium re-absorption.

Idiopathic Oedema

Periodic episodes of oedema occurring exclusively in women. Diurnal variation of weight occurs with orthostatic retention of salt and water. This suggests an increase in capillary permeability on erect posture.

Cyclical or Pre-menstrual Oedema

This oedema is due to sodium and water retention, secondary to excessive oestrogen stimulation.

Other Causes of Oedema

- Myxooedema (oedema typically located in pre-tibial region along with periorbital puffiness)
- Pregnancy.

Less Common Causes of Facial Oedema

- Myxooedema
- Allergic reaction
- Trichinosis.

Localised Oedema

- Venous oedema*
 - Deep vein thrombosis
 - Thrombophlebitis
 - Varicose veins
 - SVC/IVC obstruction.
- Lymphatic oedema*
 - Chronic lymphangitis
 - Resection of regional lymph nodes
 - Filariasis
 - Radiotherapy
 - Congenital (Milroy's disease—congenital absence of lymphatic tissue).
- Inflammatory/allergic causes*
 - Cellulitis
 - Bee/wasp sting.

Drugs Causing Oedema

1. Non-steroidal anti-inflammatory drugs
2. Arteriolar vasodilators
 - Minoxidil
 - Hydralazine
 - Clonidine
 - Alpha-methyl dopa
 - Guanethedine
3. Calcium channel blockers
4. Alpha-blockers
5. Cyclosporin
6. Growth hormone
7. Steroidal hormones
 - Glucocorticoids
 - Anabolic steroids
 - Oestrogens
 - Progestins
8. Immunotherapy
 - Interleukin-2
 - Monoclonal antibody
 - OKT-3

Shock

Shock may be defined as a state in which there is profound and widespread reduction in the effective delivery of oxygen and other nutrients to tissues leading to reversible, and if prolonged, to irreversible cellular injury.

Acute circulatory failure, shock, low cardiac output states are various terms used to describe a clinical syndrome of hypotension, peripheral vasoconstriction, oliguria and often impaired consciousness.

Control of Arterial Blood Pressure

Organ perfusion is dependent on an appropriate perfusion pressure which is determined by cardiac output and systemic vascular resistance. Cardiac output in turn is a product of stroke volume and heart rate. Stroke volume depends upon preload, afterload and myocardial contractility.

Control Mechanism

1. Release of vasodilator metabolites (adenosine)
2. Release from endothelium of substances which relax (EDRF or nitric oxide) vascular smooth muscle
3. Release from endothelium of substances which contract (endothelin) vascular smooth muscle
4. Autonomic nervous system (baroreceptor reflexes and vasomotor centre in the brainstem)
5. Release of vasopressin

6. Renin angiotensin aldosterone system
7. Release of vasodilators (prostaglandins and kinins)
8. Fluid and electrolyte balance.

Classification

Cardiogenic Shock

Myopathic

- a. Acute MI
- b. Dilated cardiomyopathy
- c. Myocardial depression in septic shock
- d. Myocarditis.

Mechanical

MR, VSD following MI

Ventricular aneurysm

LV outflow obstruction (AS, HOCM).

Electrical

Arrhythmias

- Tachyarrhythmias (SVT, VT, VF)
- Bradyarrhythmias (complete heart block—Stokes-Adams attacks)
- Tachybradyarrhythmias (Sick sinus syndrome).

Extracardiac Obstructive Shock

Pericardial tamponade

Constrictive pericarditis

Acute massive pulmonary embolism

Severe pulmonary hypertension

Coarctation of the aorta.

Oligemic Shock

Fluid depletion (vomiting, diarrhoea, burns, sweating, fistulae, pancreatitis)

Haemorrhage

- a. Internal: GIT perforation, splenic rupture, ectopic pregnancy
- b. External: Trauma, fracture femur, etc.

Distributive Shock

Septic shock

Toxins

Anaphylaxis

Neurogenic shock

Endocrinologic shock.

Hypovolemic Shock

Because of decreased blood volume, there is inadequate ventricular filling, decreased preload and stroke volume.

Classification of Shock

Type of shock	Filling pressures	Cardiac output	Sys. vascular resistance	PCWP	Aetiologies
Cardiogenic	↑	↓	↑	↑↑ ↑ or N ↓ or N	MI, cardiomyopathy, valvular heart disease, arrhythmias, acute VSD, MR RV infarct
Distributive (septic)	↓	↑	↓	↓	Sepsis, anaphylaxis, toxic shock syndrome
Hypovolemic	↓	↑↓	↑	↓	Haemorrhage, hypovolemia
Obstructive	↑ (Proximal) ↓ (Distal)	↓	↑	↑	Pulmonary embolism tamponade, tension pneumothorax

Cardiogenic Shock

Systolic arterial pressure is < 80 mm Hg and cardiac index is < 1.8 L/min/m². LV filling pressure is elevated.



Common Causes

MI (> 40% of LV involvement), myocarditis, following cardiac arrest or prolonged cardiac surgery.



Cardiac Causes of Acute Circulatory Failure

Endocardial	Mitral valve disease Aortic valve disease
Myocardial	RV infarct LV infarct Cardiomyopathy Myocarditis Atrial arrhythmias
Pericardial	Tamponade Constrictive pericarditis
Great vessels	Aortic dissection Pulmonary embolism.

Extracardiac Obstructive Shock

There is inability of the ventricles to fill during diastole, markedly limiting stroke volume and ultimately the cardiac output.

Distributive Shock

There is profound decrease in peripheral vascular resistance by the release of histamine, kinins, prostaglandins, lipid A, endorphins, TNF, IL-1 and IL-2. Some prostaglandins and leukotrienes produce vasoconstriction.

Patient may suffer from more than one form of shock simultaneously.



Clinical Features

Patients have hypotension (mean arterial BP < 60 mm Hg, systolic BP < 100 mm Hg), tachycardia (> 120/min), oliguria (< 30 ml/hr), altered sensorium, cold clammy extremities (not a characteristic of distributive shock).

Patients also have manifestations specific to the type of shock.



Investigations

- Complete blood count
- Serum electrolytes
- Serum creatinine
- Coagulation studies
- Blood grouping and typing
- ABG
- Examination of the stool and nasogastric contents for blood
- Culture of appropriate body fluids
- Chest X-ray
- ECG
- Right heart catheterisation (gives clue as to the type of shock)
- Ventilation-perfusion lung scan
- Echocardiogram
- Endocrine studies.



Management

Shock is an emergency necessitating IMCU management.

Goals

1. To keep mean arterial pressure > 60 mm Hg or systolic BP > 100 mm Hg.

2. To maintain blood flow to organs which are vulnerable (kidneys, liver, brain and lungs).
3. To maintain arterial blood lactate < 22 mmol/L.



Treatment

1. Maintenance of airway and ventilation is essential.
2. Volume resuscitation should be done in all cases except in cardiogenic shock.
 - a. The pneumatic antishock garment (PASG) with sequential inflation of legs and abdominal compartments to 15–40 mm Hg may be useful in all types of shock except cardiogenic shock. It helps by increasing peripheral vascular resistance.
 - b. Trendelenburg's position to aid venous return and cardiac index.
 - c. Fluid resuscitation by giving 500 ml bolus of normal saline with further infusions depending on BP and other parameters. Fresh frozen plasma or packed cells may be needed.
3. Vasopressors
 - i. Dopamine is the pressor of first choice except in cyclic anti-depressant and phenothiazine overdoses (5 µg/kg/min if renal perfusion is impaired or 10 µg/kg/min when renal perfusion is adequate).
 - ii. Norepinephrine given in a dose of 2–8 µg/minute causes peripheral vasoconstriction and lesser chronotropic and inotropic response.
 - iii. Dobutamine can be given in a dose of 1–10 µg/kg/minute to increase cardiac output in a low cardiac output state.
 - iv. Amrinone can be given by adding 500 mg to 150 ml of normal saline for a final volume of 250 ml. A loading dose of 0.75 mg/kg is given over 2–3 minutes, with infusion following at 5–10 µg/kg/minute.
 - v. Isoproterenol in a dose of 1–4 µg/minute can be tried only in atropine unresponsive bradycardia requiring pacemaker.
4. Sodium bicarbonate should be given when pH falls less than 7.2. Inappropriate bicarbonate use may cause CNS acidosis and diminish peripheral tissue oxygenation.
5. Antibiotics should be given empirically when sepsis is suspected, and glucocorticoids when adrenal insufficiency is suspected (after drawing blood for basal cortisol).

Cardiogenic Shock

1. Oxygen
2. Nitrates
3. Intra-aortic balloon counter pulsation for salvaging reversibly damaged myocardium
4. Thrombolytic therapy or CABG or PTCA to restore myocardial perfusion
5. Vasopressors like dopamine or dobutamine or both.

Cardiac Tamponade

1. Inotropic agents (norepinephrine, dopamine)
2. Pericardiocentesis.

Septic Shock

- a. Infection must be treated (antimicrobials, surgical drainage of pus or both)
- b. CVS monitoring and support
- c. Interruption of pathogenic sequence by
 - i. Inhibition of endorphin receptors with naloxone
 - ii. Inhibition of arachidonic acid metabolites
 - iii. Human monoclonal antibody against lipid A, inhibitors of sepsis mediators like IL-1 and TNF-α.

Anaphylactic Shock

1. Maintenance of airway.
2. Epinephrine is the cornerstone of therapy. It is given in a dose of 0.3–0.5 mg (0.3–0.5 ml of 1:1,000 solution) SC and repeated twice at 20 minute intervals if necessary.

It can be given intravenously (3–5 ml of 1:10,000 solution) or sublingually (0.5 ml of 1:1,000 solution) or via endotracheal tube (3–5 ml of 1:10,000 solution).
3. Volume expansion by crystalloid or colloid.
4. Inhaled beta-agonists to treat bronchospasm.
5. Aminophylline is used as a second line drug.
6. General measures to delay the absorption of the offending antigen. For orally ingested antigens, activated charcoal (50–100 g) with 1–2 g/kg (maximum 150 g) of sorbitol or 300 ml of magnesium citrate can be given. Emesis is not indicated.

For injected antigens, slight constriction and local epinephrine injection at the affected site may be useful.
7. Antihistamines may shorten the duration of the reaction. For recurrent symptoms, H₂ blockers may be useful.
8. Glucocorticoids (Hydrocortisone 100 mg IV every 6 hours) have no effect for 6–12 hours, but they

may prevent recurrence or relapse of severe reactions.

9. Glucagon in a dose of 1 mg bolus followed by a drip of 1 mg/hour provides direct inotropic support for patients taking beta blockers.
10. Patients should be readmitted when there is relapse.
11. Patients requiring radiocontrast administration despite a previous reaction should receive prednisone, 50 mg PO q6h for 3–4 doses and diphenhydramine, 50 mg PO 1 hour before the procedure. Cardiac resuscitative measures should be available.

Fundamentals in Genetics

Introduction

Chromosomes are the carriers of inherent factors. They are situated in the nucleus of the cell. They are made up of double stranded Deoxyribonucleic acid (DNA).

DNA are found only in the chromosomes and are double stranded helical structures, bound together by hydrogen bonds. It is made up of nucleic acid, a complex substance composed of long chains of molecules called nucleotides. Each nucleotide is composed of:

- a. Nitrogenous bases

Purines	Adenine (A) & Guanine (G)
Pyrimidines	Cytosine (C) & Thymine (T)

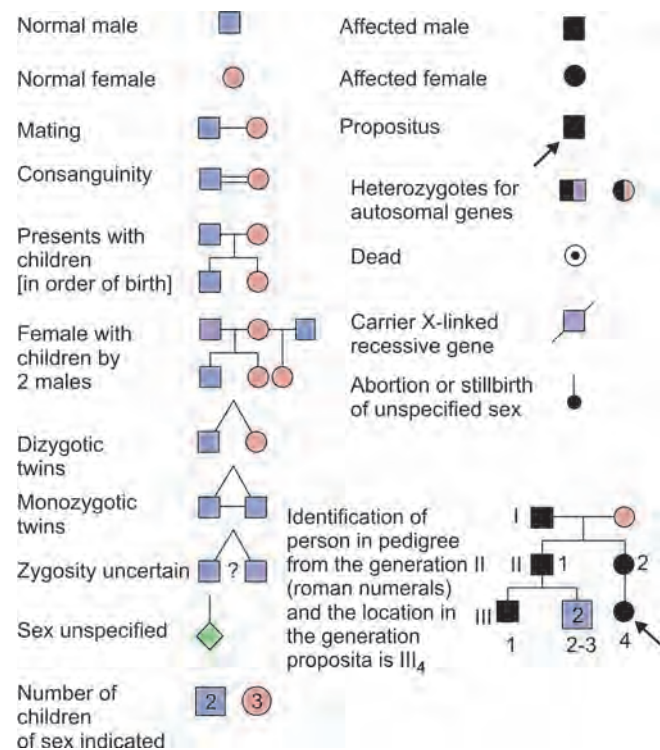

Fig. 1.62: Symbols used in pedigree chart

- b. Sugar moiety Deoxyribose
- c. Phosphate molecule.

Genes are made up of DNA. The function of the genes is to provide exact information for synthesis of specific amino acid sequence of the protein they control. The genetic code for this information is founded on triplet codons (the sequential nitrogenous bases for specific amino acids).

Ribonucleic acid or RNA are mainly found in the nucleolus and cytoplasm. They contain uracil instead of thymine as pyrimidine base, pairing with adenine. The sugar moiety is ribose and they are single stranded. They form a conduit in the formation of the polypeptide chain, as coded by the gene for the specific protein.

Normal Chromosome Number and Structure

There are 22 pairs of autosomes and 1 pair of sex chromosomes (XX in females and XY in males).

The arrangement of chromosomes in pairs in decreasing order of size, and numbered from 1 to 22 is known as *Karyotyping of chromosomes*. It represents the chromosomal constitution of a person.

The chromosomes are divided into 7 groups, from A to G depending upon their size and position of the centromere (nipped-in narrow portion, where the chromatids meet) of the chromosome.

Metacentric chromosome: The centromere is in the centre.

Acrocentric chromosome: The centromere is close to one end.

Submetacentric chromosome: The centromere is in intermediate position.

Each chromosome has a short arm called 'p' (petit) and a long arm called 'q'. These arms are divided into regions, bands and sub-bands, numerically, e.g. 7q 21.2 means long arm of chromosome 7, region 2, band 1 and sub-band 2.

The normal male has 46 XY chromosomal constitution.

The normal female has 46 XX chromosomal constitution.

Turner's syndrome: When a sex chromosome has been lost it may result in chromosomal constitution of 45 XO.

Klinefelter's syndrome: When a sex chromosome has been added it may result in chromosomal constitution of 47 XXY.

When a chromosome is added or deleted, a (+) or (-) sign is incorporated.

Example: Down's syndrome, in which an extra chromosome is added on chromosome 21, is indicated as 47, XY, +21.

If part of short arm is missing on chromosome 5, it is indicated as 46, XY, 5p- (Cri-du-chat syndrome).

Chromosomal Abnormalities

These can be divided into those which involve

- Autosomes
- Sex chromosomes, which may in turn be due to either numerical (addition or loss of one or more chromosomes) or due to structural abnormalities.

Numerical Chromosome Aberrations

Autosomal Aneuploidy

Aneuploidy means numerical gain or loss of one or few chromosomes.

- Monosomy*: It means loss of an autosome, and is incompatible with life as even one chromosome may carry many important genes.
- Trisomy*: It means addition of an autosome.

Examples

Trisomy 21 (Down's syndrome) 47, XY, +21

Trisomy 18 (Edward's syndrome) 47, XY, + 18

Trisomy 13 (Patau's syndrome) 47, XY, +13

- Polyploidy*: It means that the chromosome number is a multiple of 23, but exceeds the number 46. These are incompatible with life.

Examples: Triploidy (69 chromosomes)

Tetraploidy (92 chromosomes).

Sex Chromosome Aneuploidy

These are more common than autosomal aneuploidy, with the exception of trisomy 21. This occurs as a result of non-dysjunction (failure of homologous chromosomes to separate) during one of the meiotic divisions in oogenesis or spermatogenesis.

If the number of X chromosomes added is more, there are higher chances of the presence of mental retardation.

If the number of Y chromosomes added is more, the male is tall, aggressive in behaviour and often delinquent.

Structural Aberration of Chromosome

These arise from chromosomal breakage. The abnormalities that occur may be

- Deletion*: A segment of chromosome is lost after breakage, e.g. Cri-du-chat syndrome (deletion of short arm of chromosome 5) 46, XY, 5p-
- Translocation*: There is aberrant rejoining of the broken segments, occurring on two chromosomes.

There is, therefore an exchange of segments between two non-homologous chromosomes, e.g. Down's syndrome occurring due to translocation between chromosomes 14 and 21. Philadelphia chromosome, an acquired translocation occurring between chromosomes 9 and 22, is seen in patients with CML.

Single Gene Disorders

These occur due to mutation (change in a gene) in either one or in a pair of homologous alleles at a single locus of the chromosome.

Allele	Gene at a given locus
Homologous chromosome	Paired chromosomes

If the locus is on one of the 22 autosomes, it called autosomal (dominant or recessive) and if on X or Y chromosome, then it is called sex-linked (dominant or recessive).

Autosomal Dominant Inheritance

Disorders inherited in this manner, manifest in a *heterozygous state* (i.e. people who have one normal and one mutant allele at the locus involved).

- It is characterised by vertical transmission to subsequent generations.
- Nearly always one parent is affected.
- If the affected individual does not have an affected parent, it may be due to:
 - Illegitimacy
 - New mutation occurring in the germ cell of the unaffected parent
 - Mild affection, and so disorder not detected in parent.

Autosomal dominant traits may show variable expression (variation in severity of the same genetic disorder). Sometimes a gene may not express itself (non-penetrance) and this explains apparent skipped generations. Penetrance of a gene results in complete expression of the characteristics of the gene.

- There is 50% chance that the child of an affected parent will be affected.

Examples:

- Achondroplasia
- Facioscapulohumeral muscular dystrophy
- Gilbert's syndrome
- Hereditary spherocytosis
- Huntington's chorea
- Hyperlipoproteinaemia type II
- Marfan's syndrome
- Myotonic dystrophy
- Neurofibromatosis

10. Polycystic disease of the kidney
11. von Willebrand's disease
12. Porphyria.

Autosomal Recessive Inheritance

These disorders manifest in the *homozygous state* (i.e. people who have two mutant alleles, one on each of the homologous chromosomes, one from each parent).

- Heterozygous carriers of the single mutant allele are clinically normal.
- Mating between two heterozygotes have a 25% chance of producing affected homozygote, 50% chance of heterozygote (clinically normal) and 25% chance of normal homozygote.
- It is characterised by horizontal transmission with affected persons all in the same generation.
- If an affected individual mates with the heterozygote, then there is a 50% chance of producing an affected child and 50% chance of producing a heterozygous (clinically normal) child.

Examples:

1. Albinism
2. Ataxia telangiectasia
3. Cystic fibrosis
4. Friedreich's ataxia
5. Glycogen storage disorder
6. Limb girdle muscular dystrophy
7. Wilson's disease.

X-linked Recessive Inheritance

In these disorders, the mutant gene is carried on the X-chromosome. These disorders manifest only in the male and not in the female children (as the mutant gene on one X-chromosome is counteracted by the normal gene on the other X-chromosome. The absence of another normal X-chromosome in a male makes the disorder manifest in them).

- A mother who is a carrier will have her daughters to be carriers and all her sons affected.
- Very rarely, a woman can exhibit a X-linked recessive disorder when
 - a. She may have Turner's syndrome (45, XO)
 - b. Testicular feminisation syndrome (XY sex chromosome constitution)
 - c. She may have had a mother as a carrier and an affected father
 - d. Normal father in whom mutation occurred in the X-chromosome and a carrier mother
 - e. Affected father and normal mother in whom mutation occurred in one transmitted X-chromosome.

- f. *Manifesting heterozygote:* This occurs as a result of random inactivation (*Lyonization*), by chances of the normal X-chromosome in most of the cells.

Examples

1. Christmas disease
2. Duchenne's muscular dystrophy
3. G-6-PD deficiency
4. Haemophilia
5. Nephrogenic diabetes insipidus.

X-linked Dominant Inheritance

This condition will manifest in females also (as the effect of the mutant gene on one X-chromosome cannot be counteracted by the normal gene on the homologous X-chromosome).

- In this type of inheritance, the affected father transmits the disorder to all his daughters but to none of his sons.
- The affected mother may transmit the disorder to 50% of her children (males or females).

Example: Vitamin D resistant rickets.

Y-linked or Holandric Inheritance

- Only males are affected
- An affected male transmits the trait to all his sons but to none of his daughters.

Examples: Hairy ears, Webbed toes.

Mosaicism

In this there is existence of different chromosomal patterns in the cells of the tissue of the same individual.

Examples

Klinefelter's syndrome showing a mosaicism of XX/XXX, XY/XXY, XY/XXX.

Turner's syndrome showing a mosaicism of XO/XXY, XO/XX, XO/XXX.

Chimerism

This can occur when

- a. An ova is fertilised by sperms from two different individuals
- b. Exchange of cells via the placenta between two non-identical twins.

Examples

Ninety percent of the male twin's cells may have an XY chromosome constitution, and 10% have an XX chromosome constitution, and most of his red cells may be of blood group A and a few red cells of group B.

Ninety percent of the female twin's cells may have an XX chromosome constitution, and 10% have an XY chromosome constitution, and most of her red cells may be of blood group B and a few red cells of group A.

Multifactorial or Polygenic Inheritance

In this form of inheritance, the manifestation of a disorder is due to the presence of multiple gene mutations. Characteristics transmitted by multifactorial inheritance are intelligence, stature, skin colour, finger printing and ocular refraction. This is due to an additive effect of the genes for a particular characteristic, e.g. a tall person has more genes for tall than for short stature. Certain disorders like hypertension, DM, IHD are transmitted in this way.

Genomic Imprinting

This is a phenomenon in which there is gene inactivation on selected chromosomal regions leading to preferential expression of an allele depending on its parental origin.

Example:

1. Wilms' tumour—Chromosome 11
2. Beckwith-Wiedemann syndrome—Chromosome 11
3. Prader-Willi syndrome—Chromosome 15
4. Angelman's syndrome—Chromosome 15
5. Duchenne's dystrophy—X chromosome.

Trinucleotide Repeat

Several diseases are associated with an increase in the number of nucleotide repeats above a certain threshold. When repeat length increases from one generation to next, disease manifestations may worsen or be observed at an earlier age. This is referred to as 'Phenomenon of anticipation'.

Example:

1. Huntington's disease
2. Spinocerebellar ataxia 1,2,3,6,7,8 and 12
3. Friedreich's ataxia
4. Fragile X syndrome
5. Dystrophia myotonica
6. X chromosomal spinobulbar muscular atrophy
7. Dentato Rubro Pallido Luysian atrophy.

Mitochondrial Disorders

Mitochondrial gene is inherited through the maternal line. Hence all children from an affected mother will inherit the disease.

Example:

1. Mitochondrial encephalopathy with lactic acidosis and stroke like episodes
2. Myoclonic epilepsy with ragged red fibres
3. Neuropathy ataxia and retinitis pigmentosa
4. Lebers hereditary optic neuropathy
5. Chronic progressive external ophthalmoplegia
6. Kearns-Sayre syndrome.

Common Chromosomal Disorders

Chromosome 1

Homocystinuria
Hypokalaemic periodic paralysis
Charcot-Marie tooth disease (type 1b)

Chromosome 2

Alport syndrome (AR)
Crigler-Najjar type 1

Chromosome 3

von Hippel-Lindau

Chromosome 4

Huntington's disease
ADPKD type II
Abeta lipoproteinaemia

Chromosome 5

Retinitis pigmentosa (AR)
Werdnig-Hoffmann disease

Chromosome 6

Haemochromatosis
Ankylosing spondylitis
Spinocerebellar ataxia 1

Chromosome 7

Cystic fibrosis
Supravalvular AS
MODY type II

Chromosome 9

Tuberous sclerosis (1)
Hereditary haemorrhagic telangiectasia
Nail patella syndrome

Chromosome 10

MEN IIa
Refsums disease
Congenital erythropoietic porphyria

Chromosome 11

Sickle cell anaemia
 Thalassemia
 Wilms' tumour
 Ataxia telangiectasia
 Hereditary angioedema
 MEN I

Chromosome 12

von Willebrand's disease
 Phenylketonuria
 SCA 2

Chromosome 13

Wilson's disease
 Osteosarcoma
 Retinoblastoma

Chromosome 15

Marfan's syndrome
 Angelman's syndrome

Chromosome 16

ADPKD I
 Alpha thalassemia
 Tuberous sclerosis (2)

Chromosome 17

Neurofibromatosis type 1
 Charcot-Marie tooth disease type 1a
 Hyperkalaemic periodic paralysis
 Li-Fraumeni syndrome

Chromosome 18

Methaemoglobinaemia

Chromosome 19

Myotonic dystrophy

Chromosome 20

MODY type 1

Chromosome 21

Amyotrophic lateral sclerosis
 Progressive myoclonic epilepsy

Chromosome 22

Neurofibromatosis type 2

Chromosome Y

Gonadal dysgenesis

Chromosome X

Haemophilia A,B
 Colour blindness
 Alport syndrome
 Fabry's disease
 Duchenne and Becker muscular dystrophy.

Immunology**The Immune System and the Basis of Immunity**

The immune system is a part of body's defence system, which protects it against noxious and harmful environmental agents, as well as internal miscreants (neoplasia).

Primary Lymphoid Organs

Bone marrow
 Thymus
 Foetal liver.

Secondary Lymphoid Organs

Lymph nodes
 Spleen
 Tonsils
 Peyer's patches.

Dispersed Immune Cells

Immunocytes are dispersed between other cells, e.g. within the gut epithelium and lamina propria.

Migration of Lymphocytes

There is one way traffic of T and B cells from primary lymphoid organs into the blood stream and continuous recirculation of cells between the secondary lymphoid organs, tissues and bloodstream.

Cells Involved in Immunity

Identification of cell types is by identifying CD (Cluster of differentiation) and other surface markers on lymphocytes. This is valuable in the classification of lymphomas and its clinical diagnosis and also in research.

CD can be tested using monoclonal antibodies. There are certain groups of cells for which no antibody is available to distinguish between them. But they can be identified only by functional characteristics.

Antigen Presenting Cells

These are found in lymphoid organs and the skin. Their role is to present the antigen to lymphocytes in a

particular way, to start off the immune response. They include,

- Interdigitating cells in thymus
- Langerhans' cells of skin
- Veiled cells in afferent lymph
- Interdigitating cells in the T areas of lymph nodes
- Follicular dendritic cells in B areas of lymph nodes
- Macrophages and other non-immune cells (epithelial cells).

T-lymphocytes

They are from stem cells of the bone marrow, which have matured under the influence of a hormone or factor produced by the epithelial cells of the thymus.

T-cells perform immunoregulatory functions via their secreted products and act as effector cells capable of killing other cells.

Given appropriate stimulation, T-cells proliferate and differentiate into many subsets.

Immune Regulatory T-cells

- a. Helper T-cells (T_H)— CD_4
- b. Suppressor T-cells (T_S)— CD_8

Effector T-cells

Cytotoxic (T_C) cells— CD_8
 Mediators of delayed hypersensitivity (T_{DTH})— CD_4

B-lymphocytes

When appropriately stimulated, B cells undergo proliferation, maturation and differentiation to form plasma cells, which synthesize antibodies (immunoglobulins). Subsequently a clone of daughter cells are formed.

Neutrophil Polymorphs

They are short-lived cells which are highly concentrated in the bloodstream. But they can respond to chemotactic signals in the presence of tissue injury or infection. They marginate in the capillaries and move into the tissues where they can phagocytose and kill bacteria and other foreign materials.

Macrophages

These are derived from bone marrow precursors which differentiate to monocytes and finally settle in the tissues as mature, mononuclear phagocytes, e.g. alveolar macrophages in lung, Kupffer cells of liver, brain microglial cells, kidney mesangial cells.

Macrophages are capable of phagocytosis and killing of micro-organisms. They also secrete cytokines and influence T-cells and other important cells.

Aggregates of macrophages, granulomas are characteristic of many chronic infections and idiopathic inflammatory diseases (TB, leprosy, sarcoidosis, Crohn's disease).

Natural Killer Cells (NK Cells)

NK cells are large granular cells. They are important in resistance to viral infections and malignancy. Surface molecule of a cell, altered by virus or cancerous transformation can be recognised by NK cells, which in turn engage the infected or altered cells and kill them.

Eosinophils

They are metabolically very active and they contain granule mediators like, the toxic protein (eosinophilic major basic protein), histaminases, etc. which inactivate mast cell products. They are attracted by factors released by T-cells, mast cells and basophils, e.g. eosinophilic chemotactic factor of anaphylaxis. They aid human host defences against worms, schistosoma and are also implicated in allergic diseases such as asthma.

Mast Cell Series

Their granules contain many inflammatory and chemotactic mediators. All have receptors for IgE and are degranulated when an allergen cross links to specific IgE molecules bound to the surface of the cell.

Mast cells and basophils are involved in parasite immunity, allergic diseases and in delayed hypersensitivity reactions.

Cytokines

Cytokines are cell regulatory molecules which are essential for the regulation of growth and differentiation of lymphohaematopoietic and other cells.

All these cells take part in immune response and bring about active immunity or immunological tolerance.

The entry of 'non-self' antigens in the body triggers an immune response which includes:

1. Humoral immune response with specific antibody formation
2. Cell-mediated immunity with production of cytotoxic lymphocytes and the lymphokine secreting delayed-type T-cells
3. Establishment of immunological memory (for secondary response)
4. Specific immune unresponsiveness (immunologic tolerance).

Major Cytokines and their Biology

<i>Name</i>	<i>Major source</i>	<i>Main function</i>
Interleukin-1 α and β	B-cells, macrophages, large granular lymphocytes	Lymphocyte activation, macrophage activation, increased leucocyte-endothelial adhesion, fever, acute phase protein synthesis
Interleukin-2 (T-cell growth factor)	Activated T-cells	Activation of T-cell cytotoxic responses and induction of non-MHC restricted cytotoxic lymphocytes
Interleukin-3	T-cells	Colony stimulating factors for cells of various lineages, stimulates production and renewal of the pluripotent stem cells
Interleukin-4	Activated T-cells, mast cells	Proliferation and differentiation of B-cells, expression of MHC class II antigens on resting B-cells, modulation of host immunity and inflammatory responses
Interleukin-5 or B-cell	T-cells	Potent eosinophil differentiation and activation factor, B-cells differentiation and antibody production
Interleukin-6	Lymphoid and nonlymphoid cells (monocytes, fibroblasts, transformed T-cells)	Mediation of inflammation and immune response, production of acute phase proteins, stimulating effect on haematopoietic stem cells, costimulant of IL-2 production
Interleukin-7	Bone marrow stromal cells	Growth and differentiating factor for T-cells, viability factor for immature and nonproliferating thymocytes
Interleukin-8	Produced by wide variety of cells on induction with IL-1, TNF, lipopolysaccharides, infectious agents	Chemotactic activating factor for neutrophils, T-cells and eosinophils
Interleukin-9	T helper cells	Acts synergistically with IL-4 to potentiate antibody production, stimulates erythroid colony formation and maturation of megakaryocytes
Interleukin-10	T-cells and B-cells	Potent immunosuppressant of macrophage function, downregulation of MHC class II antigen expression on macrophages and inhibits proinflammatory cytokines (IL-1, TNF, and IL-6)
Interleukin-11		Inflammatory mediator (stimulation of hepatic acute phase reactants), growth factor for megakaryocyte colonies, has synergistic effects on the growth factor activity of IL-3 and IL-4 on early haematopoietic progenitors
Interleukin-12	Macrophages and B-cells	Production of interferon gamma from T-cells and NK cells, differentiation of helper T-cells
Interferon- α and β	Leucocytes, fibroblasts	Antiviral, induces MHC class I antigens on cells
Interferon- γ	T-cells, NK cells, fibroblasts	Induces MHC class II antigens, macrophage activation, \uparrow endothelial cell-lymphocyte adhesion
Tumour necrosis factor (TNF- α , cachectin)	Macrophage, lymphocytes	Activation of cytotoxic cells, macrophages, granulocytes; \uparrow leucocyte-endothelial cell adhesion; cachexia
Tumour necrosis factor (TNF- β)	T-cells	-do-
Macrophage colony stimulating factor (M-CSF)	Stromal cells, macrophages and fibroblasts	Stimulates macrophage function and activation; \uparrow expression of MHC class II antigen on macrophages
Granulocyte colony-stimulating factor (G-CSF)	Stromal cells, monocytes macrophages, endothelial cells	\uparrow number of circulating granulocytes
Granulocyte-macrophage colony stimulating factor	Stromal cells, fibroblasts, T-cells and endothelial cells	Growth of progenitors for granulocytes, monocytes and erythrocytes; causes eosinophilia; enhances phagocytosis
Transforming growth factor (TGF)		Enhances fibrosis, neoangiogenesis; induces inflammation of mononuclear cell type

Clinical Aspects of Immunology

The immune system protects our body against exogenous substances, microbes and possibly tumours, but immune responses also damage normal host tissues and react to homologous antigens and sometimes to endogenous antigens, the basis of autoimmune disorders.

Disorders related to the immune system falls into three groups:

1. Hypersensitivity reactions
2. Autoimmunity
3. Immunodeficiency states.

Immunoglobulins

There are five types of immunoglobulins namely, IgG, IgA, IgM, IgD and IgE.

IgG

IgG constitutes the major portion of Ig (70%). It is distributed equally between the blood and extracellular fluids. IgG is the only immunoglobulin transported across the placenta and it provides passively acquired immunity to the newborn during its early life. IgG participates in immunological reactions such as complement fixation, precipitation and neutralisation of toxins and viruses. It protects against infectious agents which are active in blood and tissues. IgG suppresses the homologous antibody synthesis when passively administered and this property is utilised in the isoimmunisation of women by administration of anti-Rh (D) IgG during delivery. IgG is a late antibody and makes its appearance after IgM. There are four subclasses—IgG₁, IgG₂, IgG₃ and IgG₄.

IgA

IgA constitutes 20% of total immunoglobulins. The major sites of IgA synthesis are gut mucosa and lamina propria of respiratory tract. Secretory IgA confers local immunity by forming an antibody paste and prevents infection by bacteria or virus and it also regulates commensals of gut.

IgM

It is a macromolecule which is predominantly intravascular. It is the earliest immunoglobulin synthesised by the foetus from about 20 weeks of age. Presence of IgM in the foetus or newborn indicates intrauterine infection and its detection is useful in the diagnosis of congenital syphilis, toxoplasmosis and rubella.

The isohaemagglutinins (anti-A, anti-B) and many other natural antibodies are IgM. Antibodies to typhoid

'O' antigen (endotoxin) and WR antibodies in syphilis are also of IgM class. IgM is responsible for protection against blood invasion by micro-organisms. IgM deficiency is often associated with septicaemias.

IgD

It is helpful in the maturation and regulation of B-lymphocytes.

IgE

It is necessary for immediate hypersensitivity reactions and also useful in defence against helminths. IgE is produced in the linings of respiratory and intestinal tracts. Deficiency of IgE is associated with IgA deficiency in individuals with impaired immunity.

Disorders of Immunoglobulins

Light Chain Disease (Bence-Jones Proteins)

This is found typically in multiple myeloma. This protein coagulates when urine is heated to 60°C and redissolves at 80°C in patients with myeloma. Multiple myeloma may affect plasma cells synthesising IgG, IgA, IgD or IgE.

Heavy Chain Disease

This lymphoid neoplasia is characterised by the over production of the Fc portion of immunoglobulin heavy chains.

Cryoglobulinaemia

This is a condition in which there is formation of a gel or a precipitate on cooling the serum, which redissolves on warming. Most cryoglobulins consist of either IgG, IgM or their mixed precipitates.

Immunodeficiency States

Primary Immunodeficiency Disorders

Humoral Immunodeficiencies

- a. X-linked hypogammaglobulinaemia
- b. Transient hypogammaglobulinaemia of infancy
- c. Common variable, unclassifiable immunodeficiency
- d. Selective IgA deficiency.

T-cell Immunodeficiencies

- a. DiGeorge syndrome
- b. Chronic mucocutaneous candidiasis.

Combined Immunodeficiencies

- a. Wiskott-Aldrich syndrome
- b. Nezelof's syndrome
- c. Severe combined immunodeficiency
- d. Immunodeficiency with ataxia telangiectasia
- e. Immunodeficiency with lymphotoxins
- f. Immunodeficiency with thymoma
- g. Immunodeficiency with short limbed dwarfism.

Phagocytic Deficiency Diseases

- a. Job's syndrome
- b. Chédiak-Higashi syndrome
- c. Lazy leucocyte syndrome
- d. Hyper IgA syndrome
- e. Myeloperoxidase deficiency
- f. Tuftsin deficiency
- g. Leucocyte G-6-PD deficiency
- h. Chronic granulomatous disease
- i. Schwachman's disease.

Complement Deficiency Diseases

1. Deficiency of a complement component
 - a. C₃ deficiency causes recurrent pyogenic infections
 - b. C₆, C₇, C₈ deficiency causes Neisserial infections
 - c. C₁, C₂, C₄ deficiency results in immune complex like or lupus like disorders.
2. Deficiency of a complement inhibitor
 - a. Autosomal dominant C1 esterase inhibitor deficiency (Hereditary angioedema).

Secondary Immunodeficiencies



Causes

1. Poor nutrition (proteins, calories, micronutrients)
2. Old age
3. Post-operative states (due to general anaesthesia)
4. Loss of protective commensal gut bacteria (broad spectrum antibiotics)
5. Irradiation
6. Cancer chemotherapy
7. Immunosuppressive drugs
8. Diseases like AIDS, lepromatous leprosy in later stages.

Hypersensitivity Reactions

Type I Hypersensitivity (Anaphylactic, Reagin Dependent)

This is mediated by IgE antibodies bound to mast cells and basophils formed in response to particular antigen

(allergen). IgE protects against parasitic infections. Reexposure of antigen in sensitised individuals results in release of primary and secondary mediators from mast cells due to degranulation.

Systemic Anaphylaxis

This occurs when an antigen is administered orally or parenterally. Even minute doses may induce shock in the appropriate host. Pruritus, urticaria, laryngeal oedema progressing to laryngeal obstruction shock and death within minutes can also result.

Local Anaphylaxis

It affects 10% of population and includes urticaria, angioedema, rhinitis, and atopic asthma.

Type II Hypersensitivity

This reaction is mediated by antibody against intrinsic or extrinsic antigens adsorbed on the cell surface or on other tissue components.

Complement Dependent Reactions

Examples are:

- a. Transfusion reactions
- b. Erythroblastosis fetalis
- c. Autoimmune thrombocytopenia
- d. Drug reactions
- e. Goodpasture's syndrome.

Antibody Dependent Cell-mediated Cytotoxicity

This reaction may be important for parasitic infections or tumours and may play a major role in graft rejection.

Antireceptor Antibodies

Examples are:

- a. Myasthenia gravis
- b. Grave's disease.

Type III Hypersensitivity (Immune Complex-mediated)

This is mediated by antigen-antibody complexes (immune complexes), which are formed either in the circulation or at the sites of antigen deposition. Antigens can be exogenous or endogenous.

Systemic Immune Complex Disease

Acute serum sickness: This is caused by administration of large amounts of foreign serum (horse serum). About a week after inoculation, anti-horse serum antibodies are formed and react with foreign antigen to form circulating immune complexes.

Small immune complexes (antigen excess) deposit within capillary or arteriolar walls causing vasculitis. The affected tissues are renal glomeruli (causing glomerulonephritis), joints (arthritis), skin, heart and serosal surfaces.

Large immune complexes (antibody excess) are cleared by phagocytes, ending the disease process. Immune complexes also aggregate platelets and activate factor XII, involving coagulation cascade and kinin systems.

Local Immune Complex Disease (Arthus Reaction)

This is a localised tissue vasculitis and necrosis due to focal formation or deposition of immune complex or planting of antigen in a tissue with immune complex formation *in situ*.

Type IV Hypersensitivity

This reaction is induced by sensitised T-cells which on contact with the specific antigen, release lymphokines that cause biological effects on leucocytes, macrophages and tissue cells.

Two types of delayed hypersensitivity are:

- Tuberculin type (Developed in many infections with bacteria, fungi, viruses and parasites)
- Contact dermatitis type (Resulting from skin contact with a variety of chemicals like nickel, chromium, drugs like penicillin and toileteries).

Histocompatibility Antigens

The most important of these antigens are grouped in the Major Histocompatibility Complex (MHC) on short arm of chromosome 6. It contains genes coding for 'Human Leucocyte Antigens' (HLA).

Class I Antigens

These are present on all nucleated cells and platelets. They elicit antibodies in non-identical individuals. They bind only to those processed antigens which are synthesised endogenously. MHC-I antigens present processed antigens to cytotoxic T-cells (CD_8). T-cell receptors recognize only antigen-MHC complexes. CD_8 T-cells bind and kill only infected cells that bear self class I antigens (MHC restriction).

Class II Antigens

MHC-II antigens are coded in the HLA-D region. These are characteristically confined to antigen presenting cells. They typically bind and present exogenous

antigens to CD_4 T-cells (helper T-cells) and they also exhibit MHC restriction.

Class III Proteins

Some components of the complement system (C_2 , C_4 , Bf) and some cytokines (TNF- α and β) are encoded within the MHC cluster. These are not histocompatibility antigens.

Transplant Rejection

Hyperacute Rejection

When the recipient has been previously sensitised to antigens (following blood transfusion, previous pregnancy) in graft by developing antidonor IgM, IgG antibodies and complement, hyperacute rejection sets in immediately within one to two days, i.e. immediately after revascularisation.

Acute Rejection

It occurs within a few days after transplantation, after stopping immunosuppressive drugs.

Chronic Rejection

It occurs over months to years and is caused by several types of immune reaction.

Diseases Associated with HLA

HLA antigen	Diseases
HLA B27	Ankylosing spondylitis Reiter's disease
DR2	Multiple sclerosis
A3	Haemochromatosis
B13	Psoriasis
B8, DR3, DR4	IDDM
B8, DR3	Addison's disease Thyrotoxicosis Myasthenia gravis Coeliac disease

Autoimmune Diseases

If an individual mounts a significant immune response against his/her own body constituents as a result of a defect in immunological tolerance, secondary to some exogenous factors, e.g. virus, autoimmune disorders occur.

Organ Specific Disorders

Hashimoto's thyroiditis
Primary myxoedema

Thyrotoxicosis
Pernicious anaemia
Autoimmune atrophic gastritis
Autoimmune Addison's disease
Type I diabetes
Goodpasture's syndrome
Myasthenia gravis
Sympathetic ophthalmia
Autoimmune haemolytic anaemia
Primary biliary cirrhosis
Chronic active hepatitis
Sjögren's syndrome.

Non-organ Specific Disorders

Rheumatoid arthritis
Dermatomyositis
Progressive systemic sclerosis
SLE.

Immunology and Malignancy

Tumour Antigens

These are present in malignant cells and induce immune response when the tumour is transplanted into syngenic animals. Such tumour specific antigens which induce rejection of tumour transplants in immunised hosts are termed 'tumour specific transplantation antigens' (TSTA).

Second type of antigens are foetal antigens. These are found in embryonic cells and malignant cells and not in normal adult cells, e.g. Alfafetoprotein in hepatoma, carcinoembryonic antigen in colonic cancers especially with metastasis. Occasionally found in alcoholic cirrhosis also.

Inefficiency of immunological surveillance mechanism, as a result of ageing, congenital or iatrogenic immunodeficiency may lead to increased incidence of cancer.

Chapter 2

Nutrition



Bitot's spot



Corneal xerosis



Xerophthalmia



Dehydration



Anaemia



Pellagra



Angular stomatitis

Phenoderma



Beriberi

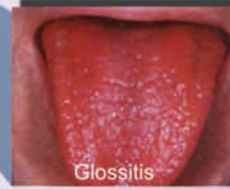

Koilonychia



Rachitic rosary



Rickets

Obesity
Easy bruisability
Infections

Marasmus/
Kwashiorkor



Acrodermatitis
enteropathica

Peripheral
neuropathy



Scurvy



Balanced nutrition is essential to maintain health and to prevent diseases. We eat intermittently but the energy needs are continuous. Neurophysiologic mechanisms control appetite and eating behaviour. Energy needs of the body during feeding are met by the nutrients absorbed from gastrointestinal tract and at other times, body's needs are met by the release of energy from stores. The excess amino acids, fatty acids and glucose are stored as proteins, triglycerides and glycogen. The above process is under the control of insulin.

Nutrition plays a major role in causing certain systemic disorders:

Coronary heart disease, diabetes mellitus, hypertension (excess lipids, obesity, sodium intake) renal stones, gallstones, dental caries, and carcinomas of stomach, liver and large bowel. Either excess or poor nutrition can cause disease and diseases can cause malnutrition.

Classification of Nutrients

- I. Water
- II. Macro-nutrients
 1. Carbohydrates.
 - A. Energy yielding
 - Monosaccharides (glucose, fructose, ribose)
 - Disaccharides (lactose, maltose, sucrose)
 - Polysaccharides (starch)
 - B. Non-energy yielding
 - Dietary fibres
 2. Fats
 3. Proteins
- III. Micro-nutrients
 - A. Organic micro-nutrients
 - Vitamins (not synthesised in the body)
 - B. Inorganic micro-nutrients
 - i. Electrolytes (sodium, potassium, chlorine)
 - ii. Minerals (calcium, phosphorus, iron, magnesium)
 - iii. Trace elements (Zinc, copper, iodine, selenium, chromium and manganese).

Water

Water accounts for 60 to 65% of the body weight (75% at birth and 50% in old age). Water is distributed between intracellular (40%) and extracellular (Plasma and interstitial fluid 20%) compartments. Daily water intake for an average adult will vary between 1 and 3 litres depending on the climate.

Energy Yielding Macro-nutrients

Carbohydrates

An average adult consumes 55 to 65% of calories as carbohydrates and they form the major source of energy. 200 gm of carbohydrate is required/day. 1gm of carbohydrate yields 4 kilocalories (1 kcal = 4.184 kilo joules). Ketosis is likely to occur when the intake is less than 100 gm/day.

Source of Carbohydrates

1. Available as sugars—Mono and disaccharides
 - Intrinsic sugars—fruits and milk (good for health)
 - Extrinsic sugars—cane sugar and beet-root sugar (dental caries)
2. Available as polysaccharides—Starch, glycogen
 - Starch is available in cereals (wheat, rice, maize, etc.), roots (Potatoes and Cassava), plantains and legumes.

Glycaemic Index

Two hour plasma curve after 50 gm of carbohydrate in a given food divided by a curve of 50 gm glucose in water. Glycaemic index is high for glucose, bread, and potatoes and low for legumes and whole grain cereals. Carbohydrates with low glycaemic index are preferable for diabetic patients.

Non-energy Yielding Carbohydrates

Dietary Fibre

It is the natural packing of plant foods and not digested by human enzymes. They are of two types:

A. Water Soluble Fibres

Oat bran, beans, pectin and guar gum. They act in upper GIT and induce early satiety, flatten glucose tolerance curve and decrease serum cholesterol.

B. Water Insoluble Fibres

Wheat bran—hemicellulose of wheat because of increased water holding capacity increases the bulk of stool and prevents constipation, diverticulosis and cancer colon. Flatus formation is common with fibre diet.

Daily requirement is 15 to 20 gm/day.

Fats

An average adult consumes 30 to 40% of calories as fats. 1 gm of fat yields 9 kcal of energy. It is the cause for obesity in sedentary people.



There are three types of fats.

1. Saturated fats—Ghee, palmitic acid, myristic acids—
They increase plasma LDL and total cholesterol. They predispose to CAD.
2. Monounsaturated fatty acids—Oleic acid,
3. Polyunsaturated fatty acids—Linoleic acid in plant seed oils and its derivatives—gamma linolenic acid, arachidonic acids are the essential fatty acids. They are precursors of prostaglandins, eicosanoids and they form part of the lipid membrane in all cells.

The omega 3 series of polyunsaturated fatty acids occur in fish oil.

By antagonising thromboxane A-2, they inhibit thrombosis. Their use is advocated to prevent hyperlipidaemia and CAD and to reduce triglycerides.

Stage I Diet

It is advocated to prevent hyperlipidaemia and CAD.

It consists of 10% of each type of fats with daily cholesterol less than 300 mg/day.

Stage II Diet

It is advocated in hyperlipidaemia when stage I diet fails to achieve the goal.

It consists of 7% of each type of fat with daily intake of cholesterol less than 200 mg.

Proteins

Proteins form the basic building units of tissue. They play the major role in the formation of enzymes and hormones and also in the transport mechanisms. Unlike carbohydrates and fats, no proteins are stored in the body. The amino acids in excess proteins are transaminated and the non-nitrogenous portion is stored as glycogen or fat. Protein requirements are highest during growth spurts—infancy and adolescence. (Protein requirement during these stages—1.5 to 2 gm/kg/day).

There are 20 different amino acids of which 9 amino acids are essential—Tryptophan, threonine, histidine, leucine, isoleucine, lysine, methionine + cysteine, phenylalanine + tyrosine and valine.

They are essential for the synthesis of different proteins in the body.

Proteins of animal origin—eggs, milk, meat—have higher biological value than the proteins of vegetable origin.

An average adult requires 10 to 15% of total calories as proteins.

It is equivalent to 1 gm/kg body weight.

Daily Energy Requirements

* Energy requirements depend on—Age, sex, body weight, lactation, climate, (lower calories for tropical climate and higher calories for colder climate).

Type of work	Males/kcals/d	Females/kcals/d
Rest	2000	1500
Light	2500	2000
Moderate	3000	2250
Heavy	3500	2500

Growing children, pregnant and lactating mother need more calories. Brain uses glucose at the rate 5 gm/hour (Preference for ketones when ketone levels are high).

Balanced Diet

Balanced diet contains carbohydrates, protein, fat, mineral, vitamins and trace elements in adequate quantum and proportion in order to maintain good health.

Classification of Nutritional Disorders

1. **Under-nutrition**
Quantitative deficiency
In children—Marasmus
In adults—various forms of starvation, anorexia nervosa, bulimia, etc.
2. **Malnutrition**
Qualitative deficiency
Protein deficiency—PCM or PEM
Vitamin D—rickets
Vitamin C—scurvy, etc.
3. **Excess nutrition**
Quantitative—Obesity
4. **Excess nutrition**
Qualitative
Excess cholesterol—hyperlipidaemia
Excess vitamins—hypervitaminosis A, D, etc.
5. **Effect of toxins in food**
Migraine, urticaria, coeliac disease, lathyrism

Pathological Causes of Nutritional Disorders

- I. **Defective intake**
It can be due to:
 1. Poor economic status
 2. Loss of appetite—excess coffee, tea, alcohol, smoking

- Systemic disorders—renal failure, liver cell failure
 Psychiatric disorders—depression, anorexia nervosa
- Persistent vomiting—organic obstruction, bulimia
 - Food faddism
 - Prolonged parenteral therapy.
- II. *Defective digestion and absorption:*
- Hypo or achlorhydria
 - Various types of malabsorption syndromes (steatorrhoea, GJ)
 - Prolonged use of antimicrobials.
- III. *Defective utilization:*
- End organ failure—cardiac failure, hepatic failure, renal failure
 - Severe systemic infections
 - Malignancy of various organs.
- IV. *Excessive loss of nutrients:*
 Protein losing enteropathy, nephrotic syndrome, enteric fistulas.
- V. *Altered metabolism:*
 Hyperthyroidism, diabetes mellitus, etc
 Trauma, prolonged fever, malignancy, burns, surgery.
- VI. *Increased requirements:*
- Pregnancy and lactation
 - Growth—infancy, childhood, adolescence.

Effects of Malnutrition

- Reduced inflammatory response (cellular and humoral) to infection
- Inability to cough due to muscle wasting, leading to pneumonia and bronchopneumonia
- Impaired wound healing
- Reduced haemopoiesis
- Prolonged drug metabolism
- Altered mental function
- Inadequate water intake—dehydration
- Bedsore and ulcers on pressure points.

Protein Energy Malnutrition (PEM)

It may be primary due to inadequate intake of protein (famine), or secondary due to defective intake, or digestion, or absorption, or altered metabolism and or increased demand. The commonly associated illnesses with secondary PEM are AIDS, CRF, inflammatory bowel disease, intestinal malabsorption, and malignancy.

PEM in Young Children

There are two types of malnutrition—Marasmus, Kwashiorkor and a combined form—Marasmic-kwashiorkor.



Fig. 2.1: Marasmus

Marasmus

Body weight is reduced below 60% of the WHO standard.

Early weaning from breastfeeding and poor diet low in energy, protein and essential nutrients are the causes. Poor hygiene leading to gastroenteritis and further malnutrition.



Clinical Features

Child is wasted, with bone and skin with no subcutaneous fat and poor muscle mass (Fig. 2.1).

Gaseous distension of abdomen with diarrhoea can occur.

In contrast to kwashiorkor, there is no oedema, skin or hair changes. There is no anorexia.

Kwashiorkor

It is almost a pure form of protein malnutrition, occurring in the second year of life in a child weaned from breastfeeding on to a starchy diet with low protein.

Secondary infection like-malaria, AGE, measles, etc (increased protein requirement) further precipitate protein malnutrition.



Clinical Features (Fig. 2.2)

- The child is apathetic, irritable and drowsy.
- Fairly intact subcutaneous fat and pitting oedema.
- The child is stunted and puberty is delayed.



Fig. 2.2: Kwashiorkor—generalised oedema

Skin changes (Fig. 2.3)—Maximal around napkin area—symmetrical—pigmented and thickened—Flaky paint mosaic like appearance with fissuring (Crazy pavement appearance) It is also seen over the areas of pressure and trauma.

Hair changes—The hair becomes thin, sparse, brownish and lusterless. They may fall-off and can easily be pulled. Partial correction leading to alternate bands of pigmentation and de-pigmentation of the hair.



Fig. 2.3: Skin changes kwashiorkor

Pathology

Acute protein depletion affecting liver, pancreas, and gut. Liver cannot synthesise albumin due to depletion of amino acids leading to hypoproteinaemia and oedema. There may be associated deficiency of vitamins and minerals. PEM can be mild or moderate or severe.

PEM in Adults

The primary form is more of undernutrition. It may be due to anorexia, insufficient food, increased demand and increased energy losses. Depletion of vitamins and minerals can also occur.

Starvation induced undernutrition can be:

- A. Mild undernutrition: 80% of the standard weight or BMI 20 to 18.
- B. Moderate undernutrition: 70% of the standard weight or BMI 18 to 16.
- C. Sever undernutrition: Less than 70% of the standard weight or BMI less than 16.



Clinical Features

- Loss of weight and weakness
- Craving for food and intolerance to cold
- Nocturia and amenorrhoea
- Loss of libido and impotence
- Lax, dry skin with loss of turgor
- Loss of hair with thinning
- Muscle wasting and loss of subcutaneous fat
- Oedema with normal albumin level
- Subnormal temperature—bradycardia—hypotension
- Distended abdomen with diarrhoea
- Depression, introversion and loss of initiative
- Depressed tendon jerks and secondary infections.

Infections Associated with PEM

- Streptococcal and staphylococcal skin infections
- Gastroenteritis and gram-negative septicaemia
- Pulmonary tuberculosis, pneumonia and bronchopneumonia
- Helminthic infestations
- Viral infections like measles, herpes simplex.

Systemic Disorders in PEM

PEM impairs the function of all organs.

Gastrointestinal Tract

Atrophy of intestinal villi—reduced quantity and quality of gastric, pancreatic and bile secretions, leading to malabsorption.

Cardiovascular System

Atrophy and patchy necrosis, reduced myocardial mass and involvement of conduction system.

Small heart with reduction in stroke volume and cardiac output.

Respiratory System

Atrophy of intercostal muscles and other muscles of respiration including diaphragm.

Decreased ventilatory derive—impaired lung function and vital capacity.

Endocrine System

Insulin, tri-iodothyronine and thyroxine levels are decreased and levels of growth hormone and cortisol are increased.

These changes lead to increased catabolism of muscle protein and enhancement of lipolysis and gluconeogenesis. Primary gonadal dysfunction is common in adults.

Immunologic Functions

Impaired cell-mediated and humoral immunity.

- T and B lymphocyte functions impaired.
- Total lymphocyte count is decreased and there is delayed skin hypersensitivity (tuberculin test, etc) (Fig. 2.4).
- Wound healing is delayed.



Investigations

1. Measure body weight, mid-arm circumference, and skin-fold thickness and calculate BMI.
2. Blood: Hb, TC, DC, ESR—leukopenia, anaemia, thrombocytopenia, decreased Hb level and normal ESR.



Fig. 2.4: Aphthous ulcer

Assessment of PEM Status

Tests	Moderate PEM	Severe PEM
Percentage of pre-morbid Wt	80 to 90	Less than 80
Percentage of ideal body Wt	60 to 80	Less than 60
Hand grip strength	60 to 70	Less than 60
Serum albumin gm/L	20 to 30	Less than 20
Serum transferrin gm/L	1 to 1.5	Less than 1
Total lymphocyte/mL	800 to 1200	Less than 800
Delayed skin hypersensitivity Test (Tuberculin, etc)	5 mm	Less than 5 mm

Differentiation between Marasmus and Kwashiorkor

	Marasmus	Kwashiorkor
Nutrient	Deficiency of proteins and calories and other nutrients	Protein deficiency
Age	Below 1 year	1 to 4 years
Weight	Less than 60%	60 to 80%
Appearance	Emaciated	Less degree of emaciation
Weaning	Early and abrupt	Late gradual
Oedema	Absent	Pitting oedema
Skin and Hair		
Changes	Mild	Marked
Anorexia and Apathy	Absent	Present
Liver	Not enlarged	Fatty enlarged liver.

3. Serum proteins—Low albumin.
4. Serum T3 and T4—Levels are decreased.
5. Cortisol and growth hormone—Levels are increased.
6. X-ray chest.
7. ECG.



Management

Good nursing, frequent feeding and prevention of intercurrent infections.

Protein intake has to be increased—instead of normal 1 gm/kg—increase it to 2 to 3 gm/kg/day. Supplement vitamins and minerals. Correct hypothermia, hypoglycaemia, hypokalaemia, dehydration, acidosis and electrolyte imbalance.

The National Institute of Nutrition, Hyderabad recommends an energy –Protein rich mixture to treat PEM at home.

Whole wheat	40 gm
Bengal gram	16 gm
Groundnut	10 gm
Jaggery	20 gm



It supplies 330 calories and 11 gm of protein.

This can be mixed with milk or water and can be taken 5 to 6 times/day.

Prevention of PEM (UNICEF): Mnemonic—GOBI FFF

G for growth monitoring

O for oral re-hydration

NaCl (3.5 gm) + NaHCO₃ (2.5 gm) + KCl (1.5 gm) + glucose (20 gm) or sucrose (40 gm/L) of water.

B for breastfeeding

I for immunisation

Against measles, diphtheria, mumps, tetanus, tuberculosis, and polio

F—Supplementary feeding

F—Female child care

F—Family welfare.

Vitamins

Vitamins are organic compounds in food, which are required in small amounts and are not synthesised in human body. They are classified into fat-soluble vitamins (A, D, E, and K) and water soluble vitamins (B and C). Fat-soluble vitamins are stored in liver and deficiency manifests only when stores are depleted. Excess intake of fat-soluble vitamins causes hyper-vitaminosis. Water-soluble vitamins are not stored and excreted in urine.

Vitamin A (Retinol)

Vitamin A is found in foods of animal origin and the pro-vitamin beta-carotene is present in plant tissues. It is necessary for clear vision in dim-light and maintains the integrity of epithelial tissues.

Sources:

Liver, egg, chicken, butter, cereals, green leafy vegetables, carrots, yellow pumpkin, papaya, tomatoes, fish liver oils.

Average daily requirement: 1000 µg

A dose of 1 µg is equivalent to 3 international units of vitamin A and 6 µg of carotenoids.

Normal serum level is 20 µg/dl. Less than 10 µg/dl indicates deficiency.

Functions of Vitamin A

Vision

It provides the molecular basis for visual excitation in rods and cones.

It induces differentiation of epithelial cells.

In deficiency states mucus-secreting cells are replaced by keratin producing cells.

It is required for growth and reproduction.

Anti-infective vitamin—Increased incidence of respiratory and gastrointestinal infections in deficient state.

It has antioxidant activity.

Vitamin A is required for reproduction, growth and maintenance of life.

Skin-mucous membrane—Hyperkeratinisation of the epithelium lining the follicles results in follicular hyperkeratosis or phrenoderma. An associated EFA deficiency aggravates this condition.



Causes of Deficiency

1. Intestinal malabsorption and malnutrition
2. Defect in storage—liver disease
3. Enhanced renal excretion—proteinuria
4. Prolonged periods of total parenteral nutrition
5. Increased demand—pregnancy.



Clinical Features

1. Night blindness—It is the earliest sign.
2. Xerophthalmia—Dry thickened, pigmented bulbar conjunctiva with oval or triangular glistening white spots—*Bitot's spots* (Fig. 2.5).

Corneas become cloudy, soft (keratomalacia) and undergoes ulceration and necrosis.

It leads to perforation, prolapse of the iris and endophthalmitis and ultimately blindness.

WHO Classification of Vitamin A Deficiency

1. Primary
 - X-1A Conjunctival xerosis
 - X-1B Conjunctival xerosis + Bitot's spots



Fig. 2.5: Bitot's spot

- X-2 Corneal xerosis
- X-3A Corneal ulcer—< 1/3 of cornea involved
- X-3B Corneal ulcer—> 1/3 of cornea involved—keratomalacia
- 2. Secondary
 - X-N Night blindness
 - X-F Xerophthalmic fundus
 - X-S Corneal scars



Treatment

Night blindness and xerosis—30,000 IU of vitamin A daily for one week.

Corneal damage—medical emergency—20,000 IU/kg/day of vitamin A for 5 days.

Risk of vitamin A deficiency—2,00,000 IU orally for 2 days. (Especially WHO develop measles).

Prevention

In malnourished children—Two oral doses of 2,00,000 IU or 1,00,000 IU/IM twice in a year.

Excess Carotenes

Carotenaemia

It is due to excessive intake of vitamin A precursors in foods, mainly carrots.

It causes yellow colouration of skin including palms and soles.

In contrast to jaundice, the sclerae are not involved and remains white.

The serum is also yellow in colour.

These changes disappear on omission of carrots.

Vitamin A Toxicity

Hypervitaminosis A is due to excessive intake of fish liver, polar bear liver or therapeutic over dose.

Acute Toxicity

Headache, nausea, vomiting, abdominal pains, dizziness, papilloedema, bulging fontanel in infants and followed by generalised desquamation of skin in a few days.

Chronic Toxicity

Ingestion of 25,000 IU or more/day for a long time

Bone and joint pains, hyperostoses, hair loss, dry and fissured lips.

Benign intracranial hypertension, pruritus, weight loss and hepatosplenomegaly.

Recovery is usual, both in acute and chronic toxicity on discontinuing vitamin A.

Vitamin D

Vitamin D is essential for the metabolism of calcium and phosphorus and for the formation of bone. It enhances the absorption of above minerals from the gut, their mobilisation from bone and re-absorption of phosphorus and calcium from the kidneys.

Vitamin D is not a vitamin but a hormone. Dietary supplements are not required when adequately exposed to sunlight.

There are two forms of vitamin D.

Vitamin D₂ (calciferol or ergocalciferol) is obtained by ultraviolet irradiation of plant origin ergosterol.

Vitamin D₃—Cholecalciferol is formed from 7-dehydrocholesterol present in the epidermal cells of skin by exposure to sunlight.

Dietary Sources

Fish liver oils, eggs, liver, milk, cheese, butter.

Daily Requirements

- Pre-school children – 10 microgram (400 IU/day)
- Children and adults – 5 microgram (200 IU/day)
- Pregnancy and lactation – 10 microgram (400 IU/day)

Metabolism

Vitamin D₂ and D₃ are identical in potency and generally referred as vitamins D.

- First hydroxylation takes place in liver and 25-hydroxy vitamin D is formed. It is further hydroxylated in kidney into the most active 1,25 dihydroxycholecalciferol {1,25(DH₂)D₃} or (calcitriol).



Causes of Vitamin D Deficiency

1. Intestinal malabsorption—pancreatic insufficiency, coeliac disease, biliary tract obstruction.
2. Kidney disease—impaired production of D₃.
3. Lack of exposure to sunlight.
4. Defective metabolism—either due to renal disorders or drugs like phenytoin, rifampin.

In children it causes rickets and in adults osteomalacia.

Rickets

Age incidence 1 to 2 years.

Delayed milestones except speech, irritability, and prominent abdomen.

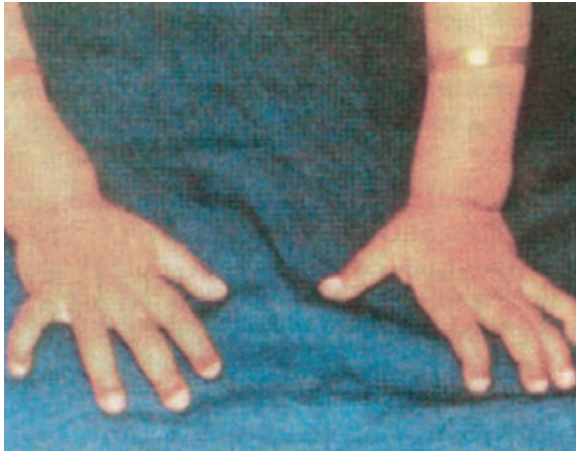

Fig. 2.6: Rickets—widening of wrist joints

Skeletal Manifestations

- In less than 1 year—craniotabes—abnormal softening of the skull in the occipital region.
- In children 1 year or more—‘hot cross bun’ appearance due to frontal and parietal bossing.
- Larger head and delayed closure of anterior fontanelle.
- Delayed dentition with defective enamel.
- Permanent teeth also show defective hypoplastic enamel with grooving, and pitting with high risk of caries.

Rachitic rosary—Costochondral junctions are enlarged and beaded.

Pigeon chest—Forward projection of sternum.

Harrison’s sulcus—A horizontal groove along the attachment of diaphragm due to contraction pulling the softened bony cage.

Spine—Kyphosis, scoliosis and lordosis.

Limbs—Widened epiphyses of wrists and ankles (Fig. 2.6)—bending of long bones femur, tibia, fibula—resulting in knock knees and coxa vara (Fig. 2.7).

General manifestations—Hepatosplenomegaly, tetany, convulsions, and frequent respiratory infections.

Hypophosphataemic rickets—Either familial inherited or acquired renal tubular defects leading to defective renal tubular re-absorption of phosphates.



Investigations

1. Hypophosphataemia
2. Hypocalcaemia
3. Raised serum alkaline phosphatase



Fig. 2.7: Rickets—bow legs

4. Radiological features—Widened (flaring) and irregular (fraying) of distal ends of long bones with cupping. Decreased density and increased trabeculations of shafts with subperiosteal osteoid formation giving a double contour appearance to the shaft.

Osteomalacia

Adults manifest with defective mineralisation of newly formed matrix. It manifests with bone pain, severe malaise, proximal muscle weakness, difficulty in climbing stairs, getting up from sitting position and waddling gait. Bone and muscular tenderness on pressure and associated pseudo-fractures and fractures of ribs and pelvis are common.

Radiological Features

Pseudo-fractures—linear zones of decalcification along the course of major arteries (Milkman’s line and Looser’s zones).

Common Sites

Pubic rami, ischium, neck of the femur, ribs and vertebrae

“Cod-fish”—vertebrae:

Compression causing widening of intervertebral space produces biconcave vertebrae.

Vitamin D resistant rickets is due to defective tubular clearance of phosphates.

Osteomalacia with normal calcium, phosphate, and vitamin D:

1. Primary non-mineralisation defect
Hereditary—Fluoride therapy
2. Defective matrix synthesis
Fibrogenesis imperfecta
3. Miscellaneous
Aluminium bone disease
Parenteral alimentation



Management

Twenty-five to fifty microgram (1000 to 2000 IU) of vitamin D, along with 500 to 1000 mg of calcium daily are sufficient for both rickets and osteomalacia.

Duration of therapy: 6 to 12 weeks may be required or 40,000 IU/IM injections once in two weeks. Three to four injections are required.

Recurrence can be prevented by daily intake of 400 IU of vitamin D.

If osteomalacia is due to renal disease give alfacalcidol 1 µg/day PO and adjust the dose according to plasma calcium. Monitor plasma calcium. Otherwise treatment of osteomalacia is similar to rickets.

Hypervitaminosis D

It causes hypercalcaemia. It is due to excess vitamin D intake.



Clinical Features

Constipation, nausea, vomiting, drowsiness and renal damage.

Metastatic calcification—kidneys, lungs, gastric mucosa, soft tissues and arteries.

Prevention

Serum calcium level should be monitored regularly for patients on high dose vitamin D therapy. When serum calcium raises above 10.5 mg/dl, vitamin D should be stopped.

Vitamin E

Alpha tocopherol is the most potent of the 8 naturally occurring substances with vitamin E activity.

It is one of the main fat-soluble antioxidants in addition to carotenoids.

It prevents oxidation of PUFA—Polyunsaturated fatty acids in cell membranes by free radicals.

It reduces atherogenesis.

Daily requirement:

- For men — 10 mg
For women — 5 mg

Sources:

Vegetable oils, whole-grain cereals, nuts.

Deficiency:

It occurs in intestinal malabsorption.

Deficiency result in decreased proprioceptive and vibratory sensation due to posterior column degeneration, areflexia, gaze paraesis, and gait disturbance.

It produces haemolytic anaemia and retrolental fibroplasia in premature infants.

Vitamin E excess:

Headache, malaise, and hypertension

In premature infants parenteral vitamin E therapy may result in ascites, hepatosplenomegaly, cholestatic jaundice, azotaemia and thrombocytopenia.

In patients on oral anticoagulants vitamin E excess can antagonize vitamin K and prolong prothrombin time and potentiate the action of anticoagulants.

Vitamin K

Vitamin K₁ is present in green leafy vegetables and vitamin K₂, which is synthesised by intestinal bacteria. It is a coagulant vitamin required for synthesis of unusual amino acid - gamma carboxyglutamic acid (Gla) which is essential for the production of four coagulation factors—II, VII, IX, and X.

Daily requirement:

80 microgram/day

Sources:

Leafy vegetables and liver

Deficiency:

- Newborn—haemorrhagic disease of the newborn is due to:
 - Defective transfer of vitamin K from mother to foetus
 - Lack of bacteria in the intestine
 - Breast milk contain little of the vitamin
- Obstructive jaundice—defective absorption of vitamin K due to lack of bile. It may result in bleeding during biliary surgery.
- Anticoagulant therapy—Warfarin, etc. act by antagonizing vitamin K.
- Prolonged antibiotic therapy—by eliminating bacteria from the gut—reduced synthesis of vitamin K.



Management

When prothrombin time is prolonged, give vitamin K 10 mg IM for 3 to 5 days till prothrombin time is normal.



Vitamin K Excess

It blocks the effects of oral anticoagulants.

In pregnant women, it can cause jaundice in the newborn.

Water-soluble Vitamins

Thiamine (Vitamin B₁)

Thiamine functions as the co-enzyme, thiamine pyrophosphate. It plays a major role in Krebs's cycle. In the absence of vitamin B₁, cells cannot metabolise glucose aerobically.

Brain is totally dependent on glucose for energy and so nervous system is affected early in thiamine deficiency.

The total body content is 30 mg. It is essential for the metabolism of carbohydrates and in its absence pyruvic and lactic acids accumulate, which produces vasodilatation and increase in cardiac output.

Daily requirement:

1 to 2 mg/day

Dietary sources:

Outer layer of cereals like rice, wheat, millets, pulses, nuts, yeast.

Causes of deficiency:

1. Defective absorption—alcoholism, folate deficiency, chronic malnutrition
2. Excess loss—diarrhoea, diuretic therapy, peritoneal dialysis, haemodialysis
3. Increased requirement—pregnancy, lactation, thyrotoxicosis, prolonged fever.

Benfothiamine (S-Benzoyl thiamine-0-monophosphate): It is a fat-soluble derivative of thiamine. It prevents the formation of advanced glycation end products in diabetes mellitus. It is particularly useful in diabetic neuropathy and retinopathy.



Clinical Features

It causes either cardiac involvement (Wet beriberi) or nervous system involvement (Dry beriberi).

Cardiac Manifestations

They are due to:

1. High output state due to peripheral vasodilatation
 2. Oedema due to retention of sodium and water
 3. Biventricular failure
- Prominent signs are—raised jugular venous pulse, tachycardia, cyanosis, cardiomegaly, hepatomegaly, oedema, etc.

Neurological Manifestations

1. Peripheral neuropathy—distal, symmetrical impairment of sensory, motor, and reflex function.
2. Wernicke's encephalopathy— (cerebral beriberi)— Global confusion, vomiting, nystagmus, ophthalmoplegia, fever, ataxia, coma.
3. Korsakoff's syndrome—impaired ability to learn, retrograde amnesia, confabulation (amnestic—confabulatory syndrome).



Investigations

Low blood thiamine level, raised pyruvate and lactate levels. Low blood or erythrocyte transketolase activity, which increases by more than 15% after administration of thiamine, is diagnostic.



Management

Dramatic improvement in 48 hours in cardiac type of beriberi and the recovery is slow in neurological beriberi.

The memory disorder takes longer time to improve and certain degree of memory impairment may persist.

Thiamine 50 mg IM/IV for 1 to 2 weeks followed by oral therapy.

Riboflavin (Vitamin B₂)

It is in the form of co-enzymes and takes part in various oxidation-reduction reactions.

Daily requirement:

1 to 2 mg/day.

Dietary sources:

Milk, cheese, butter, liver, kidney, meat, whole cereals, legumes and green leafy vegetables.

Causes of deficiency:

Malnutrition, malabsorption and dialysis.

Clinical manifestations:

Sore throat, glossitis, angular stomatitis, cheilosis, seborrhoeic dermatitis, normochromic anaemia.



Management

Tablet riboflavin 5 mg tid.

Niacin (Nicotinic Acid and Nicotinamide)

Limited amount is synthesised in the body from the essential amino acid—tryptophan (60 mg of tryptophan yields 1 mg of nicotinamide).

Daily requirement:
15 to 20 mg/day.

Dietary sources:
Whole cereals, pulses, nuts, meat, fish, liver, kidney yeast and coffee.

Causes of deficiency:

1. Chronic small intestinal disorders
2. Alcoholics
3. Food habit—high intake of maize or millet (sorghum, jowar).

Pellagra

Chronic wasting disease with signs of dementia, diarrhoea and dermatitis.

Skin changes—Erythema, vesiculation, cracking, exudation, crusting with ulceration.

Dermatitis is bilateral, symmetrical, in the form of hyperkeratosis, hyperpigmentation, and desquamation mostly on exposed parts of the body to sunlight and is due to photosensitivity (Dermatitis in the neck—Casal's collar).

Diarrhoea—Widespread involvement of mucosa—glossitis, stomatitis, achlorhydria.

Dementia—Fatigue, insomnia, apathy, confusion, disorientation, hallucination, loss of memory and organic psychosis.

Other signs—Tachycardia, cyanosis, cardiomegaly, hepatomegaly, oedema, etc.



Management

Nicotinamide 100 mg tid PO or 100 mg IM/IV for 2 weeks followed by niacin 10 mg od.

Niacin Excess

Large doses once used for treatment of hypercholesterolaemia, etc. induce release of histamine resulting in severe flushing, pruritus, gastrointestinal disturbances, and hepatic toxicity with cholestatic jaundice, acanthosis nigricans. Asthma can be precipitated.

Pyridoxine (Vitamin B₆)

It is available in three forms—Pyridoxine, pyridoxal phosphates, and pyridoxamine. It acts as a co-factor for many enzymes. Required for protein and fat metabolism.

It is required for synthesis of haem precursors and for synthesis of GABA in brain—gamma amino butyric acid—a neuronal inhibitor and prevents convulsions.

Daily requirement:
1 to 2 mg/day.

Dietary sources:
Whole grain cereals, vegetables, yeast, meat, liver.

Deficiency:

Deficiency is rare. Many drugs act as pyridoxine antagonists and cause deficiency, e.g. INH, cycloserine, penicillamine, hydralazine, oral contraceptive pills.



Clinical Features

Glossitis, angular stomatitis, cheilosis, and neuropathy.

In certain genetic disorders, pyridoxine metabolism is abnormal, and in those infants pyridoxine deficiency causes convulsions and later sideroblastic anaemia.



Management

Many drug-induced antagonism of pyridoxine can be prevented by 30 mg of pyridoxine supplementation/day. However, high doses 100 mg/day is required in penicillamine therapy.

Pyridoxine Excess

Perioral numbness, peripheral neuropathy, ataxia, clumsiness of hands and feet.

Pyridoxine can antagonize levodopa, phenytoin, and barbiturates.

Biotin

It functions as a co-factor in carboxylases.

Daily requirement:
50 to 100 microgram/day.

Causes of deficiency:

1. Prolonged consumption raw egg whites—which binds biotin and prevents absorption from the gut.
2. Prolonged parenteral nutrition.
3. Biotinidase deficiency.



Clinical Features

Perioral dermatitis, conjunctivitis, alopecia, ataxia, paraesthesias, seborrhoeic dermatitis, developmental delay.



Management

Biotin 100 microgram/day



Vitamin B₁₂ and Folate

The metabolism of these vitamins is dealt with in detail in the chapter on haematology.

Vitamin B₁₂

Salient Features:

- Daily requirement is 1 microgram
- It is present only in animal products
- Milk is the only source for vegetarians
- Vegans are at risk of deficiency
- The store of B₁₂ in liver can last for five years
- Vitamin B₁₂ deficiency causes megaloblastic anaemia and neurological degeneration
- It is required for the integrity of myelin
- Deficiency causes uneven demyelination
- It causes peripheral neuropathy, sub-acute combined degeneration of the spinal cord, optic atrophy and cerebral manifestations in the form of dementia.

Folic Acid

Folic acid is very essential to prevent neural tube defects, which develops during the first four weeks after conception.

Imperfect closure of neural tube results in three major congenital defects—

1. Spina bifida
2. Anencephaly
3. Encephalocele.

Folate is directly involved in DNA and RNA synthesis.

Women planning pregnancy and throughout pregnancy should consume diet rich in folate.

Folic acid 5 mg/day should be given during pregnancy.

Vitamin C (Ascorbic Acid)

Most animals can synthesise ascorbic acid from glucose but humans cannot.

Only L-ascorbic acid and dehydro-ascorbic acid have anti-scorbutic activity.

The D-ascorbic acid and other analogues have no anti-scorbutic activity.

Functions of Vitamin C

By hydroxylation of proline to hydroxyproline:

1. It promotes collagen formation. It aids in the production of supporting tissues of mesenchyma

such as osteoid, dentine, collagen, and intercellular cement substance of capillaries.

2. It enhances the iron absorption from the intestine.
3. Vitamin C helps in the synthesis of bile acids from cholesterol.
4. It enhances the functions of reticuloendothelial system.

Phagocytic action of leucocytes and the formation of antibodies have been improved by vitamin C.

5. It helps in hydroxylation of tryptophan to serotonin.
6. By stimulating the growth of intestinal flora, it augments the synthesis of vitamin B complex.
7. Formation of nitroso-amines (powerful carcinogens) is prevented.

As an antioxidant it reduces the risk for cancer formation.

Antioxidant vitamins are vitamins A, C and E.

8. Vitamin C is concentrated in adrenal cortex (160 mg/100 gm tissue) and in the lens of the eyes. It has some role in adrenal steroidogenesis and in preventing cataract formation.
9. It reduces folic acid to tetrahydrofolic acid (THFA). In combination with folic acid, it helps in the maturation of RBC.

Sources

Indian gooseberry (700 mg/100 g), guava (300 mg/100 g) green leafy vegetables, potatoes, meat (kidney, liver) fish, fruits. Partial loss of vitamin C in fruits and vegetables when stored unprocessed.

It is partially preserved by processing (boiling, freezing, steaming, pressure-cooking and canning).

Requirement

50 to 100 mg/day



Causes of Deficiency

Poverty, famine, malnutrition, elderly living alone
Increased demand—pregnancy, lactation, thyrotoxicosis
Decreased absorption—malabsorption syndromes.



Clinical Features

Vitamin C deficiency results in scurvy.

Scurvy

This disease is caused by vitamin C deficiency.

It occurs in areas of urban poverty.

Infancy and Childhood

- Painful swelling over the long bones due to subperiosteal haemorrhage
- Gingivitis, swollen, spongy gums if teeth have erupted
- Easy bleeding from scurvy buds, i.e. papillae in between the teeth
- Finally, the teeth are lost
- Lassitude, anorexia and pain in limbs
- Epiphyseal separation is common
- Inward sinking of sternum with sharp elevation of costochondral junctions (scorbutic rosary)
- Purpura and echymoses may appear in the skin
- Painful joint swelling due to haemorrhage into the joint cavities.

Common sites of haemorrhages: Retrobulbar, subarachnoid and intracerebral.

Normocytic normochromic anaemia is common.

Adults

- Total body content of vitamin C is 1.5 gm
- Gum involvement occurs only in people with teeth
- Swollen, spongy gums with increased friability, bleeding, secondary infection and loosening of the teeth
- Perifollicular hyperkeratosis with haemorrhage
- Haemorrhage into the muscles of the arms and legs
- Haemorrhage into the joints and in the nail-beds
- Petechial haemorrhages in the viscera and echymoses
- Delayed wound healing
- Other clinical manifestations are icterus, oedema, fever, convulsions and hypotension
- Vitamin C deficiency causes normochromic normocytic anaemia
- Associated nutritional folate deficiency can result in macrocytic/megaloblastic anaemia.



Investigations

1. Low ascorbic acid level in platelets and plasma.
2. Elevated serum bilirubin value.
3. Abnormal capillary fragility.
4. Classical X-ray changes of bones.



Management

Scurvy is potentially fatal.

100 mg of vitamin C tid until a total dose of 4 gm has been administered and then followed by 100 mg od.

Hypervitaminosis C

Large doses interfere with the absorption of B₁₂ resulting in anaemia.

Large amount of iron may be absorbed leading to haemochromatosis.

Excess amount of oxalate crystals is passed in the urine, which may precipitate oxalate stone formation.

Inorganic Nutrients

Fourteen minerals are essential for life. They are sodium, potassium, calcium, magnesium, iron, iodine, copper, zinc, cobalt, phosphorus, sulphur, chromium, selenium, and fluorine.

Sodium

It is the main electrolyte in extracellular fluid (Plasma and interstitial fluid). Along with chlorides, it determines osmolality of extracellular fluid.

Source

Common salt—sodium chloride, small amounts in milk and vegetables.

Requirement

1 to 2 gm/day but average intake by Indians—10 to 12 gm/day.

Hyponatraemia

Serum sodium level less than 130 mEq/L.



Causes

- Extrarenal losses—vomiting, diarrhoea, sweating, pancreatitis, burns, peritonitis
- Renal losses—Diuretics, salt losing nephropathy, ARF, CRF, Renal injury, renal tubular acidosis
- Dilutional hyponatremia—increase in total body water content—nephrosis, cirrhosis and CCF
- SIADH—syndrome of inappropriate ADH secretion
- Addison's disease
- Hypothyroidism.



Clinical Features

Confusion, anorexia, lethargy, cramps dehydration. When the sodium level falls below 120 mEq/L: seizures, hemiparesis, and coma.



Management

- Hypovolemic patients—normal saline
- Dilutional hyponatremia—water restriction
- SIADH—Water restriction + demeclocycline.
- Serum level below 120 mEq/L—Hypertonic saline infusion.

Hypernatraemia

When the serum sodium is elevated above 150 mEq/L.



Causes

1. Primary aldosteronism
2. Cushing's syndrome
3. Congenital adrenal hyperplasia
4. Hypertonic saline infusion
5. Hypertonic haemodialysis/peritoneal dialysis
6. Haemoconcentration due to excessive fluid loss—vomiting, diarrhoea, diuretics, etc.
7. Diabetes insipidus (central type and nephrogenic).



Clinical Features

Altered mental status, twitching, seizures and coma. When serum level exceeds 160 mEq/L—it dehydrates cerebral vessels and causes ruptures of cerebral vessels—leading to permanent neurological deficit.



Management

Hypovolemic hypernatremia (haemoconcentration)
— Normal saline followed by 0.45% saline
Hypervolemic hypernatremia
— Loop diuretics, hypotonic fluids or dialysis
Central diabetes insipidus
— Desmopressin

Potassium

Potassium is mainly present in the intracellular compartment. Oral intake and renal excretion maintain the extracellular potassium balance. Acidosis shifts potassium out of cells and alkalosis shifts potassium into the cell.

It maintains the intracellular osmotic pressure. Extracellular potassium level plays a major role in skeletal and cardiac muscle activities.

Normal serum value: 3.5 to 4.5 mEq/L.

Sources

Banana, orange, lime, apple, pineapple, almond, beans, dates, yam, potato, and tender coconut water. It maintains the intracellular osmotic pressure. Extracellular potassium level plays a major role in skeletal and cardiac muscle activities.

Daily Requirement

3 to 4 gm/day.

Hypokalaemia

When the serum level falls below 3.5 mEq/L.



Causes

1. GIT—loss due to vomiting diarrhoea, fistulae
2. Renal—diuretics, metabolic alkalosis, renal tubular acidosis
3. Primary aldosteronism
4. Cushing's syndrome
5. Drugs—insulin and glucocorticoids.



Clinical Features

- Muscle weakness, ileus, and polyuria.
- ECG—'U' wave, prolonged Q-T interval, flat or inverted.
- T-wave and premature beats. Hypokalaemia predisposes to digitalis toxicity.
- In severe hypokalaemia—flaccid paralysis and cardiac arrest.



Management

1. Potassium rich dietary supplements or potassium chloride in liquid form.
2. In severe hypokalaemia—KCl 20 to 40 mEq/hour IV with cardiac monitoring.

Hyperkalaemia

When the serum level exceeds 5.5 mEq/L.



Causes

1. Acute and chronic renal failure
2. Addison's disease
3. Hypoaldosteronism
4. Shift of potassium from tissues—Acidosis, crush injuries, internal bleeding, blood transfusion.

5. Drugs—Potassium sparing diuretics, ACE inhibitors
6. Pseudohyperkalaemia—due to increased cell destruction—haemolysis, thrombocytosis, and leukocytosis.



Clinical Features

Conduction disturbances and various arrhythmias.
ECG—Peaked T-waves in pre-cordial leads-absent P-wave and wide QRS.



Management

1. Furosemide 40 mg IV
2. Calcium gluconate 10 ml 10% IV
3. Insulin + glucose to shift the potassium into the cells.
4. NaHCO₃ to correct acidosis.
5. Haemodialysis.

Calcium

The total calcium in human body is 1 to 1.5 kg, of which 99% is in bone and 1% is in extracellular fluid. The major quantum of calcium is used in the formation of bone and teeth. Calcium is essential for transmission of nerve impulses and muscle contraction. It serves as intracellular messenger of different hormones. It takes part in blood coagulation.

Normal serum value: 9 to 11 mg/dl.

Daily Requirements

- Adults—500 mg
- Pregnant and lactating women—1200 mg
- Post-menopausal women—1200 to 1500 mg.

Dietary Sources

Milk, cheese, yogurt, eggs, fish eaten with bone, almonds and peanuts, leafy vegetables and dried fruits. 100 cc of milk contains 100 mg of calcium.

Calcium is absorbed actively from jejunum and passively from ileum. Acidic pH, vitamin D, and presence of protein enhances absorption of calcium. Eighty per cent of calcium taken is lost in stool and some amount is also lost in the urine, and that is the cause for negative balance when the calcium is consumed in small quantum. The metabolism of calcium is intimately related to vitamin D, parathyroid hormone and calcitonin.

Phosphorus

Total body phosphorus is about 1 gm. Similar to calcium 80% is present in bone and teeth and 10% in muscles. It plays a major role in the formation of bone, teeth, production of energy phosphate compounds such as ATP, CTP, GTP, DNA and RNA synthesis and acts as buffer system in blood.

Normal serum level: 3 to 4 mg/dl.

Dietary Sources

Milk, cheese, eggs, cereals, meat.

Eighty percent of ingested phosphorus is absorbed in jejunum and the serum level is controlled by the excretory function of the kidney. Fifteen percent is excreted in the urine and the remaining 85% are reabsorbed in the proximal tubule and so its level goes up in renal failure. Antacid aluminium hydroxide prevents its absorption.

Hypophosphataemia

It occurs in hyperparathyroidism and rickets.

It causes muscle weakness, anorexia, malaise and bone pains. Dietary deficiency is rare and hypophosphataemia does not produce any adverse symptoms. However, in the presence of hypercalcaemia, hyperphosphataemia can lead to metastatic calcification.

Iron

The total body iron content is 4 gm. Sixty per cent of that is present in haemoglobin. It is used in erythropoiesis.

Normal serum level: 80 to 120 µgm/dl.

Daily Requirement

- For Males—1 mg
- For Females—2 mg
- Pregnant/lactating women—3 mg.
- Only 10% of consumed iron are absorbed in duodenum and upper jejunum and so, the daily intake has to be 10, 20 and 30 mg respectively for the above categories.

Dietary Sources

Green leafy vegetables, fruits, onions, cereals, pulses, jaggery, grapes, dates, animal foods like meat, liver, fish, kidney, egg yolk. Food rich in vitamin C enhances absorption of iron.



Iron Deficiency

Iron deficiency causes microcytic hypochromic anaemia.

Iron Excess

Siderosis denotes excessive deposition of iron in various sites like liver, pancreas leading to cirrhosis, DM.

Iodine

It is required for the synthesis of thyroid hormones. Total body iodine content is 30 mg and 80% of it is in thyroid.

Normal serum level: 5 to 10 µg/dl.

Daily Requirement

150 to 200 µg/day.

Dietary Source

Seawater, salt, sea-fish, vegetables and milk. Iodine deficiency is common in mountainous terrains such as Alps and Himalayas—endemic thyroid goitres are common.

Prevention

Fortification of common salt with potassium iodide. Iodized poppy seed oil 1 to 2 ml IM injection will protect the individual against iodine deficiency for 5 years.

Zinc

It acts as a co-factor for a number of enzymes. It improves appetite, wound healing, and sense of well-being. Zinc deficiency causes thymic atrophy. Insulin in the stored form in beta cells of pancreas contains zinc but not when released.

Normal serum value: 100 µg/dl.

Daily Requirement

5 to 10 mg/day.

Dietary Sources

Grains, beans, nuts, cheese, meat and shellfish. Plasma zinc is lowered in acute myocardial infarction, infections, and malignancies. Patients on prolonged IV alimentation (zinc free) may develop acute zinc deficiency leading to diarrhoea, mental apathy, and eczema around mouth and loss of hair (Fig. 2.8).

Chronic zinc deficiency leads to dwarfism and hypogonadism and ophthalmoplegia. Secondary zinc deficiency is seen in alcoholism and poorly controlled diabetes mellitus.



Fig. 2.8: Acrodermatitis enteropathica (zinc deficiency)

Fluorine

It plays a major role in the prevention of dental caries. The safe limit of fluorine is 1 part per million in water (1 PPM).

Source

Soft water contains no fluoride. Hard water contains fluoride and sometimes to the tune of toxic level—10 PPM. Sea-fish and tea when taken frequently can contribute as much as 3 mg/day. Fluoride level more than 2 PPM can cause loss of appetite, AGE, and loss of weight.

Fluoride level more than 5 PPM causes mottling of enamel and discolouration of teeth.

Fluoride level more than 10 PPM causes osteosclerosis, increase in bone density and calcification of ligaments (Fluorosis in certain endemic areas).

Prevention of Caries

When fluorine level is low, addition of traces of fluoride—1 PPM to the public waters supplies.

Magnesium

Total body magnesium is 20 gm and 75% of it is complexed with calcium in bone.

Normal serum level: 2 to 3 mg/dl.

Daily Requirement

300 mg/day.

Sources

Cereals, beans, leafy vegetables and fish.

It is an activator of many enzymes and deficiency causes neuromuscular irritability, tremors and carpopedal spasm. Chronic diarrhoea, chronic alcoholism and cirrhosis cause deficiency. Increased magnesium level causes renal damage.

Manganese

Total body content is 15 mg and maximum quantum is in liver. It is an activator of many enzymes, stimulates bone growth and cholesterol synthesis and also takes part in glucose metabolism.

Source

Nuts and tea-leaves.

Daily Requirement

5 mg/day.

Copper

Total body copper is 100 mg and it is present in muscles, bone, liver, kidney, brain, heart and hair. It is present in many enzymes including cytochrome oxidase and ceruloplasmin.

Normal serum value: Ceruloplasmin 25 to 50 mg/dl and its equivalent amount of copper is 3 to 5 µgm.

Daily Requirement

2 to 3 mg/day

Source

Dairy products, cereals, meat, and nuts. Copper containing ceruloplasmin helps in iron transport and in the formation of haemoglobin.

Copper deficiency causes iron deficiency anaemia and low ceruloplasmin causes Wilson's hepatolenticular degeneration due to copper deposition.

Cobalt

Vitamin B₁₂ contains cobalt. Cobalt stimulates production of erythropoietin.

Nickel

It is present in certain enzymes like arginase and carboxylases. Nickel content of the hair—male 1 PPM and female 4 PPM. Some chocolate preparations contain nickel.

Chromium

Total body content of chromium is 6 mg and this level decreases with age. Cooking in stainless steel containers improves the chromium of food.

Chromium deficiency causes glucose intolerance. Chromium improves receptor binding of insulin.

Tobacco contains large amount of chromium and the carcinogenic effect of tobacco is linked to chromium. (bronchogenic carcinoma).

Selenium

By its intracellular antioxidant effect, it protects tissues and cell membrane against peroxidation and because of this property, it is considered to have anticancer activity (? human cancer). Selenium deficiency causes cardiomyopathy, and myopathy.

Selenium excess causes alopecia, abnormal nails, emotional lability, and lassitude and garlic odour to breathe.

Dietary Modifications—Diet Therapy

Type of diet	Disorders
Low protein	Chronic renal failure, nephrotic syndrome, hepatic encephalopathy
High carbohydrate	70% of kcal—Athletes
Low simple sugar	Post-gastrectomy state, lactose intolerance
Low energy	Obesity, hypertension
High energy	Undernourished
Small feedings	Gastroesophageal reflux
Low fat	Steatorrhoea, gastroesophageal reflux, acute hepatic, gallbladder or pancreatic disorders, colon, prostate and breast cancers
Low fat and low cholesterol	Hyperlipidaemia and coronary heart disease
High fibre	Hyperlipidaemia, diabetes mellitus
Low fibre	Crohn's disease, regional enteritis, ulcerative colitis.
Low sodium	Hypertension, congestive cardiac failure ascites, chronic renal failure
Low potassium	Chronic renal failure, hyperkalaemia
High potassium	Diuretic therapy, hypokalaemia
High calcium	Osteoporosis
Low phosphorus	Renal failure
Low oxalate	Renal stones
Gluten free	Coeliac disease



Vitamins and Trace Minerals – Requirement/day – Deficiency-induced Disorders

<i>Nutrient</i>	<i>Intake/day</i>	<i>Deficiency-induced disorders</i>	<i>Evaluation</i>
Vitamin A (Retinol)	5000 IU	Xerophthalmia, Bitot's spots, Night blindness, Keratomalacia, Follicular hyperkeratosis, Immune dysfunction, Impaired embryonic development	Serum retinol
Vitamin B ₁ (Thiamine)	1-2 mg	Peripheral neuropathy, Beriberi, Cardiomegaly with or without failure, Fatigue, Ophthalmoplegia, Wernicke's encephalopathy	RBC transketolase activity
Vitamin B ₂ (Riboflavin)	1-2 mg	Angular stomatitis, Sore tongue and mouth (Magenta tongue), Cheilosis, Seborrhoeic dermatitis, Eye irritation	RBC glutathione reductase activity
Vitamin B ₃ (Niacin)	15-20 mg	Pellagra (dermatitis, diarrhoea, dementia), Sore mouth and tongue	Urinary N-methyl-nicotinamide
Vitamin B ₅ (Pantothenic acid)	5-10 mg	Weakness, Fatigue, Paraesthesias, Tenderness of heels and feet	Urinary pantothenic acid
Vitamin B ₆ (Pyridoxine)	12 mg	Cheilosis, Glossitis, Seborrhoeic dermatitis, Peripheral neuropathy, Convulsions, Hypochromic anaemia	Plasma pyridoxalphosphate
Vitamin B ₇ (Biotin)	100-200 µg	Alopecia, Seborrhoeic dermatitis, Myalgia, Seizures, Hyperesthesia	Plasma biotin
Vitamin B ₉ (Folic acid)	400 µg	Megaloblastic anaemia, Glossitis, Diarrhoea, Increased homocysteine	Serum folic acid RBC folic acid
Vitamin B ₁₂ (Cobalamin)	5 µg	Megaloblastic anaemia, Decreased vibratory and position sense, Ataxia, Paraesthesias, Dementia, Diarrhoea	Serum cobalamin, Serum methylmalonic acid
Vitamin C (Ascorbic acid)	100 mg	Gingival inflammation and bleeding, Purpura, Petechiae, Ecchymosis, Scurvy, Weakness, Depression, Joint effusion, Poor wound healing	Plasma ascorbic acid, Leukocyte ascorbic acid
Vitamin D (Ergocalciferol)	400 IU	Rickets-Skeletal deformity-Rachitic rosary, Bowed legs, Osteomalacia, Osteoporosis, Bone pain, Muscle weakness, Tetany	Serum 25 hydroxy-Vitamin D
Vitamin E (Alpha tocopherol)	10-15 IU	Neuropathy, Abnormal clotting, Retinopathy, Haemolysis, Spino-cerebellar ataxia	Serum tocopherol, Total lipid-TGL:TC
Vitamin K (Phylloquinone)	80 µg	Easy bruising/Bleeding	Prothrombin time
Chromium	30-200 µg	Glucose intolerance, Peripheral neuropathy, Encephalopathy	Serum chromium
Zinc	15 mg	Impaired taste and smell, Alopecia, Dermatitis (Acro-orificial lesion) Hypogonadism, Delayed sexual maturation, Growth retardation, Dementia	Plasma zinc
Copper	2 mg	Anaemia, Neutropenia, Osteoporosis, Defective keratinisation and pigmentation of hair	Serum copper Plasma ceruloplasmin
Manganese	1.5 mg	Dementia, Dermatitis, Hypercholesterolaemia, Impaired growth and skeletal development	Serum manganese
Selenium	100-200 µg	Cardiomyopathy, Muscle weakness	Serum selenium, Blood glutathione – Peroxidase activity
Iodine	150 µg	Hypothyroidism, Goitre	TSH, Urine iodine
Iron	10-15 mg	Hypochromic microcytic anaemia, Impaired congenital development, Pre-mature labor, Increased peri-natal and maternal mortality	Serum Iron, Total iron binding capacity, Serum ferritin
Molybdenum		Severe neurological abnormalities	

Obesity

As per the state of nutrition, the individuals can be classified as normal, overweight and underweight.

The state of nutrition can be assessed in the following ways:

- Ideal body weight (IBW): $IBW = 22.5 \times (\text{height in metres})^2$
 - Overweight - More than 10% of IBW
 - Underweight - Less than 20% of IBW
 - Obesity - More than 20% of IBW
- Body mass index: $BMI = \text{Weight in kg}/(\text{height in metres})^2$
 - BMI
 - In Males—20 to 25
 - In Females—18 to 23
 - Overweight - BMI is between 25 to 30
 - Underweight - For Males—BMI below 18
For Females—BMI below 16
 - Obesity - BMI is more than 30

Grading of obesity:

Grade I: BMI—25 to 30 (overweight)

Grade II: BMI—30 to 40 (obese)

Grade III: BMI—more than 40 (gross obesity)

- Skin-fold thickness:

It can be estimated by using special pair of calipers over the triceps, biceps, subscapular and supriliac region.

Normal triceps skin-fold thickness:

Adult males—12.5 mm

Adult females—16.5 mm

- Rough calculation of body weight in an adult (Broca's index):

Height in inches = weight in kg

Height in cm - 100 = desired body weight in kg.

- Waist-hip ratio:

Waist-hip ratio is useful to assess the prognosis in a case of obesity.

Waist-measurement of narrowest segment between ribcage and iliac crest

Hip-maximal measurement of the hip over the buttocks:

Waist-hip ratio	Type of obesity	Prognosis
0.8 or less	Pear-shaped obesity	Good
0.9 or more	Apple-shaped obesity	Increased morbidity.

Apple-shaped obesity is nothing but abdominal obesity, which is associated with hyperlipidaemia, insulin resistance, diabetes mellitus and coronary artery disease.

- Waist circumference

Waist circumference alone is enough to assess the prognosis in obesity.

Waist Circumference—Morbidity Risk

Sex	Moderate	High
Male	More than 94 cm (37")	More than 102 cm (40")
Female	More than 80 cm (32")	More than 88 cm (35")

Type of Obesity

- Generalised obesity—Uniform deposition of excess fat throughout the body
- Android obesity—Excess deposition of fat over the waist.
- Gynoid obesity—Excess deposition of fat over the hips and thighs.
- Superior or central type of obesity—Excess deposition of fat over the face, neck, and upper part of the trunk and the limbs are thin—Cushing's syndrome.

Aetiology

- Excess energy intake
 - With excess feeding, excess calories are stored in adipose tissue.
- Decreased energy expenditure
 - Physical activity is less in the obese than in the lean.
- Behavioural changes
 - High fat intake results in obesity.
 - High fat diets do not switch-off appetite.
 - Little is used for energy expenditure and is mostly stored.
 - Frequent snacks in between standard meals.
 - Consumption of energy dense foods—sweets, ice-cream, soft-drinks
 - Alcohol—It provides energy and stimulates appetite.
 - Smoking—Energy expenditure is more in smokers and their appetite is lost. Most of the smokers are lean. Giving up smoking induces fall in expenditure and increases food intake.
- Age
 - Physical activity is decreased with aging.
- Familial and genetic factors
 - They play a major role.
 - More than 20 genes and 12 chromosomes have been implicated in obesity.
 - Lipoprotein lipase—This enzyme is synthesised in adipocytes. It induces obesity by causing deposition of fat calories in adipose tissue.



- B. Leptin—This hormone is produced by adipose tissue. It acts at the level of hypothalamus to suppress appetite. Elevated levels of leptin are seen in obesity similar to elevated insulin levels in type 2 diabetes mellitus obese. Exact role of leptin in obesity is not known.
- 6. *Secondary obesity due to endocrine causes*
 - A. Hypothalamic disorders—Froehlich’s syndrome Laurence-Moon-Biedl syndrome—Obesity, hypogonadism, over eating, visual impairment due to retinitis pigmentosa, etc.
 - B. Hypothyroidism—Decreased metabolic rate with obesity.
 - C. Cushing’s disease—Moon facies with central obesity.
 - D. Insulinoma—Some of them are obese. It is due to increased calorie intake secondary to recurrent hypoglycaemia.

Pathology

In obesity, the adipocytes number and size are increased in middle age resulting in obesity. With excess calorie intake the number and size can increase at any age. However, weight reduction causes reduction in size of adipocytes and the number does not decrease.

Fat is deposited throughout the body, around internal organs, omentum, and in the intramuscular spaces. There is expansion of lean body mass with increased size of kidneys, heart, liver and skeletal muscles. There is fatty infiltration of liver.

Drugs

Drugs can cause increase in body weight, e.g. corticosteroids, tricyclic antidepressants, valproate, sulphonylureas, contraceptives.



Complications

1. Hyperlipidaemias
2. Hypertension
3. Diabetes mellitus type 2
4. Insulin resistance
5. Atherosclerosis
6. Coronary artery disease
7. Cerebrovascular strokes due to hypertension
8. Osteoarthritis of knees, hip, foot, and spine
9. Varicose veins, deep vein thrombosis, pulmonary embolism
10. Gallstones
11. Ventral and hiatal hernias

Syndromes of Obesity with Hypogonadism and Mental Retardation

Feature	Prader-Willi	Laurence-Moon-Biedl	Ahlstrom	Cohen	Carpenter
Inheritance	Sporadic	Autosomal-recessive	Autosomal-recessive	Autosomal-recessive	Autosomal recessive
Stature	Short	Normal/rarely short	Normal/rarely short	Short/tall	Normal
Obesity Onset	Generalised Early 1-2 years	Generalised Early 1-2 years	Truncal Early 1-2 years	Truncal 5 years	Truncal and gluteal
Craniofacies	Narrow bi-frontal diameter, Almond shaped eyes, V-shaped mouth, high- arched palate	No typical features	No typical features	High nasal bridge, high-arched palate Open mouth, Short-philtrum	Acrocephaly flat nasal bridge, High-arched palate
Limbs	Small hands and feet, hypotonia	Polydactyly	Normal	Narrow hands and feet, hypotonia	Polydactyly Syndactyly, genu valgum
Gonads	Hypogonadism	Hypogonadism	Hypogonadism Not in females	Normal/ hypogonadism	Hypogonadism
Other features	Enamel hypoplasia, nasal speech, hyperphagia			Dysplastic ears Delayed puberty	
Mentation	Retardation	Normal	Normal	Retardation	Retardation

12. Hypoventilation syndrome (Pickwickian syndrome)—hypercapnia, hypoxia, cyanosis, polycythaemia, pulmonary hypertension, chronic cor pulmonale.
13. Infertility, hirsutism
14. Pregnancy—neural tube defects, pre-eclampsia, gestational diabetes, pre-term labour, increased perinatal mortality.
15. Cancers—gallbladder, colon, prostate
In post-menopausal women—breast, ovary, endometrium
16. Adrenal function—plasma cortisol levels are increased.
17. Psychological—depression
18. Skin—abnormal skin folds—fungal and bacterial infections—Striae formation—chafing of skin of the thighs and axillae.

Prognosis

Mortality rate is 25% higher if a person is 25% over weight and 50% higher if the person is 40% overweight.

Sustained 10 Kg reduction of weight in obese—Benefits:

- It causes a fall of 10 mm Hg systolic and 20 mm Hg diastolic blood pressure.
- 30% increase in exercise tolerance.
- 30% reduction in DM related mortality.
- Risk of developing DM is 50% less.
- 50% fall in obesity related cancer deaths.
- 10% increase in HDL cholesterol and 10% fall in total cholesterol.
- There is also 15 to 20% fall in LDL and triglycerides.



Management

Diet

Moderate reduction in energy intake—500 to 600 calories less than the energy expenditures of the individual. Fat intake must be reduced. Avoid frequent snacks and diets with concentrated sugars. Complex carbohydrates with enough protein with adequate amount of fibre, vitamins and minerals are advised, e.g. for 1000 kcal diet—complex carbohydrate 100 gm, protein 40 to 50 gm, fat 30 gm. The aim of diet restriction is to reduce weight by 1 kg/week.

Exercise

Brisk walking 40 metres a day or cycling or swimming or games depending upon the individuals choice.

Energy Expenditure during Exercise

Mild exercise

- Sitting 80 kcal/hour
- Standing 120 kcal/hour

Moderate exercise

- Fast walking 3.75 mph—250 kcal/hour
- Swimming—250 kcal/hour
- Tennis—350 kcal/hour

Vigorous exercise

- Cycling 10 mph—600 kcal/hour
- Running 10 mph—800 kcal/hour.

Drug therapy:

There are two types of appetite suppressants

1. Affecting the catecholaminergic pathway:
Amphetamines diethylpropion, phentermine and mazindol

Adverse effects: Cerebral stimulation and insomnia

2. Affecting the hypothalamic serotonergic system:
Fenfluramine and dexfenfluramine

Dose: Fenfluramine—60 to 120 mg/day
Dexfenfluramine—15 mg bid

Adverse effects: Valvular heart disease, arrhythmias, pulmonary hypertension.

Newer Drugs

1. Orlistat—It inhibits pancreatic and gastric lipases leading to reduction in fat absorption
2. Sibutramine—It is a beta 1 adrenoceptor and 5-HT receptor agonist.
It reduces food intake and increases metabolic rate.

Adverse effects—Dry mouth, insomnia, tachycardia, raise of BP.

Drug therapy is indicated when BMI is more than 30 and failure with diet restriction.

Very Low Calorie Diets

Total intake of calories less than 800 kcal/day and total starvation diet are advised only under medical supervision.

Surgery

It is advised only when BMI is more than 40 and failure with strict diet restriction and drug therapy.

1. Vertical banded gastroplasty—to reduce the volume of stomach
2. Gastric bypass



Diagnostic Criteria and Clinical Manifestations

	<i>Anorexia nervosa</i>	<i>Bulimia</i>
Sex	Female	Female
Age incidence	Below 25 years	Young females
Cause of weight loss	Restriction of diet	Vomiting
Binge eating	Uncommon	Common
Appearance	Weight loss more than 25% wasted	Fairly normal
Ritualised exercise	Usual	Rare
Amenorrhoea	100%	50%
CVS: (bradycardia hypotension)	Common	Uncommon
Skin: (hirsutism carotenaemia, dryness)	Common	Uncommon
Hypothermia	Common	Uncommon
Oedema	+/-	+/-
Complications	Hypokalaemia Cardiac arrhythmias	Hypokalaemia Cardiac arrhythmias
Oesophageal/gastric rupture	—	Common

3. Gastric balloon—reduces the volume of stomach
4. Wiring the jaws—allows only fluid diet
5. Intestinal bypass—jejunoileal bypass induces malabsorption.

Anorexia Nervosa and Bulimia

Two important eating disorders seen in young females because of fear of becoming fat. The exact aetiology is not known, and most investigators favour psychiatric aetiology. The syndromes can overlap.

Anorexia Nervosa

Weight loss of 25% or more of original body weight in the absence of organic disease.

Bulimia

Recurrent episodes of binge eating with vomiting and to lose weight they use laxatives, diuretics and do vigorous exercise.

Above two eating disorders are diagnosed only on clinical grounds. No specific diagnostic laboratory tests exist.



Management

There is no specific treatment.

The benefits of psychiatric intervention are marginal. Hospitalise the anorexia nervosa patients and treat symptomatically. Ryle's tube feeding and at times total parenteral nutrition. For bulimia, hospitalisation is not required, except for the management of complications. Advised to consume small quantum of feeds to prevent gastric and oesophageal rupture.

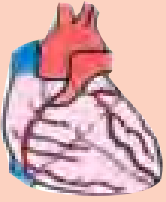

Chapter 3

Cardiovascular System

SYMPTOMS

SIGNS

CHEST PAIN

EXERTIONAL
DYSPNOEA

PAROXYSMAL
NOCTURNAL
DYSPNOEA

ORTHOPNOEA

FATIGUE

PALPITATION

SYNCOPE

HAEMOPTYSIS

Anaemia
Corneal arcus
Xanthelasma
Cyanosis
(Central/Peripheral)
Malar flush
Pyrexia
Coldness of the
extremities
Clubbing
Oedema

Raised JVP
Arterial pulse
Rhythm disorder
Blood pressure

Position of trachea
Precordium
Apical impulse
Parasternal impulse
Palpable heart sounds
Thrills
Heart sounds/gallop
Added sounds
Murmurs
Friction rubs

Crackles/wheezes
over the lung
fields

Tender hepatomegaly
Splenomegaly

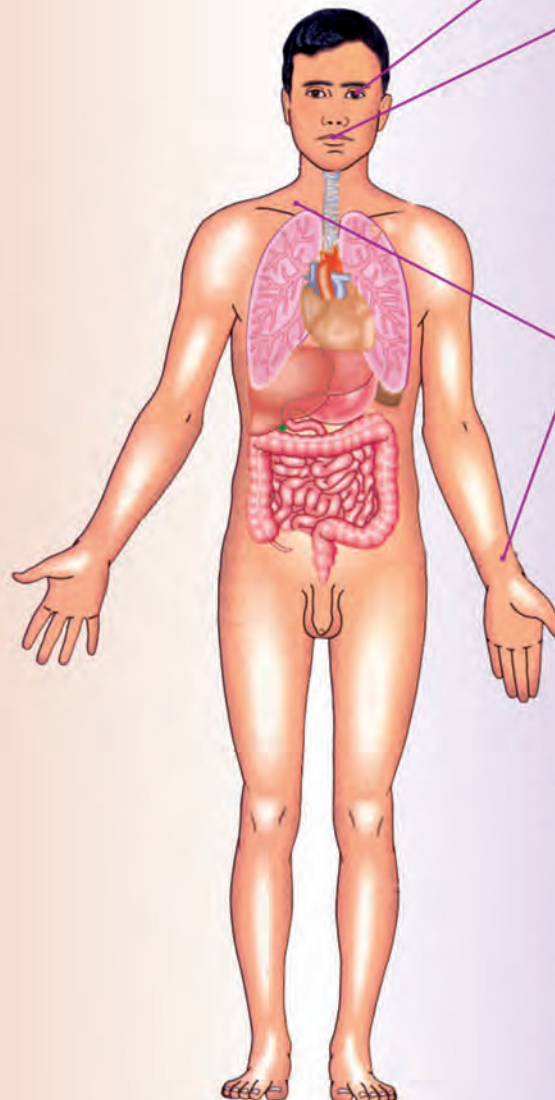



Symptoms and Signs

Dyspnoea

Dyspnoea is defined as an abnormally uncomfortable awareness of breathing.

New York Heart Association

Grading for dyspnoea, palpitation, fatigue and angina in patients with cardiovascular disease.

- Class I No symptoms with ordinary physical activity.
- Class II Symptoms with ordinary activity, slight limitation of physical activity
- Class III Symptoms with less than ordinary activity. Marked limitation of activity
- Class IV Symptoms with any physical activity or even at rest

Note: Patients with major heart disease may have no, or only minor symptoms, while patients with only minor heart disease may have major symptoms.

Normal individuals also develop dyspnoea on severe exertion but the recovery time is short, whereas in patients with heart disease the recovery time is prolonged.



Causes

Cardiac

- a. Left heart failure
- b. Congenital heart diseases (Shunts and valvular lesions)
- c. Acquired valvular heart diseases
- d. Coronary heart disease
- e. Hypertensive heart disease
- f. Cardiomyopathies.

Dyspnoea is the major symptom of left heart failure.

Respiratory

- a. Bronchial asthma
- b. Chronic obstructive lung disease—Chronic bronchitis, emphysema
- c. Chronic restrictive lung disease
 - Parenchymal
 - Pneumoconiosis
 - Interstitial lung disease
 - Extra parenchymal
 - Myasthenia gravis
 - Guillain-Barré syndrome
 - Ankylosing spondylitis
 - Kyphoscoliosis
 - Obesity
- d. Pneumonias

- e. Pulmonary neoplasm
- f. Pulmonary embolism
- g. Laryngeal or tracheal obstruction

Inhalation of toxic gases and fumes.

Haematological: Severe anaemia.

Miscellaneous: Anxiety, hysterical hyperventilation.

Orthopnoea

Dyspnoea that develops in recumbent position and is relieved by sitting up or elevation of the head with pillows. Orthopnoea occurs within 1-2 minutes after assuming recumbency and recovery on sitting up is also immediate.

Mechanism

During the day, gravitational effects on the control of fluid balance may favour a loss of intravascular fluid into the interstitial space. When the patient is in a horizontal position, the oedema fluid may return to the vascular system, augmenting the venous return. The failing left ventricle is not able to cope with extra volume of blood delivered to it, resulting in increase in pulmonary venous and capillary pressure leading to pulmonary interstitial oedema and decreased airway compliance. This factor, along with the elevated diaphragm in the lying posture decrease the vital capacity of the lung. The patient is unable to breathe easily, when lying down and must elevate his or her head on pillows to breathe comfortably.



Causes

Acute left heart failure
Extreme degree of CCF.

Paroxysmal Nocturnal Dyspnoea (PND)

Attacks of dyspnoea which occur at night and awaken the patient from sleep. It occurs 2-5 hours after the onset of sleep and takes 10-30 minutes for recovery after assuming the upright posture.

Mechanism

Mechanism of PND is similar to that of orthopnoea. However, a fall in PaO₂ and a decreased sympathetic support to left ventricular function during sleep also contribute to the development of PND.



Causes

Ischaemic heart disease



Aortic valve disease
Hypertension
Cardiomyopathy
Atrial fibrillation
Rarely in mitral disease or atrial tumours.
PND is the earliest symptom of left heart failure.

Trepopnoea

Dyspnoea occurs only in the left or right lateral decubitus position, most often in patients with heart disease.

Platypnoea

Platypnoea is dyspnoea which occurs only in the upright position.



Causes

- Left atrial thrombus
- Left atrial tumours—myxomas
- Pulmonary arteriovenous fistula.

Angina Pectoris

A discomfort in the chest and adjacent area due to myocardial ischaemia. It is due to a discrepancy between myocardial oxygen demand and supply.

Canadian Heart Association Grading of Angina

- Grade I Angina on severe exertion
Grade II Angina on walking uphill or climbing more than one flight of ordinary stairs
Grade III Angina on walking on level ground or climbing one flight of ordinary stairs
Grade IV Angina at rest.

Differentiation between Cardiac Asthma and Chronic Pulmonary Disease

Features	Left sided failure (cardiac asthma)	Chronic pulmonary disease
Age	Old age	Young and middle age
History	Heart disease	Lung disease
Onset	Acute	Gradual
Symptoms	Dyspnoea precedes cough and expectoration	Cough with expectoration precedes dyspnoea
Pulse	Pulsus alternans	Pulsus paradoxus
Percussion	Dull note due to pulmonary oedema or hydrothorax	Normal or hyper-resonant note
Auscultation	S ₃ over cardiac apex; crackles over both lung bases	Wheeze over both lung fields

Characteristics of Anginal Pain

Site	Substernal
Nature	Pressing, squeezing, strangling, constricting, 'a band across the chest', 'a weight in the centre of the chest'. The patient cannot pinpoint the site of pain.
Radiation	To both the shoulders, epigastrium, back, neck, jaw, teeth. Anginal pain can radiate in all directions, as mentioned above, but more commonly radiates to the left shoulder and ulnar aspect of the left arm.
Duration	5 to 15 minutes
Aggravating factors	Exertion, emotion, after a heavy meal, or exposure to cold
Relieving factors	Rest, nitrates.

Levine Test

Relief of anginal pain by carotid sinus massage.

Anginal Equivalent

Anginal equivalents are symptoms of myocardial ischaemia other than angina such as dyspnoea, faintness, fatigue and eructations. They are precipitated by exertion and relieved by rest and nitrates.

Prinzmetal Angina

Prinzmetal angina is a type of angina pectoris, which typically occurs during rest and may recur in a nightly cyclic pattern. ST-segment elevation or depression on the electrocardiogram and coronary artery spasm have been documented during an attack.

Nocturnal Angina

Angina occurs during sleep at night due to coronary ostial stenosis, as seen in cardiovascular syphilis.

Unstable Angina

The following three patient groups may be said to have unstable angina pectoris.

- Patients with new onset (< 2 months) angina that is severe and/or frequent (>) 3 episodes/d
- Patients with accelerating angina, that is, those with chronic stable angina who develop angina that is distinctly more frequent, severe, prolonged or precipitated by less exertion than previously.
- Those with angina at rest.

When unstable angina is accompanied by objective ECG evidence of transient myocardial ischaemia, it is



associated with critical stenosis in one or more major epicardial coronary arteries in about 85%.

Second Wind Angina

It occurs on initial exertion, but then subsides without the patient resting only to sometimes recur with continuing exertion. It is not uncommon and may cause diagnostic confusion.



Causes of Angina Pectoris

1. *Coronary artery disease*: Due to narrowing or spasm of coronary artery.
2. *Aortic stenosis*: Due to decreased stroke volume, reducing coronary perfusion and compression of coronaries by hypertrophied myocardium, decreasing O₂ supply and increased O₂ demand by the hypertrophied myocardium.
Decreased capillary density and co-existent atherosclerosis increase the ischaemic burden.
3. *Aortic regurgitation*: Due to decreased coronary perfusion as a result of run-off of blood back into the LV and periphery during diastole; in syphilitic AR, in addition there is coronary ostial stenosis.
4. *Hypertrophic obstructive cardiomyopathy*: Same as in aortic stenosis.
5. *Systemic hypertension*: Due to decreased diastolic coronary perfusion as a result of left ventricular hypertrophy.
6. Severe anaemia
7. Connective tissue disorders (due to arteritis)
8. Extreme tachyarrhythmias.

Palpitation

Palpitation is defined as an unpleasant awareness of forceful, arrhythmic or rapid beating of the heart.



Causes

- | | |
|-----------------------|--|
| 1. Extrasystoles | Atrial, ventricular |
| 2. Tachyarrhythmias | Atrial, ventricular |
| 3. Endocrine | Pheochromocytoma
Thyrotoxicosis
Hypoglycaemia |
| 4. High output states | Anaemia, pyrexia,
Aortic regurgitation,
Patent ductus arteriosus |
| 5. Drugs | Atropine, adrenaline,
aminophylline, thyroxine,
coffee, tea, alcohol |

6. Psychogenic
Prolonged anxiety state
(Soldier's heart, neuro-circulatory asthenia,
Da Costa's syndrome)
7. Idiopathic

Syncope

Syncope may be defined as a transient loss of consciousness due to inadequate cerebral blood flow secondary to abrupt decrease in cardiac output.

Depending on the duration of syncope, the symptoms experienced by the patient may vary.

If syncope lasts for

- 5 seconds, patient experiences dizziness
- 10 seconds, patient may become unconscious
- 15 seconds, patient may throw convulsions.

The maximum duration of syncope, with or without convulsion, may be 30 minutes.



Causes

1. Cardiac
 - (i) Electrical abnormalities
 - a. Extreme bradycardia
 - b. Heart block
 - c. Supra-ventricular or ventricular tachyarrhythmias.
 - (ii) Mechanical causes
 - a. Aortic stenosis
 - b. Hypertrophic obstructive cardiomyopathy
 - c. Left atrial tumours and thrombus
 - d. Pulmonary stenosis
 - e. Pulmonary hypertension
 - f. Pulmonary embolism
 - g. Tetralogy of Fallot.
2. Drugs
 - a. Antihypertensives
 - b. Beta blockers
 - c. Vasodilators—nitrates, ACE inhibitors.
3. Hypovolaemia: Haemorrhage, fluid loss, diabetic precoma
4. Reflexes affecting heart rate and blood pressure.
 - a. *Vasodepressor (vasovagal) syncope* is a very common cause of dizziness or syncope that characteristically occurs in response to fear, sudden emotional stress, anxiety, physical or mental exhaustion, pregnancy or anaemia. Syncope is always preceded by warning symptoms such as nausea, weakness, sweating, epigastric discomfort, blurred vision, headache, tinnitus, difficulty



in concentrating, sighing and dizziness. The heart rate falls, and the patient appears pale and ill at ease. The syncope is transient, lasting a few seconds to a few minutes, and may be prevented by immediately lying down. Rarely, this form of syncope can occur while the patient is recumbent.

- b. *Orthostatic hypotension* produces dizziness on arising or after prolonged standing and can be related to reduced effective blood volume, autonomic nervous system dysfunction, or, rarely, to circulating vasodilator substances.

Causes

Drugs—antihypertensive or antidepressant medications, vasodilators, and beta blockers

Diabetic autonomic neuropathy

Anaemia

Low blood volume

Large varicose veins

Pregnancy

Addison's disease (rare cause)

Secondary hypertension—pheochromocytoma.

- c. *Hypersensitive carotid sinus* is suspected when the patient describes dizziness or syncope after hyperextension of the neck, turning of the head, or pressure over the area of the carotid sinus from a necktie or during shaving. The syncope is evanescent, with rapid and complete recovery.
- d. Situational syncope:
- Tussive (cough) syncope* is rare and occurs with a paroxysm of non-productive violent coughing, resulting in persistent increase in intrathoracic pressure, decreased venous return to heart and therefore decreased cardiac output. The victims are almost exclusively middle-aged, overweight men with lung disease.
 - Micturition syncope* is diagnosed when syncope occurs during or after urination. The person has almost always just arisen from a period of prolonged recumbency. Onset is abrupt with little or no warning; duration is brief and followed by full recovery.
 - Deglutition syncope* is uncommon. Certain types of food or carbonated or cold beverages stimulate esophageal sensory receptors that trigger reflex sinus bradycardia or AV block resulting in syncope.
 - Defaecation syncope* occurs in older individuals with constipation and the mechanism is due to valsalva like manoeuvre.
5. Cerebrovascular disorders
- Vertebrobasilar insufficiency
 - Basilar artery migraine

6. Disorders resembling syncope:

- Hypoxia, Hypoglycaemia, Anaemia, Diminished carbon dioxide due to hyperventilation
- Psychogenic –Anxiety/Hysterical fainting
- Seizures.

Cyanosis

Cyanosis is a bluish discolouration of the skin and mucous membrane due to an increased quantity of reduced haemoglobin > 4 g per dl or $> 30\%$ of total Hb, and $\text{PaO}_2 < 85\%$, or due to the presence of abnormal haemoglobin pigments in the blood perfusing these areas.

There are two types of cyanosis – Iron-replete and iron-deplete.

Iron-replete compensated erythrocytosis establish equilibrium with haematocrits and rarely result in symptoms of hyper-viscosity because iron-replete cells are deformable.

Iron-deplete cells are less deformable and the de-compensated erythrocytosis fails to establish equilibrium with unstable, rising haematocrits, resulting in recurrent hyper-viscosity symptoms.

Phelebotomy for symptoms of hyper-viscosity which is not due to dehydration or iron deficiency is a simple outpatient procedure involving removal of 500 ml of blood over 45 minutes with isovolumetric replacement of isotonic saline.

Iron repletion in iron-deplete cyanosis must be done gradually.

Types

Central cyanosis

Peripheral cyanosis

Differential cyanosis.



Causes

In Case of Central Cyanosis

- Decreased arterial oxygen saturation
 - Decreased atmospheric pressure—high altitude
 - Impaired pulmonary function
 - Alveolar hypoventilation
 - Ventilation—Perfusion mismatch
 - Impaired oxygen diffusion.
 - Anatomic shunts
 - Cyanotic congenital heart disease
 - Pulmonary arteriovenous fistulas
 - Multiple small intrapulmonary shunts.



4. Haemoglobin with low affinity for oxygen (Hb-K).
- B. Haemoglobin abnormalities
 1. Methemoglobinaemia (> 1.5 gm per dl)
 - a. Hereditary
 - b. Acquired-drugs (nitrates, nitrites, sulpho-namides).
 2. Sulfhemoglobinaemia (> 0.5 gm per dl).
 3. Carboxyhemoglobinaemia (smokers).

The diagnosis of methemoglobinaemia can be suspected, if on exposing the patient's blood to air, it remains brown whereas in cyanosis due to decreased arterial oxygen saturation, it turns bright red.

In Case of Peripheral Cyanosis

1. Reduced cardiac output
2. Cold exposure
3. Redistribution of blood flow from extremities
4. Arterial obstruction
5. Venous obstruction.

In Case of Differential Cyanosis

1. Cyanosis is seen only in the lower limbs—Patent ductus arteriosus with pulmonary hypertension, with right to left shunt.
2. Cyanosis is seen only in the upper limbs—Patent ductus arteriosus with pulmonary hypertension, with right to left shunt and transposition of great vessels.
3. Rarely, in addition to the lower limbs, the left upper limb may also be cyanosed when the patent ductus opens proximal to the origin of left subclavian artery.

Intermittent Cyanosis is seen in Ebstein's anomaly.

Differentiating Features Between Central and Peripheral Cyanosis

Features	Central cyanosis	Peripheral cyanosis
Mechanism	Right to left shunts or lung disorders	Peripheral stasis
Site	Whole body	Nail bed, nose tip, earlobe, extremities
Associations	Clubbing Polycythaemia	- -
Extremities	Warm	Cold
On warming the extremities	No change	Disappears
O ₂ inhalation	Slight improvement	No change
Arterial blood gas-PaO ₂	Low < 85%	Normal 85–100%

Arterial Pulse

A pulse wave is a waveform that is felt by the finger, produced by cardiac systole, which traverses the arterial tree in a peripheral direction at a rate much faster than that of the blood column.

Artery	Time at which pulse wave arrives after cardiac systole
Carotid	30 milliseconds
Brachial	60 milliseconds
Femoral	75 milliseconds
Radial	80 milliseconds

Arterial pulse is assessed in the following way:

1. Rate
2. Rhythm
3. Volume
4. Character
5. Whether felt in all peripheral vessels
6. Radio femoral delay.
Radial pulse is felt to assess rate and rhythm.
Carotid pulse is felt to assess volume and character.
Brachial pulse is felt to record blood pressure.
7. Condition of the vessel wall.

Pulse can be recorded in the following way:

Normal	+
Reduced	±
Absent	-
Aneurysmal	++

Pulse Rate

Pulse rate should be counted for one full minute by palpating the radial artery (Fig. 3.1).

Normal pulse rate is 60-100 per minute

Sinus bradycardia—pulse rate < 60 per minute

Sinus tachycardia—pulse rate > 100 per minute.



Fig. 3.1: Palpating the radial artery by compressing over the styloid process of radial bone



Causes of Sinus Bradycardia

- Physiological
 - Athletes
 - Sleep
- Pathological
 - Severe hypoxia
 - Hypothermia
 - Sick sinus syndrome
 - Myxoedema
 - Obstructive jaundice
 - Acute inferior wall infarction
 - Raised intraocular pressure
 - Raised intracranial tension
 - Heart blocks
 - Drugs (beta blockers, verapamil, diltiazem, digoxin).



Causes of Sinus Tachycardia

- Physiological
 - Infants
 - Children
 - Emotion
 - Exertion.
- Pathological
 - Tachyarrhythmias*: supra-ventricular, ventricular.
 - High output states*: anaemia, pyrexia, beriberi, thyrotoxicosis, pheochromocytoma, arteriovenous fistula.
 - Acute anterior wall myocardial infarction.
 - Cardiac failure, cardiogenic shock.
 - Hypovolemia, hypotension.
 - Drugs (atropine, nifedipine, beta agonists— salbutamol, thyroxine, catecholamines, nicotine, caffeine).

Pulse Deficit (Apex-Pulse Deficit)

It is the difference between the heart rate and the pulse rate, when counted simultaneously for one full minute.



Causes

- Atrial fibrillation
- Ventricular premature beats.

Differentiating Features between VPC and AF

Features	Ventricular Pre-mature Beats (VPCs)	Atrial Fibrillation (AF)
Pulse deficit	Less than 10 per min.	More than 10 per min.
'a' wave in JVP	Present	Absent
On exertion	Decreases or disappears	Persists or increases
Rhythm	Short pause (between normal beat and VPC) followed by a long pause (following VPC)	Pauses are variable and chaotic

Rhythm

Rhythm is assessed by palpating the radial artery. In certain conditions rhythm may be irregular.

Regularly Irregular Rhythm

Seen in

- i. Atrial tachyarrhythmias (PAT and atrial flutter) with fixed AV block
- ii. Ventricular bigemini, trigemini.

Irregularly Irregular Rhythm

Seen in

- i. Atrial or ventricular ectopics
- ii. Atrial fibrillation
- iii. Atrial tachyarrhythmias (PAT and atrial flutter) with varying AV blocks.

Pulse Volume

Pulse volume is best assessed by palpating the carotid artery. However, the pulse pressure (the difference between systolic and diastolic BP), gives an accurate measure of pulse volume.

When pulse pressure is between 30 and 60 mm Hg, pulse volume is normal.

When pulse pressure is less than 30 mm Hg, it is a small volume pulse.

When pulse pressure is greater than 60 mm Hg, it is a large volume pulse.

Pulse volume depends on stroke volume and arterial compliance.

Pulse Character

Pulse character is best assessed in the carotid arteries (Figs 3.2 and 3.3).

Hypokinetic Pulse (Fig. 3.4)

Small weak pulse (small volume and narrow pulse pressure).



Causes

- Cardiac failure
- Shock
- Mitral stenosis
- Aortic stenosis.

Anacrotic Pulse (Parvus et Tardus) (Fig. 3.5)

A low amplitude pulse (parvus) with a slow rising and late peak (tardus). It is seen in severe valvular aortic stenosis.



Palpating the left carotid artery with right thumb



Palpating the right carotid artery with left thumb



Palpating the brachial pulse just medial to biceps tendon



Palpating the brachial pulse against the lower end of humerus



Locating the posterior tibial pulse behind the medial malleolus



Palpating the dorsalis pedis pulse lateral to ext. hallucis longus

Fig. 3.2: Examination of peripheral pulses

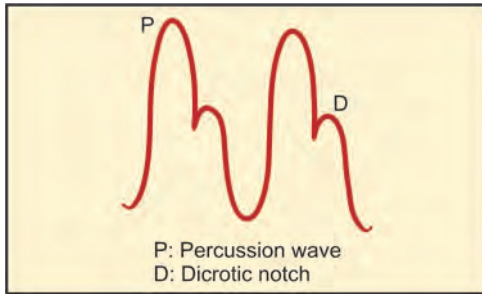

Fig. 3.3: Normal pulse

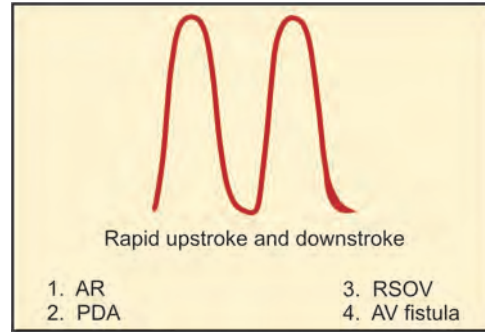

Fig. 3.7: Collapsing pulse

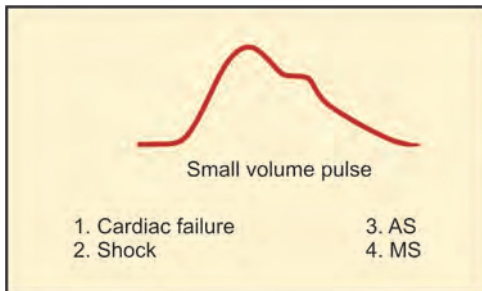

Fig. 3.4: Hypokinetic pulse

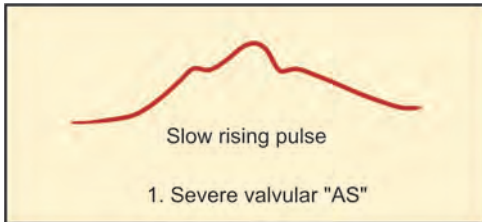

Fig. 3.5: Pulsus parvus et Tardus

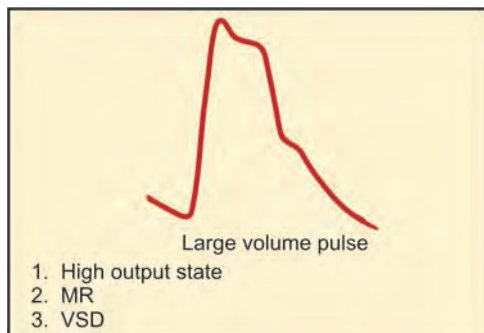

Fig. 3.6: Hyperkinetic pulse

Hyperkinetic Pulse (Fig. 3.6)

A high amplitude pulse with a rapid rise (large volume and wide pulse pressure).



Causes

High output states—Anaemia, pyrexia, beriberi



Fig. 3.8: Raise the arm to feel for the collapsing pulse

Mitral regurgitation
Ventricular septal defect.

Collapsing Pulse (Water-Hammer Pulse, Corrigan Pulse) (Figs 3.7 and 3.8)

It is a large volume pulse with a rapid upstroke (systolic pressure is high) and a rapid downstroke (diastolic pressure is low).

The rapid upstroke is because of an increased stroke volume. The rapid downstroke is because of diastolic run-off into the left ventricle, and decreased peripheral resistance and rapid run-off to the periphery.

Decreased peripheral resistance is due to large stroke volume stretching carotid and aortic sinus leading to reflex decrease in peripheral resistance.



Causes

Patent ductus arteriosus
Aortic regurgitation

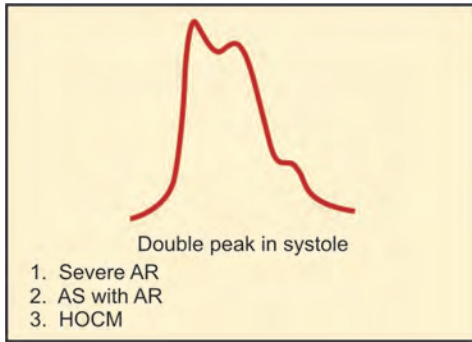

Fig. 3.9: Bisferiens pulse

Arteriovenous fistula

Rupture of sinus of Valsalva.

Thready pulse is seen in shock.

Jerky pulse is seen in HOCM.

Pulsus Bisferiens (Fig. 3.9)

Pulsus bisferiens is a single pulse wave with two peaks in systole.

This is best felt in brachial and femoral artery. It is due to ejection of rapid jet of blood through the aortic valve. During the peak of flow, Bernoulli's effect on the walls of ascending aorta causes a sudden decrease in lateral pressure on the inner aspect of the wall.



Causes

Aortic stenosis and aortic regurgitation

Severe aortic regurgitation

Hypertrophic obstructive cardiomyopathy (HOCM)

Dissection of aorta (unilateral bisferiens).

Pulsus Dicroticus (Fig. 3.10)

It is a single pulse wave with one peak in systole and one peak in diastole due to a very low stroke volume with decreased peripheral resistance.

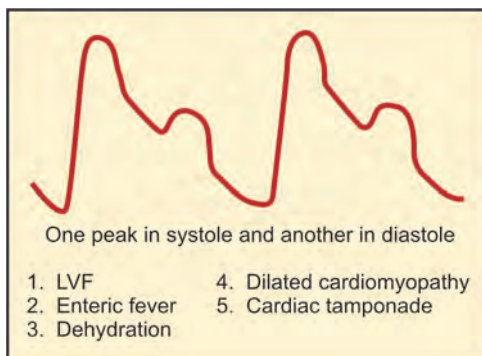

Fig. 3.10: Dicrotic pulse

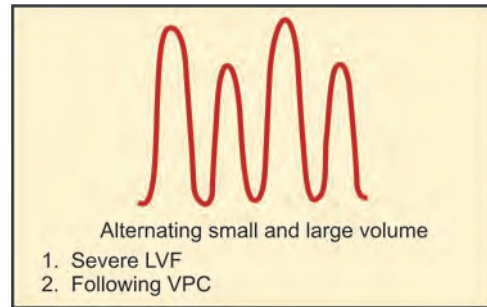

Fig. 3.11: Pulsus alternans



Causes

Left ventricular failure

Typhoid fever

Dehydration

Dilated cardiomyopathy

Cardiac tamponade.

Pulsus Alternans (Fig. 3.11)

Alternating small and large volume pulse in regular rhythm. It is best appreciated by palpating radial or femoral pulses, rather than the carotids.



Causes

- It is a sign of severe left ventricular dysfunction
- It may occur following paroxysmal tachycardia
- It may occur for several beats, following a pre-mature beat, in an otherwise normal heart.

Coupled ventricular pre-mature beats may also mimic pulsus alternans, but however the rhythm is irregular.

Pulsus alternans may be associated with S_3 and electrical alternans—alternate small and large ECG complexes (in 10% of cases).

Pulsus Bigeminus

A pulse wave with a normal beat followed by a pre-mature beat and a compensatory pause, occurring in rapid succession, resulting in alternation of the strength of the pulse.

In pulsus alternans, compensatory pause is absent, whereas in pulsus bigeminus, compensatory pause is present. Pulsus bigeminus is a sign of digitalis toxicity.

Pulsus Paradoxus (Fig. 3.12)

It is an exaggerated reduction in the strength of arterial pulse during normal inspiration or an exaggerated inspiratory fall in systolic pressure of more than 10 mm Hg during quiet breathing.

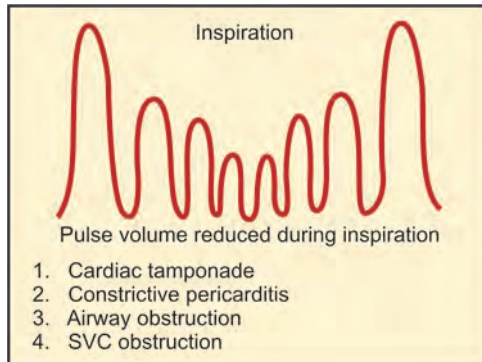

Fig. 3.12: Pulsus paradoxus



Causes

Cardiac tamponade
 Constrictive pericarditis
 Airway obstruction—acute severe asthma
 SVC obstruction.

Reverse pulsus paradoxus is an inspiratory rise in arterial pressure.



Causes

Hypertrophic obstructive cardiomyopathy
 Intermittent positive pressure ventilation
 Atrioventricular dissociation.

Radio-femoral Delay (Fig. 3.13)

Delay of the femoral compared with the right radial pulse is found in coarctation of the aorta.



Fig. 3.13: Method of examination for radio-femoral delay

Blood Pressure

The lateral force exerted by the blood column per unit area of the vascular wall that is expressed in mm of Hg.

Korotkoff Sounds

Korotkoff sounds should be examined preferably with bell of the stethoscope. There are five phases of korotkoff sounds, i.e. the sounds produced by the flow of blood as the constricting BP cuff is gradually released.

- Phase I First appearance of clear, tapping sound. It represents the systolic blood pressure
- Phase II Tapping sounds are replaced by soft murmurs
- Phase III Murmurs become louder
- Phase IV Muffling of sounds
- Phase V Disappearance of sounds.

Diastolic pressure closely corresponds to phase V. However, in aortic regurgitation, the disappearance point is extremely low, sometimes 0 mm Hg and so phase IV is taken as diastolic BP in adults as well as children.

When Korotkoff sounds are not heard while recording BP, ask the patient to raise the cuffed upper limb and ask him to open and close the fist of that hand repeatedly and then record the BP.

The length of the bladder is approximately twice that of the width. The average length of the rubber bag is 25 cm.

The air bag within the cuff should extend for at least 2/3rd of the arm length and circumference.

The midportion of the rubber bag within the cuff should lie over the brachial artery.

After inflation, the cuff should be deflated at a rate of 2–3 mm Hg per second.

Auscultatory Gap

Occasionally, after the initial appearance of the Korotkoff sounds, indicating the systolic pressure, the sounds disappear for sometime, to re-appear again and finally disappear at the diastolic pressure.

This phenomenon of a silent gap is found in certain patients with hypertension. It overestimates the diastolic pressure and underestimates the systolic pressure thereby necessitating the palpatory method of BP recording to always precede the auscultatory method.

Auscultatory gap occurs when there is venous distension or reduced velocity of arterial flow in the arm.

Various Cuff Sizes for BP Measurement

Age in Years	Width of the bladder of the cuff
< 1 yr	2.5 cm
1–5 yrs	5 cm
6–10 yrs	10 cm
Normal adult	12.5 cm
Obese adult	14 cm
Thigh	20–25 cm



Blood Pressure in the Basal Condition

In order to determine BP in basal condition, the patient should have rested in a quiet room for 15 minutes. He should not have consumed coffee or tea for the preceding one hour or smoked for the preceding 15 minutes. He should not be on adrenergic stimulants and there should be no bladder distension.

It is desirable to record the BP in both the arms as the differences in systolic pressure exceeding 10 mm Hg between the two arms when measured simultaneously or in rapid sequence suggest obstructive lesions of aorta, innominate or subclavian arteries.

In vertebrobasilar insufficiency, a difference in pressure between the arms may signify that a subclavian steal is responsible for cerebrovascular symptoms.

Normally systolic pressure in the legs is up to 20 mm Hg higher than in the arms, but diastolic BP is the same.

When systolic pressure in the popliteal artery exceeds that in brachial artery by > 20 mm Hg (Hill's sign), AR is usually present.

Measuring lower limb BP is useful in detecting coarctation of aorta or obstructive disease of the aorta or its immediate branches.

Postural or Orthostatic Hypotension

BP must be recorded in lying, sitting and standing positions especially when postural hypotension is suspected.

When there is a fall in systolic pressure of > 20 mm Hg after standing for 3 minutes, from the lying posture, the patient is said to have postural hypotension.



Causes

1. Hypovolaemia (blood or fluid loss)
2. Autonomic neuropathy (diabetes mellitus, old age)
3. Drugs (ganglion blocking agents, centrally acting anti-hypertensives)
4. Myocardial pump failure
5. Secondary hypertension* (pheochromocytoma).

In atrial fibrillation, an average of three BP recordings in the same limb must be taken.

Normal Blood Pressure

Systolic 100-140 mm Hg.

Diastolic 60-90 mm Hg.

Pulse pressure is the difference between systolic and diastolic blood pressure.

*When there is a rise in diastolic BP in the standing posture, it is more in favour of essential hypertension.

Normal pulse pressure is 30-60 mm Hg.

Mean arterial pressure is the product of cardiac output and total peripheral resistance. It is the tissue perfusion pressure.

Mean arterial pressure = Diastolic blood pressure + 1/3 of pulse pressure.

Normal mean arterial pressure is approximately 100 mm Hg.

To confirm the presence of hypertension, multiple BP recordings should be taken with a mercurial manometre on several occasions. Home monitoring and ambulatory monitoring are preferable as they eliminate anxiety.

JNC 7 Classification of Hypertension

(The seventh report of the joint national committee on prevention, detection, evaluation and treatment of high blood pressure)

Category	Systolic pressure (mm Hg)	Diastolic pressure (mm Hg)
Normal	< 120	< 80
Pre-hypertension	120-139	80-89
Hypertension		
Stage 1	140-159	90-99
Stage 2	>160	>100

When the diastolic pressure is below 90 mm Hg, a systolic pressure

below 140 mm Hg indicates normal blood pressure.

between 140-149 mm Hg indicates borderline isolated systolic hypertension

140 mm Hg or higher indicates isolated systolic hypertension.

When there is an elevation of systolic pressure of > 30 mm Hg and a diastolic pressure of > 20 mm Hg from the basal original level, it indicates presence of hypertension.



Common Causes of Hypertension

1. Essential or primary hypertension (94%)
2. Secondary hypertension (6%)
 - a. Renal (4%)
 - b. Endocrine (1%)
 - c. Miscellaneous (1%).

Isolated Systolic Hypertension

This is said to be present when systolic blood pressure is > 140 mm Hg and diastolic blood pressure is < 90 mm Hg. It is commonly seen in old age (above 65 years).



Accelerated Hypertension

A significant recent increase in blood pressure over previous hypertensive levels, associated with evidence of vascular damage on fundoscopic examination, but without papilloedema.

Malignant Hypertension

A triad of blood pressure of $> 200/140$ mm Hg, grade IV retinopathy (papilloedema) and renal dysfunction.

Hypertensive Urgency

This is a situation in which the BP is markedly elevated, but without any evidence of end organ damage. In this condition, the control of the elevated BP can be done gradually.

Hypertensive Emergency

This is a situation in which the BP is markedly elevated, but with evidence of some end organ damage. In this condition, the control of the elevated BP has to be done immediately in order to prevent further end organ damage.

White Coat Hypertension

A transient increase in blood pressure in normal individuals, when BP is recorded in a physician's consulting room, or in a hospital.

Pseudohypertension

A false increase in blood pressure recording due to stiff and noncompliant vessels (Osler's sign), occurring in old age. In these individuals, actual intra-arterial BP is lower than the BP measured by a sphygmomanometer.

Transient Hypertension

This may be seen in

- Acute cerebrovascular accidents
- Acute myocardial infarction
- Acute glomerulonephritis
- Pregnancy
- Acute intermittent porphyria.

It is systemic hypertension seen for a transient phase of time when the patient is under stress or when he is having a disorder with a transient hypertensive phase, as may occur in the above-mentioned conditions.

Episodic or Paroxysmal Hypertension

This is seen in pheochromocytoma. However, a patient with pheochromocytoma may be normotensive, hypotensive or hypertensive.

Labile Hypertension

Patients who sometimes, but not always have arterial pressure within the hypertensive range, are classified as having labile hypertension.

Paradoxical Hypertension

In this form of hypertension, patients paradoxically show an increase in BP, even when on antihypertensive drugs.

Examples

1. Patients with DM and HTN, on β blockers, on developing hypoglycaemia show a paradoxical rise over previously well-controlled BP. This is because the excess adrenaline released secondary to hypoglycaemia, acts unopposed on the α_1 receptors and thereby raises the BP.
2. With high doses of clonidine, the peripheral α_1 receptors are stimulated, apart from its central action, thereby raising the BP.
3. In patients with bilateral renal artery stenosis, administration of ACE inhibitors, results in a paradoxical rise in BP.
4. Administration of β blockers in patients with pheochromocytoma leads to uninhibited α receptor stimulation by epinephrine leading to paradoxical rise in BP.

Hypertensive States

These are situations in which there is a marked increase in both systolic and diastolic BP, occurring in normal individuals, as during sexual intercourse or on diving into cold water.

Measurement of BP may be useful in detecting

1. Pulsus paradoxus
2. Pulsus alternans.

Pulsus Paradoxus

Inflate the BP cuff to suprasystolic level and deflate slowly at a rate of 2 mm Hg per heart beat. The peak systolic pressure during expiration is noted. The cuff is then deflated even more slowly, and the pressure is again noted when Korotkoff sound becomes audible throughout the respiratory cycle. Normally the difference between the two pressures should not exceed 10 mm Hg during quiet respiration. If it is more than 10 mm Hg, pulsus paradoxus is said to be present.

Paradox: Heart sounds are still heard over the precordium at a time when no pulse is palpable at the radial artery.

Pulsus Alternans

Inflate the BP cuff to suprasystolic level and deflate slowly. Pulsus alternans is present if there is an alteration in the intensity of Korotkoff sound.

Examination of Neck Veins

Examination of the neck veins has a two-fold purpose.

1. To assess approximately the mean right atrial pressure.
2. To study the waveforms.

Jugular Venous Pressure

Jugular venous pressure (JVP) is expressed as the vertical height from the sternal angle to the zone of transition of distended and collapsed internal jugular veins. When measured with the patient reclining at 45° is normally about 4-5 cm.

The right internal jugular vein is selected because it is larger, straighter and has no valves. It is situated between two heads of sternomastoid.

Patient Position in Examination of JVP

Since right atrial pressure is often very low, optimal positioning of the patient to visualise the column of venous blood above the level of the clavicle is critical. The examiner must position the patient's upper thorax so that the column of blood in the internal jugular vein is visible in the neck. In general, in positioning the patient, the lower the pressure in the venous system, the more supine the patient's position should be; the higher the pressure, the more upright the patient's position should be (Fig. 3.14).



Fig. 3.14: Measurement of jugular venous pressure

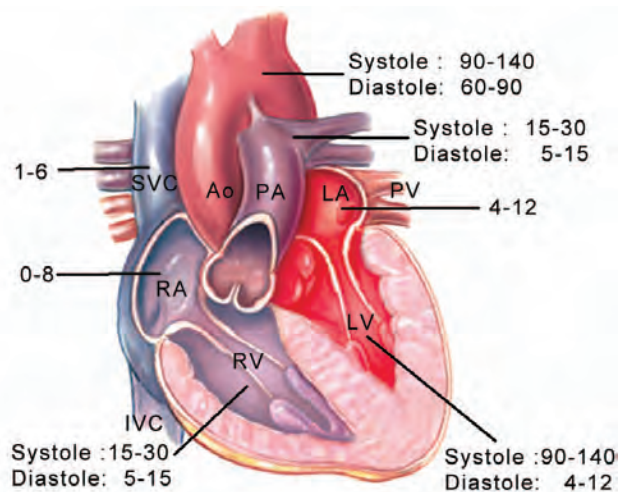

Fig. 3.15: Pressure in heart chambers (in mm Hg)

JVP as Indicator of Mean Right Atrial Pressure

The overall height of the pulsating column is an indicator of mean right atrial pressure, which can be estimated based on a simple anatomic fact, that in most individuals, the centre of the right atrium is approximately 5 cm from the sternal angle of Louis. This relation is maintained in every position between supine and upright posture. Thus, the vertical height of the column of blood in the neck can be estimated from the sternal angle, to which 5 cm is added to obtain an estimate of mean right atrial pressure in centimeters of blood. This amount can be converted to millimetres of mercury by multiplying by 0.736. Normal values are less than 8 cm of blood or less than 6 mm Hg. This estimation may be erroneous in patients with deformed chest walls or malpositioning of the heart (Fig. 3.15).

Causes of Elevated JVP

- | | |
|-----------------------------|--|
| 1. Unilateral non-pulsatile | Innominate vein thrombosis |
| 2. Bilateral non-pulsatile | SVC obstruction
Massive right sided pleural effusion |
| 3. Bilateral pulsatile | |
| a. Cardiac | Cardiac failure
Tricuspid stenosis
Tricuspid regurgitation
Constrictive pericarditis
Cardiac tamponade |
| b. Pulmonary | COPD/cor pulmonale |
| c. Abdominal | Ascites
Pregnancy |
| d. Iatrogenic | Excess IV fluids |

Most common cause of raised JVP is CCF.

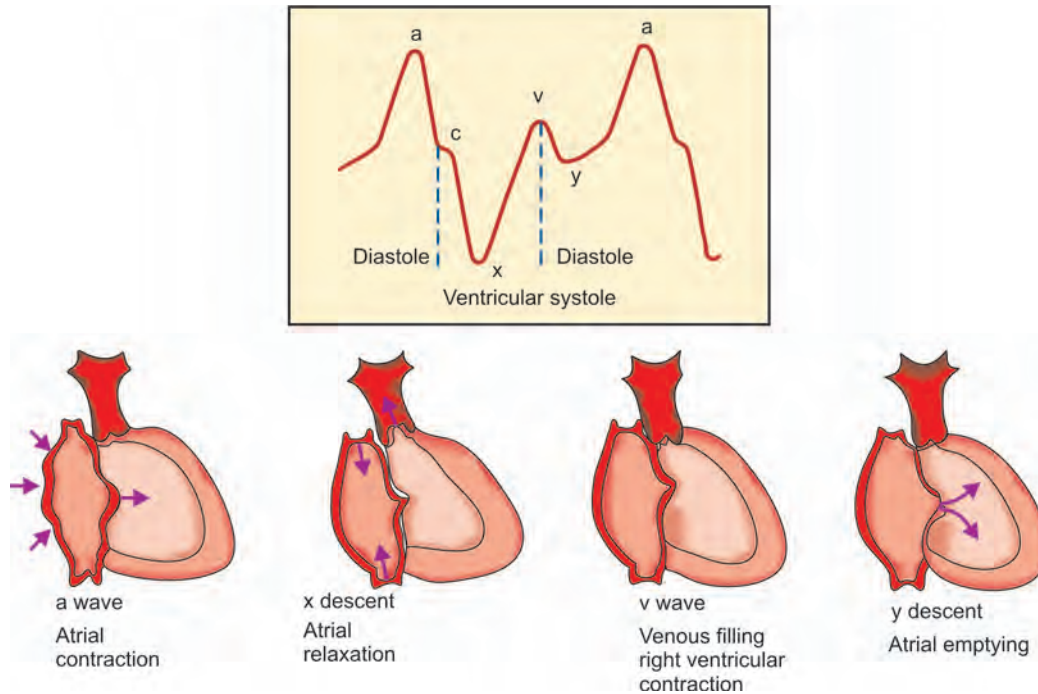

Fig. 3.16: Jugular venous pulse



Causes of Fall in JVP

- Hypovolaemia
- Shock
- Addison's disease.

Jugular Venous Pulse (JVP)

JVP is the reflection of phasic pressure changes in the right atrium and consists of three positive waves (a, c, v) and two negative troughs (x, y) (Fig. 3.16).

Differentiating Features Between Carotid Artery Pulse and JVP

Carotid artery pulse	Jugular venous pulse
Seen internal to the sternomastoid	Seen in the triangle formed by the two heads of the sternomastoid and the clavicle
Better palpable	Better visible
Predominant outward movement	Predominant inward movement
One peak per heart beat	Two peaks per heart beat
No variation with posture or respiration	Variation with posture, respiration, abdominal compression.
Not obliterable	Obliterable

Abnormalities of JVP

- 'a' wave
 - Absent
 - Atrial fibrillation
 - Present
 - Prominent 'a' waves
 - a. Pulmonary stenosis
 - b. Pulmonary hypertension
 - c. Tricuspid atresia or stenosis.

Waves in JVP	Cardiac event
'a' wave (atrial wave)	Right atrial contraction
'c' wave (closure wave)	Carotid artery impact Tricuspid valve ascends
'x' wave	Right atrial relaxation
'x'-wave	Tricuspid valve descends
'v' wave (ventricular wave)	Venous filling into atrium
'y' wave	Tricuspid valve opens

- 'a' wave precedes S1
- 'c' wave succeeds S1
- 'x' wave precedes S2
- 'y' wave succeeds S2
- Cannon waves (Giant 'a' waves seen in arrhythmias)
 - Regular: Junctional rhythm
 - Irregular: Multiple ectopics, Complete heart block
- Independent 'a' waves: Complete heart block
- 'v' wave: Prominent: Tricuspid regurgitation
- 'x' descent: Prominent: Constrictive pericarditis



'y' descent	Slow	Tricuspid stenosis
	Fast	Tricuspid regurgitation
	Absent	Cardiac tamponade.

Kussmaul's sign is an inspiratory increase in JVP.

Friedreich's sign is the rapid fall (steep 'y' descent) and rise of JVP seen in constrictive pericarditis and tricuspid regurgitation.



Causes of Kussmaul's sign

Constrictive pericarditis
Restrictive cardiomyopathy
Right ventricle infarct
Right ventricle failure.

Abdominal Jugular Reflux

Firm compression is given in the periumbilical area for 30 seconds. In normal individuals the JVP rises transiently by less than 3 cm and falls down even when pressure is continued, whereas in patients with right or left heart failure, the JVP remains elevated.

Abdominal jugular reflux is positive in right or left heart failure and/or tricuspid regurgitation. In the absence of these conditions, a positive abdominal jugular reflux suggests an elevated pulmonary artery wedge or central venous pressure. It is negative in Budd-Chiari syndrome.

General Examination

External Features of Cardiac Disease

- In congenital heart disease look for:
 - Cyanosis
 - Clubbing
 - Polycythaemia
 - Hypertelorism
 - Low set ears
 - High arched palate
 - Webbed neck
 - Syndactyly, Polydactyly, Arachnodactyly (Polydactyly: Trisomy 13 to 1 and 18. Bradydactyly: Down's, Turner's, Ellis-de Crevald syndromes)
 - Cubitus valgus, Absent radius
 - Pectus excavatum, carinatum
 - Kyphoscoliosis, Shield chest
 - Abdominal hernia, Cryptorchidism
 - Upper segment/Lower segment inequality
 - Dwarfism
 - Gigantism

- In acquired heart disease look for:
 - Markers of Rheumatic Fever*
Joint swelling (Migrating polyarthritis involving major joints, leaving no residual deformities)
Erythema marginatum
Subcutaneous nodules.
 - Markers of Infective Endocarditis*
Anaemia, jaundice
Clubbing, splinter haemorrhages
Osler's nodes
Janeway lesions
Arthritis.
Embolitic complications of IE:
 - Osler's node – painful
 - Janeway lesion – painless
 - Splinter haemorrhage
 - Markers of Coronary Heart Disease*
Arcus senilis
Xanthelasma, xanthomas
Earlobe creases – diagonal
Nicotine stains on fingers and teeth
Obesity
Arcus senilis—Starts superiorly and no iris is visible between limbus and arcus
Corneal arcus—Starts inferiorly and iris is visible between limbus and arcus.

Fundus in Cardiology

- Infective endocarditis*—Roth's spot
- Hypertensive retinopathy* (Fig. 3.17)

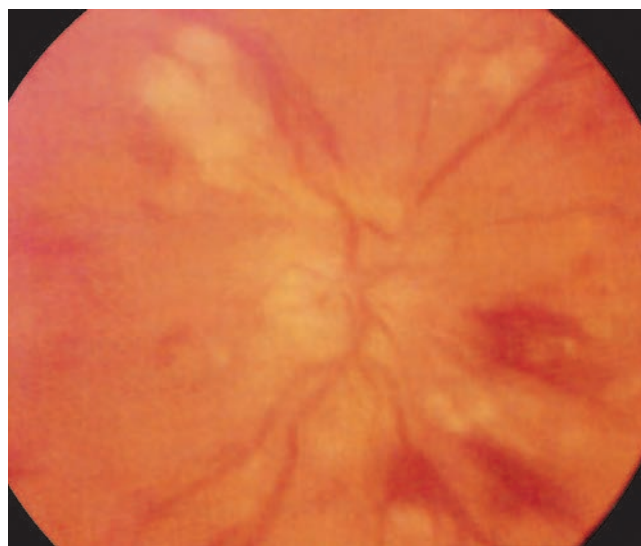

Fig. 3.17: Malignant hypertension—grade IV retinopathy



Keith-Wagner-Barker Grading of Hypertensive Retinopathy

Degree	AV Ratio (Ratio of Arterial to Venous Diameter)	Haemorrhages	Exudates	Papilloedema
Normal	3 : 4	0	0	0
Grade I (focal spasm)	1 : 2	0	0	0
Grade II (AV nipping)	1 : 3	0	0	0
Grade III	1 : 4	+	+	0
Grade IV	fine, fibrous cords	+	+	+

C. Arteriosclerotic retinopathy

Grades	Vessels
Normal	Fine yellow lines
I	Broad yellow lines
II	Copper wire appearance
III	Silver wire appearance
IV	Fibrous cords

D. Cor pulmonale—Papilloedema (Increased CSF pressure due to CO₂ retention).

Inspection

Precordium is the anterior aspect of chest overlying the heart.

Precordial bulge indicates the presence of right ventricular hypertrophy presenting since early childhood.

Visible Pulsations

Carotid artery pulsation	Hyperdynamic states Aortic regurgitation Coarctation of aorta Systemic hypertension
Aortic pulsation	Dilatation of ascending aorta Aortic aneurysm Aortic regurgitation
Pulmonary artery pulsation	Pulmonary artery dilatation High output states Pulmonary hypertension Pulmonary hypercirculation (ASD)
Suprasternal pulsation	Aortic regurgitation Aortic arch aneurysm Thyrotoxicosis Coarctation of aorta
Supraclavicular pulsation	Aortic regurgitation Subclavian artery aneurysm

Sternoclavicular pulsation	Aortic regurgitation Aortic dissection Aortic aneurysm Right sided aortic arch (TOF)
Left parasternal pulsation	Right ventricular hypertrophy Mitral regurgitation
Apical pulsation	May be due to left ventricular or right ventricular enlargement
Ectopic pulsation	Ischaemic heart disease Left ventricular dysfunction or aneurysm Cardiomyopathies
Inter and infra scapular pulsations	Coarctation of aorta (Suzman's sign)
Epigastric pulsation	Aortic aneurysm (expansile pulsation) Tumour or nodes over the aorta (transmitted pulsation) Aortic regurgitation Right ventricular hypertrophy Hepatic pulsation (left lobe of liver)
Hepatic pulsation	Tricuspid stenosis Tricuspid regurgitation Aortic regurgitation

Chest wall defects

Sternum	Pectus excavatum, Pectus carinatum
Costal cartilages	Costochondritis
Spine	Kyphosis, scoliosis Ankylosing spondylitis Straight back syndrome.

Palpation

General rule (Fig. 3.18): The fingertips are used to feel pulsations, the base of fingers for thrills and hand base for heaves. Ideal position is supine or upper trunk elevated to 30°.

Apical Impulse

Apical impulse is the lower most and outer most point of definite cardiac impulse with a maximum perpendicular thrust to the palpating finger.

Normal apical impulse is produced by left ventricle and the left ventricular portion of the interventricular septum.

Normal site of the apical impulse is about

- 1 cm medial to midclavicular line or 10 cm lateral to midsternal line at the left 5th intercostal space in adults.

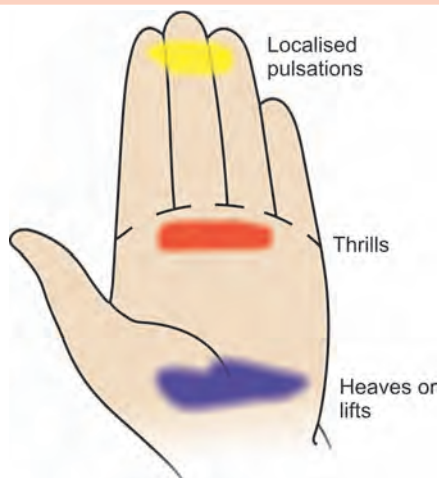

Fig. 3.18: Application of hand in cardiac palpation

- Normal displacement is 1 cm laterally in left lateral decubitus position.
- Normal apical impulse is confined to one intercostal space and has an area of 2.5 cm².
- Normal duration of thrust of apical impulse is less than 1/3 of systole.

Golden Rules

Before commenting on the position and character of apical impulse, look for the presence of chest wall or spinal deformities, and the tracheal position.

When the apical impulse is not localisable on the left side, palpate the right hemithorax for its presence (dextrocardia or pseudo-dextrocardia) (Figs 3.19 to 3.21).

Abnormalities of Apical Impulse

- | | |
|---------------------------|---|
| 1. Absent apical impulse | Behind the rib or sternum
Dextrocardia |
| 2. Tapping apical impulse | Palpable S ₁ (closing snap),
e.g. Mitral stenosis |



Fig. 3.19: Palpating the apical impulse with hand



Fig. 3.20: Locating the apical impulse with the finger



Fig. 3.21: Character of apical impulse is best studied in left lateral position

- | | |
|---|---|
| 3. Hypodynamic apical impulse (felt with decreased thrust) | Obesity
Acute myocardial infarction
Pleural effusion
Pericardial effusion
Constrictive pericarditis
COPD |
| 4. Hyperdynamic apical impulse is one in which there is an increase in amplitude without an increase in duration. | |
| 5. Heaving apical impulse is one in which there is increase in both amplitude and duration. | |
| 6. Diffuse apical impulse | Left ventricular aneurysm
Left ventricular dysfunction |
| 7. Double apical impulse | HOCM
Left ventricular aneurysm
AS with AR
Left bundle branch block |
| 8. Triple or quadruple apical impulse | HOCM |
| 9. Retractable apical impulse | Constrictive pericarditis
Severe TR. |



Differentiating Features between Heaving and Hyperdynamic Apical Impulse

Features	Heaving	Hyperdynamic
Time	Increased	Normal
Amplitude	Increased	Increased
Duration	> 2/3 of systole	> 1/3 to < 2/3 of systole
Location	Occupies one intercostal space	Occupies more than one intercostal space
Causes	LV pressure overload, e.g. AS, HTN, Coarctation of aorta	LV volume overload, e.g. AR, MR, VSD, PDA, High output states

Parasternal Impulse

Parasternal impulse is the anterior movement of lower left parasternal area (Fig. 3.22).

Grading of parasternal impulse (AIIMS grading)

- Grade I Visible but not palpable
- Grade II Visible and palpable but obliterated
- Grade III Visible and palpable but not obliterated.

Parasternal impulse can be seen in

- Right ventricular enlargement or
- Left atrial enlargement



Causes of Right Ventricular Enlargement

Volume overload: Fast, ill-sustained parasternal impulse—Left to right shunts, e.g. ASD, VSD.

Pressure overload: Slow, sustained parasternal impulse, e.g. PS.

Left Atrial Enlargement

Left atrial enlargement is seen in mitral stenosis and mitral regurgitation. Aneurysmal dilatation of left atrium (giant left atrium) is seen in severe mitral regurgitation.



Fig. 3.22: Method of palpation for parasternal heave. Place the base of hand over the left parasternal area

Shocks

Shocks are palpable equivalents of heart sounds.

Site	Shock	Cause
Aortic area	A ₂ Aortic ejection click	Systemic hypertension Congenital valvular aortic stenosis Aortic root dilatation
Pulmonary area	P ₂ Pulmonary ejection click	Pulmonary hypertension Pulmonary valvular stenosis Pulmonary artery dilatation
Apical	S ₁ Opening snap S ₃ S ₄	Mitral stenosis Mitral stenosis DCM HOCM

Thrills

Thrills are palpable vibrations in time with cardiac cycle. They are palpable equivalents of heart murmurs.

The presence of a thrill indicates that the murmur is most of the time organic. As a general rule, apical thrills are diastolic and basal thrills are systolic. However, apical thrill may be systolic (as in severe MR) and basal thrills may be diastolic (as in acute severe AR).

Carotid Thrill (Carotid Shudder)

In aortic stenosis, systolic thrill (Carotid shudder) is palpated over the carotids.

Aortic Thrills (Fig. 3.23)

- | | |
|------------------|---|
| Systolic thrill | Aortic stenosis |
| Diastolic thrill | a. Acute severe aortic regurgitation due to eversion, infection or perforation of the valve |
| | b. Syphilitic aortic regurgitation. |



Fig. 3.23: Palpating base. Aortic thrills are better felt in leaning forward position

**Pulmonary Thrills**

Systolic thrill	Pulmonary stenosis Atrial septal defect (30%) Ventricular septal defect Patent ductus arteriosus
Continuous thrill	Patent ductus arteriosus Rupture of sinus of Valsalva.

Left Lower Parasternal Thrills

Systolic thrill	Ventricular septal defect
-----------------	---------------------------

Apical Thrills

Diastolic thrill	Mitral stenosis
Systolic thrill	Mitral regurgitation Aortic stenosis (as sometimes, aortic events are best appreciated in the mitral area).

Carey Coombs' murmur and Austin Flint's murmur are not associated with a thrill.

Percussion

Percussion may be useful in the following conditions only. It is useful in detecting aortic dilatation as in aneurysm of aorta and pulmonary artery dilatation as in pulmonary hypertension or idiopathic pulmonary artery dilatation.

It is also helpful for finding out the position and enlargement of heart as in

- *Dextrocardia with or without situs inversus
- Pericardial effusion
- Dilated cardiomyopathy.

Auscultation

Ideal stethoscope should have well fitting earpieces and a thick long tube of 25 cm length and diameter of 0.325 cm, a diaphragm of 4 cm diameter and a bell of 2.5 cm diameter.

Bell of Stethoscope is Used to Auscultate (Fig. 3.24)

Low pitched sounds and murmurs
Third heart sound
Fourth heart sound
Mid diastolic murmurs.

Diaphragm of Stethoscope is Used to Auscultate (Fig. 3.25)

High pitched sounds and murmurs
First heart sound

*Congenital heart disease is commonly associated with isolated dextrocardia rather than when dextrocardia is associated with situs inversus.



Fig. 3.24: Auscultate with bell in left lateral position (for mitral stenosis)

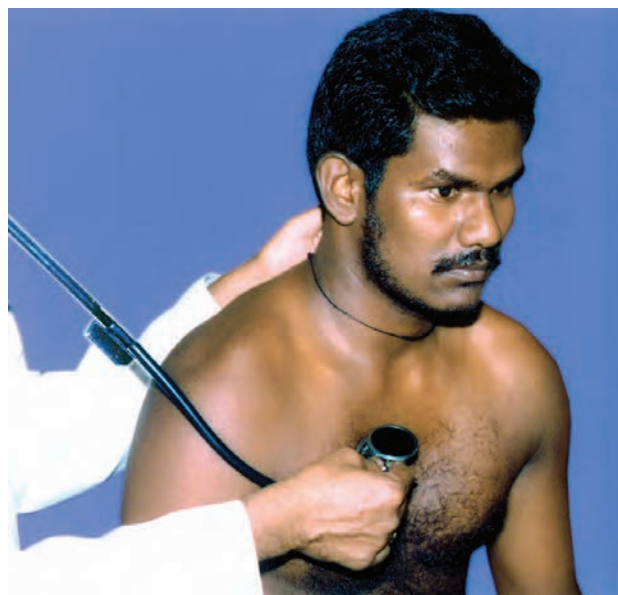

Fig. 3.25: Auscultate with the diaphragm in leaning forward position (for aortic murmurs)

Second heart sound
Clicks
Opening snaps
Tumour plops
Pericardial rubs, knocks
Systolic murmurs
Early diastolic murmurs.

Auscultatory Areas (Fig. 3.26)**Areas of Auscultation over Precordium**

- Mitral area corresponds to cardiac apex.
- Tricuspid area corresponds to the lower left parasternal area.
- Aortic area corresponds to the 2nd right intercostal space close to the sternum.

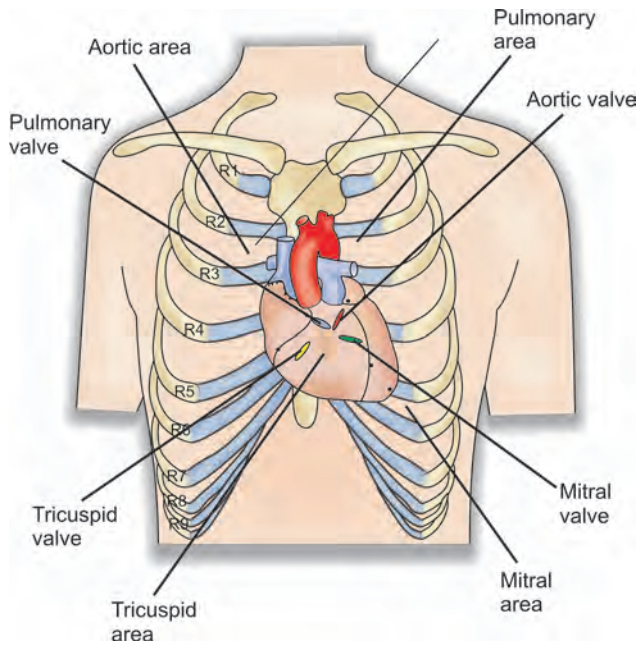

Fig. 3.26: Cardiac valves and auscultatory areas

- Pulmonary area corresponds to the 2nd left intercostal space close to the sternum.
- Erb's area (second aortic area) corresponds to 3rd left intercostal space close to the sternum.
- Gibson's area corresponds to left first intercostal space close to sternum. PDA murmur is best heard here (Gibson's murmur).

Other Areas of Auscultation

Carotids
Inter and infrascapular areas
Axilla
Supra- and infraclavicular areas.

The heart is auscultated for

1. Heart sounds
2. Presence of murmurs
3. Presence of added sounds (S_3 , S_4 , OS, pericardial rub, diastolic knock, tumour plop, prosthetic valve sounds).

Heart Sounds

Heart sounds are defined as relative, brief, auditory vibrations of variable intensity, frequency and quality.

First Heart Sound (S_1)

First heart sound is produced primarily by closure of atrioventricular valves, Mitral (M_1) and Tricuspid (T_1).

Associated vibrations of heart muscles, vessels and adnexal structures are also responsible for production of S_1 on phonocardiogram.

Abnormalities of S_1

S_1 may be soft, loud or variable in intensity.

Soft S_1

Mitral regurgitation
Tricuspid regurgitation
Right or left ventricular dysfunction
Tricuspid stenosis (valve calcification)
Mitral stenosis (valve calcification)
Obesity
Aortic regurgitation—acute
Prolonged PR interval.

Loud S_1

Mitral stenosis: Mitral valve leaflets are kept widely open till the end of diastole as there is a wide pressure gradient across the mitral valve. During ventricular systole, there is a wide excursion and forceful closure (because of a normal LV contraction) of thickened mitral valve leaflets, producing a loud S_1 . Loud S_1 is also due to the summation effect of M_1 and T_1 , as M_1 is delayed.

Tricuspid stenosis
High output states
Short PR interval
Atrial myxoma (rarely).

Prolonged PR interval produces soft S_1 except in Ebsteins anomaly. Short PR interval produces loud S_1 except in Wolff-Parkinson-White syndrome.

Variable S_1

Atrial fibrillation
Extrasystoles
Complete heart block.

Cannon sound

Complete heart block.

Splitting of S_1

Normally the two major components of S_1 audible are the louder M_1 , heard best at the apex, followed by T_1 , heard best at the left sternal border. They are separated by only 20–30 msec and are usually heard only as a single sound in the normal subject.

When apparent splitting of S_1 is audible at the apex, it is usually caused by a combination of mitral valve closure with a preceding atrial sound or subsequent ejection sound.



In right bundle branch block, the onset of right ventricular systole is frequently delayed and T_1 may be heard sufficiently late to be easily recognised as a sound separated from M_1 . The two components are more readily heard if RBBB is present in pulmonary hypertension.



Causes of splitting of S_1

1. RBBB with pulmonary hypertension
2. Left ventricular pacing
3. Ectopic beats and idioventricular rhythms from LV
4. Ebstein's anomaly.



Causes of reverse splitting of S_1

1. Right ventricular pacing
2. Ectopic beats and idioventricular rhythms from RV.

Second Heart Sound (S_2)

Second heart sound is produced by closure of the aortic (A_2) and pulmonary (P_2) valves.

Abnormalities of S_2

Absent S_2

Absent S_2 in old age may be due to absent A_2 or P_2 as occurs in calcific aortic stenosis or chronic emphysema respectively.

Soft S_2

Soft A_2 occurs in calcific aortic stenosis
Soft P_2 occurs in calcific pulmonary stenosis.

Loud S_2

It may be due to either a loud A_2 or P_2 , or a summation of A_2 and P_2 .

Causes of loud A_2

Systemic hypertension
Aortic aneurysm
Syphilitic aortic regurgitation
Atherosclerosis.

Causes of loud P_2

Pulmonary hypertension
Pulmonary artery dilatation.

Causes of summation of A_2 and P_2

Conditions that delay aortic valve closure, or cause early pulmonary valve closure may produce a single loud S_2 , due to the summation effect, when the splitting interval between A_2 and P_2 becomes less than 30 msec.

Causes of delayed A_2

Complete LBBB
Left ventricular outflow tract obstruction
Arteriosclerotic heart disease
Eisenmenger complex.

Causes of early P_2

WPW syndrome.

In Syphilitic AR, A_2 has a tambour quality.

In Atherosclerotic AR, A_2 is ringing.

In Rheumatic AR, A_2 is soft.

Single S_2

Single S_2 may be either due to an absent A_2 or P_2

- | | |
|--------------------------|--|
| i. Absent A_2 | Aortic stenosis
Aortic atresia |
| ii. Absent P_2 | Pulmonary stenosis
Pulmonary atresia
Transposition of great vessels
Tetralogy of Fallot |
| iii. Truncus arteriosus. | |

Splitting of S_2

S_2 is normally split in children and young adults in inspiration.

Normal Intervals

A_2 - P_2 30 ms
 A_2 -OS 30–150 ms

Wide Split S_2

Wide split S_2 may be variable or fixed. It is an enhanced physiological split in that A_2 and P_2 widen further in inspiration.

Wide, variable split may be due to early A_2 or late P_2

<i>Early A_2</i>	Mitral regurgitation Ventricular septal defect Constrictive pericarditis.
<i>Late P_2</i>	Right bundle branch block Left ventricular ectopics Left ventricular pacemakers.

Wide Fixed Split

1. Atrial septal defect (Ostium secundum type)
2. Partial anomalous pulmonary venous connection
3. Right ventricle failure
4. Massive acute pulmonary embolism.

In ASD, there is a wide and fixed split of S_2

Wide due to increased pulmonary hangout interval* (prolonged right ventricular ejection)



Fixed as the septal defect equalizes LA and RA pressures throughout respiratory cycle.

*It is the interval between the crossing over of the pressure between right ventricle and pulmonary artery and the closure of the pulmonary valve.

ASD with Variable Split S_2

Sinus venosus type of ASD or ASD with atrial fibrillation.

Reverse Splitting of S_2

Reverse splitting of S_2 may be due to early P_2 or delayed A_2 .

Early P_2 WPW syndrome (type B)

Delayed A_2 Aortic stenosis (severe)
Hypertrophic cardiomyopathy
Large patent ductus arteriosus
Left bundle branch block
Right ventricle pacemaker
Right ventricle ectopics
Systemic hypertension.

S_2 in Eisenmenger syndrome

VSD—Single loud S_2

PDA—Close split S_2

ASD—Narrow fixed split S_2

Third Heart Sound (S_3)

S_3 is also known as protodiastolic sound or ventricular gallop. S_3 is produced by initial passive filling of the ventricles.

Causes of physiological S_3

Children

Young adults (< 40 years)

Athletes

Pregnancy.

Causes of pathological S_3

High output states

Congenital heart disease—ASD, VSD, PDA

Regurgitant lesions of aortic, mitral, tricuspid valves.

Hypertrophic cardiomyopathy

Ischaemic heart disease

Constrictive pericarditis

Systemic hypertension

Pulmonary hypertension.

Differentiating Features between Right and Left Ventricular S_3

Features	RV- S_3	LV- S_3
Site	Tricuspid area	Mitral area
Accentuation with respiration	On inspiration	On expiration

LV- S_3 may be either physiological or pathological.

RV- S_3 is always pathological.

Differentiating Features between A_2 -OS and A_2 - S_3

Features	A_2 -OS	A_2 - S_3
Interval	30–150 m sec	> 150 m sec
Site	Mid or entire precordial	Apical
Pitch	High	Low
Character	Snapping	Thudding
Associations	Loud S_1 Mid diastolic murmur MS or TS	Normal or soft S_1 Pansystolic murmur MR or TR
Variation on standing	A_2 -OS interval increases	No change

Fourth Heart Sound (S_4)

S_4 is also known as presystolic gallop or atrial gallop.

S_4 is produced by a rapid emptying of the atrium into non-compliant ventricle.

Physiological S_4 is recordable, but inaudible in children and young adults.



Causes of Pathological S_4

Hypertrophic cardiomyopathy

Systemic hypertension

Coronary artery disease

Angina pectoris

Myocardial infarction

Ventricular aneurysm.

S_3 Ventricular distension sound

S_4 Atrial contraction sound.

Gallops

Triple Rhythm with Tachycardia

Triple rhythm is the presence of 3 heart sounds

Atrial gallop S_1, S_2, S_4

Ventricular gallop S_1, S_2, S_3 .

Quadruple Rhythm

Quadruple rhythm is the presence of 4 heart sounds (S_1, S_2, S_3 and S_4).

Summation Gallop

Summation is the presence of S_1, S_2 with merged S_3 and S_4 .



Opening Snap (OS)

OS is produced by opening of atrioventricular valves.

Mechanism

OS is the sound generated due to the sudden early diastolic buckling of anterior mitral or tricuspid leaflet due to elevated left or right atrial pressure.



Causes of Opening Snap (OS)

OS heard over lower left parasternal region

- Tricuspid stenosis (common)
- Tricuspid regurgitation
- ASD.

OS heard just internal to the apex

- Mitral stenosis (common)
- Mitral regurgitation
- VSD
- PDA.

OS is soft or absent in Mitral stenosis (MS) in the following conditions:

1. Mild MS
2. Severe MS (due to extreme clockwise rotation of the heart)
3. Calcific MS
4. Congenital MS
5. MS associated with AS or AR.

In mitral stenosis, OS is best heard in between the mitral and tricuspid areas, with the diaphragm of the stethoscope, with the patient in standing position, and may also be heard all over precordium.

MDM is best heard in the mitral area with the bell of the stethoscope, with the patient in left lateral decubitus position.

Differentiating Features between A_2 -OS and A_2 - P_2

Features	A_2 -OS	A_2 - P_2
1. Site	Best appreciated over the mid precordial area	Best appreciated over the pulmonary area
2. Interval	Long interval (30–150 ms)	Short interval (< 30 ms)
3. Postural variation	Becomes wider on standing	Becomes narrower on standing
4. Variation with respiration	Narrows on inspiration	Widens on inspiration

Ejection Clicks (Vascular/Valvular)

Valvular Clicks

- Ejection clicks are produced by the opening of the semilunar valves
- Aortic ejection click is heard in valvular aortic stenosis
- Pulmonary ejection click is heard in valvular pulmonary stenosis.

Differentiating Features between Aortic and Pulmonary Ejection Clicks

Features	Aortic ejection click	Pulmonary ejection click
Site	Aortic area	Pulmonary area
Conduction	Heard all over precordium	Localised to pulmonary area
Accentuation with respiration	No change with respiration	Intensity increases with expiration

Pulmonary ejection click is the only right sided event which is best heard in expiration and not accentuated in inspiration.

Mid-systolic Clicks

Clicks in mid-systole are heard in

1. Mitral valve prolapse syndrome
2. Tricuspid valve prolapse syndrome
3. Aneurysm of interatrial or interventricular septum
4. Ebstein's anomaly
5. Severe aortic regurgitation.

Vascular Clicks

Vascular click is heard over the aortic area in

- Aortic dilatation
- Systemic hypertension.

Vascular click is heard over the pulmonary area in

- Pulmonary artery dilatation
- Pulmonary hypertension.

Pericardial Knock

It is a loud high frequency diastolic sound heard in constrictive pericarditis due to abrupt halt to the early diastolic filling.

Pericardial Rub

Sounds produced due to sliding of the two inflamed layers of the pericardium. They are scratching, grating



or creaking in character and triphasic (mid-systolic, mid-diastolic and presystolic). They are evanescent and they may vary with time and posture. Rubs are best heard along the left sternal edge in third and fourth spaces.

Pericardial rub may be heard in

1. Viral pericarditis
2. Pyogenic pericarditis
3. Tuberculous pericarditis
4. Acute myocardial infarction
5. Dressler's syndrome
6. Acute rheumatic fever
7. SLE
8. Rheumatoid arthritis
9. Uraemia.

Tumour Plop

It is a diastolic sound heard in right or left atrial myxomas which are mobile and have a long pedicle.

Prosthetic Sounds

Prosthesis type	Acoustic characteristic
Ball valves	Opening sound louder than closing sound
Tilting disc valves	Only closure sound heard
Bileaflet valves	Closure sound well-heard

Mitral prosthesis: The opening sound corresponds to opening snap and closing sound to S_1 .

Aortic prosthesis: The opening sound corresponds to ejection click and closing sound to S_2 .

Heart Murmurs

Heart murmurs are relatively prolonged series of auditory vibrations of variable intensity, quality and frequency. It is due to turbulence that arises when blood velocity increases due to increased flow or due to flow through a constricted or irregular orifice.

Murmurs should be described in the following way:

- a. Area over precordium where murmur is best heard
- b. Whether murmur is systolic or diastolic
- c. Timing and character of the murmur (ESM, PSM, MDM, EDM)
- d. Intensity of the murmur (grading)
- e. Pitch of the murmur (low or high pitched)
- f. Whether the murmur is best heard with the bell or the diaphragm of the stethoscope (MDM is best heard with the bell of the stethoscope, whereas ESM, EDM

and PSM are best heard with the diaphragm of the stethoscope)

- g. Conduction of the murmur
- h. Variation of the murmur with respiration (left sided murmurs are best heard in expiration, whereas right sided murmurs are best heard in inspiration)
- i. Posture in which murmur is best heard (MDM of MS is best heard in the left lateral position and EDM of AR is best heard with the patients sitting and leaning forward and holding his breath in expiration)
- j. Variation of the murmur with dynamic auscultation (manoeuvres, postures, pharmacological agents like amyl nitrite).

Levine and Freeman's Grading of Murmurs

Systolic Murmur

Grade

- I Very soft (heard in a quiet room)
- II Soft
- III Moderate
- IV Loud with thrill
- V Very loud with thrill (heard with stethoscope)
- VI Very loud with thrill (heard even when stethoscope is slightly away from the chest wall).

Diastolic Murmur

Grade

- I Very soft
- II Soft
- III Loud
- IV Loud with thrill.

Systolic Murmurs

Murmurs which occur during any part or the whole of systole (S_1 to S_2) are known as systolic murmurs.

Early Systolic Murmurs

Causes (Fig. 3.27)

- 1 Ventricular Septal Defect
 - a. Very small muscular VSD, or
 - b. Large VSD with pulmonary hypertension.

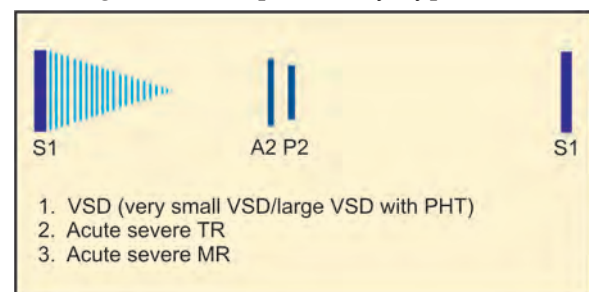

Fig. 3.27: Early systolic murmurs



2. Acute severe tricuspid regurgitation.
3. Mitral regurgitation (acute severe).

**Mid-systolic Murmurs
(Ejection Systolic Murmurs)**

Aortic stenosis (AS) (Fig. 3.28)
 Pulmonary stenosis (PS) (Fig. 3.29)
 Hypertrophic cardiomyopathy (HOCM).

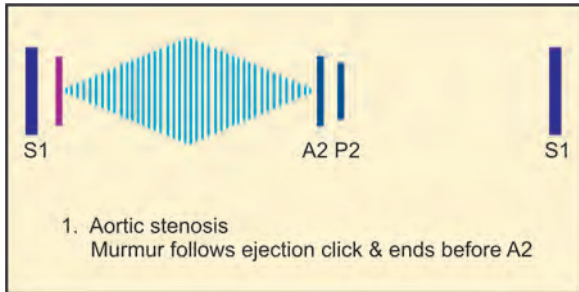

Fig. 3.28: Ejection systolic murmur of AS

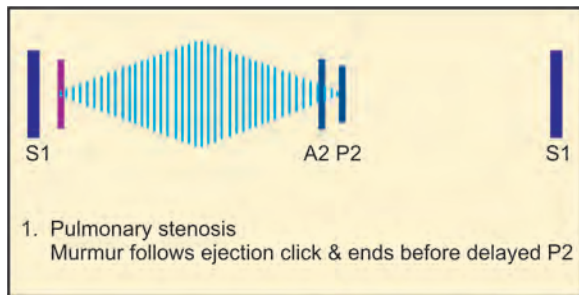

Fig. 3.29: Ejection systolic murmur of PS

Late Systolic Murmurs

Causes (Fig. 3.30)

- Mitral valve prolapse syndrome
- Tricuspid valve prolapse syndrome
- Papillary muscle dysfunction.

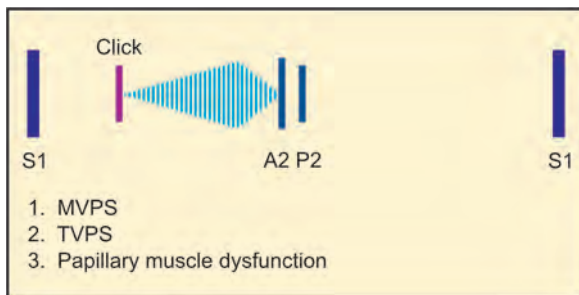

Fig. 3.30: Late systolic murmur

**Differentiating Features between
Valvular AS and PS**

Features	AS	PS
Site	Right 2nd intercostal space	Left 2nd intercostal space
Conduction	To right carotid	To left infraclavicular area
Accentuation with respiration	In expiration	In inspiration
Variation of murmur with valsalva manoeuvre	Murmur becomes soft	Murmur becomes loud
Ejection click	No variation with respiration	Best heard over the pulmonary area, during expiration
P ₂	-	Soft or absent
A ₂	Soft or absent	-
S ₂	Reverse split	Normally or widely split
Associated AR	+	-

In nonvalvular aortic or pulmonary stenosis, the intensity of A₂ or P₂ is normal respectively. Ejection clicks are not heard.

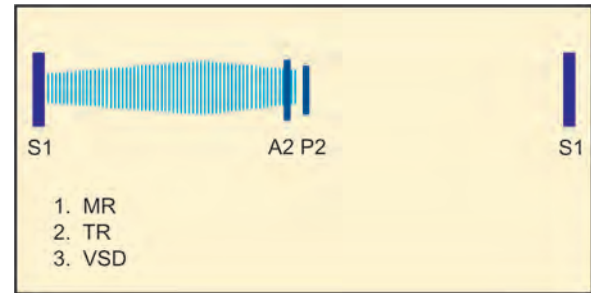

Fig. 3.31: Pansystolic murmur

Pansystolic Murmurs (Fig. 3.31)

- Mitral regurgitation (MR)
- Ventricular septal defect (VSD)
- Tricuspid regurgitation (TR).

- In TR, look for prominent 'v' wave in JVP and systolic hepatic pulsations, in addition.
- Organic TR is always associated with TS.
- In majority of the cases, TR is functional.

Differentiating Features between MR, TR and VSD

Features	MR	TR	VSD
Site	Apex	Left parasternal 5th or 6th intercostal space	Left parasternal 3rd or 4th intercostal space
Conduction	To axilla, base and back	Localised	Localised
Accentuation with respiration	In expiration	In inspiration	In inspiration

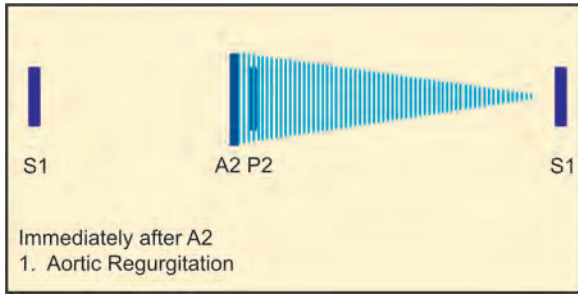

Fig. 3.32: Early diastolic murmur—aortic regurgitation

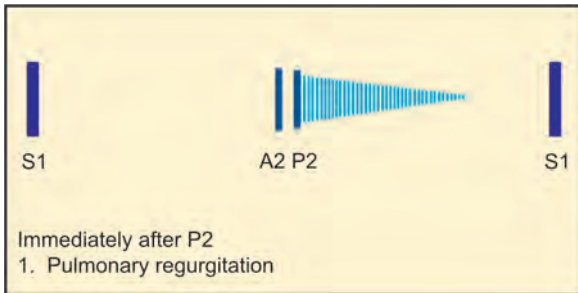

Fig. 3.33: Early diastolic murmur—pulmonary regurgitation

Diastolic Murmurs

Murmurs which occur during any part of diastole (early, mid, or late) are known as diastolic murmurs.

Early Diastolic Murmurs

Causes

Aortic regurgitation (AR) (Fig. 3.32)

Pulmonary regurgitation (PR) (Fig. 3.33).

Differentiating Features between AR and PR

Features	AR	PR
Site	Right 2nd intercostal space and Erbs area	Left 2nd intercostal space
Accentuation with respiration	On expiration	On inspiration

Mid-diastolic Murmurs (Fig. 3.34)

Common causes

- Mitral stenosis
- Tricuspid stenosis.

Uncommon causes

- Carey-Coombs' murmur in acute rheumatic valvulitis
- Austin-Flint's murmur of chronic AR
- Acute severe aortic regurgitation (it is due to the diastolic flutter of the anterior mitral leaflet by the regurgitant blood stream)

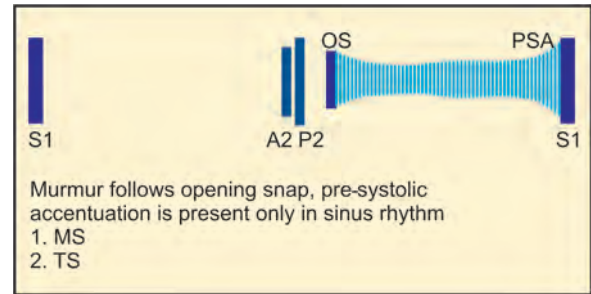

Fig. 3.34: Mid-diastolic murmur

- Ritan's murmur in complete heart block
- Flow mid-diastolic murmurs heard in high output states.
- Organic pulmonary regurgitation.

Flow MDM may be heard across the tricuspid valve on the right side of the heart in the following conditions:

- Atrial septal defect
- Tricuspid regurgitation
- Total anomalous pulmonary venous connection.

Flow MDM may be heard across the mitral valve on the left side of the heart in the following conditions:

- Ventricular septal defect
- Patent ductus arteriosus
- Mitral regurgitation
- Aortic regurgitation.

Late Diastolic Murmurs (Pre-systolic Murmurs)

Causes

- Mitral stenosis
- Tricuspid stenosis
- Atrial myxomas
- Complete heart block.

Continuous Murmurs (Fig. 3.35)

A continuous murmur is one that begins in systole and extends through the second heart sound into part or whole of diastole. It is generated by flow of blood from a zone of high resistance to a zone of low resistance without interruption during both systole and diastole.

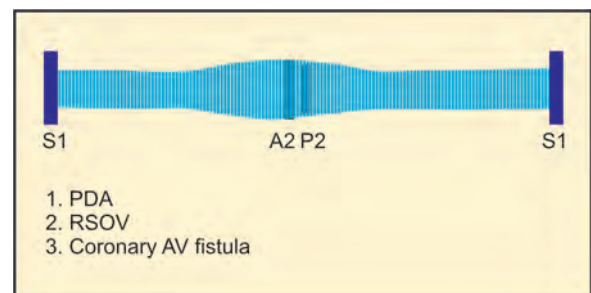

Fig. 3.35: Continuous murmur

**Classification of Continuous Murmurs***High pressure to low pressure shunts*

- a. Systemic to pulmonary communication
 - Patent ductus arteriosus
 - Aortopulmonary window
 - Tricuspid atresia
 - Pulmonary atresia
 - Anomalous origin of left coronary artery from pulmonary artery.
- b. Systemic to right heart connection
 - Coronary arteriovenous fistula
 - Rupture of sinus of Valsalva.
- c. Left atrium to right atrium connection
 - Lutembacher syndrome (atrial septal defect + acquired MS).
- d. Arteriovenous fistulae
 - Systemic
 - Pulmonary.
- e. Venovenous shunts
 - Portasystemic shunts.

Normal flow through constricted arteries

- Coarctation of aorta
- Peripheral pulmonary artery stenosis
- Carotid stenosis
- Coeliac artery stenosis
- Mesenteric artery stenosis
- Renal artery stenosis.

Increased flow through normal vessels

- a. Venous (Diastolic accentuation)
 - Cervical venous hum
 - Umbilical vein (Cruveilhier-Baumgarten murmur).
- b. Arterial (Systolic accentuation)
 - Mammary souffle
 - Uterine souffle
 - Hepatoma
 - Nephroma
 - Thyrotoxicosis.

Approach to Continuous Murmurs

An approach to the differential diagnosis, when a continuous murmur is heard, is done by assessing the following:

1. Presence or absence of cyanosis
2. Type of apical impulse (LV or RV)
3. Site of the murmur
4. Accentuation of murmur (systolic or diastolic phase).

Acyanotic Heart Disease with

1. RV type of apex
 - a. Rupture of sinus of Valsalva into right atrium or right ventricle
 - b. Peripheral pulmonary artery stenosis.

2. LV type of apex
 - a. Patent ductus arteriosus
 - b. Aortopulmonary window
 - c. Rupture of sinus of Valsalva into left ventricle
 - d. Coronary arteriovenous fistula.

Cyanotic Heart Disease with

1. RV type of apex
 - Total anomalous pulmonary venous connection to SVC
2. LV type of apex
 - i. Pulmonary arteriovenous fistula
 - ii. Bronchopulmonary collaterals with
 - a. Tetralogy of Fallot
 - b. Tricuspid atresia
 - c. Truncus arteriosus.
3. Site of the murmur
 - In PDA, continuous murmur is best heard over first and second left intercostal spaces.
 - In aortopulmonary window, continuous murmur is best heard over the third left intercostal space.
 - In rupture of sinus of Valsalva, continuous murmur is best heard over third and fourth left intercostal spaces.

Continuous Murmurs with Systolic Accentuation

1. Patent ductus arteriosus
2. Peripheral pulmonary artery stenosis
3. Bronchopulmonary anastomosis.

Continuous Murmurs with Diastolic Accentuation

1. Rupture of sinus of Valsalva (RSOV)
2. Coronary arteriovenous fistula
3. Anomalous origin of left coronary artery from pulmonary artery (ALCAPA)
4. Pulmonary arteriovenous fistula.

To and Fro Murmurs (Biphasic Murmurs)

A murmur occurring through a single channel and occupying midsystole and early diastole and does not peak around S_2 , e.g. aortic stenosis with aortic regurgitation, pulmonary hypertension with pulmonary regurgitation.

Differentiation between Continuous and To and Fro Murmur

<i>Continuous murmur</i>	<i>To and fro murmur</i>
1. Unidirectional	Bidirectional
2. S_2 engulfed by the murmur	S_2 heard well



Systolico-diastolic Murmur

A murmur that occupies systole and diastole and occurs through different channels and does not peak around S_2 .



Causes

VSD with AR.

Differentiation Between PDA and VSD with AR

Features	PDA	VSD with AR
Heart murmur Site	Continuous 1st and 2nd left intercostal space	Systolico-diastolic 4th left intercostal space
S_2	Engulfed by the murmur	Well-heard
Eddy sounds	Present	Absent

Innocent Murmurs (Fig. 3.36)

Soft systolic murmurs heard in individuals without any cardiac abnormalities. They are due to increased blood flow through the ventricular outflow tracts.

They are short, soft (grade 3/6 or less), systolic murmurs usually heard over supraclavicular area and along the sternal borders.

Innocent murmurs may be heard

1. In children, when it is known as Still's murmur
2. In adults (> 50 years), when it is known as 50/50 murmur, i.e. 50% of adults above 50 years of age may have a systolic murmur.

Functional Murmurs

These are murmurs caused by dilatation of heart chambers or vessels or increased flow.

Systolic Murmurs

Ejection systolic murmur (ESM): ESM may be heard over aortic area in

1. Severe AR
2. Dilatation of aorta.

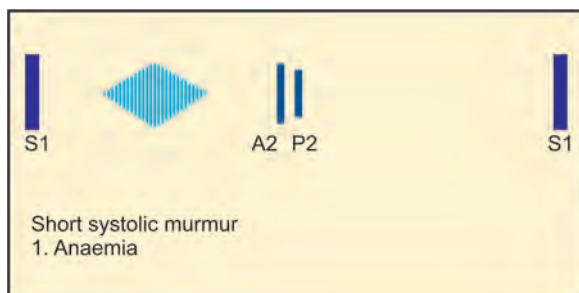

Fig. 3.36: Innocent systolic murmur

ESM may be heard over pulmonary area in

1. Severe PR
2. ASD
3. VSD
4. PDA
5. Dilatation of pulmonary artery.

ESM may also be heard in certain skeletal deformities like pectus excavatum or straight back syndrome.

Pansystolic murmur (PSM): In dilatation of left ventricle or right ventricle, functional PSM of mitral or tricuspid regurgitation may be heard respectively.

Diastolic Murmurs

Mid diastolic flow murmurs: Mid-diastolic flow murmurs may be heard over the mitral or tricuspid areas, the causes of which have already been discussed.

Changing Murmurs

These are murmurs which change in character or intensity from moment to moment, e.g.

- Carey-Coombs' murmur –day to day changes
- Infective endocarditis
- Atrial thrombus
- Atrial myxomas.

Dynamic Auscultation

Dynamic auscultation refers to the changes in circulatory haemodynamics by physiological and pharmacological manoeuvres and about the effect of these manoeuvres on the heart sounds and murmurs.

1. Respiration

Murmurs that arise on the right side of the heart becomes louder during inspiration as this increases venous return and therefore blood flow to the right side of the heart. Left sided murmurs are either unchanged or becomes softer. Expiration has the opposite effect (Left sided murmurs are louder during expiration).

Deep Expiration

The patient leans forward during expiration to bring the base of the heart close to the chest wall and in this posture aortic regurgitant murmur and the scraping sound of a pericardial friction rub are better heard.

2. Valsalva Manoeuvre

In this manoeuvre, patient is advised to close the nose with the fingers and breathe out forcibly with mouth closed against closed glottis. This manoeuvre has 4 phases.

Phase 1: At the beginning, there is rise in intrathoracic pressure and transient increase in left ventricular output.

Phase 2: During straining phase, systemic venous return falls resulting in reduced filling of right and left ventricle. As a result the stroke volume and the BP falls, but the heart rate increases. Most of the cardiac murmurs become softer. However, the systolic murmur of hypertrophic cardiomyopathy becomes louder and the systolic click and the murmur of MVPS begin earlier.

Phase 3: During the release phase, first the right sided and then the left sided cardiac murmurs become louder briefly before returning to normal.

Phase 4: Overshoot of systemic arterial pressure and reflex bradycardia.

3. Standing to Squatting

When the patient suddenly squats from the standing position, venous return and systemic arterial resistance increase simultaneously causing a rise in stroke volume and arterial pressure. Most of the murmurs become louder. However, left ventricular size is increased which reduces the obstruction to outflow and thus the intensity of systolic murmur of hypertrophic cardiomyopathy is reduced, while the midsystolic click and murmur of MVPS are delayed.

Squatting to Standing

When the patient stands up quickly after squatting the opposite changes occur.

4. Isometric Exercise

Sustained hand grip for 20-30 seconds increases systemic arterial resistance, blood pressure and heart size. The systolic murmur of aortic stenosis may become softer because of the reduction in the pressure gradient across the valve, but often remains unchanged. Most other murmurs become louder except systolic murmur of HCM, which is softer and the MVPS murmur is delayed because of the increased ventricular volume.

Dynamic Auscultation

Manoeuvre	HCM	MVPS	AS	MR
Valsalva –phase II	↑	↑ or ↓	↓	↓ or ↔
Hand grip or Squatting	↓	↓	↑	↑
Standing	↑	↑	↓	↓ or ↔
Exercise	↑	↑	↑ or ↔	↓
Amylnitrate	↑↑	↑	↑	↓
Isoproterenol	↑↑	↑	↑	↓

Electrocardiogram

Normal P-wave duration is 0.08 sec to 0.10 sec. Maximum amplitude is 2.5 mm (Figs 3.37 and 3.38).

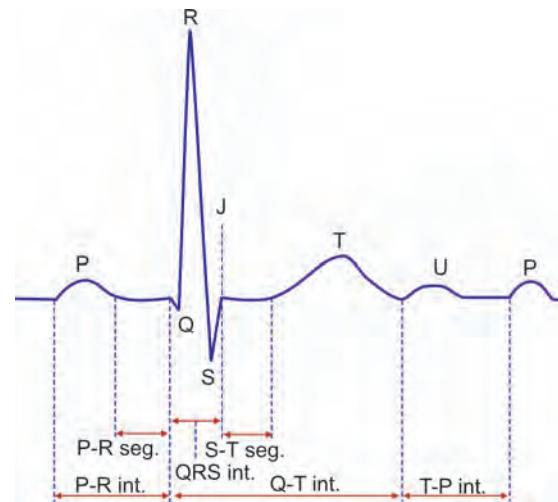

Fig. 3.37: Principal ECG segments and time intervals

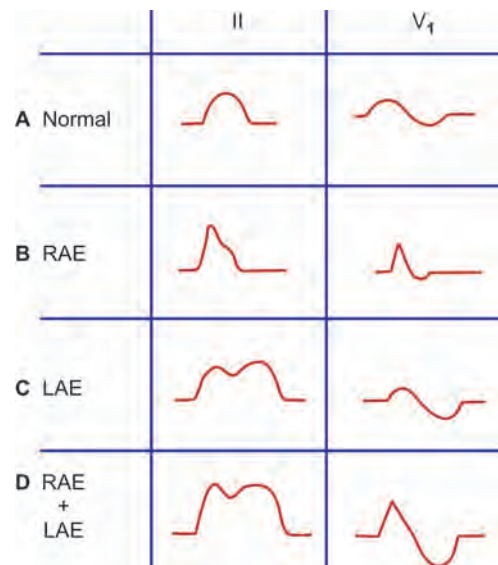

Fig. 3.38: Changes in P-wave morphology

Electrical Axis

Electrical axis must be taken into account for the correct interpretation of the ECG. It is determined from the frontal plane leads – I, II, III, aVR, aVL and aVF. It is quantified by using the hexaxial reference system (Fig. 3.39). The normal QRS axis shows a wide range of normality from -30° to $+90^{\circ}$.

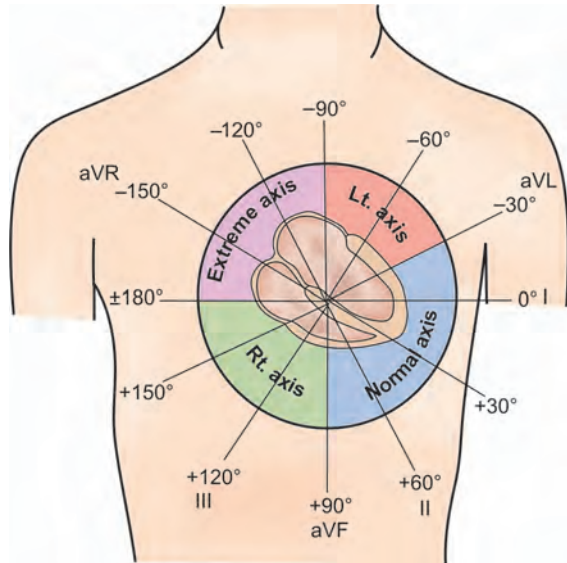

Fig. 3.39: Hexaxial reference system in ECG

If a cardiac vector courses parallel to a particular lead, it will make the greatest impression on that lead and the ECG record will be maximum positive. The same vector records a small and equiphasic complex in the lead which is perpendicular to the previous one. Therefore, to determine the axis locate the frontal plane lead which shows small equiphasic QRS deflexion (least net QRS deflexion), and its perpendicular lead forms the electrical axis of the heart which shows maximum positive QRS deflexion.

It is useful to memorise the paired leads which are perpendicular to each other (Lead I to aVF, lead II to aVL, lead III to aVR). Similar method can be adopted for determining the 'P' wave and 'T' wave axis.

Simple Methods (Not accurate)

- Lead I and II show predominantly positive QRS complex – Normal axis
- QRS complex predominantly positive in lead I and negative in lead III – Left axis
- QRS complex predominantly positive in lead III and negative in lead I – Right axis
- Left axis deviation is more negative than -30°
- Right axis deviation is more positive than $+90^\circ$

Left Atrial Enlargement (Fig. 3.40B)

P mitrale—P-wave is broad and bifid occupying > 0.11 sec in Lead II or biphasic P-wave in V_1 .

Right Atrial Enlargement (Fig. 3.40A)

Tall P-waves of amplitude > 2.5 mm in Lead II (P-pulmonale).

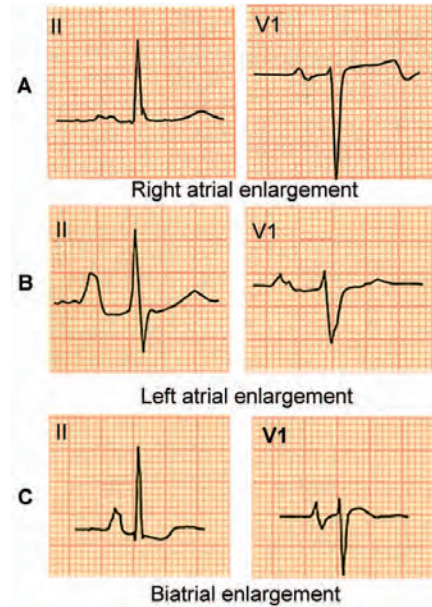

Fig. 3.40: Atrial enlargement

Left Ventricular Hypertrophy (Fig. 3.41)

- Sum of the S-wave in lead V_1 and R-wave in lead V_6 should not exceed 35 mm normally. If it does, it constitutes presumptive evidence of LVH.
- S-wave in V_1 is 20 mm or more in depth.
- R-wave in LI is 20 mm or more in height, or in $V_6 > 25$ mm.
- R-wave in V_6 equals or exceeds the R-wave in V_5 .
- Total QRS voltage in all 12 leads is less than 175 mm in normal. Values greater than 175 mm constitute a good criterion of LVH (Fig. 3.42).
- R-wave in aVL > 13 mm.
- Any R + any S > 45 mm.

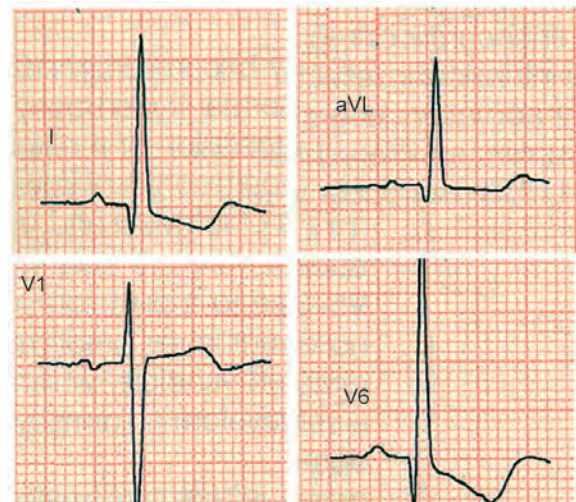

Fig. 3.41: Left ventricular hypertrophy

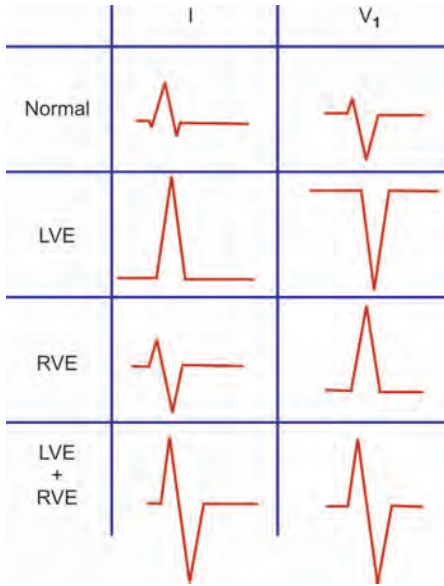

Fig. 3.42: QRS complexes in ventricular enlargement

In LVH due to systolic overload, there is attenuation or disappearance of small initial q-wave in left oriented leads (LI, aVL, V₅, V₆). There may be ST depression and T-wave inversion.

In LVH due to diastolic overload, there are deep narrow q-waves in left oriented leads. There may be tall and symmetrical T-waves in left precordial leads.

Right Ventricular Hypertrophy (Fig. 3.43)

- a. Right axis deviation
- b. Dominant R-waves in right oriented leads. This is often expressed as R : S ratio. If this ratio exceeds 1, RVH is diagnosed
- c. R-wave is > 5 mm in amplitude in V₁

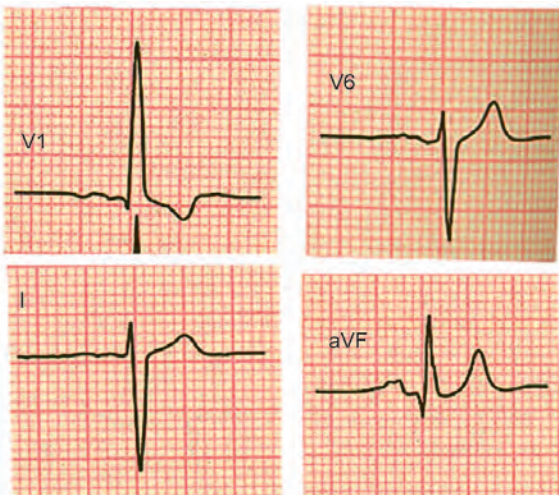

Fig. 3.43: Right ventricular hypertrophy

- d. Dominance of S-wave in left precordial leads
- e. Sum of R-wave in V₁ and S-wave in V₆ is more than 10
- f. Terminal S-waves in all standard leads—SI, SII, SIII syndrome.

Tall R-wave in V₁

- a. RVH
- b. RBBB
- c. WPW (Type A)
- d. Dextrocardia
- e. Posterior wall MI
- f. HOCM.

Biventricular Hypertrophy (Fig. 3.44)

- a. ECG evidence of LVH + Right axis deviation
- b. ECG evidence of LVH + clockwise electrical rotation
- c. ECG evidence of LVH + R : S ratio > 1 in V₁
- d. Large equiphasic QRS in midprecordial leads (Katz-Wachtel phenomenon)
- e. LAE + R : S ratio in V₅ and V₆ < 1 or S-wave in V₅ and V₆ > 7 mm or right axis deviation.

Right Bundle Branch Block (RBBB) (Fig. 3.45)

Complete RBBB

- a. Wide S-wave in LI, V₅ and V₆
- b. In V₁, tall, wide notched R deflection
- c. QRS duration > 0.12 sec in V₁, V₂
- d. Secondary S-T, T changes.

Incomplete RBBB

- a. Diminution of S in V₂ (earliest sign of RBBB)
- b. QRS duration < 0.12 sec.

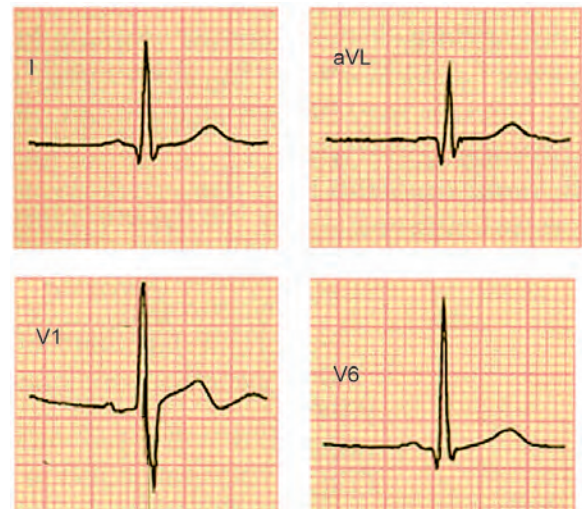

Fig. 3.44: Biventricular enlargement

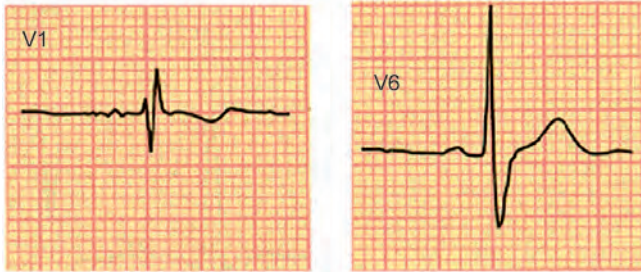

Fig. 3.45: Right bundle branch block

Significance

RBBB may be physiological.

It may also occur with

- Coronary artery disease
- ASD
- Atypical Ebstein's anomaly
- Cardiomyopathy
- Massive pulmonary embolism.

Left Bundle Branch Block (LBBB) (Fig. 3.46)

Complete LBBB

- a. Prolonged QRS duration > 0.12 sec; may be as long as 0.20 sec.
- b. RsR complex or a wide, unnotched complex in aVL
- c. LI, V₅, V₆ show RR or M-shaped complexes
- d. Secondary S-T, T changes opposite in direction to terminal QRS deflection.

Incomplete LBBB

- a. Initial 'q' in V₅ and V₆ disappears and it results in single tall R-wave

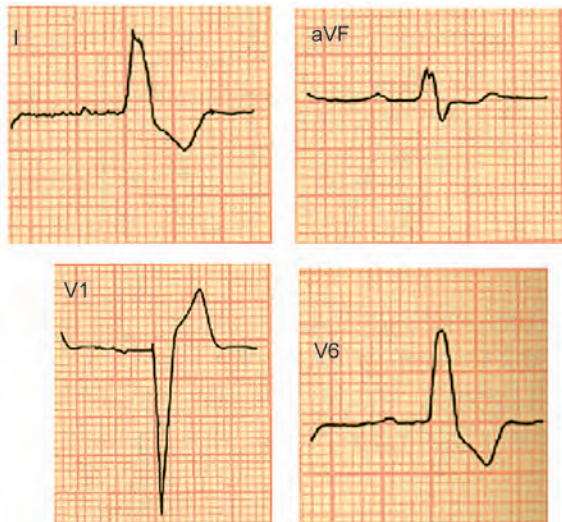

Fig. 3.46: Left bundle branch block

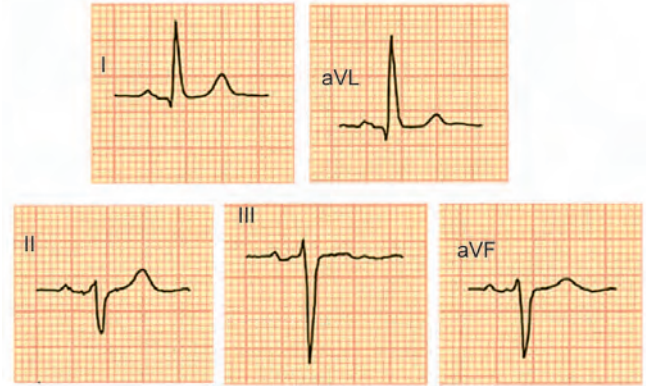

Fig. 3.47: Left anterior fascicular block

- b. Small initial 'r'-wave of rS complex in V₁ disappears and it results in a QS complex.

Significance

LBBB indicates organic heart disease. It is commonly seen in IHD or hypertensive heart disease.

Hemiblocks (Fascicular Blocks)

Left Anterior Hemiblock (LAHB)

Causes

- Coronary artery disease
- Cardiomyopathy
- Longstanding systemic hypertension
- Longstanding CCF
- May be due to MI (divisional peri-infarction block).

ECG Features (Fig. 3.47)

1. Left axis deviation
2. rS complex in lead II; No terminal r or R-wave as in inferior wall MI
3. Lead I and aVL may reflect a prominent initial q-wave followed by a tall ensuing R-wave
4. Lead aVR may reflect a late, slurred terminal r-wave
5. Lead V₅ and V₆ show no initial q-waves which are normally seen. There is attenuation of R-waves and prominence of S-waves in these leads
6. T-waves are in opposite direction to the main QRS deflection.

LAHB when occurs in association with RBBB, it usually indicates a poor prognosis and may lead to complete AV block. When it occurs with LBBB, prognosis is worse.

Left Posterior Hemiblock (LPHB)

Occurrence of LPHB is very rare.

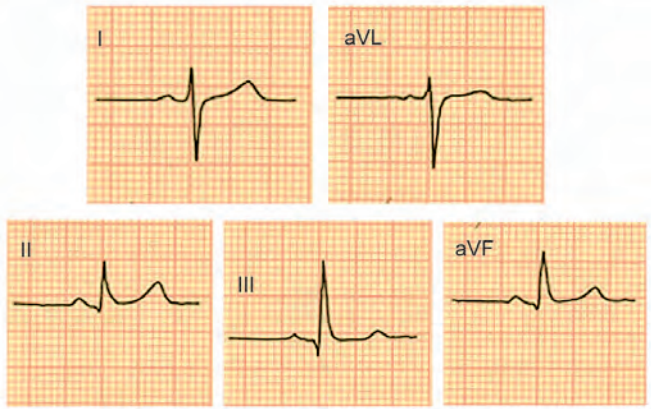

Fig. 3.48: Left posterior fascicular block

ECG Features (Fig. 3.48)

1. Right axis deviation
2. Prominent small initial q-waves in lead II, III and aVF; and a small initial r-wave in standard lead I
3. The distal limb of the tall R-wave in lead III is notched or slurred
4. Low to inverted T-waves in leads II, III and aVF and upright T-waves in lead I.
LPHB with sinus tachycardia may denote pulmonary embolism.

Bi-fascicular Block (Fig. 3.49)

It is the combination of RBBB and left bundle hemiblock (manifest as an axis deviation, e.g. LAD in left anterior hemiblock).

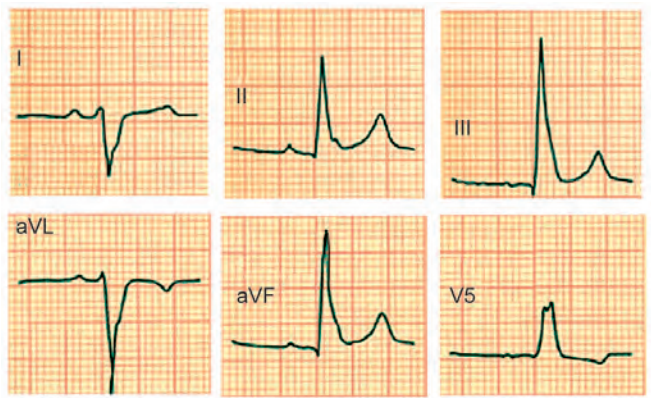

Fig. 3.49: Bi-fascicular block (RBBB + LPHB)

Tri-fascicular Block (Fig. 3.50)

It is the combination of bi-fascicular block and first degree heart block.

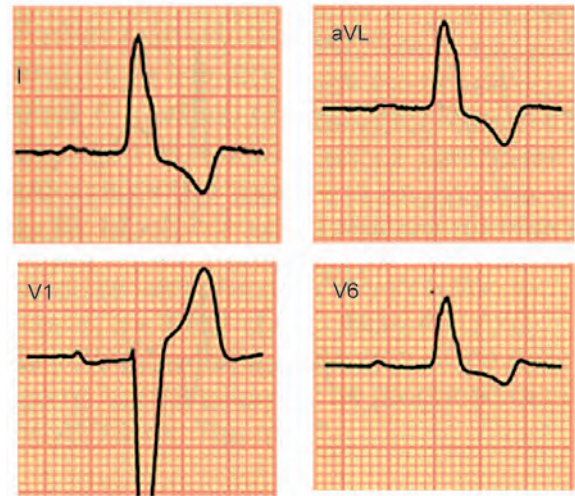

Fig. 3.50: Tri-fascicular block (first degree heart block + LBBB)



Causes of ST Segment Elevation

1. Coronary vasospasm (Prinzmetal’s angina)
2. Organic stenosis of coronary arteries (MI)
3. LV aneurysm
4. Pericarditis (elevated concave upwards S-T segment associated with tall, peaked T-waves and no reciprocal changes in the opposite leads)
5. Early repolarisation.



Causes of S-T Segment Depression

1. In coronary insufficiency
 - a. Horizontal S-T Segment (earliest sign)
 - b. Upward sloping S-T segment depression (It may be a physiological change also. A hypothetical parabola joining the distal limb of the P-wave, the P-R segment, the S-T segment and the proximal limb of the T-wave will be smooth and unbroken in physiological junctional S-T segment depression, whereas the parabola is broken in abnormal junctional S-T segment depression)
 - c. Plane S-T segment depression
 - d. Downward sloping S-T segment depression (This reflects a severe form of impaired coronary blood flow).
2. Hypokalaemia
3. Hypothermia
4. Tachycardia
5. Hyperventilation
6. Anxiety



7. Post-prandial, cold drinks
8. MVP
9. CVA
10. Smoking
11. Pheochromocytoma
12. Digoxin therapy
13. RBBB and LBBB.

ECG in Coronary Artery Disease (Fig. 3.51)

Myocardial Necrosis

This is by the appearance of pathological Q-waves (depth of the Q-wave is more than 25% of the height of succeeding R-wave and its width is more than 0.04 sec.) This may also manifest as QS complexes.

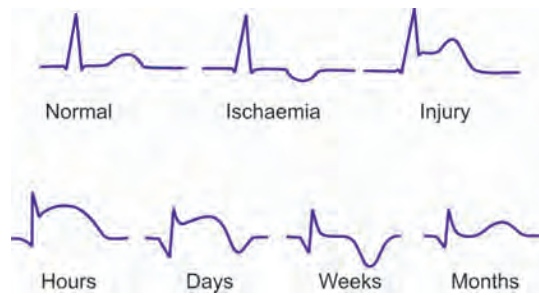

Fig. 3.51: ECG changes in coronary artery disease

Myocardial Injury

This is characterised by S-T segment elevation on the ECG. An elevation of > 1 mm is significant.

Myocardial Ischaemia

This is characterised by inverted, symmetrical, pointed and sometimes deep T-waves.

Localisation of MI

Left Ventricular Infarct

- a. Extensive anterior wall MI (Fig. 3.52)—LI, aVL and precordial leads.
- b. Anteroseptal wall MI—V₁ to V₄
- c. Anterolateral wall MI—LI, aVL, V₄, V₅, V₆
- d. Apical wall MI—V₅, V₆
- e. Inferior wall MI (Fig. 3.53)—LII, LIII and aVF
- f. Inferolateral wall MI—LII, LIII, aVF, V₅ and V₆.

Right Ventricular Infarct (Fig. 3.54)

- a. This is suspected in the setting of acute inferior wall infarction. There is an elevated S-T segment (of

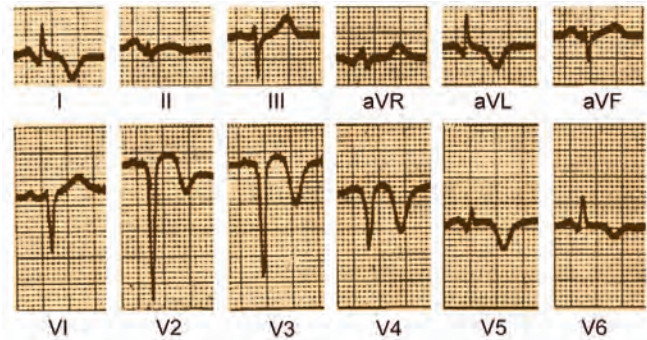

Fig. 3.52: Extensive anterior wall MI

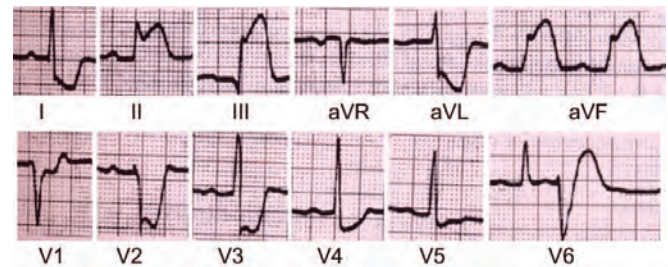

Fig. 3.53: Hyperacute inferior wall MI

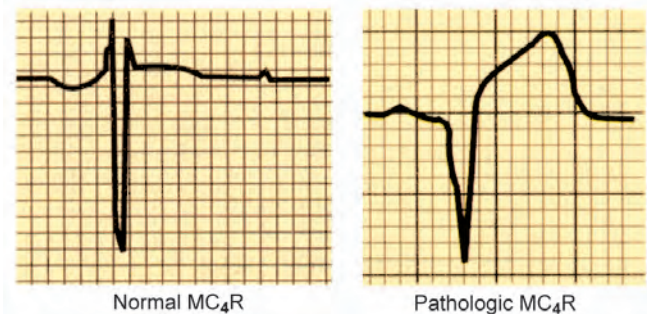

Fig. 3.54: Right ventricular MI

- 1 mm) in extreme right oriented leads V₁ and V₄R (to V₆R).
- b. There is failure of reciprocal S-T segment depression in the right precordial leads in cases of inferior wall MI.

True Posterior Wall Infarct (Fig. 3.55)

Right precordial leads V₁ to V₃, especially lead V₂, reflect the inverse change or mirror image of a classic anterior wall MI, i.e.

1. Mirror image of QS complex is reflected by a tall and slightly widened R-wave.
2. Mirror image of the coved and elevated S-T segment is reflected by a depressed, concave upward S-T segment. Usually, this change is not seen.

3. Mirror image of inverted, symmetrical T-wave is reflected by an upright, widened and usually tall T-wave. Diagnosis of true posterior wall MI should not be entertained without this change.

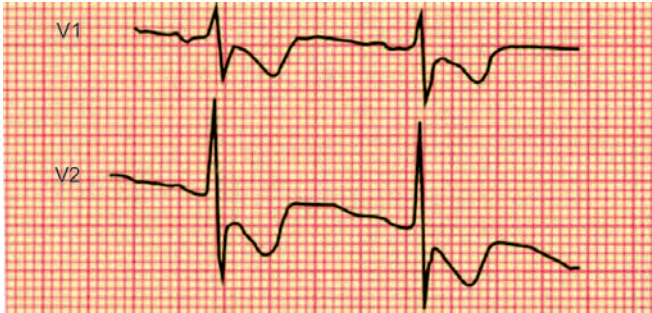

Fig. 3.55: Posterior wall MI

Subendocardial Infarct

ECG presents with ST depression and deeply inverted T-waves in the mid-precordial and lateral precordial leads as well as in I and LII. These changes persist for several days (mirror image of epicardial infarction).

MI with LBBB

It is very difficult to detect the presence of MI in the presence of associated LBBB (Fig. 3.56).

The various ECG signs that are proposed for diagnosis of acute MI in the presence of LBBB are:

1. ST segment elevation > 1 mm and concordant with QRS complex
2. ST segment depression > 1 mm in leads V₁V₂ (or) V₃
3. ST segment elevation > 5 mm and discordant with QRS complex
4. Presence of Q-waves in two contiguous precordial leads or in two limb leads
5. Left axis deviation > -30°
6. R-wave regression from V₁-V₄
7. QS pattern from V₁-V₄
8. Terminal S-wave in V₅ or V₆
9. Positive T-waves in V₅ or V₆

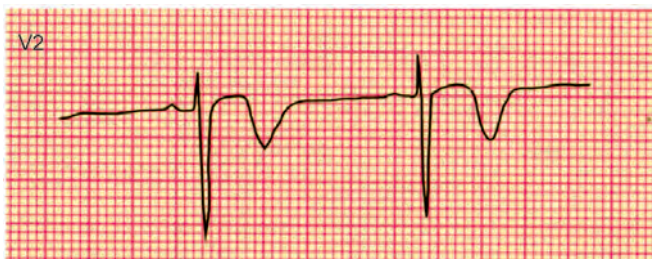

Fig. 3.56: Non-Q-wave MI (non-ST elevation MI)

10. Notching > 0.05 sec. in the ascending limb of S-wave in V₃ or V₄ (*Cabrera's sign*)
11. Notching > 0.05 sec in the ascending limb of R-wave in LI, aVL, V₅ (or) V₆ (*Chapman's sign*).

* Infarct pattern is not masked in LII, LIII, aVF and premature beats.

MI with RBBB

The presence of RBBB does not interfere with the diagnosis of associated MI.

Acute Pericarditis (Fig. 3.57)

ECG shows

- Sinus tachycardia
- An elevated, concave upwards S-T segment
- Upright, tall, peaked T-waves (earliest change)
- No reciprocal changes in the opposite leads.

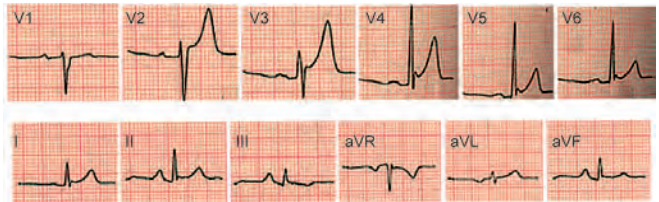

Fig. 3.57: Pericarditis

Pericardial Effusion (Fig. 3.58)

ECG shows

- Low to inverted T-waves in most leads
- Low voltage complexes (Voltage of QRS is < 5 mm in limb leads and < 10 mm in chest leads)
- Potential electrical alternans.

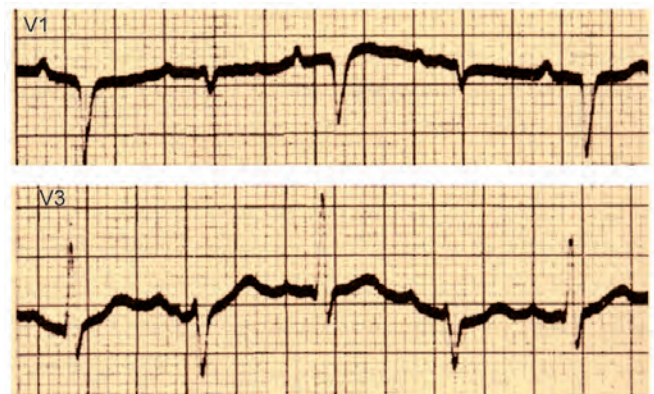

Fig. 3.58: Pericardial effusion



Causes of Low Voltage Complexes

- Obesity
- Thick chest wall
- Global ischaemia
- Cardiomyopathy



Hypothyroidism
Hypopituitarism
Hypothermia
Emphysema.

Amyloid heart disease
Pericardial effusion
Incorrect standardisation

Electrical Alternans

Electrical alternans is an ECG manifestation in which there is alternation in the amplitude of QRS complexes and/or the T-waves. It often accompanies fast rates. When found with slow rates, it indicates left ventricular failure. This is occasionally seen in pericardial effusion.

When pulsus alternans is also present in addition to electrical alternans, it is said to be complete. When electrical alternans is in isolation, it is said to be incomplete.

ECG in Electrolyte Imbalance

Hyperkalaemia

1. Absent P-wave
2. Widening of QRS complex
3. A bizarre, intraventricular conduction disturbance
4. Tall, peaked T-waves (Fig. 3.59)
5. Disappearance of the ST segment.

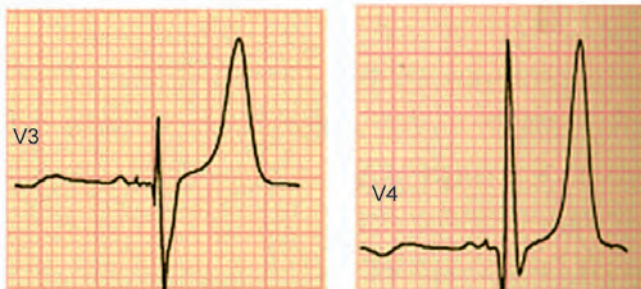

Fig. 3.59: Hyperkalaemia (peaked T-waves)

Hypokalaemia (Fig. 3.60)

1. Disappearance of T-wave
2. Progressive increase in the amplitude of U-wave
3. First and second degree AV block
4. ST segment depression.

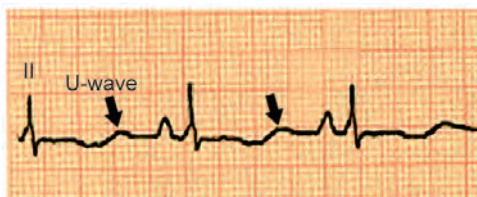

Fig. 3.60: Hypokalaemia

Hypermagnesaemia

ECG findings are similar to hyperkalaemia.

Hypomagnesaemia

ECG findings are similar to hypokalaemia.

Hypocalcaemia (Fig. 3.61)

Prolonged QT interval (due to an increase in duration of ST segment). QT prolongation is inversely proportional to serum calcium level. T-waves are normal.

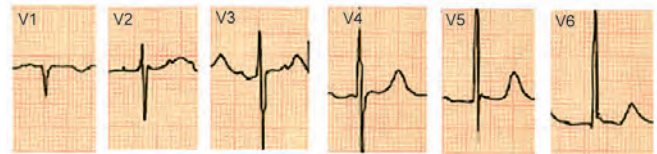

Fig. 3.61: Hypocalcaemia (prolonged QT interval 0.43S)

Hypercalcaemia

Shortening of QT interval (due to shortening of ST segment). T-waves may also become flattened or inverted.

Uraemia

ECG findings are similar to hypocalcaemia and hyperkalaemia (prolonged QT interval + tall, peaked T-waves).



Causes of Tall Symmetrical T-waves

1. Acute subendocardial ischaemia, injury or infarct
2. Recovering inferior wall MI
3. Hyperacute anterior wall MI
4. Prinzmetal angina
5. True posterior wall MI
6. Hyperkalaemia.

Absent P-waves

1. Atrial fibrillation
2. Sinoatrial arrest or block
3. Nodal rhythm
4. Hyperkalaemia.

Inverted 'P' in LI

1. Nodal rhythm
2. Dextrocardia
3. Reversed limb leads.

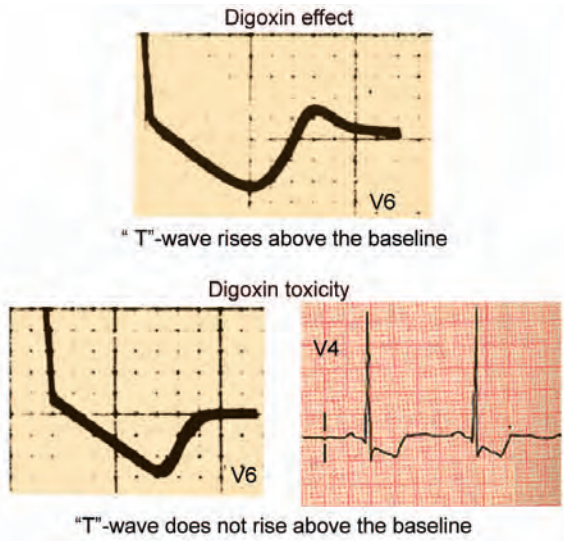

Fig. 3.62: Digoxin effect and toxicity

ECG Changes with Drug Intoxication

Digoxin Effect (Fig. 3.62)

1. ST depression and T-wave inversion in V_5 , V_6 (inverted check mark sign)
2. Short $Q-T_c$ interval
3. Bradycardia, PAT, PAT with block, ventricular extrasystoles, bigeminy, ventricular tachycardia, ventricular fibrillation, 1st, 2nd (Wenkebach type) and 3rd degree heart blocks.

Bundle branch blocks and Mobitz type II second degree AV block are never a complication of digoxin toxicity (Fig. 3.62).

Quinidine Effect (Fig. 3.63)

1. Prolongation of the QT interval and PR interval
2. Prolongation of the QRS complex (LBBB or RBBB may be associated)
3. Occasional ST segment depression
4. Torsades de pointes.

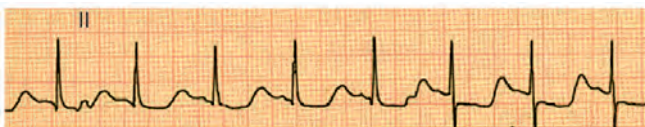

Fig. 3.63: Quinidine effect (Prolonged QT interval)



Causes of Prolonged QT_c Interval (Normally, QT interval is less than 50% of RR interval)

1. During sleep
2. Hypocalcaemia

3. Acute myocarditis
4. Acute MI
5. Quinidine effect
6. Procainamide effect
7. Tricyclic and tetracyclic antidepressant drugs, phenothiazines
8. Cerebral injury
9. Hypothermia
10. HOCM
11. Advanced or complete block, with torsades de pointes
12. The Jervell-Lange-Nielsen syndrome (congenital deafness, syncopal attacks and sudden death)
13. The Romano-Ward syndrome (no deafness)
14. Hypothyroidism
15. MVP
16. Pulmonary embolism
17. Increased ICT.

The prolonged Q-T syndromes are characterised by a prolonged QT interval on the ECG, ventricular arrhythmias, and sudden death especially in the familial long Q-T syndromes.

The QT_c interval in familial long Q-T syndromes ranges from 0.40–0.60 sec., whereas it is 0.38–0.47 sec. in the non-familial conditions.



Causes of Shortened QT_c Interval

1. Digitalis effect
2. Hypercalcaemia
3. Hyperthermia
4. Vagal stimulation.

ECG in Acute Pulmonary Embolism (Fig. 3.64)

In addition to sinus tachycardia

1. Low voltage deflections
2. $S_1 Q_3 T_3$ pattern (Prominent S in lead I, Q in lead III and inverted T in lead III)
3. Right axis deviation
4. RBBB

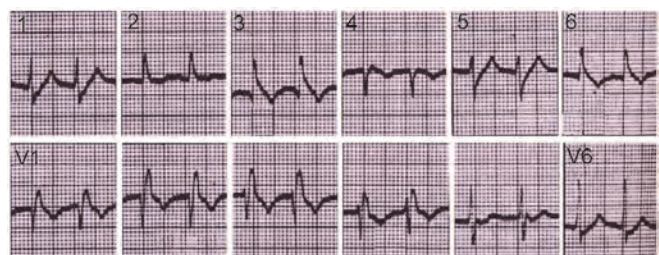

Fig. 3.64: Acute pulmonary embolism



5. ST segment depression or a staircase ascent in lead I and II
6. ST segment elevation or depression in left precordial leads
7. Prominent S in V_6
8. T inversion in right precordial leads
9. P-pulmonale
10. Sinus tachycardia alone.

ECG Features of COPD (Fig. 3.65)

1. Low voltage complexes
2. RVH (Right axis deviation, RBBB and prominent S in V_5 , V_6)
3. P-pulmonale
4. Prominent terminal S-waves in leads I, II and III (SI, SII, SIII syndrome)
5. Non-progression of R-waves in precordial leads.

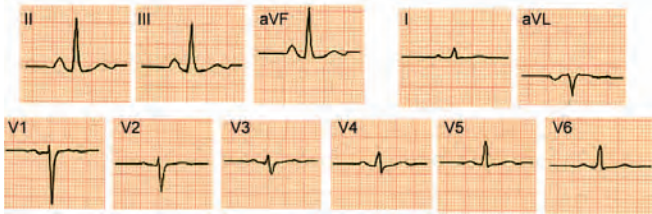

Fig. 3.65: COPD 'P'-pulmonale, poor 'R'-wave progression

ECG Features of Hypothermia (Fig. 3.66)

It is characterised by J-wave or junctional wave, a hump like deflection which occurs at the junction of the distal limb of QRS complex with the S-T segment. There is a delay in the inscription of the intrinsicoid deflection (> 0.06 sec), that might be an early sign of impending VF.

Sinus bradycardia and prolonged QT interval may also occur.

J-wave is also known as 'Osborne' wave.

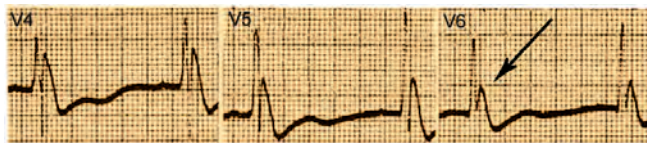

Fig. 3.66: Hypothermia (Osborn waves)



Causes of Pathological Q-wave

1. Transmural MI
2. HOCM
3. WPW syndrome
4. Cardiac contusion and myocarditis
5. Amyloid heart

6. Anomalous origin of coronary arteries
7. Racial.

ECG in Various Arrhythmias

I. Tachyarrhythmias

Tachyarrhythmias are defined as heart rhythms with a rate in excess of 100 beats per minute. These arrhythmias can further be classified into supraventricular tachycardia (origin above the bifurcation of bundle of His) and ventricular tachycardia (Fig. 3.67).

When the origin of impulse is not traced these arrhythmias can be classified morphologically into narrow complex tachycardia (duration of QRS < 120 msec, i.e. 3 small squares) and wide complex tachycardia (duration of QRS > 120 msec).

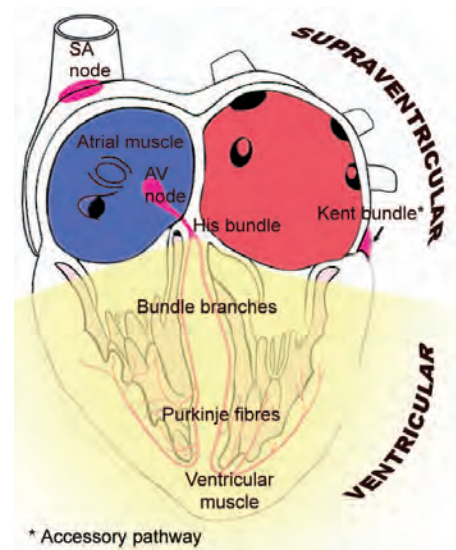

Fig. 3.67: Classification of arrhythmias (based on origin)

Analysis of ECG

- Frequency, morphology and regularity of 'P' waves
- Look for sinus 'P' wave/Ectopic P'2 deflection/Flutter wave/Fibrillation wave
- Relationship between atrial and ventricular activity
- QRS morphology during sinus rhythm/tachyarrhythmia
- Response to carotid sinus massage/vagal manoeuvres.

Rule of Hundreds for Tachycardias

The rule refers to atrial rate.
Atrial tachycardia— 200 ± 50

Narrow Complex Tachycardia (SVT)

	<i>P-wave</i>			<i>QRS- Complex</i>		
	<i>Rate</i>	<i>Contour</i>	<i>Rhythm</i>	<i>Rate</i>	<i>Rhythm</i>	<i>Contour</i>
Sinus tachycardia	100-180	Normal/Peaked	Regular	100-180	Regular	Normal
Atrial flutter	250-350	Saw-toothed	Regular	75-175	Regular except drugs/disease	Normal
Atrial fibrillation	400-600	Absent 'P' with 'f' waves	Irregular	100-160	Irregularly irregular	Normal
Atrial tachycardia with block	150-250	Abnormal 'P' waves	Regular or may be irregular	75-200	Regular except drugs/disease	Normal
AVNRT	150-250	Retrograde 'P'/merged	Regular except onset/termination	150-250	Regular except onset/end	Normal
AVRT	150-250	Retrograde 'P'/merged	Regular except onset/termination	150-250	Regular except Onset/end	Normal
Non-paroxysmal AV junctional tachycardia	60-100	Normal	Regular	70-130	Regular	Normal

Atrial flutter— 300 ± 50

Atrial fibrillation— 400 ± 50

Ventricular tachycardia has the same range as atrial tachycardia— 200 ± 50 , but usually has a rate on the slower side.

A. Paroxysmal Supraventricular Tachycardia

Electrophysiological studies have demonstrated that reentry is responsible for the majority of SVT. Anatomical site has been localized to the sinus node, atrium, AV node or a macroentry circuit involving AV node and AV bypass tract. The mechanism of PSVT can be traced on the basis of RP interval, the time interval between the peak of an R-wave and the subsequent P-wave during tachycardia (Fig. 3.68).

1. Short R-P tachycardia

They have an R-P interval that is less than 50% of the RR interval. These include:

a. *Typical AV nodal re-entrant tachycardia (AVNRT):*

It occurs in patients who have functional dissociation of the AV node into 'slow' and 'fast' pathways. Conduction proceeds antegradely down the slow pathway and retrograde conduction up the fast pathway resulting in atrial and ventricular excitation concurrently. P-waves are hidden within the QRS complexes and can be distinguished only by the comparison of QRS morphologies in tachycardia and in sinus rhythm.

b. *Orthodromic AV re-entrant tachycardia (O-AVRT):*

It is an accessory pathway mediated re-entrant

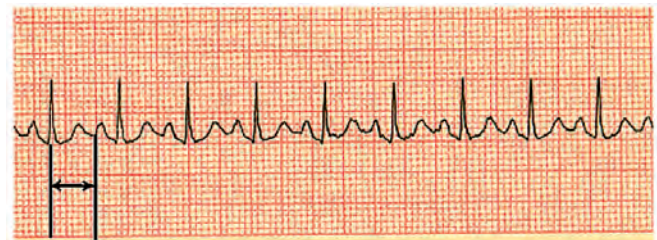

Long R-P tachycardia

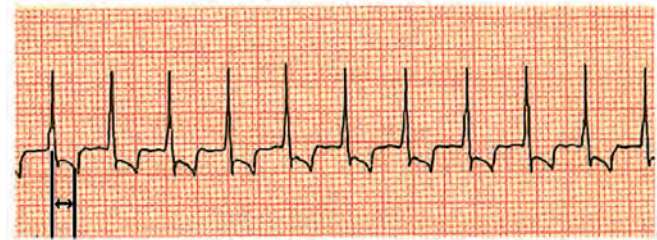

Short R-P tachycardia

Fig. 3.68: RP interval

rhythm. (Anterograde conduction to the ventricle through the AV node and retrograde conduction to the atrium through the accessory pathway. P-waves are seen shortly after QRS complexes (Fig. 3.69).

c. *Sinus tachycardia or ectopic atrial tachycardia with first degree AV block*

d. *Junctional tachycardia:*

It is a narrow-complex tachycardia arising from the AV junction. The impulse is conducted to the atrium and ventricle simultaneously and the P-wave is not easily discernible. It is seen in acute MI, mitral/aortic valve surgery or digitalis toxicity.

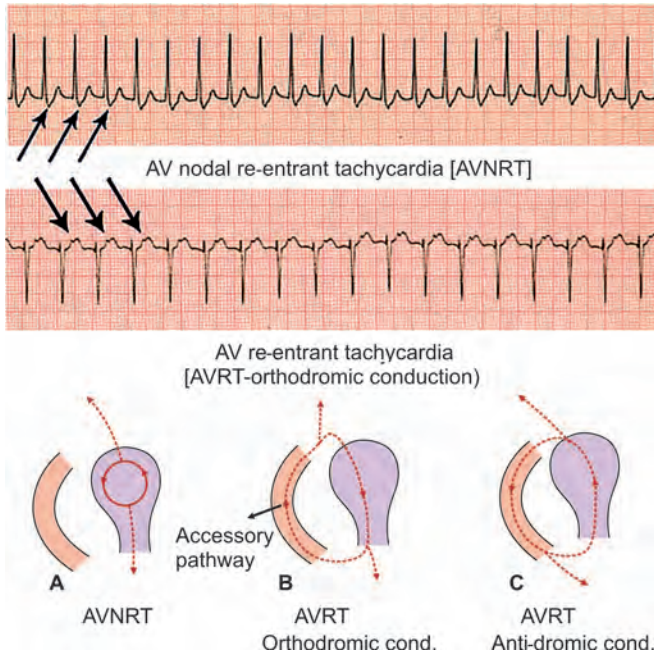

Fig. 3.69: Mechanisms in PSVT



Fig. 3.70: Paroxysmal atrial tachycardia with 2:1 AV block

2. Long R-P Tachycardia

They have an RP interval that is greater than 50% of the RR interval.

- a. Sinus tachycardia or ectopic atrial tachycardia with normal PR intervals.
- b. 'Atypical' AVNRT: Anterograde conduction proceeds over the fast AV nodal pathway and the retrograde conduction over the slow AV nodal pathway in patients with dual AV nodal physiology. Because of the slow retrograde conduction P-wave is well seen after the QRS complex (Fig. 3.70).
- c. O-AVRT mediated by an accessory bypass tract with slow or decremental conduction properties.

3. WPW Syndrome

Pre-excitation is as a result of anterograde activation of the ventricle via an accessory pathway as well as the AV node, resulting in a short PR interval with a delta wave slurring the upstroke of the QRS complex (Fig. 3.71). The presence of accessory pathway predisposes the individuals for SVT (narrow complex orthodromic AVRT).

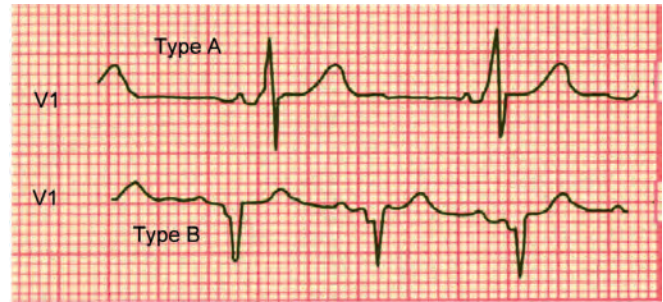

Fig. 3.71: Wolf-Parkinson-White syndrome

- a. Antidromic AVRT: (5% of patients with WPW) The conduction to the ventricle proceeds down the accessory pathway and the retrograde conduction through the His-Purkinje system and the AV node to the atria.
- b. Atrial fibrillation: Atrial fibrillation in patients with WPW syndrome may facilitate rapid ventricular response since the accessory pathway has no decremental properties and ultimately VF.

4. Multifocal Atrial Tachycardia (Fig. 3.72)

Multifocal atrial tachycardia is revealed by 3 or more varying 'P' wave morphologies with irregular QRS complexes. This tachycardia is commonly seen in COPD patients especially when on theophylline therapy.



Fig. 3.72: Multifocal atrial tachycardia

5. Atrial Tachycardia with Complete Heart Block

This is often a manifestation of digoxin toxicity unless proved otherwise.

B. Atrial Flutter (Fig. 3.73)

It is as a result of single re-entrant circuit around functional or structural (scar due to prior cardiac surgery) conduction barriers within the atria. Flutter waves are negative in inferior leads (II, III and aVF) and

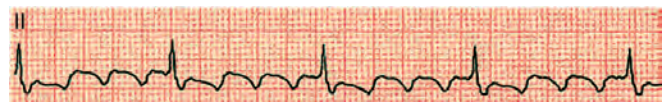

Fig. 3.73: Atrial flutter

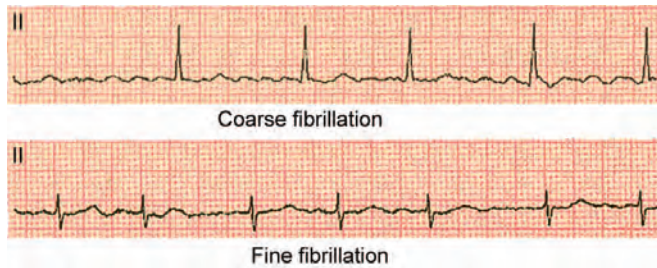

Fig. 3.74: Atrial fibrillation

positive in V_1 with 'sawtooth' appearance. Atrial rate is usually 300 beats/minute with 2:1 or varying conduction to the ventricle.

C. Atrial Fibrillation (Fig. 3.74)

It is the most common sustained tachyarrhythmia seen in many patients.

Common Causes

- 10% of elderly > 75 years
- Lone AF - < 65 years (normotensive with normal heart)
- Valvular heart disease
- Hypertensive heart disease
- Coronary artery disease
- Myocarditis and cardiomyopathy
- Cardiac surgery
- Hypothyroidism
- Hyperthyroidism
- Pheochromocytoma
- Pericarditis

Atrial rate is 400-600/minute with an irregularly irregular rapid ventricular response (> 100 beats/minute).

The ECG is characterised by irregular baseline with no discernible P-waves. The AF waves may be either fine (AF of recent onset) or coarse (AF of long standing duration) The RR interval is irregularly irregular. The RR interval may be deceptively regular and slow in patients with complete heart block, either due to conduction system disease or digoxin toxicity.

Symptoms of AF (Due to rapid ventricular rate):

- Acute pulmonary oedema
- Syncope
- Angina
- Palpitations
- Thromboembolic (cerebral, peripheral, renal, coronary).

Prolonged episodes of rapid ventricular rate may cause a tachycardia mediated cardiomyopathy.



Management of Narrow Complex Tachycardia (SVT)

Initial therapy of acute episodes of narrow complex tachycardia includes hospitalisation, administration of oxygen, establish IV line, vagal manoeuvres such as Valsalva manoeuvre, carotid massage with caution (avoid in the presence of carotid bruit, acute ischaemia and digoxin toxicity) and if it fails, administer IV bolus either one of the short acting drugs that slow or block AV nodal conduction.

- Adenosine (Drug of choice) 6 mg IV and repeat if necessary every 2 minutes using 12 mg or
- Metoprolol 5 mg IV every 5 minutes
- Verapamil 5 mg IV (over 3 minutes) and repeat after 15-30 minutes
- Diltiazem 0.25 mg/kg over 3 minutes and repeat the bolus after 30 minutes
- Esmolol 40 mg IV over one minute followed by IV infusion 4 mg/minute and titrated upto 12 mg/minute
- Digoxin maximum IV dose 0.5 mg over 3 minutes and repeat if needed once.
- Amiodarone IV infusion 300 mg over one hour
- Over-drive pacing.

Use the above drugs in the absence of following adverse signs:

- Hypotension – BP < 90 mm Hg
- Acute severe chest pain
- Heart failure
- Altered conscious level
- Heart rate > 200 bpm

In the presence of above adverse signs- give sedation and synchronised cardioversion.

Synchronised Cardioversion

- 100 J – 200 J – 300 J
(If refractory or to maintain sinus rhythm use)
- Amiodarone 150 mg IV over 10 minutes and then 300 mg over one hour

Chronic therapy of SVT: (use either one of the drugs)

- Diltiazem sustained release 120-360 mg PO qd
- Verapamil sustained release 120-480 mg PO qd
- Metoprolol 25-100 mg PO bid
- Atenolol 25-100 mg PO qd
- Digoxin 0.25-0.5 mg PO qd.

Radiofrequency Ablation

It offers definitive cure for different type of SVTs:

- AVNRT/AVRT



- Accessory pathway mediated tachycardias
- Focal atrial tachycardia
- Atrial flutter.

Complications of radiofrequency ablation (Less than 1%)

- Groin haematomas
- Bleeding
- Cardiac perforation
- Cardiac tamponade
- Complete heart block
- Stroke

With the advent of successful radiofrequency ablation, antiarrhythmic agents are rarely indicated for the management of SVT.

Specific Management

Sinus tachycardia: The cause has to be identified and treated accordingly.

Atrial tachycardia: It is rare and usually due to digoxin toxicity. Stop digoxin and maintain potassium level at 4-5 mmol/L. Digoxin-specific Fab antibody fragments should be used.

Multifocal tachycardia: It is most commonly seen in COPD. After correcting hypoxia and hypercapnia, if the heart rate remains > 110 b/minute verapamil should be used.

Junctional tachycardia: If vagal manoeuvres fail adenosine can be used. If it recurs beta-blocker and amiodarone should be used. Radio-frequency ablation is most ideal in the management.

Atrial fibrillation: Management protocol consists drugs to reduce rate, rhythm correction and to prevent thrombo-embolism by using anticoagulants.

Acute AF (< 72 hours) – Treat the associated acute illness such as MI/Pneumonia.

- Control ventricular rate with digoxin
- For persistent fast ventricular rate add either verapamil or beta-blocker.
- Drug—Cardioversion can be tried with either amiodarone or flecainide.

Amiodarone: 5 mg/kg over one hour—then 100 mg over two hours with central line—maximum of 1-2 grams in 24 hours or PO 200 mg tid in the first week—200 mg bid second week—100-200 mg od for maintenance.

Flecainide: 2 mg/kg IV over 30 minutes (maximum of 150 mg) or

PO 50-200 mg q 12th hourly.

Ibutilide: 1mg IV over 10 minutes—Repeat 1 mg if required.

Dofetilide: PO 125-500 mcg q 12 h

- DC—Cardioversion is indicated electively following the first attack of AF with an identifiable cause and as an emergency if the patient is compromised (200 J – 360 J – 360 J).

Anticoagulation with warfarin is essential for 3 weeks before and 4 weeks after cardioversion to prevent thrombo-embolic episodes.

Paroxysmal AF: Sotalol 80-320 mg q 12 h PO or amiodarone

Chronic AF: Digoxin is the ideal drug to control the ventricular rate. Amiodarone is the most effective antiarrhythmic agent for the maintenance of sinus rhythm.

Anticoagulation: Anticoagulation is not required if AF is of recent onset with structurally normal heart on echo, but aspirin may be given. In all other cases of AF, anticoagulation with warfarin should be given. It is further categorised as AF with high and moderate risk factors.

AF with high risk factors:

- Age greater than 75 years
- Previous stroke or TIA
- Systemic embolus
- Valvular heart disease
- Poor LV systolic function.

AF with moderate risk factors:

- Age between 65-75 years
- Diabetes mellitus
- Hypertension
- CAD with normal LV function.

Use warfarin to keep the INR 2-3 in patients with one high risk factor or more than 2 moderate risk factors. Warfarin is not indicated for patients without risk factors and in them, use aspirin 325 mg od.

Atrial flutter: Management is similar to AF including anticoagulation. If drugs fail, consider 'cavotricuspid isthmus' ablation. This flutter isthmus is low in the right atrium.

Atrial Extrasystoles (Fig. 3.75)

This is characterised by the presence of a bizarre P-wave, which may be pointed, notched, bi-phasic, or inverted

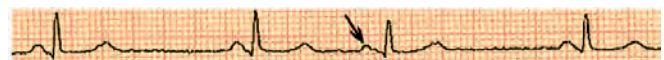

Fig. 3.75: Atrial extrasystole

and which occurs earlier than the next anticipated sinus P-wave. The width of the QRS complex is normal. The compensatory pause is relative.

AV Node

AV Nodal Extrasystole (Fig. 3.76)

This is similar in appearance to atrial extrasystole on the ECG. P-waves may either precede, merge with, or follow the QRS complex depending on whether the ectopics arise from the upper, mid or lower part of the AV node respectively.



Fig. 3.76: AV nodal extrasystole

Paroxysmal AV Nodal Tachycardia

This may be defined as a succession of three or more AV nodal extrasystoles and has similar characteristics as that of atrial tachycardia.

Ventricular

Ventricular Extrasystole

This is characterised by the appearance of a pre-mature and bizarre (widened and slurred or notched) QRS complex, with associated secondary ST-T changes (when the QRS complex is dominantly upright, the ST segment is depressed and T-wave is inverted. When the QRS complex is dominantly downwards, the ST segment is elevated and T-wave is upright). The ventricular extrasystole is followed by an absolute compensatory pause.

Ventricular ectopics may be benign, due to excessive ingestion of coffee, tea, alcohol, cold water, smoking, or emotional stress.

T-wave inversion if present in normal complex immediately following the ventricular ectopic indicates the presence of underlying ischaemia (*Poor man's stress test*).

Ventricular ectopics (Fig. 3.77) with a predominant negative QRS deflection in the right precordial leads (V_1, V_2) indicate that ectopics originate from RV, and are usually benign. Similarly the presence of ectopics with predominant negative QRS deflection, in the left precordial leads (V_4, V_5, V_6) indicate that ectopics originate from LV and are usually pathological.

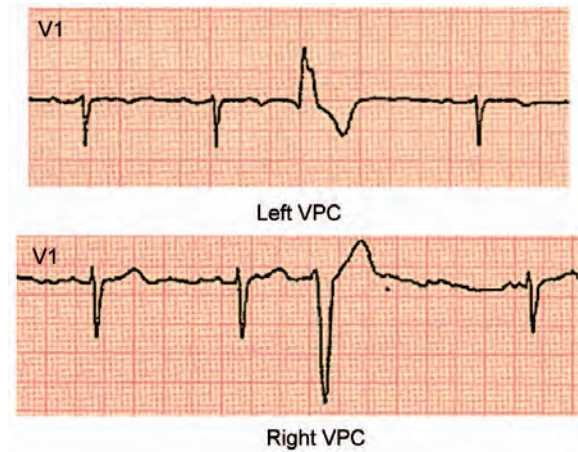

Fig. 3.77: Ventricular ectopics

Types of Ventricular Extrasystole

Extrasystolic ventricular bigeminy (Fig. 3.78): Alternate ventricular extrasystoles, i.e. extrasystoles which occur after every other sinus beat, are the most common cause of bigeminal rhythm and a frequent manifestation of digitalis intoxication.

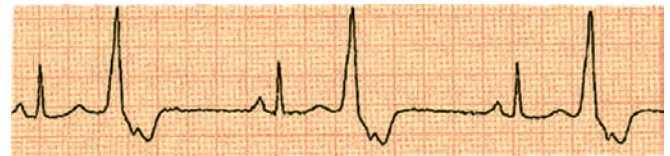

Fig. 3.78: Ventricular bigeminy

Multifocal or multiform ventricular extrasystoles: Extrasystoles that arise from different foci and consequently give rise to different QRS complexes are termed multifocal or multiform ventricular extrasystoles.

Extrasystoles in pairs (Fig. 3.79): When a ventricular ectopic focus discharges prematurely and twice in succession, the rhythm will manifest as a pair of extrasystoles, namely a sinus beat followed by two extrasystoles. (ventricular trigeminy).



Fig. 3.79: Extrasystoles in pairs



Extrasystolic paroxysmal ventricular tachycardia: Three or more successive ventricular extrasystoles constitute an extrasystolic ventricular tachycardia—a paroxysmal tachycardia.

Note: Ventricular extrasystoles are always significant when associated with myocardial disease.

Multifocal ventricular extrasystoles and ventricular extrasystoles in pairs are always abnormal and usually indicative of serious myocardial disease.

Unifocal ventricular extrasystoles are usually indicative of cardiac disease if (i) they occur in 'crops' or 'showers' (ii) they occur in bigeminal rhythm (iii) they occur in association with cardiac disease (iv) they occur in persons over 40 years of age, or (v) they are precipitated by exercise.

Frequent ventricular extrasystoles, especially those occurring in pairs, often herald ventricular tachycardia or ventricular fibrillation.

A ventricular extrasystole occurring prematurely so as to be superimposed on the T-wave of the preceding complex, may be prone to precipitate ventricular fibrillation.

Broad Complex Tachycardia

All possible attempts must be made to differentiate between ventricular tachycardia and SVT with aberrant conduction because of the clinical implications and management of these two arrhythmias are totally different. SVTs are amenable to adenosine, calcium channel blockers and radiofrequency ablation, whereas most VTs are malignant and require anti-arrhythmic agents or implantable defibrillators.

Characteristics suggestive of VT

- AV dissociation
- Fusion beats
- Capture beats
- LBBB morphology with right axis deviation
- QRS morphology suggestive of VT
 - LBBB: In lead V_1 - V_2 ~ R > 30 msec or R to S > 60 msec or notched S wave
 - In lead V_6 ~ QR or QS
 - RBBB: In lead V_1 - V_2 ~ Monophasic R or QR or RS
 - In lead V_6 ~ R/S < 1

Sustained Monomorphic VT

Three or more successive ventricular pre-mature complexes are termed ventricular tachycardia. It is called sustained when it lasts longer than 30 seconds at a rate of 100 to 250 beats/minute with only one type QRS morphology throughout the arrhythmia.

Polymorphic VT

It is characterised by changing QRS morphology from beat to beat and is frequently due to coronary artery disease. Torsade de pointes (TdP) is a polymorphic VT that is preceded by a prolonged QT interval in sinus rhythm (Fig. 3.80).

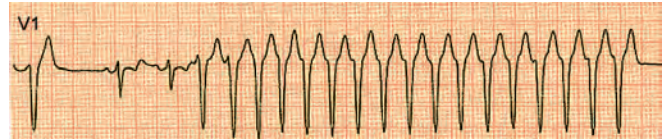

Fig. 3.80: Ventricular tachycardia

Ventricular Flutter (Fig. 3.81)

(Heart rate—150–300). This is characterised in the ECG by a very rapid and regular ectopic ventricular discharge. The QRS and T deflections are very wide and bizarre, resulting in a sine-like waveform.

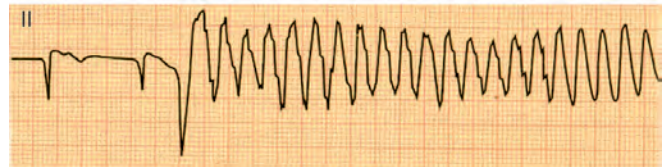

Fig. 3.81: Ventricular flutter

Note: Ventricular flutter differs from ventricular fibrillation in the uniformity, constancy, regularity and relatively large amplitude of the deflections. The deflections of ventricular fibrillation are small and completely chaotic and irregular.

Torsades de pointes (Fig. 3.82): Ventricular flutter may present with multiform QRS complexes, a manifestation which has been termed 'torsades de pointes'.

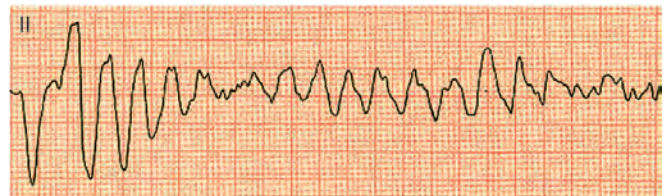

Fig. 3.82: Torsades de pointes

In this presentation, the QRS complexes tend to be bizarre and multiform, and have sharply pointed apices or nadirs. This form of ventricular flutter is likely to complicate advanced and third degree AV block, and is frequently associated with syncopal attacks. The syncopal attacks may result in marked prolongation of the QT_c interval and there may be 'giant T-wave inversion'.

This may be an expression of
Severe coronary artery disease
Hypokalaemia
Hypomagnesaemia
Quinidine therapy.

Ventricular Fibrillation (Fig. 3.83)

This is characterised in the ECG by the presence of completely irregular, chaotic, and deformed deflections of varying height, width and shape.

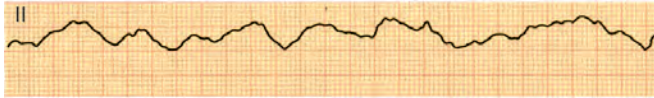

Fig. 3.83: Ventricular fibrillation



Management of Broad Complex Tachycardia

Haemodynamically stable VT:

- Correct hypokalaemia and hypomagnesaemia
- Amiodarone 150 mg IV over 20 minutes and then 300 mg over 1 hour or
- Lignocaine 50 mg IV over 2 minutes and repeated every 5 minutes to a maximum of 200 mg.

If the above drugs fail or the patient haemodynamically unstable:

- DC cardioversion – 200 J – 200 J – 360 J

Resistant VT/VF:

- Amiodarone 300 mg IV followed by an infusion 1 mg/minute for 6 hours and then 0.5 mg/minute for another 6 hours or
- Lidocaine 100 mg IV–repeat once more –followed by infusion 2-4 mg/minute or Procainamide 30 mg/minute IV–maximum dose 15 mg/kg or
- Bretylium 5 mg/kg and repeat boluses as needed to a maximum of 35 mg/kg or sotalol–use with caution in the presence of congestive heart failure.

TdP associated with long QT syndrome:

- Immediate DC cardioversion
- Magnesium sulfate IV bolus 1-2 grams (maximum 4-6 grams).

Prevention of Recurrent VT:

- Radiofrequency catheter ablation of VT for haemodynamically stable forms of VT without structural heart disease.
- Surgical isolation of arrhythmogenic area
- Implantation of tiny automatic defibrillators

Indications for implantable cardioverter-defibrillators (ICDs):

- Spontaneous VT with structural heart disease
- Irreversible causes for VT/VF
- Recurrent VT/VF
- Failure of anti-arrhythmic agents to control VT
- Patients with high risk for sudden cardiac death (SCD).

II. Bradyarrhythmias

Sick Sinus Syndrome

(Tachy-Brady Syndrome)

This is due to sinus node dysfunction and ECG shows sinus bradycardia, sometimes associated with AV nodal block or SVT alternating with bradycardia or asystole.

Heart Block

First degree heart block (Fig. 3.84) is characterised by a constantly prolonged PR interval (> 0.20 sec.)



Fig. 3.84: First degree AV block

Second Degree Heart block

- Mobitz type I* (Fig. 3.85): The PR interval increases with each cycle until there is a P-wave which is not followed by a QRS complex (*Wenckebach's phenomenon*)



Fig. 3.85: Second degree heart block (Mobitz type 1- Wenckebach type)

- Mobitz type II* (Fig. 3.86): The P-R interval is constant. Some P-waves are not followed by a QRS complex and the degree of block can be quantified as 2:1, 3:1, etc.

Complete or third degree heart block (Fig. 3.87) is characterised by the P-waves and the QRS complexes occurring completely independent of each other.

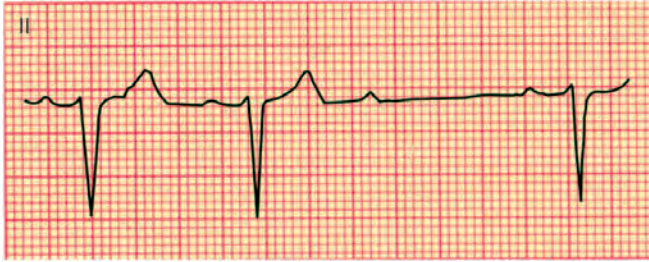

Fig. 3.86: Second degree heart block (Mobitz type 2)

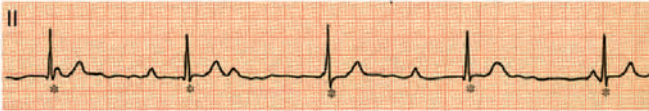

Fig. 3.87: Complete heart block

Administration of 1–2 mg of atropine IV does not increase the heart rate in sick sinus syndrome and complete heart block, whereas the heart rate increases in sinus bradycardia and first or second degree heart blocks.

Indications for Permanent Pacemakers

- Symptomatic sinus bradycardia or AV block
- Advanced AV block with:
 - i. Asystole > 3 seconds
 - ii. Escape rates < 40 beats/minute
 - iii. Catheter ablation of AV node
 - iv. Neuromuscular disorders
 - v. Post-operative AV block (recovery remote)
- Extreme degree of sinus bradycardia due to essential drug therapy
- Intermittent complete heart block
- Intermittent type II second-degree block
- Alternating bundle branch block
- Carotid sinus massage induced syncope causing asystole > 3 seconds.

Exercise (Stress) ECG

By performing an ECG during progressively increasing exercise (on a treadmill), it is possible to detect stress induced arrhythmia or evidence of ischaemia.

1. Horizontal or downsloping ST segment depression of >1 mm suggests ischaemia.
2. Failure to achieve an increase in BP or occurrence of a fall in BP during exertion is an evidence for ventricular decompensation and is indicative of extensive ischaemia.
3. Inability to achieve the predicted heart rate renders the test inconclusive (predicted heart rate is 220 – age of the patient).

Following MI, it is used in assessing the risk.

Contraindicated in

1. Unstable angina
2. Decompensated heart failure
3. Severe hypertension or outflow tract obstruction, e.g. AS.

Holter Monitoring or Ambulatory ECG

For detecting transient episodes of arrhythmia or ischaemia which seldom occur fortuitously during the short time taken for routine 12 lead ECG monitoring.

Stress ECHO

A stress ECHO can be done following administration of adenosine, dobutamine or dipyridamole to detect evidence of ischaemia.

Congenital Heart Diseases

Classification of Congenital Heart Diseases

Gross Anomalies

1. Ectopia cordis
2. Cardiac malpositions
3. Congenital complete heart block.

Lesions Without Shunts

Left Heart Malformations

- i. Congenital obstruction to left sided inflow
 - a. Pulmonary vein stenosis
 - b. Cor triatriatum
 - c. Mitral stenosis.
- ii. Mitral regurgitation
 - a. Mitral valve prolapse
 - b. Double orifice mitral valve
 - c. Congenital perforation
 - d. Cleft posterior leaflet
 - e. Parachute mitral valve
 - f. Chordae anomalies.
- iii. Aortic stenosis
 - a. Supravalvular
 - b. Valvular
 - c. Subvalvular.
- iv. Aortic valve regurgitation.
- v. Coarctation of aorta.

Right Heart Malformations

- i. Acyanotic Ebstein's anomaly



- ii. Pulmonic stenosis
 - a. Supravalvular
 - b. Valvular
 - c. Infundibular
 - d. Subinfundibular.
- iii. Congenital pulmonary valve regurgitation
- iv. Idiopathic dilatation of the pulmonary trunk
- v. Pulmonary artery branch stenosis.

Shunt Lesions—Left to Right (Acyanotic)

Atrial Level Shunt

- i. Atrial septal defect (ASD)
 - a. Ostium primum
 - b. Ostium secundum
 - c. Sinus venosus.
- ii. ASD with acquired mitral stenosis (Lutembacher's syndrome).
- iii. Partial anomalous pulmonary venous connection.

Ventricular Level Shunt

- i. Ventricular septal defect (VSD)
 - a. Perimembranous or paramembranous defect
 - b. Muscular defect
- ii. VSD with aortic regurgitation
- iii. VSD with left ventricular to right atrial shunt (Gerbode defect).

Aortic Root to Right Heart Shunt

- i. Ruptured sinus of Valsalva aneurysm
- ii. Coronary arteriovenous fistula
- iii. Anomalous origin of left coronary artery from the pulmonary artery (ALCAPA).

Aorto-pulmonary Level Shunt

- i. Aorto-pulmonary window
- ii. Patent ductus arteriosus (PDA).

Multiple Level Shunts

- i. VSD with ASD
- ii. VSD with PDA.

Shunt Lesions—Right to Left (Cyanotic)

With Increased Pulmonary Blood Flow

1. Complete transposition of the great arteries
2. Double outlet right ventricle
3. Truncus arteriosus
4. Total anomalous pulmonary venous connection.

With Normal or Decreased Pulmonary Blood Flow

1. Tetralogy of Fallot
2. Tricuspid atresia
3. Ebstein's anomaly with right to left atrial shunt
4. Pulmonary atresia with intact ventricular septum
5. Pulmonary arteriovenous fistula.

Cyanotic congenital heart disease with prominent LV apex—tricuspid atresia.

Incidence of Congenital Heart Diseases

Congenital heart disease	Percentage
1. Ventricular septal defect	30%
2. Patent ductus arteriosus	10%
3. Aortic stenosis	10%
4. Pulmonary stenosis	10%
5. Tetralogy of Fallot	10%
6. Atrial septal defect	7%
7. Mitral valve prolapse	7%
8. Coarctation of aorta	5%
9. Transposition of the great arteries	5%
10. Truncus arteriosus	1%
11. Total anomalous pulmonary venous connection	1%
12. Tricuspid atresia	1%
13. Miscellaneous	3%

The incidence of coarctation of aorta, transposition of the great arteries, and aortic stenosis is greater in males.

The incidence of patent ductus arteriosus and atrial septal defect is greater in females.

The incidence of other congenital heart diseases is almost equal in both males and females. Figure 3.88 shows various external markers of congenital heart diseases.

Cardiac Malposition (Figs 3.89 to 3.91)

An abnormal anatomic position of the entire heart or its chambers constitutes a cardiac malposition.

Normally, cardiac apex is to the left side of chest—*levocardia*.

When cardiac apex is to the right side of chest—*dextrocardia*.

When cardiac apex is situated over the centre of chest—*mesocardia*.

In describing a cardiac abnormality, three segments must be individually considered.

1. The position of the atria
2. The position of the ventricles and their connections to the atria



Fig. 3.88: External markers of congenital heart disease

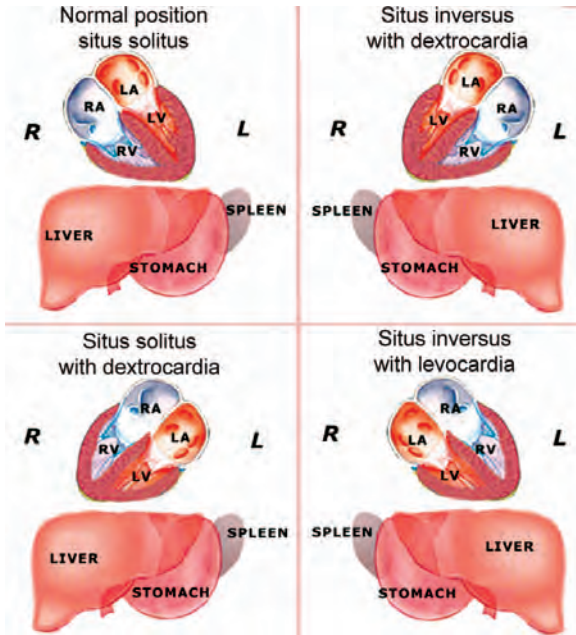

Fig. 3.89: Cardiac malpositions

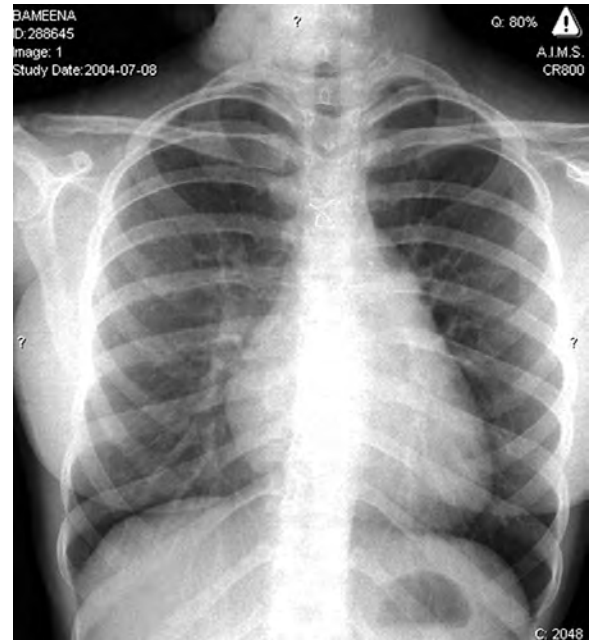
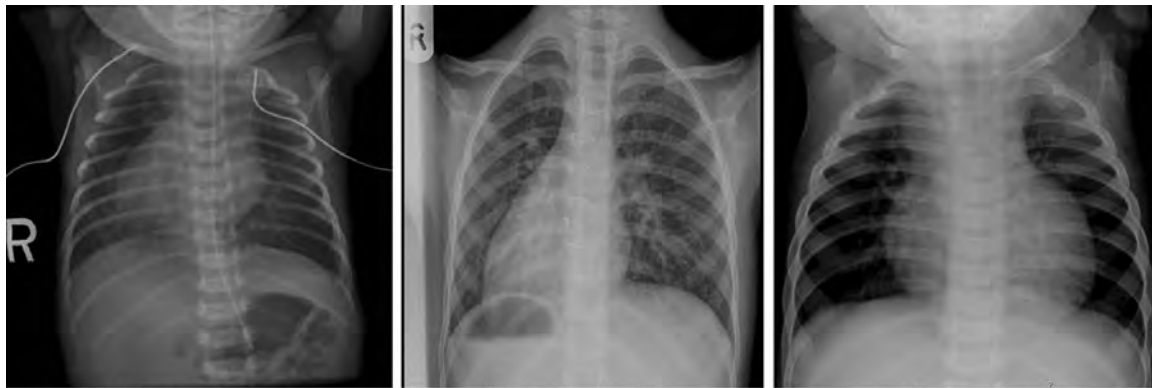

Fig. 3.90: Situs solitus



Dextrocardia

Situs inversus totalis

Situs ambiguus

Fig. 3.91: Cardiac malpositions

3. The position of the great vessels and their connections to the ventricles.

(1) In general, the position of the atria can be identified by the body situs (configuration of the visceral organs).

The liver and right atrium are located on the same side of the body.

The left atrium is on the same side as that of stomach and spleen.

The normal arrangement of abdominal viscera and atria is termed *situs solitus*.

When the abdominal viscera (along with the atria) is completely reversed, it is termed *situs inversus*.

Situs ambiguus is associated with asplenia or polysplenia, when the cardiac position cannot be determined.

(2) After determination of the viscerocardiac situs, one must define the position of the ventricles and their connections to the atria. The ventricles are morphologically different and can usually be distinguished on the basis of angiography or echocardiography. The atrioventricular valves always remain with their respective ventricles.

In normal development, the primitive, straight cardiac tube bends to the right, forming the so-called



d-loop (d for dextro or right). This places the morphologic right ventricle to the right of the morphologic left ventricle. Conversely, if the cardiac tube bends to the left, an l-loop (l for levo or left) is formed and the morphologic right ventricle lies to the left of the left ventricle.

Using this classification, a d-loop is normal in situs solitus (the liver and the right atrium, connected to the right ventricle, are situated on the patient's right side. The right ventricle lies to the right of left ventricle).

An l-loop is normal in situs inversus (the liver and the right atrium, connected to the right ventricle are situated on the patient's left side. The right ventricle lies to the left of left ventricle).

- (3) The anatomy of the great arteries is defined in terms of
- Their positional relationships
 - Their ventricular attachments.

The positional relationships of the great vessels are described as d (dextro) when the ascending aorta lies to the right of the pulmonary artery. It is described as l (levo) when the aorta lies to the left of the pulmonary artery.

Examples

- Normal heart would be described as solitus/d-loop/d-normal
- Situs inversus and dextrocardia is described as inversus/l-loop/l-normal.

Dextrocardia

Dextrocardia with Situs Inversus (Situs Inversus Totalis)

Dextrocardia, with situs inversus is the relatively common condition that is usually an incidental finding on chest X-ray or physical examination and is generally benign. About 90% of patients with this condition have hearts that are otherwise normal.

The ECG shows negative P-wave in standard lead I.

If the left and right arm leads are reversed and the precordial leads are positioned across the right side of the chest, the ECG appears normal.

Isolated Dextrocardia

Patients with isolated dextrocardia without situs inversus almost invariably have additional cardiac malformations, the most common being

- Corrected transposition of the great vessels
- Pulmonic stenosis
- Ventricular septal defect
- Atrial septal defect.

Cardiac Abnormalities with Various Genetic Disorders

Genetic diseases of the heart may be classified into one of three categories

- Chromosomal disorders
- Single-gene disorders (autosomal dominant or recessive; or X-linked)
- Multifactorial disorders.

Patients with chromosomal or single-gene defects comprise 5 to 10% of subjects with congenital heart disease and generally have abnormalities in multiple organ systems. Patients with multifactorial inheritance pattern have discrete cardiac abnormality (VSD, ASD, PDA) without abnormalities in other organs.

Chromosomal Disorders

- Down syndrome (Trisomy-21)
 - Endocardial cushion defect
 - VSD
 - Tetralogy of Fallot
 - ASD (ostium primum)
 - PDA
 - Transposition of great vessels
 - Coarctation of aorta.
- Turner's syndrome (45 XO)
 - Coarctation of aorta
 - Bicuspid aortic valve
 - Aortic stenosis.

Single-gene Disorders

- Noonan's syndrome (autosomal dominant disorder)
 - Dysplasia of pulmonary valve, with resultant stenosis
 - ASD
 - HOCM.
- Williams syndrome (autosomal dominant disorder)
 - Supravalvular aortic stenosis
 - Peripheral pulmonary artery stenosis.
- Leopard syndrome (autosomal dominant disorder)
 - Complete heart block
 - Pulmonic valve stenosis.
- Holt-Oram syndrome (autosomal dominant disorder)
 - ASD (ostium secundum)
 - VSD.
- Supravalvular aortic stenosis (autosomal dominant disorder)
- Kartagener's syndrome (autosomal recessive disorder)

- a. Dextrocardia with situs inversus
- b. Transposition of great vessels.
- vii. Hereditary disorders of connective tissue (Marfan's syndrome, Ehlers-Danlos, homocystinuria)
 - a. Mitral or tricuspid valve prolapse
 - b. Premature coronary artery disease
 - c. Aortic regurgitation
 - d. Mitral regurgitation.
- viii. Cardiomyopathy
 - a. HOCM
 - b. Familial dilated cardiomyopathy.

Atrial Septal Defect (ASD)

It is the most common congenital heart disease presenting with symptoms in adults. There are four types of ASD; of which first three are most common (Fig. 3.92):

ASD is more common in females.

1. Ostium secundum (90%)
2. Ostium primum (5%)
3. Sinus venosus (5%).
4. Coronary sinus type –very rare

Ostium primum type of ASD is commonly associated with either Down's syndrome or with endocardial cushion defects (MR, TR).

Ostium secundum type of ASD can be sporadic or transmitted as autosomal dominant condition.

PFO (Persistent foramen ovale) – there is only anatomical patency.

In ostium secundum ASD there is both anatomical and functional patency.

Syndromes with ASD

1. Holt-Oram syndrome (Ostium secundum ASD)
Triphalangeal (fingerised) thumb, sometimes abrachia or phocomelia, autosomal dominant inheritance.

2. Trisomy 13 (Patau syndrome)
Polydactyly, flexion deformity of fingers, simian crease, microcephaly, holoprosencephaly, cleft lip and palate and low set malformed ears (ASD, VSD, PDA)
3. Trisomy 18 (Edward syndrome)
Prominent occiput, low set malformed ears and micrognathia together with clenched fists and rocker bottom feet (ASD, VSD, PDA)
4. Others: Ellis van Creveld (polydactyly, nail dysplasia, chondrodystrophic dwarfism), TAR (thrombocytopenia and absent radius), trisomy 21 and rubella.

ASD can be associated with

- a. MVP
- b. Acquired MS (Lutembacher's syndrome).

Sinus venosus type of ASD occurs high in the septum near the SVC entrance. It is sometimes associated with partial anomalous pulmonary venous connection.

- AF is common in ASD.
- Infective endocarditis is uncommon in ASD, except in ostium primum type, due to associated MR or TR.



Clinical Features

- a. One-third of patients with ASD have a systolic thrill. If thrill is prominent, associated PS should be thought of.
- b. Wide, fixed split of S_2 is the characteristic auscultatory finding of ASD
- c. S_2 split is narrowed with development of PHT
- d. Split is variable with development of AF
- e. Flow ESM across pulmonary valve
- f. Flow MDM across tricuspid valve.



Differential Diagnosis

1. Partial anomalous pulmonary venous connection can simulate ASD (Acyanotic).

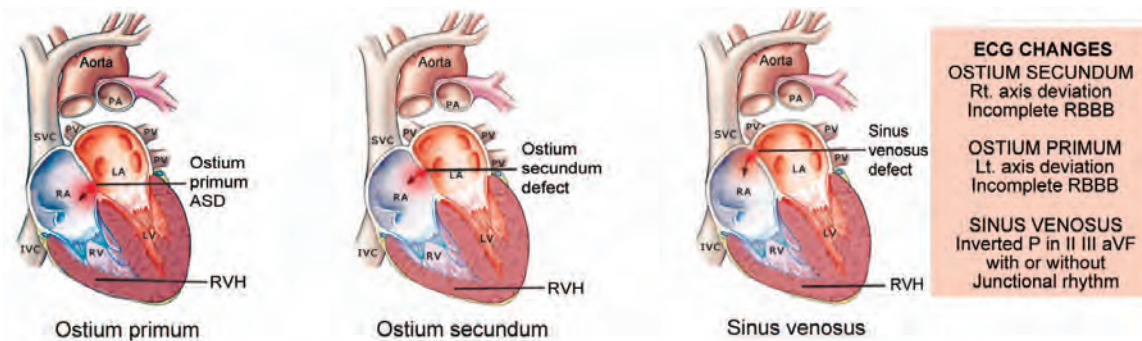

Fig. 3.92: Types of atrial septal defect



2. Total anomalous pulmonary venous connection with a large interatrial communication without pulmonary hypertension or pulmonary venous obstruction can also simulate ASD (Cyanotic).
3. MS with pulmonary hypertension.

ECG

- a. *Ostium secundum*: RAD with RV dominance and incomplete RBBB
- b. *Ostium primum*: LAD with incomplete RBBB
- c. *Sinus venosus*: Inverted P-wave in inferior leads. Junctional rhythm may be present.

Rarely ostium primum defects may be associated with complete heart block.

Chest X-ray

Dilated right atrium, right ventricle and pulmonary arteries, with a less prominent aortic knuckle gives a characteristic 'Jug handle appearance' (Fig. 3.93). Dilatation of SVC is in favour of sinus venosus type of ASD.

The lung fields are plethoric.



Fig. 3.93: Jug handle appearance

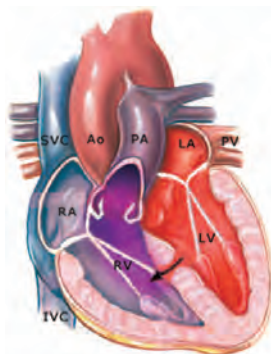

Ventricular septal defect

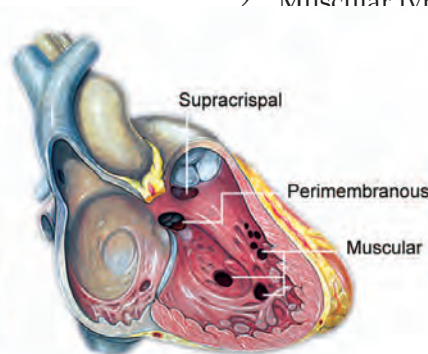

Types of VSD

ECG CHANGES
KATZ - WATCHEL PHENOMENON
Large equiphasic QRS
in V2 V3 V4

Fig. 3.95: Ventricular septal defect

Rx Treatment

Surgical closure (ideal age 3–6 years). Indication for surgery—significant shunt with pulmonary to systemic flow > 1.5 : 1.

A new non-invasive surgical procedure is closure of the defect using an umbrella (Fig. 3.94). However, ASDs can close spontaneously upto 2 years of age.

Prosthetic closure of ASD using pericardial graft can be done.

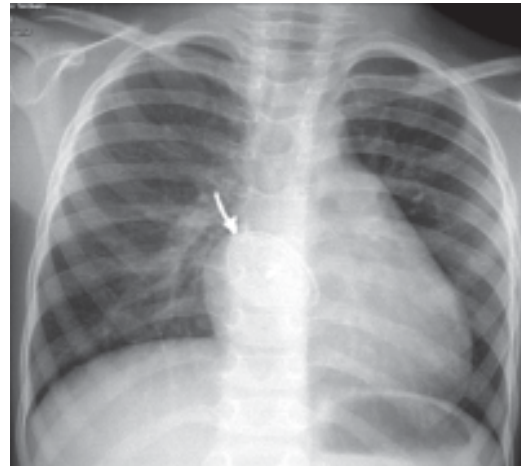

Fig. 3.94: Device closure of ASD

Ventricular Septal Defect (VSD)

This is the most common congenital heart disease.

Classification (Fig. 3.95)

1. Perimembranous or paramembranous type (most common 80%).

It has variable extension into outlet, inlet or trabecular septum. It is also called infracristal, sub-aortic or conoventricular type.

2. Muscular type



It can be of 3 types

- Inlet (8%)
- Trabecular (central, apical or marginal) (5–20%) (or swiss cheese type –multiple sieve like)
- Outlet (5–7%). It is also called as supracristal, subpulmonic, conoseptal, subarterial or infundibular.

Syndromes with VSD

- Trisomy's 8,13,18 and 21.
- Cri du chat syndrome (cat cry, microcephaly, mental retardation, anti-mongoloid slant).
- Cornelia de Lange syndrome (micromelia, mental and growth retardation).
- Klippel-Feil syndrome.
- Velocardio facial syndrome (cleft palate, prominent nose, slender hands, learning disability).
- Foetal alcohol syndrome (microcephaly, growth and mental retardation, thin upper lip, short palpebral fissure).
- Apert syndrome (craniosynostosis, mid-facial hypoplasia, syndactyly).
- Conradi-Hunermann syndrome (asymmetrical limb shortness, large skin pores, early punctate mineralisation).
- VATER association (vertebral anomaly, anal atresia, tracheoesophageal fistula, renal and radial anomalies).

Ventricular septal defects may vary in size, shape and number.

Spontaneous closure of the defect may occur in 50% of those having a defect less than 0.5 cm in diameter (in muscular septal defect only) up to 6 years of age.

Mechanism of Closure of Defect

- Septal muscle grows around defect.
- Prolapsed aortic or tricuspid valve gets adherent to defect along with over growth of fibrous tissue.
- Infective endocarditis occurrence or development of ventricular septal aneurysm may close the defect.

Anatomical location of subaortic VSD predisposes for aortic valve prolapse and development of AR.

VSD may produce symptoms much earlier in life.



Clinical Features

- Grade IV pansystolic murmur over 3rd or 4th intercostal space in the left parasternal region with signs of bi-ventricular enlargement.
- A mid-diastolic flow murmur may be heard across the mitral valve.
- Occurrence of infective endocarditis is very common.

Maladie-de-Roger Syndrome

It is a small sized muscular VSD with a prominent thrill and a loud pansystolic murmur, without any haemodynamic changes. ECG is normal. Spontaneous closure of defect may occur.

ECG

May show evidence of bi-ventricular enlargement with or without RBBB and occasionally with complete heart block.

Chest X-ray/USG

Left ventricular enlargement with pulmonary plethora (Fig. 3.96). VSD with patent foramen ovale (Fig. 3.97).

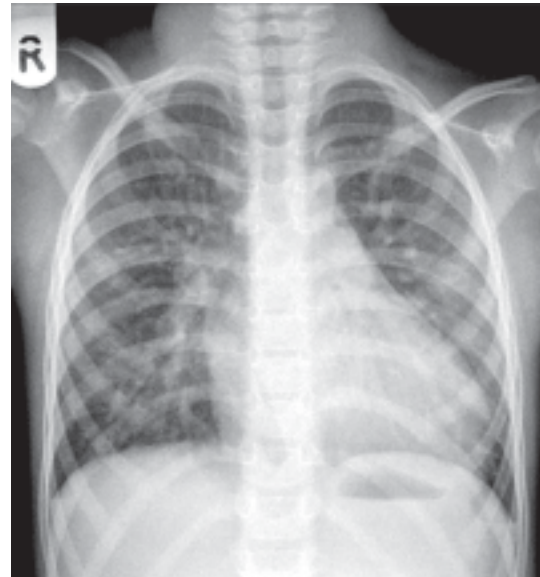

Fig. 3.96: X-ray showing pulmonary plethora

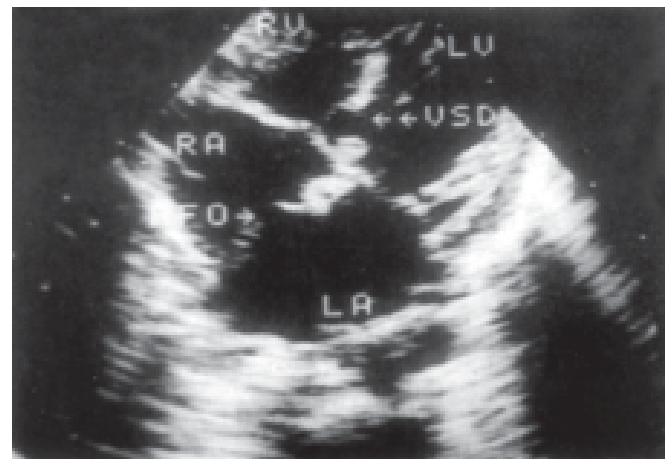

Fig. 3.97: Ventricular septal defect with patent foramen ovale



Rx Treatment

- Surgical closure is the treatment of choice.
- Ideal age for surgery < 2 years of age.
- Indication for surgery is when pulmonary to systemic blood flow is > 1.5 : 1.

Patent Ductus Arteriosus (PDA) (Fig. 3.98)

The ductus arteriosus connects the descending aorta (distal to left sub-clavian artery origin) and the left pulmonary artery (just after the bifurcation of the main pulmonary artery).

Functional closure (physiological) occurs within 24-48 hours of birth, and the anatomical closure is complete in 2-3 weeks after birth.

Physiological closure, due to muscular contraction, is influenced by abrupt rise in P_aO_2 and reduction in the local Prostaglandin-E synthesis.

Infants born at high altitudes and premature infants have a higher incidence of PDA. Its incidence is also high when the mother is affected by rubella in the first trimester of pregnancy.

Compared to ASD and VSD, about 85–90% of PDAs occur as isolated defects without associated anomalies.

Syndromes with PDA

1. Maternal rubella syndrome (cataract, deafness, microcephaly)

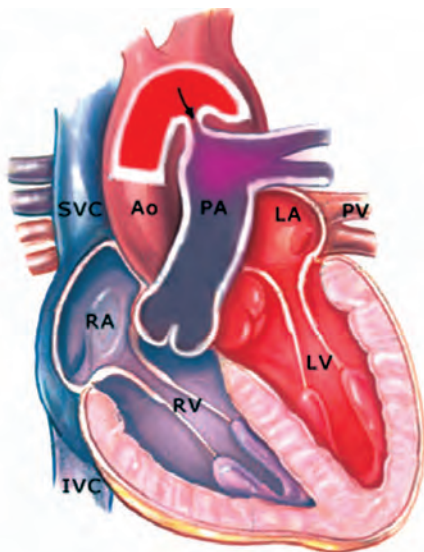

Fig. 3.98: Patent ductus arteriosus

2. Trisomy 18.
3. Foetal hydantoin syndrome (Hypertelorism, growth and mental retardation, short phalanges, bowed upper lip).
4. Incontinentia pigmenti (patchy alopecia, irregular pigmented skin lesions, hypodontia).
5. Crouzon syndrome (ptosis with shallow orbit, craniosynostosis, maxillary hypoplasia).
6. Rubinstein-Taybi syndrome (broad thumbs and toes, maxillary hypoplasia, slanted palpebral fissure).
7. Conradi-Hunermann syndrome.



Clinical Features

Grade IV continuous murmur heard best over the left second intercostal space at mid-clavicular line.

Differential Diagnosis of Continuous Murmurs

Location	Underlying Disease Entity
Left upper sternal border and below left clavicle	PDA
Second to fourth intercostal spaces	Aortopulmonary septal defect
Along the lower left sternal border	Rupture of sinus of Valsalva aneurysm
Over lower or mid-sternal border or entire precordium	Coronary arteriovenous fistulae
May be audible anywhere over the chest	Pulmonary arteriovenous fistulae

ECG

Left atrial enlargement is commonly seen.

Left ventricular enlargement may be seen (volume overload). Right ventricular enlargement may be seen (pressure overload).

Chest X-ray

The lung fields are plethoric (Fig. 3.100).

The angle between the main pulmonary artery and aortic knuckle can be obliterated by presence of a patent ductus.

Calcification at the site of ductus indicates a fibrosed or a calcified ductus.

PDA can close spontaneously after early infancy.

Ductal endarteritis is common either near the ductal orifice in the pulmonary artery or in the pulmonary end of the ductus.

Aneurysms or rupture (secondary to development of aneurysm or calcification) of the PDA can occur.

Congestive cardiac failure is the commonest cause of death.

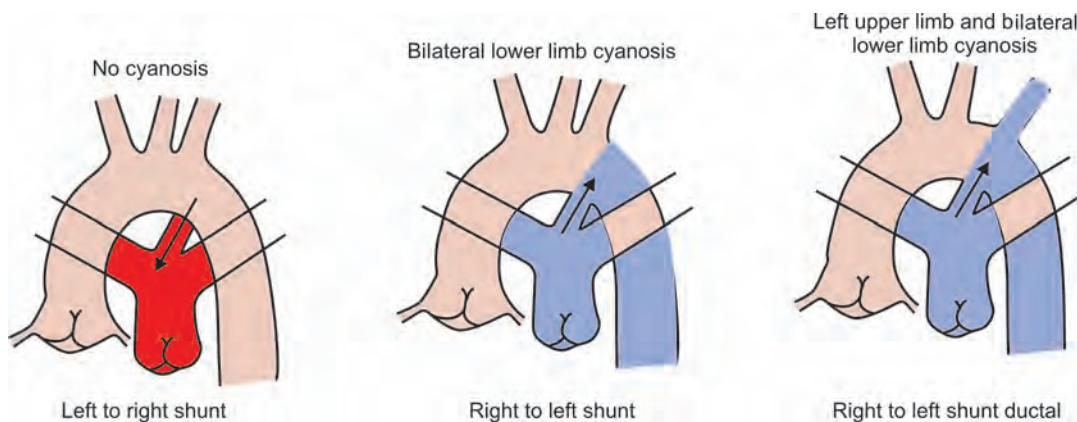

Fig. 3.99: Patent ductus arteriosus

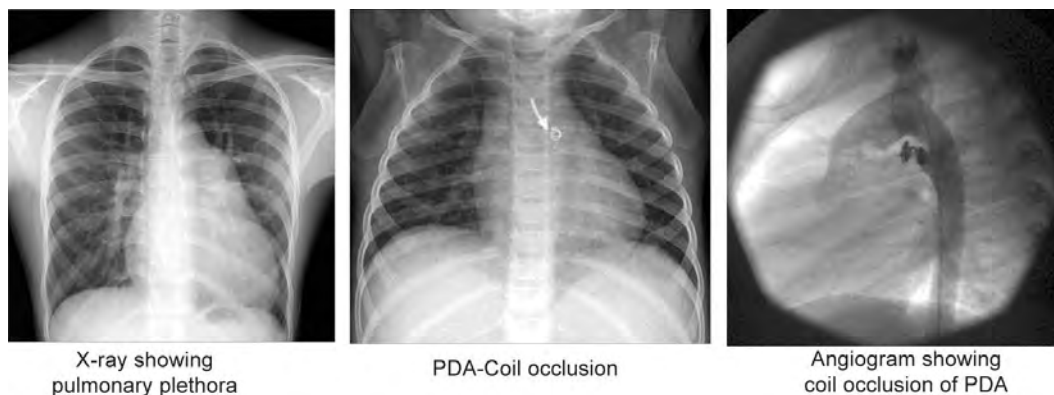

Fig. 3.100: Patent ductus arteriosus

Treatment

Medical: Administration of indomethacin within the first two to seven days of life.

Note: Indomethacin favours ductal closure by reducing prostaglandin levels especially PG-E.

Surgical: Ligation and excision of patent ductus. Ideal age for surgery is below two years.

Transcatheter closure of patent ductus using a variety of approaches using coils, buttons, plugs and umbrellas can be done (Fig. 3.101).

Conditions where PDA is essential for survival

1. Pulmonary atresia
2. Hypoplastic left heart syndrome
3. Preductal coarctation of aorta
4. Complete TGV without septal defects.



Fig. 3.101: VSD with Eisenmenger's syndrome



Eisenmenger Syndrome

It is the condition in which left to right shunt gets reversed (right to left) with the development of severe pulmonary hypertension, resulting in central cyanosis (Fig. 3.99), clubbing, and secondary polycythaemia (Fig. 3.101).

Its incidence is equal in both males and females.

Since this syndrome is uncommon below two years of age, surgical closure of left to right shunt lesions is advocated below two years of age.

Haemoptysis is uncommon, but when it occurs, prognosis is bad, as it is caused by rupture of thin-walled, fragile pulmonary arteries or their small aneurysms.

Conditions that cause systemic vasodilatation (exercise, fever, hot bath, hot weather) may exaggerate the shunt from right to left resulting in systemic desaturation and poor tolerance.

Clinical Features

- Generalised cyanosis occurs in presence of VSD and ASD.
- Differential cyanosis involving the lower limbs occurs in the presence of PDA (Fig. 3.99).
- P_2 is loud and palpable.
- There is a prominent parasternal heave.

Eisenmenger syndrome occurs earlier in life in VSD, a little later in PDA, and very late in adult life in ASD.

In ASD with reversal	Narrowly fixed split of S_2
In VSD with reversal (Eisenmenger complex)	Single S_2 and decreased intensity of murmur
In PDA with reversal	Closely split S_2 which varies normally with respiration.

Surgery is not contraindicated in the early phase of Eisenmenger's syndrome, developing as the result of volume overload without evidence of increased pulmonary vascular resistance (normal pulmonary wedge pressure).

Death is caused by

1. CCF
2. Pulmonary infection
3. Pulmonary thrombosis (pulmonary infarction)
4. Brain abscess
5. Infective endocarditis
6. Severe haemoptysis
7. Ventricular arrhythmias.

Pregnancy must be avoided or terminated with development of Eisenmenger's syndrome.

The only curative treatment of Eisenmenger's syndrome is heart-lung transplantation.



Differential Diagnosis

1. Primary pulmonary hypertension
2. Recurrent pulmonary embolism
3. Idiopathic dilatation of pulmonary artery.

Tetralogy of Fallot (TOF) (Fig. 3.102)

It is the most common cyanotic congenital heart disease in patients who survive infancy.

It is composed of 4 distinct anatomic abnormalities

1. Large non-restrictive VSD
2. Right ventricular outflow tract obstruction* (infundibular pulmonary stenosis)
3. Overriding of the aorta
4. Right ventricular hypertrophy.

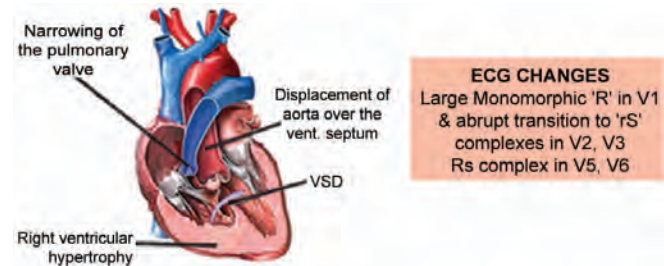

Fig. 3.102: Tetralogy of fallot

Embryology

TOF occurs as the result of anterocephalad malalignment of the infundibular septum, resulting in a ventricular septal defect, right ventricular outflow tract obstruction (subpulmonic obstruction) and overriding of the aorta.

Cyanotic Fallot

When the resistance to pulmonary outflow is greater than the systemic resistance, right to left shunting of blood across the VSD occurs, resulting in central cyanosis.

Acyanotic Fallot

When the resistance to the pulmonary outflow is lower than the systemic resistance, then a predominant left to right shunt occurs across the VSD and cyanosis is absent.

Initially, in TOF, cyanosis is episodic, occurring during feeding, crying, fever, exercise, etc, when

*Rarely valvular PS or a combination of infundibular and valvular PS may be present.

systemic vasodilatation occurs causing an increased right to left shunting across the VSD.

A baby born cyanotic is unlikely to have TOF.

Cyanosis becomes more prominent after about 5-6 months of life due to the following reasons:

a. HbF is the predominant Hb present in the first few years of life. It binds less avidly to O₂ and releases it easily at times of need. Hence, when an infant with TOF, in the first 5 to 6 months of life develops cyanotic spells, O₂ is easily released from HbF and hence cyanosis is minimal.

After 5-6 months of age, HbF is replaced by HbA₂. HbA₂ binds O₂ more avidly and releases it less readily at times of need and so the child becomes cyanotic.

b. With the growth of the child, the O₂ demand for growth increases and cyanosis becomes more prominent.

TOF may be associated with other cardiac anomalies like:

1. Patent foramen ovale
2. ASD
3. AR
4. Right sided aortic arch (It is the most common anomaly, seen in 25 to 30% of cases, its likelihood increasing with increasing severity of RVOT obstruction and particularly in pulmonary atresia)
5. PDA
6. Anomalous origin of the coronary arteries
7. Absence of left pulmonary artery.

Pentology of Fallot

Presence of ASD along with TOF is called pentology of Fallot.

Triology of Fallot

Right ventricular outflow tract obstruction with RV hypertrophy and right to left shunt across interatrial septum in the absence of VSD is called triology of fallot (PS, RVH, and ASD).

TOF Associated Syndromes

1. TAR (thrombocytopenia and absent radius)
2. Down syndrome (hypotonia, mental retardation, mongoloid facies, hyperextensible joints)
3. Di-George syndrome (Thymic hypoplasia, parathyroid hypoplasia, ear anomalies)
4. CHARGE association (coloboma, choanal atresia, mental and growth retardation, genital and ear anomalies)
5. Velocardiofacial.



Clinical Features

A silent precordium is often characteristic.

On auscultation, a loud, single S₂ (representing aortic valve closure) and an ESM is best heard over the 3rd and 4th left intercostal spaces.

The intensity and duration of the murmur is inversely proportional to the severity of RVOT obstruction.

Because of a large ventricular septal defect, VSD murmur is inconspicuous.

ECG

ECG shows right axis deviation. A large monophasic R-wave is present in V₁, with abrupt transition to a rS complex in V₂, V₃ and Rs complexes in V₅, V₆.

Chest X-ray

This shows a normal sized heart with a characteristic appearance termed as 'Coeur en Sabot' or 'boot shaped heart' (tilted apex). There is pulmonary oligoemia. Boot-shaped heart (Fig. 3.103) is due to the prominence of RV and concavity in the region is due to underdeveloped RVOT and main pulmonary artery.



Fig. 3.103: Boot-shaped heart



Complications

1. Marked secondary polycythaemia may result in intravascular thrombosis leading to cerebrovascular accidents and paradoxical emboli.
2. Cerebral abscess (common causative organism being Streptococcus) (Fig. 3.104).
3. Incidence of pulmonary tuberculosis and tuberculoma is high.

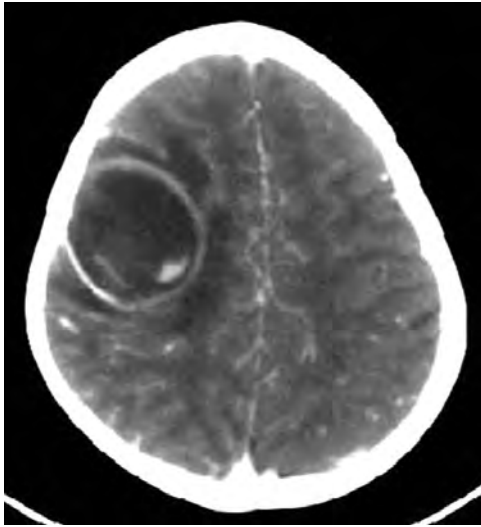

Fig. 3.104: Brain abscess in a TOF patient

4. Infective endocarditis (common causative organism being *Streptococcus*).
5. CCF is a rare complication and if present, may be secondary to
 - a. Infective endocarditis
 - b. Pregnancy
 - c. Anaemia
 - d. Systemic hypertension
 - e. Aortic regurgitation
 - f. Acquired calcific stenosis of the bicuspid aortic valve
 - g. Pulmonary atresia with large systemic arterial collaterals –RV failure
 - h. Accessory tricuspid leaflet occluding the VSD – RV failure.



Treatment

Medical

Treatment of cyanotic spells by

- a. squatting or knee chest position
- b. nasal O₂
- c. morphine
- d. β-blockers (propranolol).

Morphine and β-blockers (propranolol) help to relieve infundibular spasm.

Propranolol initially at the dose of 0.01 mg/kg IV followed by oral dose of 3-5 mg/kg/day is advocated. Morphine sulphate is given at the dose of 0.1mg/kg IV.

- e. Correct metabolic acidosis with sodium bicarbonate—1 mEq/kg IV.

Surgical

Total correction is advocated and is the definitive treatment.

If pulmonary arteries are excessively small, then early definitive correction of TOF is not possible and a palliative procedure (Blalock-Taussig shunt) is done till the time when the pulmonary arteries have enlarged sufficiently.

Blalock-Taussig Procedure: In left sided aortic arch— Left subclavian to left pulmonary artery. In right sided aortic arch—Right subclavian to right pulmonary artery.

This procedure results in absent radial pulse on the side of anastomosis and a continuous murmur at the site of anastomosis.

Waterston procedure: Ascending aorta to right pulmonary artery.

Pott's procedure: Descending aorta to left pulmonary artery.

Pulmonary Stenosis (PS)

Pulmonary stenosis may occur as an isolated defect or may accompany other anomalies, notably ventricular septal defect. It may occur at various levels (Fig. 3.105)

- a. Supravalvular
- b. Valvular
- c. Infundibular
- d. Subinfundibular.

Congenital stenosis of the valve presents as a dome-shaped diaphragm, consisting of fused cusps, with

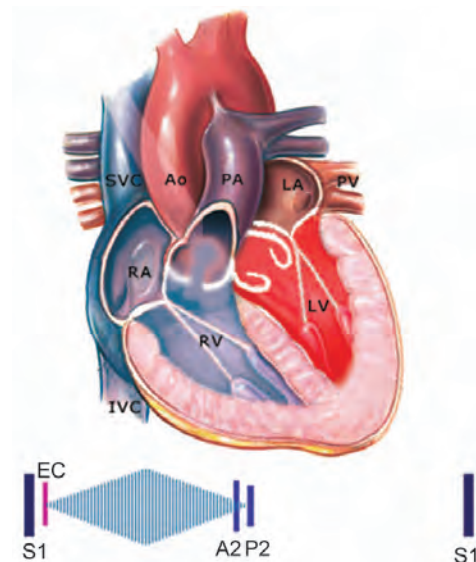

Fig. 3.105: Pulmonary stenosis



Assessment of Severity of Pulmonary Stenosis

Features	Mild	Moderate	Severe
1. Symptoms	Absent	Absent or minimal	Dyspnoea and fatigue
2. Central cyanosis	Absent	Absent	Present
3. Pulse	Normal volume	Normal volume	Small volume
4. JVP	Normal	'a'-wave prominent	Giant 'a'-wave seen
5. Parasternal heave	Grade I	Grade II	Grade III
6. Systolic thrill over pulmonary area	No thrill	Thrill may or may not be palpable	Thrill palpable
7. P ₂	Heard	Faint and delayed	Absent
8. Pulmonary ejection click	Prominent	Less prominent and occurs earlier (close to S ₁)	Very faint or absent
9. Duration and contour of ejection systolic murmur	Short duration of murmur with intensity peaking in early systole	Medium duration murmur with intensity peaking in mid-systole	Long duration of murmur with intensity peaking in late systole
10. Area of pulmonary valve orifice (normal area is 3–4 cm ²)	> 1 cm ²	0.8–1 cm ²	< 0.8 cm ²
11. Right ventricular systolic pressure (normal pressure is 25 mm Hg)	30–50 mm Hg	50–80 mm Hg.	> 80 mm Hg
12. Treatment	Medical	Medical or surgical	Surgical

small central aperture, and bulging into the pulmonary artery.

In infundibular stenosis, the infundibular impedance may consist of localised fibrous stricture or diffuse obstructive infundibular hypertrophy.

Supravalvular pulmonary stenosis occurs at the level of the pulmonary trunk, pulmonary arteries, or its peripheral branches. This is often a manifestation of the congenital rubella syndrome.

Concentric hypertrophy of the right ventricle occurs.

Reduced right ventricular compliance may raise right atrial pressure, enough to force open the foramen ovale, with resultant right-to-left shunt.

Marked pulmonary stenosis causes dyspnoea and fatigue, and central cyanosis may develop (secondary to right-to-left shunt across foramen ovale).

PS Associated Syndromes

1. Maternal rubella
2. Noonan syndrome (webbed neck, pectus excavatum, cryptorchidism).
3. Williams syndrome (Elfin facies, mental retardation, loquacious personality, coarse voice).
4. Foetal hydantoin syndrome.
5. Cutis laxa (generalised disruption of elastic fibres, diminished skin resilience, hernias)
6. Alagille syndrome (biliary hypoplasia, vertebral anomalies, prominent forehead, deep set ears)
7. LEOPARD syndrome (broad facies, basal cell naevi, rib anomalies and deafness).



Clinical Features

- A raised JVP, with prominent 'a'-wave.
- Lower left parasternal heave.
- Systolic thrill felt over pulmonary area.
- S₂ is widely split (mild PS).
- P₂ is soft and delayed, in valvular PS (in other types, P₂ is normal).
- Pulmonary ejection click may be heard, in valvular PS (other types not heard).
- Harsh, loud ejection systolic murmur heard over the pulmonary area, increasing in intensity with inspiration.

ECG

ECG shows right ventricular hypertrophy. RBBB may be seen.

Chest X-Ray

Right atrial and right ventricular enlargement. Prominence of the main pulmonary artery (poststenotic dilatation).



Complications

- i. Right ventricular failure
- ii. Infective endocarditis
- iii. Sudden death.



Treatment

Patients with mild stenosis do well with medical management, consisting of antibiotic coverage of bacteremic events, and with periodic examination.

Patients with severe stenosis warrant corrective surgery. Pulmonary balloon valvuloplasty is preferred. Other corrective surgeries are:

1. Pulmonary valvotomy
2. Pulmonary valve repair
3. Pulmonary valve replacement.

Differentiating Severity of Pulmonary Stenosis in Isolated Pulmonary Stenosis and Tetralogy of Fallot

In isolated pulmonary stenosis, the intensity of the murmur (ESM) across the stenosed pulmonary valve is directly proportional to the severity of stenosis. Hence, the more severe the stenosis, the louder the murmur and later is the peaking of its intensity.

In TOF, the intensity of the murmur (ESM), across the infundibular stenosis, is inversely proportional to the severity of stenosis. This occurs because as the infundibular stenosis becomes more severe, the blood is directed to the overriding aorta, thereby reducing the pulmonary blood flow and therefore also the intensity of the murmur.

Congenital Aortic Stenosis

It is one of the most common congenital defects in both children and adults.

Types

1. Supravalvular
2. Valvular
3. Subvalvular.

Both valvular and subvalvular aortic stenosis may be associated with:

- a. PDA
- b. VSD
- c. Coarctation of the aorta.

Supravalvular Aortic Stenosis (Williams Syndrome)

Features

- a. Supravalvular aortic stenosis (localised constriction immediately above the sinuses of Valsalva or a diffuse narrowing of the ascending aorta)

- b. Elfin facies (prominent forehead, widely spaced eyes, blunt upturned nose, underdeveloped mandible, dental hypoplasia and malocclusion, large mouth and patulous lips)
- c. Mental retardation
- d. Hypercalcaemia (due to vitamin D excess or intolerance).

Valvular Aortic Stenosis

This usually consists of a dome-shaped diaphragm with an eccentric aperture and fused commissures.

Poststenotic dilatation of the ascending aorta is common.

Subvalvular Aortic Stenosis

This consists of a fibrous or fibromuscular shelf encircling the outflow tract beneath the valve.

Congenital AS Associated Syndromes

Williams syndrome and fetal hydantoin syndrome.



Clinical Features

Congenital valvular stenosis causes physical findings similar to those of acquired valvular stenosis. The congenital valve remains flexible in contrast to the thick, calcified stenotic valve of acquired aortic stenosis. Hence, aortic ejection sounds and normal aortic closure sounds (A_2) are usually heard in congenital valvular stenosis. The harsh aortic ejection systolic murmur is heard.

Congenital subvalvular aortic stenosis causes clinical findings similar to those of valvular stenosis. Aortic regurgitation is more common and ejection sounds are not heard. The ejection systolic murmur is sometimes maximal along the mid or lower left sternal edge.

Congenital supravalvular aortic stenosis causes a harsh aortic ejection systolic murmur that occasionally is maximal in the first right interspace. Ejection sounds are not heard. Aortic regurgitation may be present. Systolic blood pressure is usually higher in the right arm than in the left arm, by approximately 30 mm Hg.

ECG

ECG shows left ventricular hypertrophy; occasionally congenital valvular stenosis is associated with partial or complete atrioventricular block.

Chest X-ray

CXR shows left ventricular enlargement. Poststenotic dilatation of the ascending aorta may be seen in valvular stenosis.

Rx Treatment

Treatment is surgical repair of the stenotic lesion obstructing the left ventricular outflow tract.

In case of intravalvular stenosis, the defect must be corrected immediately after its detection, as it may lead to progressive obstruction, valvular deformity and development of AR if uncorrected. AR may also develop as a result of infective endocarditis.

In supravalvular AS, surgery is recommended when aortic arch hypoplasia is less and when the obstruction is discrete and significant (gradient > 50 mm Hg).

In case of valvular aortic stenosis, corrective surgery may be performed only after the patient becomes symptomatic (develops angina, syncope or left ventricular failure) or when the patient develops left ventricular dysfunction, as evidenced by echo, whichever may be earlier. Surgery is in the form of valve replacement and this procedure is delayed as complications developing with a prosthetic valve (infective endocarditis) is more than with the native valve.

Coarctation of the Aorta (Figs 3.106 and 3.107)

In adults, coarctation of the aorta typically consists of a discrete, diaphragm-like ridge that extends into the aortic lumen in the region of the ligamentum arteriosum.

Post-ductal coarctation: Narrowing of the thoracic aorta immediately distal to the origin of the ductus and left subclavian artery.

Pre-ductal coarctation: Diffuse coarctation of the ascending aorta and transverse aortic arch, often in association with a hypoplastic left ventricle, aortic valve or mitral valve.

In this condition, upper half of the body is perfused via the systemic circulation, whereas flow to the lower

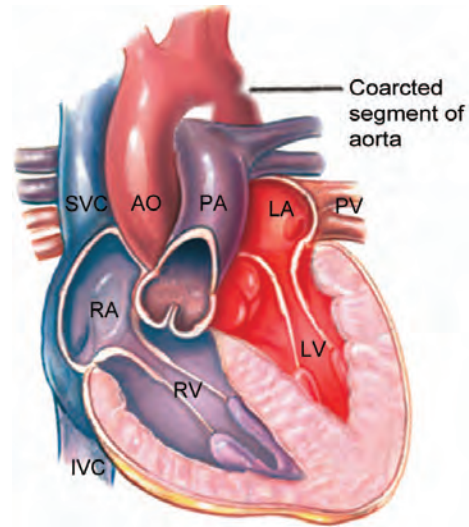

Fig. 3.106: Coarctation of aorta

half of the body comes from the pulmonary artery through a patent ductus arteriosus. This results in “differential cyanosis”, where the lower extremities are cyanotic.

Pseudocoarctation: Anatomically there is buckling or kinking of the aorta in the vicinity of ligamentum arteriosum but there is no gradient or development of systemic hypertension or collaterals.

Associated Cardiac Abnormalities

1. PDA
 2. Bicuspid aortic valve
 3. VSD.
- 85% of patients with COA have bicuspid aortic valve
 15% of patients with bicuspid aortic valve have COA

Coarctation of Aorta Syndromes

Turner syndrome, foetal hydantoin syndrome, Crouzon syndrome.

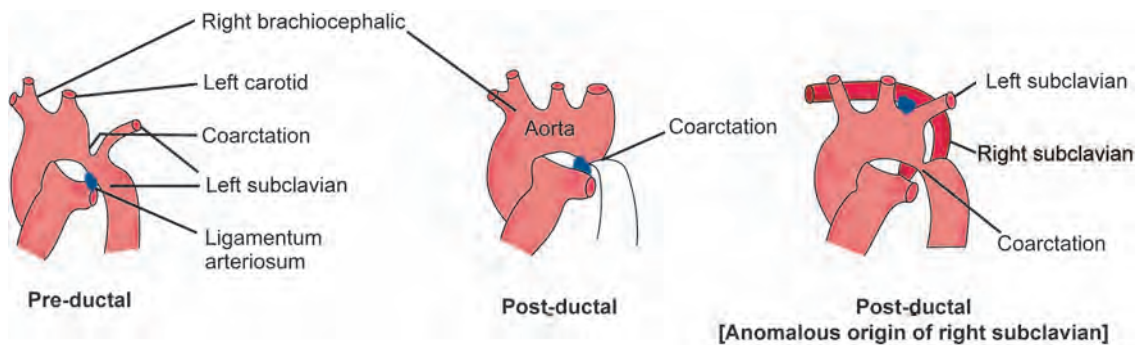

Fig. 3.107: Coarctation of aorta



Clinical Features

- Systolic arterial pressure is higher in the arms than in the legs, but the diastolic pressures are usually similar.
- In comparison to the radial or brachial pulses, the femoral pulses are weak and delayed.
- Systolic thrill may be palpable in the suprasternal notch and left ventricular enlargement may be present.
- A systolic ejection click often is audible (from a bicuspid aortic valve).
- A characteristic rough ejection systolic murmur may be audible along the left sternal border and in the back.
- A continuous murmur may be heard over the interscapular or infrascapular areas, indicating blood flow through collateral channels.
- Coarctation of the abdominal aorta may be associated with renal artery stenosis.

ECG

Evidence of left ventricular hypertrophy is seen.

Chest X-ray

Left ventricular enlargement is seen.

Notching of the ribs, due to increased collateral flow through the intercostal arteries, develops along the inferior and posterior aspect of 3rd to 8th ribs, bilaterally.

“Reversed E sign” (due to pre and poststenotic aortic dilatation and dilatation of the subclavian artery) (Fig. 3.108).

Fundus—Cork-screw appearance of retinal arteries.

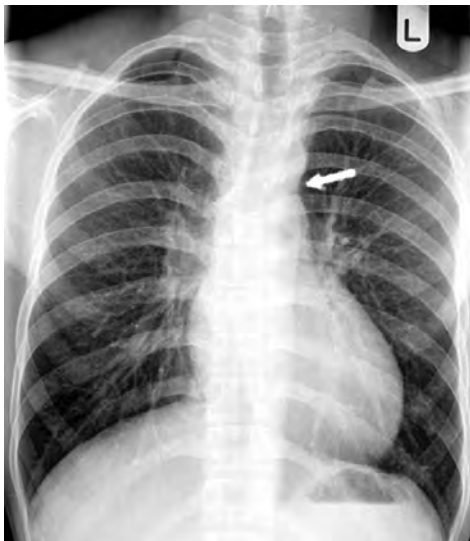

Fig. 3.108: Inverted ‘E’ sign

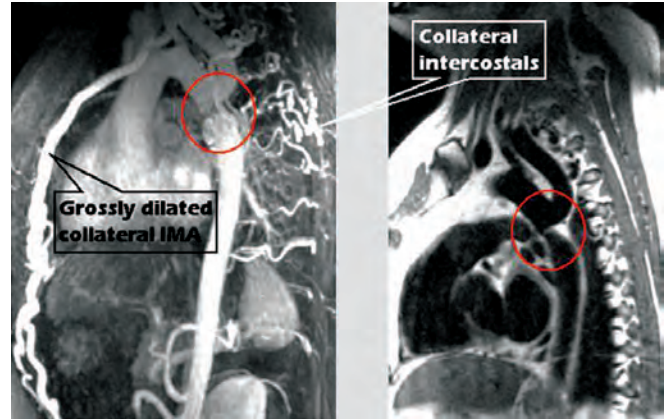

Fig. 3.109: MR angiography showing coarcted segment and collaterals



Complications

1. Bacterial endocarditis (at the site of the coarctation, bicuspid aortic valve or associated collateral channels) (Fig. 3.109).
2. Aortic dissection and rupture of the proximal ascending aorta may occur, sometimes during pregnancy.
3. Leak or rupture of a berry aneurysm (these patients have increased incidence of berry aneurysms of the circle of Willis).



Treatment

Medical treatment consists of control of hypertension. Surgical treatment consists of resection of the coarctation and reanastomosis or by aortoplasty. Elective surgery should be preferably performed at 4 to 5 years of age, since earlier surgical therapy is likely to result in restenosis of the aortic lumen and later repair may be associated with persistent hypertension.

Anomalous Pulmonary Venous Connection

The term anomalous pulmonary venous connection is used when any (in partial anomalous connection PAPVC) or all (in total anomalous connection—TAPVC) of the pulmonary veins drain into a site other than the left atrium.

TAPVC

In patients with TAPVC, the pulmonary veins may connect to a systemic vein within the thorax (supra-

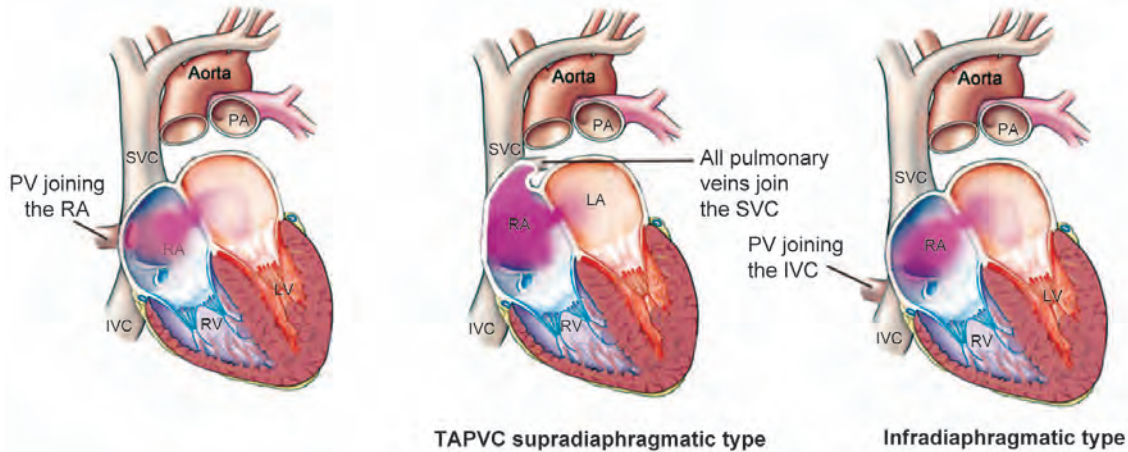

Fig. 3.110: Types of total anomalous pulmonary venous connection (TAPVC)

diaphragmatic) or portal vein in abdomen (subdiaphragmatic) (Fig. 3.110).

Associated Cardiac Malformations

1. Common atrium
2. Single ventricle
3. PDA
4. Pulmonary valve stenosis
5. Truncus arteriosus.

Clinical Features

- Almost all patients are cyanotic.
- Some patients may have a continuous murmur along the left sternal border due to flow through the anomalous pulmonary venous channels.
- Pulmonic component of S₂ is accentuated with development of PHT and the murmur becomes less marked or is even absent.
- Patients with TAPVC, with large left to right shunt, without pulmonary hypertension or pulmonary venous obstruction, show clinical findings resembling that of an uncomplicated ostium secundum ASD (except for the presence of cyanosis).

Chest X-ray

Snow man or figure of eight appearance (Fig. 3.111).

PAPVC

This implies that one or more (but not all) of the pulmonary veins are connected to the right atrium or its venous tributaries.

The right lung is involved 10 times more frequently than the left.



Fig. 3.111: Snow man appearance

An ASD generally accompanies PAPVC in 80 to 90% of the cases and is usually of the sinus venosus type.

It may be accompanied by hypoplasia of the right lung or dextroposition of the heart.

The physical findings in patient with PAPVC are similar to those of an ASD.

Treatment of TAPVC and PAPVC is total surgical correction.

Ebstein’s Anomaly

Ebstein’s anomaly is a congenital malformation involving the tricuspid valve, the right atrium and the right ventricle. The inferior and septal leaflets of the tricuspid valve are commonly rudimentary and dysplastic,

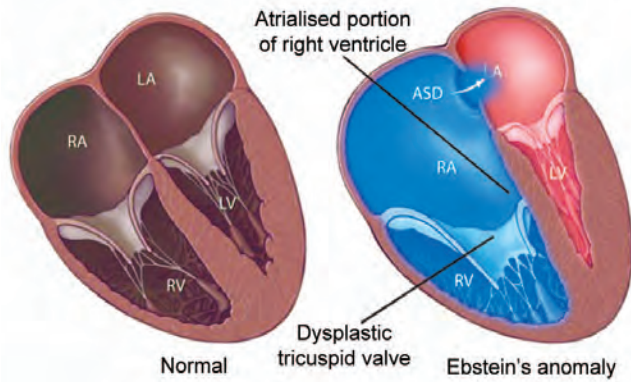

Fig. 3.112: Ebstein's anomaly

displaced apically and often adherent to the right ventricle, whereas the anterior leaflet is usually large, redundant and normally placed. Functionally, the tricuspid valve is regurgitant.

The displacement of the valve apparatus causes a portion of the right ventricle (in between the atrio-ventricular ring and the origin of the valve) to be "atrialised".

The right atrium is dilated, since it consists of a normal right atrium plus the atrialised portion of the right ventricle (Fig. 3.112).

Associated Cardiac Abnormalities

1. ASD or patent foramen ovale (seen in 50–75% of patients with resultant right-to-left shunt).
2. PS
3. Pulmonary atresia
4. VSD
5. Mitral valve prolapse.

Left-sided Ebstein's anomaly is common in corrected transposition of the great vessels (the anatomic right ventricle is left-sided and systemic as is the abnormal tricuspid valve).



Clinical Features

Many patients are asymptomatic until the third or fourth decade. They typically develop cyanosis, usually with exertion (intermittent cyanosis).

In the presence of central cyanosis, the absence of a right ventricular impulse strongly suggests Ebstein's anomaly or pulmonary atresia.

- The S_1 is typically loud and widely split (malformed tricuspid valve closes relatively late).

- The S_2 is widely split (due to presence of RBBB and delayed pulmonic valve closure).
- Multiple systolic clicks from the vibrations of the sail-like tricuspid anterior leaflet are often heard. The right-sided S_3 or S_4 may be heard.
- A murmur of tricuspid regurgitation is heard and is often accompanied by a scratchy diastolic murmur of tricuspid stenosis.



Diagnosis

The diagnosis of Ebstein's anomaly is most readily made by recording the intracardiac pressure and electrogram simultaneously with an electrode catheter. When this catheter is pulled from the right ventricle to the right atrium, right ventricular electrical potentials continue to be recorded after the pressure contour has changed from right ventricular to right atrial in form.

Chest X-ray

A globular heart (enlarged right atrium) with the narrow pedicle is seen, mimicking pericardial effusion (Fig. 3.113).



Fig. 3.113: Globular heart

ECG

Himalayan 'P' waves (giant, peaked 'P' waves), prolonged PR interval, incomplete or complete RBBB, wide QRS complex or type B-WPW syndrome (short PR interval and wide QRS) may be seen.



Treatment

Surgical correction.

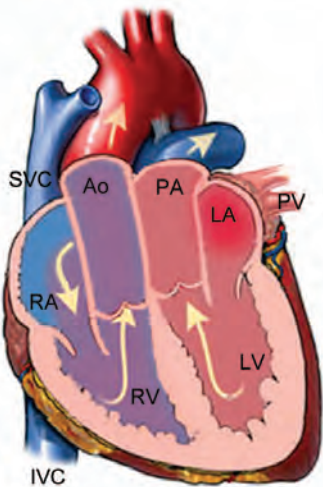

Fig. 3.114: Transposition of great vessels

Complete Transposition of the Great Vessels (D-transposition)

D-transposition of the great arteries is the most common cause of cyanotic congenital heart disease in the neonate, after TOF. It is a potentially lethal condition.

In complete transposition of the great vessels, the aorta arises from the morphologic right ventricle and lies anterior to the pulmonary artery, which originates from the morphologic left ventricle (Fig. 3.114).

Associated Cardiac Abnormalities

1. Virtually all patients have an interatrial communication (a patent foramen ovale or an ASD)
2. PDA (in two-thirds of patients)
3. VSD (in one-third of patients).

Infants with d-transposition of the great vessels are usually males, have increased birth weight and are more likely to have a diabetic mother.



Clinical Features

- Normal S_1 and single loud S_2 because of anteriorly placed aorta which masks P_2 .
- Associated murmurs of VSD, PDA or pulmonic stenosis.

ECG

Shows evidence of right ventricular hypertrophy.

Chest X-ray

Shows "egg-on-a-stalk" appearance (egg-shaped heart with narrow vascular pedicle) (Fig. 3.115).

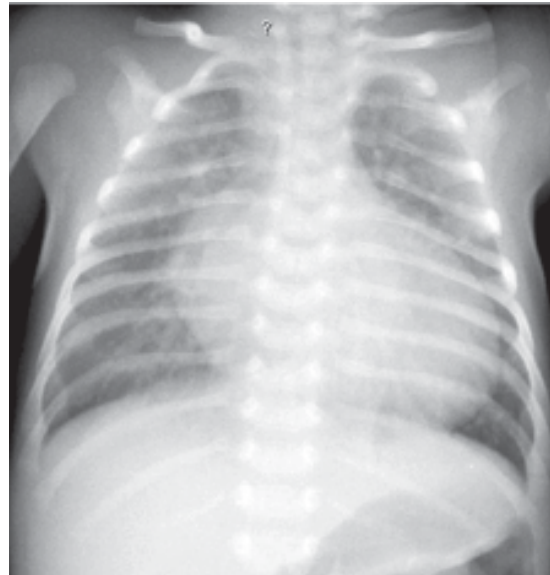

Fig. 3.115: Egg-shaped heart

The presence of pulmonary plethora in an infant with cyanosis strongly suggests a diagnosis of d-transposition of the great vessels.



Treatment

In the early neonatal period

- a. Prostaglandin E_1 infusion to dilate the ductus arteriosus
- b. Emergency enlargement of the interatrial communication by balloon atrial septostomy
- c. Anti-failure measures.
 - i. Definitive treatment is surgical ("arterial switch" operation)
 - ii. "Arterial Switch" operation – Jatene procedure. For older infants – "Atrial Switch" operation – Mustard or Senning procedure.

Congenitally Corrected Transposition of the Great Vessels

In the patient with congenitally corrected transposition of the great vessels, there is both atrioventricular discordance (the atria are connected to the opposite ventricles) and ventriculoarterial discordance (the ventricles are connected to the opposite great vessels).

It is also known as L-transposition of the great vessels, because the defect is formed when the primitive cardiac tube rotates to the left (levo- or l-ventricular loop) during embryogenesis, instead of its normal rightward rotation.



Associated Cardiac Abnormalities

1. VSD
2. Single ventricle
3. Left sided Ebstein's anomaly
4. Pulmonic or subpulmonic stenosis
5. Abnormal AV conduction system (seen in all patients).



Clinical Features

- S_1 may be reduced in intensity.
- S_2 is generally single and loud because of anteriorly placed aorta, which masks P_2 .

ECG

Disturbances of AV conduction, including PR interval prolongation, second degree AV block and even complete heart block may be seen.

Corrected transposition should be suspected in any young person with AV block.



Treatment

- Associated anomalies should be corrected
- Treatment of cardiac failure
- Prevention of infective endocarditis
- In the presence of symptomatic AV block, pacemaker insertion is indicated.

Truncus Arteriosus

Truncus arteriosus is an uncommon congenital anomaly in which a single common vessel forms the outflow tract for both ventricles and subsequently gives rise to the systemic, pulmonary and coronary arterial circulation.

It results from failure of the aorticopulmonary septum to form during embryogenesis.

It is always associated with a large supracristal VSD.

Three Types

- Type I Short pulmonary artery arises from the truncus and then branches into the right and left pulmonary arteries (most common).
- Type II Right and left pulmonary arteries may emerge directly from the posterior wall of the truncus.
- Type III Right and left pulmonary arteries may emerge directly from the lateral wall of the truncus.

Truncus arteriosus may be associated with

1. Increased pulmonary blood flow and minimal cyanosis
2. Decreased pulmonary blood flow and marked cyanosis
3. Near normal pulmonary blood flow and moderate cyanosis.

Di-George syndrome is associated with truncus arteriosus.



Clinical Features

- S_1 is normal followed by a systolic ejection click (from dilated solitary trunk).
- S_2 is loud and lacks splitting (the truncus valve is usually tricuspid and in 1/3rd, it is quadricuspid. Rarely, it is bicuspid).
- Ejection systolic murmurs are commonly heard.

ECG

Shows left ventricular volume overload and right ventricular pressure overload.

Chest X-ray

The combination of pulmonary plethora and presence of cyanosis is an important clue to the clinical recognition of truncus arteriosus.

There is gross cardiomegaly (bi-ventricular enlargement) and small or absent main pulmonary arterial segment.



Treatment

Surgical correction before 3 to 6 months of age.

Tricuspid Atresia (Fig. 3.116)

In this condition, the tricuspid valve is absent, the floor of the right atrium is intact and the systemic venous blood flows from the right atrium, through an interatrial septum, to the left atrium. There is nearly always, also, presence of a ventricular septal defect.

This malformation features two atria, a normal or enlarged left ventricle and a diminutive right ventricle.

Two Types

1. Tricuspid atresia with normally related great arteries
 - a. with pulmonary stenosis (common)
 - b. without pulmonary stenosis.

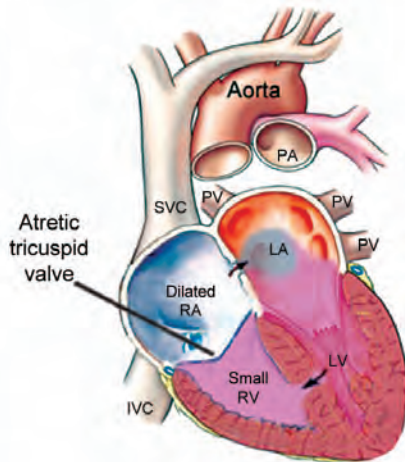

Fig. 3.116: Tricuspid atresia

2. Tricuspid atresia with transposed great arteries
 - a. with pulmonary stenosis
 - b. without pulmonary stenosis.



Clinical Features

- Central cyanosis (since birth).
- JVP shows prominent 'a'-wave.
- Prominent apical impulse and quiet left parasternal area.
- First and second heart sounds may be single.
- Systolic murmur often present.

ECG

Left axis deviation (since this axis is rare in other cyanotic conditions of childhood, it constitutes a valuable clue to the diagnosis of tricuspid atresia).

Chest X-ray

Heart shows the 'tilted' appearance (concavity of the left upper cardiac border due to decreased prominence of the main pulmonary artery and prominent convexity of the lower left border due to left ventricular enlargement).

Pulmonary oligoemia is seen.



Treatment

Surgical correction.

Congenital Complete Heart Block

Congenital complete heart block is characterised by severe bradycardia caused by atrioventricular

block that appears at the time of birth or in early childhood.

Anatomically the following defects may be seen:

1. Lack of communication between the atrial conduction system and AV node
2. Complete absence of the AV node
3. Degeneration and fibrosis of the AV node
4. Interruption of the connection between the AV node and bundle of His
5. Disruption of the His bundle.

Aetiology

Congenital complete heart block, on occasion, is associated with:

- a. an infection *in utero*
- b. maternal inflammatory disorder, such as connective tissue disease (discoid lupus, SLE or rheumatoid arthritis).

Associated Cardiac Abnormalities

1. Corrected transposition of the great vessels
2. ASD
3. VSD.

Most of the patients are relatively asymptomatic for years, since the junctional escape rhythm is under autonomic control and therefore the heart rate can increase with exertion or stress.



Complications

1. Bradycardia
2. Stokes-Adams attacks (syncope)
3. CCF
4. Sudden death.

Factors Identifying High Risk Patients

1. Persistently low resting heart rate
2. Associated cardiac abnormalities
3. Prolonged QT interval
4. Wide QRS complex
5. Ventricular arrhythmias.



Treatment

Severe bradycardia, causing symptoms, necessitates the insertion of a permanent pacemaker.



Differentiation between Congenital and Acquired Complete Heart Block

Congenital complete heart block	Acquired complete heart block
1. Appears at the time of birth or in early childhood	Seen in adults
2. Anatomic discontinuity may be at several levels of conduction system	Discontinuity is at the level of AV node
3. Secondary to infection <i>in utero</i> or a maternal connective tissue disease	Secondary to ischaemic heart disease or degeneration
4. May be associated with other cardiac abnormalities	Usually not associated with other cardiac abnormalities
5. Relatively asymptomatic for years	Become symptomatic early
6. Heart rate 40–60 per minute	Heart rate less than 40 per minute
7. Heart rate can increase with exertion or stress (as junctional escape rhythm is under autonomic control)	Heart rate does not increase with exertion or stress (as junctional escape rhythm is not under autonomic control)
8. Stokes-Adams attacks are rare	Stokes-Adams attacks are common

Idiopathic Dilatation of the Pulmonary Artery

Idiopathic dilatation of the pulmonary artery is a relatively uncommon congenital defect characterised by a congenital dilatation of the main pulmonary trunk.

This may be associated with pulmonic regurgitation or progressive dilatation and aneurysm formation.

It is usually asymptomatic and its clinical importance lies in its recognition and distinction from other conditions, such as ASD, PS and severe PHT.



Clinical Features

- Precordium frequently shows a visible and palpable systolic impulse in the second left intercostal space, particularly when breath is held in expiration.
- No evidence of right ventricular impulse.
The presence of a right ventricular impulse is incompatible with a diagnosis of idiopathic dilatation of the pulmonary artery, since this condition causes neither pressure nor volume overload of the right ventricle.
- S_1 is normal followed by a pulmonic ejection click.
- A short systolic ejection murmur and a decrescendo diastolic murmur of pulmonic regurgitation may be present.
- The pulmonic component of the S_2 is frequently accentuated.

- In some patients S_2 may be widely split, suggesting a diagnosis of ASD (due to delayed elastic recoil of the dilated pulmonary trunk).

ECG

Usually normal.

Chest X-ray

Shows dilatation of the main pulmonary artery.



Treatment

No specific therapy is indicated.

Congenital Abnormalities of the Coronary Arteries

These are seen in 1 to 1.5 percent of patients and may be of the following types:

1. Coronary arteriovenous fistulae
2. Origin of a coronary artery from the pulmonary artery
3. Aberrant origin of one or both coronary arteries from the aorta.

Coronary Arteriovenous Fistula

It is a communication between a coronary artery and a cardiac chamber. The fistula most commonly arises from the right coronary artery or its branches and usually drains into the right ventricle, right atrium or coronary sinus.

It results in a left-to-right shunt that is usually small, so that coronary blood flow is rarely compromised.

Patients are generally asymptomatic.

A continuous murmur (mimicking a PDA) is heard at the lower or midsternal border or entire precordium.



Complications

1. Infective endocarditis
2. Pulmonary hypertension (if shunt is large)
3. Rupture or thrombosis of fistula
4. Myocardial ischaemia.



Diagnosis

Diagnosis is by coronary arteriography.



Treatment

Surgical closure of fistula.



Anomalous Origin of a Coronary Artery from the Pulmonary Artery

This may involve either the main right or left coronary arteries or their branches. Left main coronary artery is commonly involved.

Coronary arteries involved in order of descending frequency are:

- The left main coronary artery
- The right coronary artery
- The anterior descending coronary artery
- The circumflex coronary artery.

Symptoms may be of

- Myocardial ischaemia
- CCF
- Mitral regurgitation (ischaemic injury to papillary muscle).

Sudden death may occur.



Clinical Features

- A loud continuous murmur along the sternal border or at the base.
- A mitral regurgitation murmur and an S₃ may be heard.

ECG

Shows ischaemic injury with poor R-wave progression over the anterior precordium. Definitive diagnosis is made with selective arteriography of the coronary artery.



Treatment

By surgical correction.

Rheumatic Fever

Acute, recurrent, inflammatory disease, mainly of children (aged 5–15 years), typically occurring 1–5 weeks after group A streptococcal infection.

Pathophysiology

1. Cross reactivity of host antistreptococcal antibodies to cardiac antigens
2. Microbe initiated autoimmune reactivity.

Jones Criteria for Diagnosis of Rheumatic Fever

Major Criteria

Carditis

Pancarditis, seen in 50–60% of patients, develops within the first 2 weeks of rheumatic fever. Pericarditis is

evidenced by presence of a pericardial rub, myocarditis by tachycardia, soft S₁, presence of S₃ and CCF and endocarditis by the presence of Carey-Coombs' murmur (mitral diastolic murmur).

Arthritis (60-75%)

Flitting and fleeting type of polyarthritis involving large joints with no residual deformity is seen in 60–75% of patients and occurs early in rheumatic fever.

Jaccod's arthritis: Ulnar deviation of 4th and 5th finger with flexion at metacarpophalangeal joints is the only residual deformity seen in rheumatic polyarthritis.

Subcutaneous Nodules

Non-tender nodules are seen over bony prominences like elbows, shin, occiput, spine in 3–5% of patients and occur 3–6 weeks after onset of rheumatic fever. Patients who have subcutaneous nodules almost always have carditis.

Erythema Marginatum (< 5% and evanescent)

Macular lesions with an erythematous rim and central clearing in a bathing suit distribution are seen in < 5% of patients and occur early in rheumatic fever.

Chorea (Sydenham's Chorea) (2-30%)

A neurological disorder with rapid, involuntary and purposeless non-repetitive movements with a self limiting course of 2–6 weeks is more common in females and is a late manifestation of rheumatic fever.

Minor Criteria

Clinical

1. Fever
2. Arthralgia
3. Previous history of rheumatic fever or rheumatic heart disease.

Laboratory

1. Acute phase reactants (leucocytosis, raised ESR, C-reactive protein)
2. Prolonged PR interval in ECG (> 0.2 sec).

WHO Criteria

Jones major and part of the minor criteria except prior history of rheumatic fever/rheumatic heart disease and C-reactive protein.

Essential Criteria

Evidence for recent streptococcal infection as evidenced by:



1. Increase in ASO titre
 - a. > 333 Todd units (in children)
 - b. > 250 Todd units (in adults).
2. Positive throat culture for streptococcal infection.
3. Recent history of scarlet fever.

Two major (or) one major and two minor criteria, in the presence of essential criteria, is required to diagnose Acute Rheumatic Fever.

A Positive Rheumatic Fever history is usually elicited in only 50% of patient with Rheumatic Heart Disease.

Valve Involvement in Rheumatic Heart Disease

Mitral valve alone	50%
Aortic valve alone	15–20%
Mitral and Aortic valves together	35–40%
Mitral, Aortic and Tricuspid valves	2–3%
Pulmonary valve is virtually never involved.	

In RHD, mitral valve is most commonly involved followed by involvement of the aortic valve as the pressure gradient across the mitral valve is the greatest, followed by that across the aortic valve. So, the mitral valve is more susceptible to develop pathological changes than the aortic valve.



Treatment

- a. Tab aspirin 75–100 mg/kg/day in 4–5 divided doses, till the activity of the disease subsides (ESR becomes normal).
- b. Steroids in dose of 1–2 mg/kg/day if symptoms of RF and/or carditis persist despite adequate aspirin therapy.
- c. Continuous prophylaxis against recurrent RF with inj. benzathine penicillin 1.2 million units IM every 3–4 weeks. In patients allergic to penicillin, tab. sulfadiazine 1 gm daily or tab. erythromycin 250 mg twice daily may be given. Prophylaxis must continue, up to the age of 25 years or 5 years after the last attack, whichever is longer.

Prevention of Rheumatic Fever

Primary prevention:

Benzathine penicillin—Once only
 < 27 kg 6,00,000 Units
 > 27 kg 12,00,000 Units

Penicillin -V

Children—250 mg tid for 10 days

Adolescents/Adults—500 mg tid for 10 days

For penicillin allergic patients:

Erythromycin 40 mg/kg/day-tid/qid for 10 days

Secondary prevention:

Benzathine penicillin—12,00,000 Units IM—Every 3/4 weeks

Penicillin-V—250 mg bid daily

Sulphadiazine—< 27 kg - 0.5 g; > 27 kg - 1 g once daily

Duration of treatment:

Rheumatic fever with no carditis—5 years or until the age of 18 years (whichever is longer).

Rheumatic fever with carditis without valvular lesion—10 years or until the age of 25 years (whichever is longer).

Rheumatic fever with carditis with valvular lesions—life long.

Valvular Heart Disease

Mitral Stenosis (MS) (Fig. 3.117)



Causes

1. Rheumatic heart disease
2. Congenital—parachute mitral valve
3. Hunter's syndrome
4. Hurler's syndrome
5. Drugs—methysergide
6. Carcinoid syndrome
7. Amyloidosis
8. Mitral annular calcification
9. Rheumatoid arthritis
10. Systemic lupus erythematosus
11. Infective endocarditis with large vegetations.

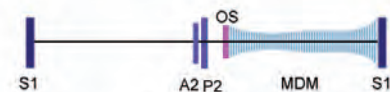
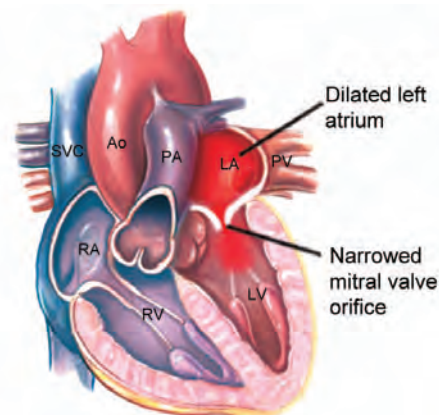

Fig. 3.117: Mitral stenosis



Symptoms

Dyspnoea, palpitation, fatigue, haemoptysis, recurrent bronchitis.

Signs

- Mitral facies (malar flush)
- Malar flush: Cyanotic cheek with slight telangiectasia. (Other causes - PS, ASD, Carcinoid)
- Small volume pulse
- Left parasternal heave
- Tapping apical impulse (palpable S_1)
- Palpable P_2
- Diastolic thrill over mitral area
- Loud S_1 , opening snap (indicate pliability of valve)
- A low pitched, rough, rumbling, mid-diastolic murmur with pre-systolic accentuation, best heard over the apex, with the bell of the stethoscope in the left lateral position, in expiration.
- MS murmur is accentuated by mild exercise.
- Murmur disappears in severe MS due to decreased cardiac output
- With the development of pulmonary hypertension, an ESM may be heard over the pulmonary area and a PSM which increases on inspiration, may be heard along the left sternal border (functional TR).

Asymptomatic MS

Physical signs of MS are often found before symptoms develop and their recognition is of particular importance in pregnancy.

Severity

According to valve area and symptoms.

Normal Mitral Valve Area is 4–6 cm²

Valve area	Symptoms
> 2.5 cm ²	None
1.5–2.5 cm ² (Mild MS)	Dyspnoea on severe exertion
1–1.5 cm ² (Moderate MS)	PND ± pulmonary oedema
< 1 cm ² (Severe/critical MS)	Orthopnoea (class IV)

According to A_2 -OS Interval

In severe MS, A_2 -OS interval becomes shortened. In severe MS, it is 0.05–0.07 sec and in mild MS, it is 0.10–0.12 sec.

According to the Gradient Across Stenotic Mitral Valve

Normal valve gradient is 0 mm Hg

Stenotic gradient

Mild MS	< 5 mm Hg
Moderate MS	5 to 15 mm Hg
Severe MS	> 15 mm Hg

Duration of the diastolic murmur is directly proportional to the severity.



Complications

Haemoptysis

- Pulmonary apoplexy due to rupture of thin-walled, dilated broncho-pulmonary veins usually as a consequence of a sudden rise in left atrial pressure.
- Blood stained sputum associated with episodes of PND due to pulmonary congestion.
- Pink, frothy sputum of pulmonary oedema.
- Blood stained sputum as a result of recurrent bronchitis and bronchiectasis
- Pulmonary infarction, a late complication of MS associated with heart failure
- Anticoagulants
- Lobar and bronchopneumonia
- Pulmonary haemosiderosis.

Atrial Fibrillation (AF)

- Two thirds of patients with MS, have AF
- AF is more common in MS than in MR
- With AF, pulse becomes irregularly irregular
- There are no 'a'-waves in JVP and intensity of S_1 is variable.
- AF may precipitate CCF and thromboembolic episodes. Emboli may reach cerebral, peripheral, renal and coronary vessels.

Thromboembolic episodes are more common in elderly and severe MS with low cardiac output.

Pulmonary Oedema

This occurs when there is a sudden surge in flow across a markedly narrowed mitral valve, when the LA pressure is more than 25 mm Hg (in the early phase of MS). Pulmonary oedema is less common in long-standing MS because of thickening of alveolar capillary membrane.

Infective Endocarditis

This occurs less commonly in patients with isolated MS than in patients with associated MR. With isolated MS, it occurs more frequently in mild MS with pliable valves and less frequently in severe MS with rigid, calcified and thickened valves.



Chest Pain

Anginal pain may be due to coincidental coronary atherosclerosis or secondary to coronary embolisation. Angina like pain occurs in severe pulmonary hypertension due to hypoxia, hypotension and reduced cardiac output.

Pressure Symptoms

- Compression of left recurrent laryngeal nerve by enlarged left atrium, tracheobronchial lymph nodes and dilated pulmonary artery results in hoarseness of voice (Ortner's syndrome).
- Pressure on left main bronchus may result in bronchiectasis.
- Rarely erosion of spine may occur causing paraplegia.

Pulmonary Haemosiderosis and Ossification

It may occur in long-standing pulmonary hypertension.

Conditions Simulating MS

- Left atrial myxoma
- Cortriatriatum
- Ball valve thrombus of left atrium
- Diastolic flow murmurs across normal mitral valve as in VSD, PDA, severe MR, etc.
- Carey-Coomb's murmur of mitral valvulitis.
- TS (also masks the features of MS)
- Austin-Flint's murmur

Atrial Myxoma

It may present with fever, anaemia, weight loss, clubbing, systemic emboli, increased IgG and IL-6.

ECG

- 'P' mitrale (left atrial enlargement) and RVH.
- Features of atrial fibrillation (absent 'P'-waves and varying RR intervals).

Chest X-ray

- Left atrial enlargement (double shadow behind the heart in right heart border—shadow within shadow).
- Splayed carina.
- Straightening of the left heart border (Fig. 3.118) (due to prominent pulmonary artery and LA appendage).
- Later, mitral valve calcification (Figs 3.119 and 3.120).
- Kerley B lines (dense, short, horizontal lines most commonly seen in the costophrenic angles when pulmonary venous pressure is between 20–30 mm Hg).

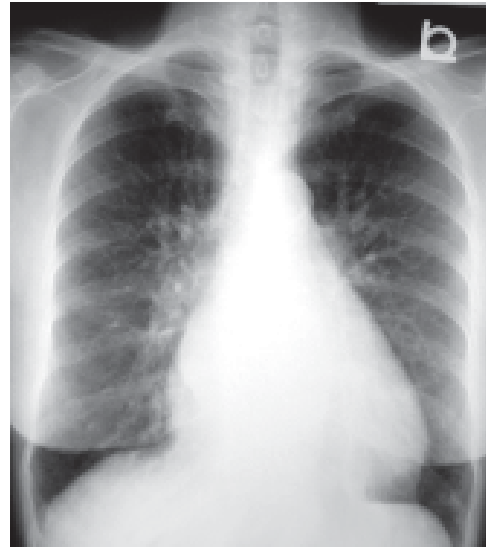

Fig. 3.118: X-ray showing straightened left heart border

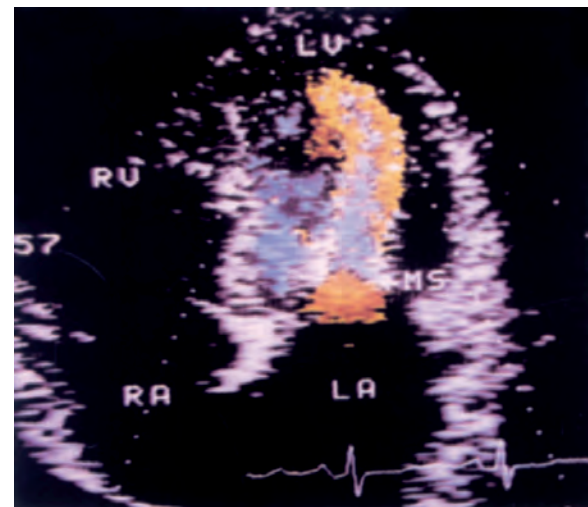

Fig. 3.119: Mitral stenosis—candle flame jet

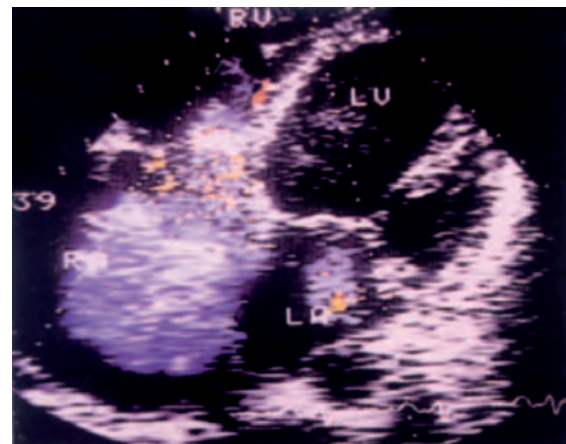

Fig. 3.120: Right atrial myxoma with mild mitral and tricuspid regurgitation

- Kerley A lines (Straight, dense lines up to 4 cm in length and running towards the hilum when pulmonary venous pressure is more than 30 mm Hg).
- Rarely, findings of pulmonary haemosiderosis and parenchymal ossification.
- Barium swallow in RAO view may demonstrate sickling of barium filled oesophagus due to compression by enlarged LA.

Echocardiogram

Thickened immobile cusps; reduced rate of diastolic filling; reduced valve area.

Cardiac Catheterisation

Pressure gradient between LA (or pulmonary wedge) and LV; useful in assessing co-existent MR and coronary disease.

Coronary angiogram is indicated in all males > 45 years and females > 55 years or young persons with evidence of IHD before mitral valve surgery to rule out CAD.



Management

Medical

1. Antifailure measures
2. Anticoagulation in atrial fibrillation and treatment of AF
 - Use digoxin, verapamil, or beta-blockers in AF to reduce the ventricular rate.
3. Rheumatic fever prophylaxis
4. Infective endocarditis prophylaxis.

Surgical

Four modalities of surgery are available:

1. Closed mitral valvotomy/commissurotomy (without cardiopulmonary bypass).
2. Open mitral valvotomy/commissurotomy (with the aid of cardiopulmonary bypass).
3. Percutaneous balloon valvuloplasty.
4. Mitral valve replacement.

Closed Mitral Valvotomy/Commissurotomy

Preferred in patients with pliable valve and when there is no associated MR. This is done with the aid of TUBBS transventricular dilator or transatrial finger fracture.

Open Mitral Valvotomy/Commissurotomy

Open mitral valvotomy is done for patients with pure MS who have not been operated upon previously. In

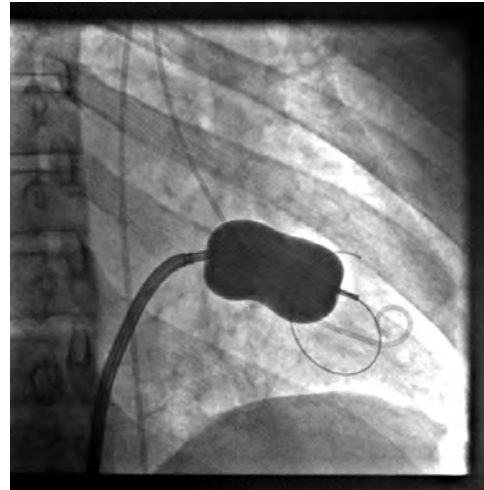

Fig. 3.121: Balloon mitral valvuloplasty

addition to opening the valve commissures, any subvalvular fusion of papillary muscles and chordae tendinae are loosened and calcium deposits are also removed. Thrombi, if present, are removed from LA and its appendage and the latter is often amputated to remove a potential source of post-operative emboli.

Following this procedure, patient can survive for 5 to 15 years. This is preferred to valve replacement in young patients with MS.

Percutaneous Balloon Valvuloplasty

It is useful in pregnant women with MS and also for older patients with severe valvular deformity and other extracardiac disease who are poor operative candidates (Fig. 3.121).

This procedure is similar to that of closed mitral valvotomy except that the hospital stay is minimised and there is no scar.

Criteria for Valvuloplasty

1. Significant symptoms
2. Isolated MS
3. No (or trivial) MR
4. Mobile, non calcified valve/sub valve apparatus
5. LA free of thrombus.



Complications of Valvuloplasty

1. Embolic events
2. Cardiac perforation (0–4%)
3. Development of MR
4. Iatrogenic, residual ASD which later closes or decreases in size.



Valve Replacement

When there is associated MR or when the valve is rigid and calcified, valve replacement is indicated. Valve replacement is done using:

Mechanical Prosthesis

- Caged ball valve (*Starr-Edwards prosthesis*)
- Tilting-disc valve (*St Jude, Bjork-Shiley valves*).

Bioprosthesis

- Porcine bioprosthesis
- Pericardial xenograft prosthesis.
- Homografts—Autograft with pulmonary valve in cases of aortic valve IE or allografts from cadaveric valves.

Among the mechanical prosthesis, tilting-disc valve is preferred to caged ball valve because:

- It occupies less space and hence useful in patients with a small left ventricle
- Incidence of haemolysis is less common
- Incidence of strut fractures is less common.

Life long anticoagulation is indicated in patients receiving mechanical prosthesis.

The advantage of bioprosthetic valve is the low incidence of thromboembolic phenomenon. Bioprosthetic valves are not usually used in young patients < 65 years because of its rapid deterioration. However, they are useful in pregnancy, when there is contraindication to the use of anticoagulants and also in older patients over 65 years of age.

Mitral Regurgitation (MR) (Fig. 3.122)



Causes

- Rheumatic heart disease
- Congenital MR (parachute mitral valve, endocardial cushion defects, mitral valve prolapse syndrome)
- Infective endocarditis of chordae or valve
- Ischaemic heart disease (papillary muscle dysfunction, infarction, rupture)
- Cardiomyopathy (LV dilatation)
- Injury, surgery
- Connective tissue disorders
 - Ankylosing spondylitis
 - Rheumatoid arthritis
 - Systemic lupus erythematosus

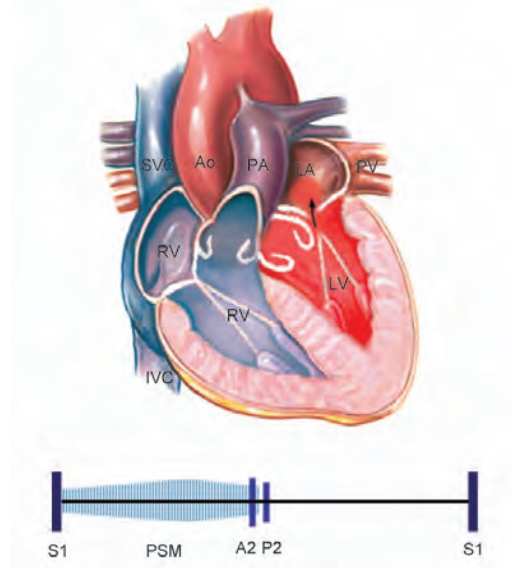

Fig. 3.122: Mitral regurgitation

Marfan's syndrome
Ehlers-Danlos syndrome

- Amyloidosis
- Sarcoidosis
- Extensive mitral annular calcification (Renal disease, elderly woman, DM, HTN)
- Cleft mitral leaflets with ostium primum ASD.

Symptoms

Dyspnoea, fatigue, palpitation (in AF).

Signs

- Wide pulse pressure
- Hyperdynamic apical impulse which is shifted down and out
- Parasternal lift
- Soft S₁
- S₃ over apex
- P₂ loud and S₂ widely split in pulmonary hypertension (Widely split S₂ is due to pre-mature aortic valve closure).
- MR murmur (not due to MVP) is increased by hand grip and decreased during straining phase of valsalva
- S₄ is heard only in acute MR
- Systolic thrill over mitral area
- A pansystolic murmur at apex, radiating to axilla and back if anterior leaflet is involved or to base if posterior leaflet is involved.

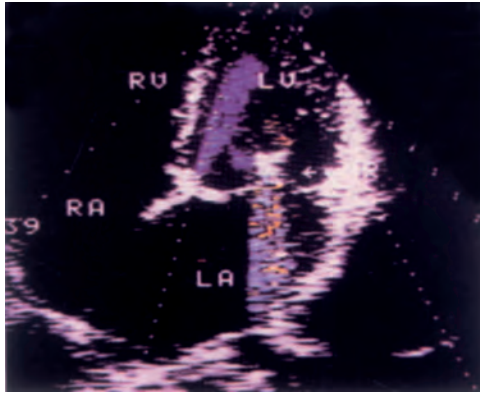

Fig. 3.123: Mitral regurgitation

- Signs of AF—AF is better tolerated and less common in MR than in MS; A systolic murmur heard over the apex may be either due to MR or AS. With the development of AF, systolic murmur of AS changes from beat to beat whereas murmur of MR remains unchanged (Fig. 3.123).

Diastolic MR

In acute aortic regurgitation, the pressure in the left ventricle may rise rapidly during diastole to high levels resulting in regurgitation of blood into the left atrium.

Severity

The following indicate severity of MR:

- Presence of systolic thrill over apex
- Large LV indicates severe MR
- Presence of S_3
- Flow MDM across non-stenotic mitral valve indicates severe MR.



Complications

1. AF may result in thromboembolism
2. Infective endocarditis (more common than in MS).

ECG

'P' mitrale; LV enlargement; sometimes AF.

Chest X-ray

- Cardiomegaly (due to left atrial, left ventricular and later right ventricular enlargement)
- Calcification of annulus or leaflets
- Signs of pulmonary venous hypertension and pulmonary oedema.

Echocardiogram

Dilated LA (giant or aneurysmal left atrium) and LV; Dynamic LV (unless LVF predominates); Regurgitation detectable.

Cardiac Catheterisation

Dilated LA, LV; mitral regurgitation demonstrated; pulmonary hypertension may be present.



Management

Medical

Same as for MS.

ACE inhibitors are useful in the treatment of chronic MR. Intravenous nitroprusside or nitroglycerine reduce the afterload and thereby the volume of regurgitant flow and thus useful in stabilising patients with acute and or severe MR.

Diuretics and intraaortic counter pulsation are useful in acute MR.

Surgical

- *Indication for surgery* – LV end-systolic dimension of > 45 mm or LVEF $< 60\%$ denotes severe LV dysfunction

Surgery is indicated when there is progressive deterioration in LV function despite antifailure measures.

- Plastic reparative procedure of mitral valve (in young patients).
- Valve replacement in older patients.



Causes of Acute MR

1. Infective endocarditis
2. Trauma
3. Acute rheumatic fever
4. Myocardial infarction (rupture of papillary muscle especially in inferior wall MI)
5. Myocardial abscess
6. Prosthetic valve endocarditis
7. Left atrial myxoma
8. Connective tissue disorders
9. Myxomatous degeneration of the valve.

Surgery for Acute MR

- Failure of medical therapy to stabilise the patient in acute MR
- Stable MR in infective endocarditis surgery is delayed till the completion of antibiotic therapy



(If unstable immediate surgery under antibiotic coverage).

- Recent onset of AF
- Pulmonary hypertension > 50 mm of Hg
- LV end systolic dimension > 40 mm
- LVEF < 60 %

Emergency surgery is indicated in case of papillary muscle rupture.

Difference between Acute MR and Chronic MR

Features	Acute MR	Chronic MR
Symptoms	Sudden onset of dyspnoea, PND, orthopnoea	Gradual onset of symptoms
<i>Signs:</i>		
Apex beat	Unremarkable	Displaced and dynamic
First heart sound	Soft	Normal/Soft
Murmur	Early/Holosystolic	Holosystolic
Fourth heart sound is heard mainly in the MR of recent onset.		
ECG	Normal except in acute myocardial ischaemia	Left atrial enlargement (P-mitrale), Atrial fibrillation, LVH
Radiology and Fluoroscopy	Heart size—Normal	Cardiomegaly (LVH); left atrial enlargement; on fluoroscopy, calcium on valve leaflets
ECHO	Cause of acute MR may be demonstrated (Flail leaflet, ruptured chordae or vegetations)	Cause of chronic MR may be defined

Mitral Valve Prolapse Syndrome (MVPS) (Fig. 3.124)

MVPS is also known as systolic click—murmur syndrome, Barlow syndrome, floppy valve syndrome. Also known as billowing mitral leaflet syndrome.

There is excessive or redundant mitral leaflet tissue, with myxomatous degeneration and increased concentrations of acid mucopolysaccharide.

Posterior leaflet is commonly involved. Involvement of anterior leaflet alone is very rare.

Conditions Causing or Associated with MVP

- Idiopathic/Unknown (in majority)
- Genetically determined collagen tissue disorder
- Marfan's syndrome
- Acute rheumatic fever

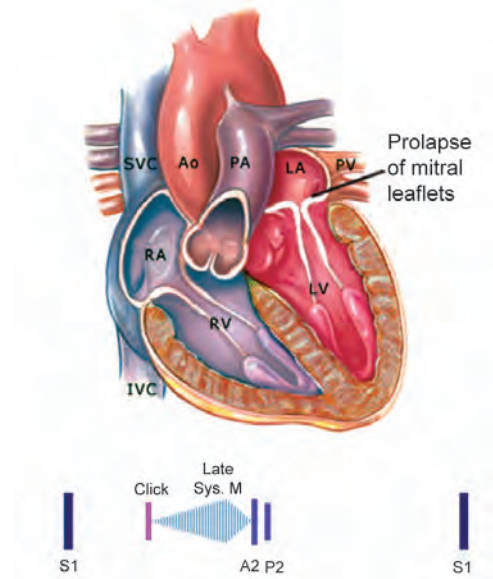

Fig. 3.124: Mitral valve prolapse

- Chronic rheumatic heart disease
- Following mitral valvulotomy
- Ischaemic heart disease
- Cardiomyopathies
- Ostium secundum ASD
- Trauma
- LV aneurysm
- Connective tissue disorders
- Ehler-Danlos syndrome
- Osteogenesis imperfecta.

MVP is more common in females; MVP may present with only a systolic click and murmur with a mild prolapse of the posterior leaflet or with severe MR.

MVP is the most common cause of isolated severe MR.

Symptoms

- Palpitations (due to tachyarrhythmias)
- Chest pain.

Signs

A mid or late systolic click (about 0.14 sec after S₁) due to sudden tensing of slack, elongated chordae tendineae or by prolapsing mitral valve which reaches its maximum excursion. Clicks may be multiple due to scalloping of the redundant mitral valve.

A high pitched late systolic crescendo-decrescendo murmur (whooping or honking) heard best at the apex.

Click and murmur occur earlier with standing (decreased LV volume); squatting and isometric exercise (increased LV end diastolic volume) delay the click and murmur and may even make them disappear.

Complications

- Transient cerebral ischaemic attacks (due to emboli from mitral valve)
- Infective endocarditis when MVP is associated with MR.

ECG

Bi-phasic or inverted 'T'-waves in leads II, III and aVF and occasional supraventricular or ventricular extrasystole.

Echocardiogram

Useful in identifying the abnormal position and prolapse of the mitral valve leaflets. Mitral valve prolapse is diagnosed when systolic displacement of mitral leaflets > 2 mm into the left atrium with coaptation superior to the plane of mitral annulus (Fig. 3.125).

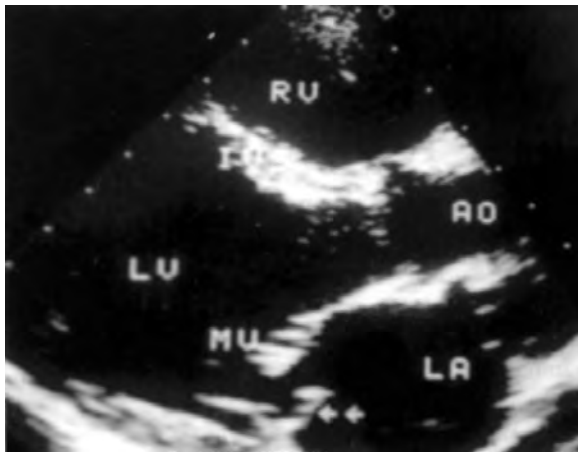

Fig. 3.125: Mitral valve prolapse—flail posterior mitral leaflet pointing towards left atrium

Management

Medical

- Reassurance
- Prevention of infective endocarditis, when there is MR
- Beta blockers for chest pain and tachyarrhythmias
- Antiarrhythmic agents for VPC's and tachyarrhythmias

- Aspirin for TIA
- Anticoagulation therapy – Warfarin.

Surgical

When MR becomes severe, either reconstruction or valve replacement may be done.

Most common cause of combined mitral stenosis and mitral regurgitation is rheumatic heart disease.

Aortic Stenosis (AS) (Fig. 3.126)

Common Causes

- Congenital aortic stenosis (supravalvular AS, valvular AS, subvalvular AS)
- Rheumatic aortic stenosis
- Degenerative (senile) calcific aortic stenosis
- Atherosclerotic aortic stenosis (common after 65 years).

Patients with rheumatic aortic stenosis almost always have concomitant mitral valve involvement.

Symptoms

Angina, dyspnoea, syncope, dizziness, sudden death (may be as a result of intolerance to complete heart block or atrial tachyarrhythmia).

Pure aortic valve disease may remain asymptomatic for 10–15 years.

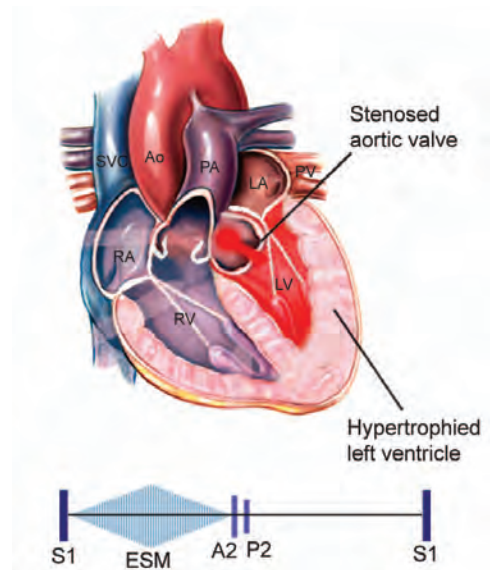

Fig. 3.126: Aortic stenosis



Signs

- Slow rising, small volume pulse
- Heaving apex beat
- S_4 may be heard
- Ejection click (indicates valvular AS and excludes supra and subvalvular AS; disappears on calcification of aortic valve)
- Carotid thrill (shudder) is felt
- A rough, ejection systolic murmur loudest in the aortic area radiating to the carotids and the apex
- AS murmur – low pitched, rough, rasping in character.

Severity

1. *According to S_2*

Mild stenosis	A_2 followed by P_2
Moderate stenosis	A_2 is delayed giving rise to single S_2
Severe stenosis	Reverse splitting of S_2 (P_2-A_2).
2. *According to valve area*
 - Normal aortic valve area is $3\text{ cm}^2-4\text{ cm}^2$
 - In severe aortic stenosis, valve area is $< 0.75\text{ cm}^2/\text{m}^2$ body surface area.
 - In critical aortic stenosis, valve area is $< 0.5\text{ cm}^2/\text{m}^2$ body surface area.
3. *Long murmur and late peaking of murmur indicate severe AS.*
4. *According to the gradient across aortic valve*

Normal gradient	0 mm Hg
Stenotic gradient	
Mild AS	< 25 mm Hg
Moderate AS	$25-40$ mm Hg
Severe AS	> 40 mm Hg
5. *Presence of S_4 and absent A_2 indicate severe AS.*
6. *Presence of S_3 in AS means severe systolic dysfunction and elevated filling pressure.*

Silent AS

Severe AS with CCF (low cardiac output).

In this situation, AS murmur is not heard. But murmur reappears on treating failure.

When MS is associated with AS, usually MS masks the signs of AS.



Complications

Left ventricular failure
 Arrhythmias including sudden death
 Complete heart block
 Infective endocarditis

Gastrointestinal bleed due to angiodysplasia of colon and is corrected by AV replacement.



Investigations

ECG

- LVH with strain pattern
- LBBB, complete heart block if calcification of valve extends into the conducting system.

Chest X-ray

Post-stenotic dilatation of ascending aorta in valvular AS; Calcification of aortic valve on fluoroscopy or lateral view.

Echocardiogram

Calcified valve, hypertrophied LV, Doppler estimate of gradient.

Cardiac Catheterisation

Systolic gradient between LV and aorta; post-stenotic dilatation of aorta; regurgitation of aortic valve may be present.

Indication:

- Multivalvular lesions
- Supravalvular or subvalvular lesion
- Noncalcific valvular lesion in young.

Coronary Angiogram

To rule out coronary artery disease only in patients with AS developing symptoms of angina.

It is indicated in patients > 45 years with severe AS.

Prognosis

Patients developing angina have a life expectancy of about 4 years. Patients developing syncope have a life expectancy of about 3 years. Patients developing LVF have a life expectancy of about 2 years.



Management

Medical

Treatment of cardiac failure
 Rheumatic fever prophylaxis
 Infective endocarditis prophylaxis.

Use diuretics with caution to avoid volume depletion in the management of cardiac failure. Similarly digitalis and vasodilators – ACE inhibitors should be avoided in

moderate or severe aortic stenosis. Nitroglycerine is useful for the relief of angina. Statins are useful in the management of degenerative calcific aortic stenosis.

Surgical

- Patients are prone for Stokes-Adams attacks and sudden death and so valve replacement is normally needed.
- *Valve replacement* when systolic gradient across the valve is > 40 mm Hg and when there is progressive LV dysfunction.
- If patient is unfit for surgery, *percutaneous, trans-catheter aortic valve replacement* can be tried. It is also useful in children and young adults with congenital AS, and also as a bridge to surgery in patients with severe LV dysfunction.
- *Simple commissural incision* under direct vision is done in children and adolescents with non-calcific congenital AS; it is indicated in symptomatic patients and also for asymptomatic patients with pressure gradient above 50 mm Hg, i.e. aortic valve orifice is < 0.75 cm².

Aortic Regurgitation (AR) (Fig. 3.127)

- Pure AR is more common in males.
- Mitral valve disorder with AR is more common in females.

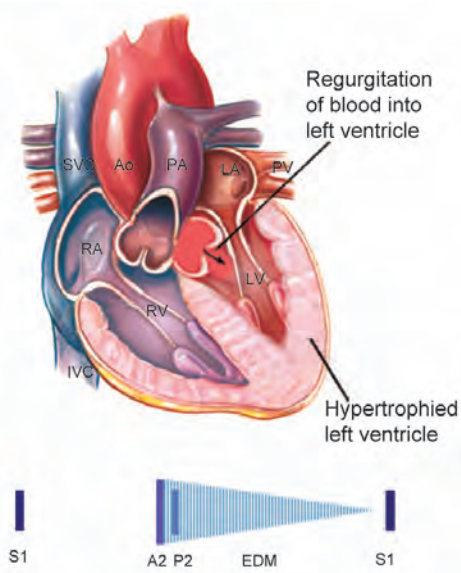

Fig. 3.127: Aortic regurgitation



Fig. 3.128: Congenital bicuspid aortic valve



Causes

Aortic Valve Involvement

Rheumatic heart disease
 Infective endocarditis
 Congenital bicuspid aortic valve (Fig. 3.128)
 Congenital fenestration of AV
 AV prolapse associated with VSD
 Secondary AR in membranous sub-aortic stenosis.

Aortic Wall Involvement

Syphilis
 Rheumatoid arthritis
 Ankylosing spondylitis
 Marfan's syndrome
 Ehlers-Danlos syndrome
 Takayasu's arteritis
 Aortic dissection
 Systemic hypertension
 Osteogenesis imperfecta
 Idiopathic dilatation of aorta
 Annulo-aortic ectasia.

Symptoms

Dyspnoea, palpitation, angina (in severe AR).

Signs of Wide Pulse Pressure

1. *Light house sign* (alternate flushing and blanching of forehead).



2. *Landolfi's sign* (Change in pupillary size in accordance with cardiac cycle and not related to light).
3. Retinal artery pulsations (*Becker's sign*).
4. *de Musset's sign* (head bobbing with each heart beat). It is due to ballistic effect of severe AR.
5. *Muller's sign*—Systolic pulsations of uvula.
6. *Quincke's sign* (capillary pulsations) can be detected by pressing a glass slide on patients lip or nail bed.
7. Dancing carotids (*Corrigan's sign*).
8. Locomotor brachii.
9. Collapsing or water-hammer pulse (\uparrow systolic pressure and \downarrow diastolic pressure); usually pulse pressure is more than the diastolic pressure.
10. Bisferiens pulse.
11. Pistol shot femorals (*Traube's sign*) arteries
Pistol shot sound over the femoral vein is heard in severe TR.
12. *Duroziez's sign*—systolic murmur heard over femoral artery when it is compressed proximally and a diastolic murmur when it is compressed distally using the 'bell' of the stethoscope.
Duroziez's murmur—diastolic murmur heard with the diaphragm of the stethoscope when distal pressure is applied.
13. *Hill's sign*—popliteal cuff systolic pressure exceeds brachial cuff pressure by > 20 mm Hg.

Mild AR	20–40 mm Hg
Moderate AR	40–60 mm Hg
Severe AR	> 60 mm Hg.
14. *Rosenbach's sign*—pulsations of liver.
15. *Gerhardt's sign*—pulsations over enlarged spleen.

Other Signs

- Apical impulse is displaced downwards and outwards and hyperdynamic in nature.
- Soft S_1 (only in acute AR)
- S_3 may be heard
A high frequency decrescendo early diastolic murmur immediately after A_2 , best heard in left 3rd or 4th spaces with the diaphragm of the stethoscope with the patient leaning forwards, in expiration.
- Flow ESM across aortic valve heard at heart base, conducted to carotids.
- Flow MDM across mitral valve (*Austin-Flint murmur*). In MS, there is loud S_1 and there is opening snap.
- AR murmur in aortic area – Aortic root dilatation
- AR murmur in 2nd aortic area – Valvular lesion
- AR murmur is increased by hand grip

Severity

The presence of the following indicate severe AR:

- a. Duration of murmur ($> 2/3$ of diastole) is directly proportional to the severity. In moderate to severe AR, murmur becomes holodiastolic and may have a rough quality.
- b. Bisferiens pulse
- c. Hill's sign > 60 mm Hg.
- d. Apical impulse (down and out)
- e. Austin-Flint murmur
- f. Marked peripheral signs.
They are absent in depressed myocardial function.

In the presence of heart failure, due to peripheral vaso-constriction, there may be a rise in arterial diastolic pressure. This may cause an erroneous judgement as to the severity of AR. Proper assessment can be done, only after correcting the failure.

ECG

LV enlargement (volume overload) – 'q'-waves in V_5 , V_6 .

Chest X-ray

- Gross cardiomegaly (Cor Bovinum)
- In syphilitic AR, there may be calcification of ascending aorta
- In bicuspid aortic valve or rheumatic AR, there may be calcification of the aortic valve.

Echocardiogram

Dilated LV, hyperdynamic ventricle, fluttering anterior mitral leaflet; Doppler detects reflux (Fig. 3.129).

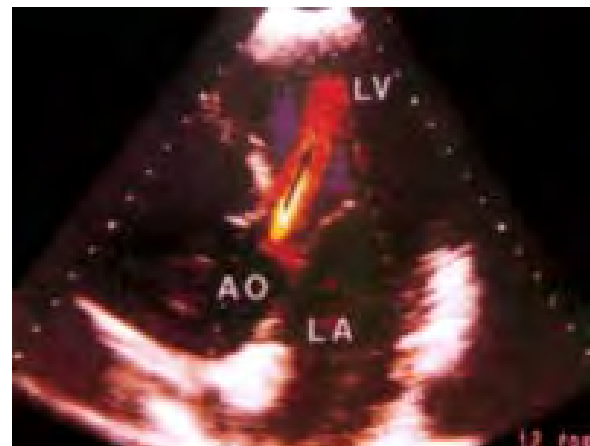

Fig. 3.129: Colour Doppler flow imaging aortic regurgitation



Cardiac Catheterisation

Dilated LV, aortic regurgitation
Dilated aortic root.



Management

Medical

Antifailure measures
Rheumatic fever prophylaxis
Infective endocarditis prophylaxis.

Vasodilators like ACE inhibitors are very useful in the management of AR.

Acute AR

1. Diuretics
 2. IV nitroprusside
 3. Surgery
- β -blockers and intraaortic balloon counterpulsation are contraindicated.

Chronic AR

- Other vasodilators like hydralazine, dihydropyridine calcium channel blockers are useful.
- Penicillin prophylaxis is essential in syphilitic aortitis.
- β -blockers are useful in aortic root dilatation with or without AR.
- The goal is to reduce systolic BP to 140 mm of Hg.

Surgical

Early left ventricular systolic dysfunction even in the absence of symptoms is an indication for surgery.

- a. Valve replacement
- b. Surgical repair in case of perforation of a leaflet by infective endocarditis or in case of a torn leaflet.
- c. Narrowing of annulus or excising a portion of the aortic root without replacing the valve.
- d. Echocardiogram must be performed every year and aortic valve replacement is indicated in patients with end-systolic dimension > 55 mm or end-systolic volume > 55 ml/m² or ejection fraction < 55% (Rule of 55) or end-diastolic dimension > 75 mm.



Causes of Acute AR

Aortic dissection
Trauma
Infective endocarditis
Collagen vascular disorders
Prosthetic valve dysfunction.

Austin-Flint Murmur

Due to absence of LV enlargement, in acute AR, an early increase in LV pressure more than that of LA pressure causes a pre-mature closure of mitral valve resulting in absent pre-systolic murmur.

Differentiating Features between Acute and Chronic AR

Features	Acute AR	Chronic AR
Onset	Early, sudden	Late, insidious
Pulse pressure	Near normal	Wide
Systolic pressure	Normal or decreased	Increased
Diastolic pressure	Normal or decreased	Markedly decreased
LV impulse	May be normal and not hyperdynamic	Hyperdynamic
Auscultation		
a. S ₁	Soft or absent	Normal
b. P ₂	Normal or increased	Normal
c. S ₃	Common	Uncommon
d. AR murmur	Short, medium pitched	Long, high pitched
e. Aortic systolic murmur	Grade 3 or less	Grade 3 or more
f. Austin-Flint murmur	No pre-systolic murmur	Pre-systolic murmur may be heard
Peripheral arterial signs	Absent	Present
ECG	Normal LV	LV enlargement
Chest X-ray	Normal to moderately increased LV; pulmonary venous pattern redistributed to upper lobes	LV markedly increased; aortic root prominent; pulmonary venous pattern normal



Causes of Combined AS and AR

Congenital-bicuspid aortic valve
Rheumatic heart disease (usually associated with mitral valve involvement)
Systemic lupus erythematosus
Subvalvular AS when complicated by infective endocarditis.

Tricuspid Stenosis (TS)

This is an uncommon valvular lesion usually associated with mitral valve disease. TS is more common in females.



Causes

Rheumatic heart disease



Differentiating Features between Rheumatic AR and Syphilitic AR

Features	Rheumatic AR	Syphilitic AR
History	Rheumatic fever	Syphilis
Angina	Less common	Common
A ₂	Normal or soft	Loud, tambour like
Diastolic murmur-site	Third left space (to the left of sternum)	Second right space (to the right of sternum)
Peripheral signs of AR	Not well-marked	Very well-marked
Other valvular lesions	Common	Never present
VDRL	Negative	Positive
X-ray	Calcification of the valve may be seen when there is associated AS; No irregularity of aortic shadow	Calcification confined to ascending aorta; Irregularity of aortic shadow may be seen

Difference between Austin-Flint Murmur and MS

Features	MS	Austin-Flint Murmur
Opening snap	Present	Absent
Loud S ₁	Present	Absent
S ₃	Absent	Present
LVH	Absent	Present
RVH	Present	Absent
Change in murmur with amylnitrite	Intensity of murmur does not decrease	Intensity of murmur decreases
AF	May be present	Usually absent

Congenital TS
Carcinoid syndrome.

When to entertain the diagnosis of TS

- When pulmonary congestion disappears in patients with mitral stenosis
- When MS findings are masked
- When there is no improvement after MS surgery.

Symptoms

Dyspnoea (relatively less for the degree of hepatomegaly, ascites and oedema), fatigue.

Signs

- Giant 'a'-waves in JVP
- Prominent presystolic pulsations of the liver (represents an equivalent of 'a'-wave)
- No palpable P₂ or right ventricular enlargement
- Occasionally OS of tricuspid valve may be heard

- A diastolic murmur over tricuspid area which increases during inspiration (Carvalho's sign) and reduces during expiration or Valsalva manoeuvre
- Signs of right heart failure—ascites, oedema, etc.

ECG

Absence of evidence of RVH in patients with right sided failure.

Chest X-ray

In combined MS and TS, there is prominence of right atrium and SVC without much enlargement of pulmonary artery.

Echocardiogram

Fused, thickened tricuspid valve; Dilated RA, Doppler features of TS.

Treatment

Antifailure measures.

In mild TS, surgery is not ordinarily indicated. In moderate to severe TS, definitive surgical treatment is indicated (i.e. mean diastolic pressure gradients exceeding 4 to 5 mm Hg and tricuspid orifice < 1.5 to 2 cm²).

TS is mostly accompanied by TR and in such cases, valve replacement may be indicated.

The incidence of thromboembolic episode is more common after mechanical valve replacement.

In the presence of TS, TR is mostly organic.

In the absence of TS, TR is mostly functional.

Tricuspid Regurgitation (TR)

Causes

Primary

Rheumatic
Infective endocarditis (in IV Drug Addicts)
Ebstein's anomaly
Carcinoid syndrome
Trauma.

Secondary

Right ventricular dilatation (functional TR as seen in MS or MR with PHT, Eisenmenger's syndrome, PS and primary pulmonary hypertension).



Right ventricular infarction.
Dilated cardiomyopathy
RV apical pacing.

Symptoms and Signs

- Weakness, fatigue
- Throbbing pulsations in the neck (raised JVP)
- Cyanosis (right to left shunt through patent foramen ovale)
- Jaundice
- Massive oedema
- Irregularly irregular pulse (due to AF)
- Jugular venous distension (large, systolic 'cv' wave or 's' wave)
- A venous systolic thrill and murmur in the neck may be present
- RV type of apical impulse which is hyperdynamic and thrusting
- S₃ originating from RV
- P₂ loud when TR is associated with PHT
- A high pitched PSM loudest in 4th intercostal space in the parasternal region augmented during inspiration (*Carvallo's sign)
- Systolic hepatic pulsation
- Positive hepatojugular reflux
- Ascites
- Painful congestive hepatomegaly.

Severity

Murmur is short in mild TR and long in severe TR.

ECG

Non-specific; incomplete RBBB; 'Q'-waves in V₁ and features of AF.

Chest X-ray

Marked cardiomegaly (prominent RA and RV).

Echocardiogram

RV dilatation; Tricuspid valve may be structurally abnormal.



Management

Isolated TR without PHT (as a consequence of trauma or infective endocarditis) is usually well-tolerated.

Effective correction of mitral valve disease and antifailure measures result in marked improvement.

Rarely, tricuspid annuloplasty or valve replacement is done.

Pulmonary Stenosis (PS)



Causes

- Congenital
 - Isolated
 - Associated with VSD (Fallot's tetralogy)
- Carcinoid syndrome
- Rheumatic heart disease.

PS is usually of congenital origin; Rheumatic inflammation of the pulmonic valve is very uncommon and is usually associated with involvement of other valves and rarely leads to serious deformity.

Congenital PS is dealt in detail under congenital heart disease.

Pulmonary Regurgitation (PR)



Causes

Pulmonary dilatation	Idiopathic
	Marfan's syndrome
Pulmonary hypertension	Primary
	Secondary
	a. Eisenmenger's syndrome
	b. Mitral stenosis
Infective endocarditis	IV Drug addicts
Trauma	

Signs

Graham-Steell murmur—a high pitched decrescendo diastolic blowing murmur along left sternal border resembling AR murmur.

Trivial PR is a frequent echocardiographic finding in normal individuals (not of clinical significance).

Difference between AR and PR

Features	AR	PR
Signs of wide pulse pressure	Present	Absent
Apex beat	Hyperdynamic	Normal
Relation of murmur to respiration	None	Increases on inspiration
Ventricular enlargement	LVH	RVH

* Auscultatory augmentation of a tricuspid murmur during inspiration is called as Carvallo's sign.



Infective Endocarditis (IE)

It is the colonisation of the heart valves with micro-biologic organisms, leading to the formation of friable, infected vegetations and frequently valve injury.

Types

1. *Acute infective endocarditis*: Caused by highly virulent organisms mainly *S. aureus* (20–30%), seeding a previously normal valve.
2. *Subacute infective endocarditis*: Caused by organisms of moderate or low virulence mainly Streptococci (60–70%), seeding an abnormal or previously injured valve.
3. *Endocarditis occurring in IV drug abusers*: Caused predominantly by organisms found on the skin (*S. aureus*, *Candida*) and affecting the valves on the right side of the heart.
4. *Prosthetic valve endocarditis*: This may be early (symptoms appearing within 60 days of valve insertion), due to intraoperative infection of the valve or insertion of an infected valve or late (symptoms appearing after 60 days of valve insertion), due to late bacteraemia or earlier infection with micro-organisms having a long incubation period.

Prosthetic aortic valve is more prone for infective endocarditis than the mitral valve.

Right sided IE has a more favourable prognosis than the left sided IE. However, when right sided IE vegetation size exceeds 2 cm, the mortality increases.

Predisposing Factors to Development of Infective Endocarditis

1. Congenital cardiac anomalies (shunts or stenosis with jet streams)
2. Rheumatic heart disease
3. Mitral valve prolapse
4. Degenerative calcific stenosis
5. Bicuspid aortic valve
6. Prosthetic valves
7. Indwelling catheters.

Clinical Manifestations

Symptoms

- a. Fever (low grade in subacute infective endocarditis and high grade in acute infective endocarditis).
- b. Malaise
- c. Fatigue
- d. Anorexia.

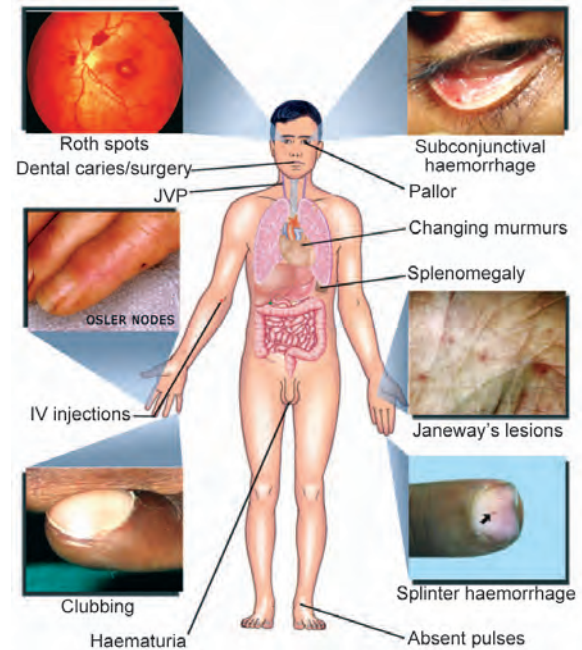

Fig. 3.130: Infective endocarditis

Signs (Fig. 3.130)

- a. Clubbing (seen after 6 weeks in 10–20% of patients)
- b. Splenomegaly (seen after 6 weeks in 30% of patients)
- c. Pallor (anaemia)
- d. Heart murmurs (new, esp. regurgitant murmurs, or changing murmurs)
- e. Petechiae (seen after 6 weeks over conjunctiva, palate, buccal mucosa and skin above clavicle)
- f. Splinter subungual haemorrhages
- g. Osler nodes (small tender nodules, 1–10 mm diameter, on the finger or toe pads as a result of septic emboli and immune complex deposition)
- h. Janeway lesions (1–4 mm non-tender erythematous macules over palms and soles due to septic emboli)
- i. Roth's spots (oval retinal haemorrhages with a pale centre)
- j. Arthralgia or arthritis.

Clinical Consequences of Infective Endocarditis (Figs 3.131 and 3.132)

1. Injury to valves or myocardium (abscess formation or perforation).
2. Embolism (brain, spleen, kidneys and pulmonary embolism).
3. Mycotic aneurysm.
4. Cerebral abscess.
5. Diffuse or focal glomerulonephritis or nephrotic syndrome.

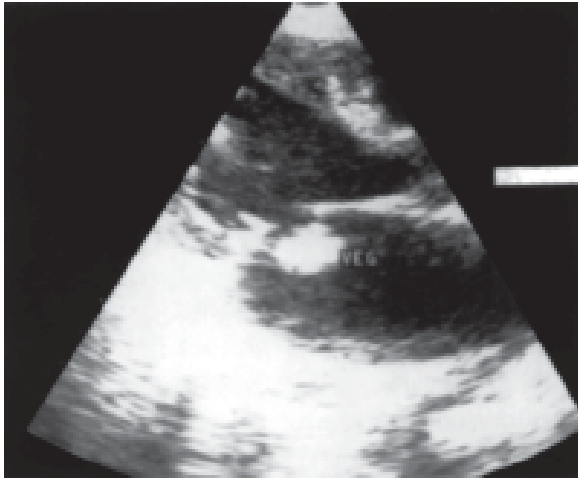

Fig. 3.131: Mitral valve vegetation

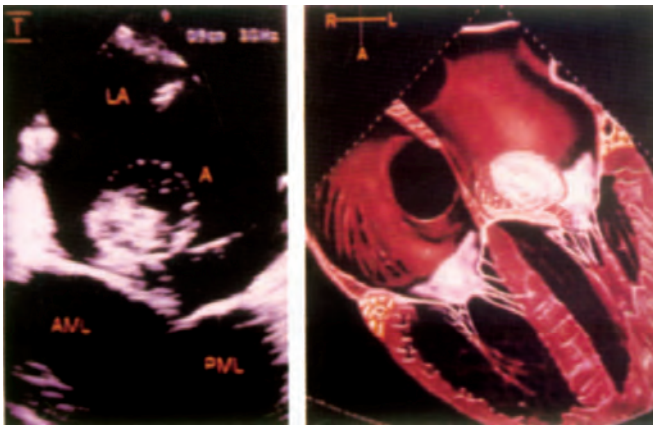

Fig. 3.132: Transoesophageal echo—large mitral valvular abscess

Lab Diagnosis

Blood Culture

- At least 3 blood culture samples and maximum of six blood culture samples to be taken.
- Each sample to be collected from different venipuncture sites and after 30 minutes to 1 hour gap (to demonstrate continuous bacteraemia).
- At least 10 ml of blood to be obtained for culture and diluted 10 fold in culture medium (100 ml of culture medium).
- Culture to be done for both aerobic and anaerobic organisms.
- Yield of positive culture increased by observing them over 3 weeks and making periodic subcultures.
- Presumptive antibiotics to be started immediately after obtaining culture samples.

Negative Blood Culture in Infective Endocarditis

- Infection with fastidious organisms (*H. parainfluenzae*, *Brucella*)
- Anaerobic infection
- Candida, Aspergillus, Histoplasma, *Coxiella burnetii*, *Chlamydia psittaci endocarditis*
- Inadequate quantity of blood sample for culture or inadequate amount of culture media
- Prior antibiotic therapy
- Right sided endocarditis.

2D Echo

- The smallest size of vegetation that can be picked up by echo is 2 mm.
- Transoesophageal echocardiography is more sensitive in detecting vegetations in the aortic valve (90%) and mitral valve (100%) than transthoracic echocardiography.

Duke's Criteria

Major Criteria

- Positive blood culture
(Typical organisms in two separate cultures or persistently positive blood cultures)
- Involvement of endocardium
(Echo based evidence—vegetations, abscess, perivalvular dehiscence or new valvular regurgitation)

Minor Criteria

- Predisposition (Cardiac lesion, IV drug abuse)
- Fever $> 38^{\circ}\text{C}$
- Vascular or immunological signs
- Positive blood culture – that does not meet major criteria
- Positive echo- that does not meet major criteria

Diagnosis: Diagnosis confirmed by 2 major/1 major + 3 minor/all 5 minor criteria.

Indications for Endocarditis Prophylaxis

- Dental procedures
- Respiratory tract procedures
Rigid bronchoscopy (Not for flexible)
- GIT – Procedures
 - Variceal sclerotherapy
 - Stricture dilatation
 - ERCP, Biliary tract surgery
 - Surgery involving mucosa
- Genito-urinary procedures
 - Cystoscopy
 - Urethral dilatation
 - Prostate/Urethral surgery



5. Cardiac conditions

High Risk

- i. Prosthetic valves
- ii. Prior IE
- iii. Complex congenital cyanotic heart disease
- iv. PDA/COA
- v. Created systemic pulmonary shunts

Moderate Risk

VSD, Bicuspid aortic valve, Acquired - AS, AR, MR, MVPS (MR/Thickened valves), Congenital cardiac malformations

Prophylaxis not needed:

- i. Isolated secundum ASD
- ii. Surgically corrected ASD, VSD, PDA (more than 6 months after repair)
- iii. MVPS without complications
- iv. Prior CABG
- v. Implanted defibrillators/Pacemakers
- vi. Physiological/Functional murmurs
- vii. Acute rheumatic fever without valve dysfunction.

Treatment

- Inj. Benzyl penicillin 20–40 lakh units IV 4 hourly for 4 weeks.
- Parenteral aminoglycosides (SM, GM, Amikacin) given in appropriate divided doses for the first 2 weeks.
- Appropriate antibiotic changes may be made on receiving the results of blood culture.

Prophylaxis in IE

Capsule Amoxycillin 3 gm orally, 1 hour before the procedure and 1.5 gm orally 6 hours after the first dose.

Indications for Surgical Management

- a. Failure of medical treatment as indicated by persistent positive blood culture or refractory failure
- b. Myocardial or valve ring abscess
- c. Aortic valve endocarditis developing heart block
- d. Prosthetic valve endocarditis
- e. Presence of large vegetation with possible embolism
- f. Fungal endocarditis.

Non-infective Endocarditis

Non-bacterial thrombotic endocarditis (Marantic endocarditis): Non-bacterial thrombotic vegetations seen in malignancy or wasting disorders which are prone for bacterial seedling.

Endocarditis associated with SLE (Libman-Sachs endocarditis): The vegetations are 3–4 mm in size, composed of degenerating valve tissue; functional disability is minimal; ventricular surface of the mitral valve is commonly involved; aortic valve involvement is rare; entire valve apparatus can be involved.

Cardiac Failure

Cardiac failure occurs when the heart fails to maintain sufficient circulation to provide adequate tissue oxygenation in the presence of normal filling pressures.

Preload

Preload is the left ventricular end-diastolic pressure and it depends on left ventricular compliance and venous return.

Afterload

Afterload is the left ventricular systolic wall tension that develops during ventricular systole and is determined by aortic valve resistance, the peripheral vascular resistance and the elasticity of major blood vessels.

Classification of Cardiac Failure

High Output and Low Output Failure

- a. *High output failure:* The normal heart fails to maintain a normal or increased output, in the face of grossly elevated requirements, as in anaemia, hyperthyroidism, Paget's disease, A-V malformation, pregnancy. Features of RVF predominate at first, but later LVF becomes evident. It is difficult to determine if the patient with high output state has developed cardiac failure. The only clue to the development of CCF in these patients may be the presence of shortened circulatory time.
- b. *Low output failure:* The heart fails to generate adequate output, or can only do so with high filling pressures, as in
 - i. Intrinsic heart muscle disease (Cardiomyopathy, IHD, Myocarditis, Chagas' disease).
 - ii. Chronic excessive afterload (Aortic stenosis, Hypertension).
 - iii. Chronic excessive preload (Mitral regurgitation).
 - iv. Negative inotropic drugs (Anti-arrhythmic agents).
 - v. Restricted filling (Constrictive pericarditis or tamponade, restrictive cardiomyopathy).
 - vi. Extreme bradycardia (beta-blockers, complete heart block).

Right and Left Sided Heart Failure

- Right sided heart failure:* This causes peripheral oedema, abdominal discomfort (congestive hepatomegaly) raised JVP and hypotension. There is no evidence of pulmonary oedema.
- Left sided heart failure:* Most prominent sign is the presence of pulmonary oedema. Other signs are tachypnoea, tachycardia, third heart sound, pulsus alternans, cardiomegaly.
- Congestive cardiac failure:* Patient has features of both right and left sided heart failure.



Investigations

Chest X-ray

- Prominent upper lobe veins (PCWP = 15 mm Hg).
- Kerley B lines (engorged peripheral lymphatics seen in the lower lobe (PCWP = 20 mm Hg).
- Fluid in the fissures or interlobar effusion, known as 'phantom tumour' as it disappears with the treatment of left sided failure.
- Increase in broncho-vascular markings ('bat's wing' or 'inverted moustache' signs)—features of pulmonary oedema (PCWP: 25 mm Hg).
- Pleural effusion may be bilateral and symmetrical, but if unilateral, is usually right sided.
- Cardiomegaly.

Forward and Backward Heart Failure

- Forward heart failure:* This results from an inadequate discharge of blood into the arterial system leading to poor tissue perfusion; Poor renal perfusion results in excessive proximal tubular Na^+ reabsorption through activation of the renin-angiotensin-aldosterone system.
- Backward heart failure:* This results from the failure of one or the other ventricle to fill normally and discharge its contents, causing an elevated atrial and venous system pressure behind the failing ventricle.

Systolic and Diastolic Failure (Fig. 3.133)

- Systolic failure* occurs when there is inadequate cardiac output (IHD) and is usually associated with cardiomegaly. This is managed by using predominantly inotropic agents, e.g. Digoxin, Dopamine and Dobutamine.
- Diastolic failure* occurs when there is increased resistance to ventricular inflow and reduced ventricular diastolic capacity (constrictive pericarditis, restrictive cardiomyopathy, IHD) and is usually associated with

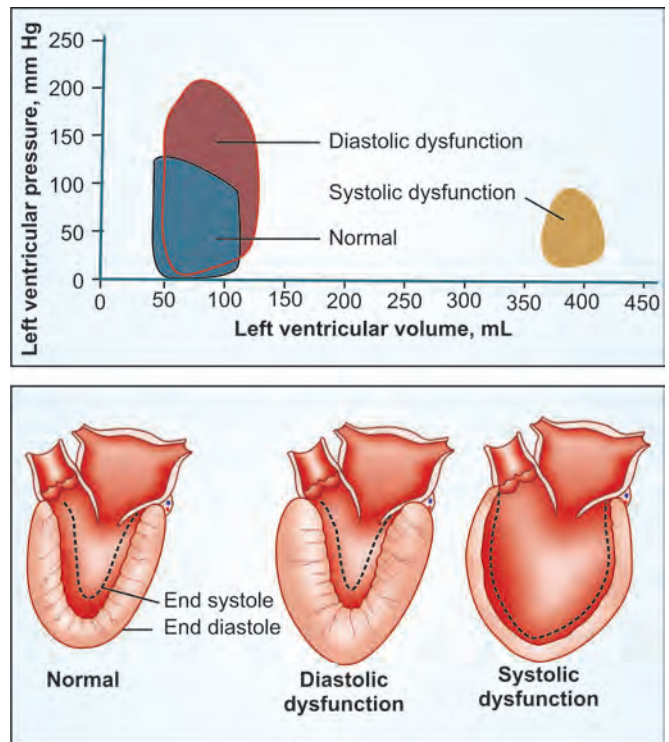

Fig. 3.133: Types of heart failure

cardiomegaly. This is managed by predominantly using vasodilator therapy, e.g. (ACE inhibitor and Calcium channel blocker).

Framingham Criteria for Diagnosis of CCF

Major Criteria:

- Paroxysmal nocturnal dyspnoea
- Neck vein distension
- Crackles – lung fields
- Cardiomegaly
- Acute pulmonary oedema
- Third heart sound – gallop
- Increased venous pressure ($>16 \text{ cm H}_2\text{O}$)
- Positive hepato-jugular reflex

Minor Criteria:

- Extremity oedema
- Nocturnal cough
- Dyspnoea on exertion
- Hepatomegaly
- Pleural effusion
- Tachycardia ($>120 \text{ bpm}$)
- Decreased vital capacity by 1/3

Major/Minor Criteria:

5 days treatment causing weight loss $> 4.5 \text{ kg}$.

For diagnosis: 1 Major + 2 Minor



Characteristics of Systolic and Diastolic Heart Failure

Characteristics	Diastolic heart failure	Systolic heart failure
Age	Elderly	Any age group
Sex	More often female	More often male
LV ejection fraction	Often preserved - > 40%	Decreased - < 40%
Cavity size of LV	Normal or concentric LVH	Usually dilated
Chest X-ray	Congestion with or without cardiomegaly	Cardiomegaly with congestion
Gallop rhythm	Fourth heart sound	Third heart sound
Associated disorders		
• Obesity	+++	+
• Hypertension	+++	++
• Diabetes mellitus	+++	++
• Previous MI	+	+++
• COPD	++	0
• Long-term dialysis	++	0
• Sleep apnoea	++	++
• Atrial fibrillation	+	+



Causes of Refractory Cardiac Failure

1. Silent myocardial infarction
2. Pulmonary emboli
3. Thyrotoxicosis
4. Left ventricular aneurysm
5. Silent valvular stenosis
6. Beri-beri
7. Anaemia
8. Myocarditis
9. Infection
10. Pregnancy
11. Arrhythmias
12. Infective endocarditis
13. Cardiac tamponade, constrictive pericarditis
14. Iatrogenic-electrolyte imbalance due to diuretic excess, digoxin induced arrhythmias
15. Massive hydrothorax.
16. Poor drug compliance.
17. Other unrelated diseases like viral hepatitis, cirrhosis
18. Inadequate salt and water restriction.
19. SA or AV nodal dysfunction.
20. Suboptimal dose of cardiac glycoside.

B-Type Natriuretic Peptide (BNP)

This hormone is synthesised by the right and left ventricular myocytes and released in response to

stretch, volume overload and elevated filling pressures. The serum level of this hormone is very specific and sensitive to identify or to exclude heart failure. BNP is extremely useful in diagnosis, prognosis and monitoring therapy. Serum levels of BNP are elevated in heart failure and as well as in asymptomatic LV dysfunction. BNP level <100 pg/ml excludes heart failure.

Uric acid, CRP, troponin I and T, TNF receptors are other bio-markers of heart failure.

Treatment of Cardiac Failure

The general principles of management are:

1. Removal of precipitating causes, i.e. anaemia, arrhythmias, infection, pregnancy, thyroid disorders, smoking, alcohol; drugs like—beta blockers, calcium channel blockers, NSAIDs, infective endocarditis, hypertension, myocardial infarction, pulmonary embolism, dietary and medical noncompliance
2. Correction of underlying causes, i.e. congenital heart disease, rheumatic heart disease, IHD
3. Control of fluid and sodium retention
4. Enhancement of myocardial contractility
5. Reduction of pulmonary and systemic venous congestion
6. Minimisation of cardiac workload.



Treatment of Acute Heart Failure

Haemodynamic profile in patients with acute heart failure:

Profile A: (warm and dry)

- Normal LV filling pressure
- Normal cardiac output
- Normal systemic vascular resistance
- Patient is warm and dry

Profile B: (warm and wet)

- Increased LV filling pressure
- Normal cardiac output
- Normal systemic vascular resistance
- Patient is warm and wet
- Use diuretics and vasodilator

Profile C: (cold and wet)

- Increased LV filling pressure
- Decreased cardiac output
- Increased systemic vascular resistance
- Patient is cold and wet
- Use inotropic agents with vasodilator properties

Profile L: (cold and dry)

- Normal LV filling pressure
- Decreased cardiac output

- Increased systemic vascular resistance
- Patient is cold and dry
- Cautious trial of fluid repletion
(If pulmonary capillary wedge pressure < 12 mm of Hg as evaluated by right heart catheterisation)

The ultimate goal is to treat B, C, and L to reach normal haemodynamic profile (Profile A).

(Wet – elevated LV filling pressure with signs of fluid retention as evidenced by elevated neck veins, pulmonary crackles and peripheral oedema. Dry – no congestion and no oedema. Warm indicates good tissue perfusion. Cold indicates poor tissue perfusion.)

Drugs and dosage—Management of Acute Heart Failure

	<i>Initiating dose</i>	<i>Maximal dose</i>
Vasodilators:		
Nitroglycerin	20 mcg/minute	40-400 mcg/minute
Nitroprusside	10 mcg/minute	30-300 mcg/minute
Nesiritide Bolus	12 mcg/kg	0.1-0.2 mcg/kg/min
Inotropes:		
Dobutamine	1-2 mcg/kg/min	2-10 mcg/kg/min
Milrinone Bolus	50 mcg/kg	0.1-0.75 mcg/kg/min
Dopamine	1-2 mcg/kg/min	2-4 mcg/kg/min
Levosimendon Bolus	12 mcg/kg	0.1-0.2 mcg/kg/min
Vasoconstrictors:		
Dopamine	5 mcg/kg/min	5-15 mcg/kg/min
Epinephrine	0.5 mcg/kg/min	50 mcg/kg/min
Phenylephrine	0.3 mcg/kg/min	3 mcg/kg/min
Vasopressin	0.05 units/min	0.1-0.4 units/min

Cardiogenic Pulmonary Oedema (CPE)



Clinical Features

- Dyspnoea, anxiety, restlessness
- Pink frothy sputum
- Pulmonary congestion – wheezing and crackles

- Decreased peripheral perfusion
- Use of accessory respiratory muscles
- Chest X-ray – Cardiomegaly, Kerley B lines, perihilar vascular engorgement, pulmonary oedema, pleural effusions.



Management

1. Sitting position with back/cardiac rest improves pulmonary function
2. Oxygen to raise the oxygen tension to > 60 mm of Hg
3. If oxygenation is inadequate – mechanical ventilation
4. Strict bed rest, pain control and anxiety relief
5. Treatment of precipitating disorders – HTN, MI, IHD, volume overload, arrhythmias
6. Morphine sulphate 5 mg IV (anxiety relief, dilatation of pulmonary and systemic veins) Repeat every 15 minutes if need be
7. Frusemide 40-80 mg IV and can be repeated to a maximum dose of 200 mg
8. Nitroglycerin – a powerful venodilator as IV infusion
9. Nitroprusside – if CPE is due to valvular regurgitation or HTN
10. Inotropic agents like dopamine, dobutamine, milrinone in case of hypotension or shock
11. Recombinant BNP (nesiritide) IV bolus followed by IV infusion – reduces intra-cardiac filling pressures by producing vasodilatation.

A. Non-pharmacologic Measures

Physical Rest

In acute phase, absolute bed-rest is advised. Early ambulation is advocated to avoid deep vein thrombosis.

American Heart Association Guidelines—Treatment of Chronic Heart Failure

<i>Stage</i>	<i>Nature of cardiac lesion</i>	<i>Treatment</i>
A	No structural heart disease and no symptoms Risk factors for HF – DM, HTN, CAD, Dislipidaemia Familial cardiomyopathy, cardiotoxins	Life style modification, cessation of smoking, diet, exercise and treat the risk factors, Treat HTN with ACE inhibitors
B	Structural heart disease with abnormal LV systolic function – MI, valvular disease but no heart failure symptoms	Life style modification, ACE inhibitors and β- blockers
C	Structural heart disease and heart failure symptoms	Add diuretics and digoxin along with therapy as under stage A and B
D	Refractory heart failure symptoms to maximal medical management	Therapy as listed under stage A, B, C, Mechanical assist devices, IV inotropic infusion, heart transplantation



Prophylactic low dose heparin 5000 U SC/IV BD can be given. Degree of activity can be decided depending on the cardiac status.

Mental Rest

Diazepam 2 to 5 mg twice or thrice daily is given for several days.

Oxygen

It improves oxygen delivery and relieves dyspnoea.

Diet

Small frequent feeds instead of large meals and optimal calories depending on the nutritional status of the patient.

- a. *Sodium restriction*: In severe cases, sodium is restricted to 500 mg/day and subsequently it can be increased to 2 to 3 gm/day with the usage of potent diuretics.
- b. *Water restriction*: 1 to 1.5 litres/day is permitted. Strict fluid restriction is critical when serum sodium is less than 130 mEq/L to prevent arrhythmias and neurologic abnormalities. Water intake may be ad libitum in all but the most severe forms of CCF.

Dialysis and Ultrafiltration

This procedure is indicated in severe HF with renal dysfunction. Therapeutic paracentesis, phlebotomy, rotating tourniquet are other mechanical methods of fluid removal which are useful in the management of refractory failure.

B. Pharmacologic Therapy

1. Diuretics

a. *High potency loop diuretics (Furosemide, Bumetanide, Ethacrynic acid)*: These drugs are most useful in severe heart failure and also in the presence of impaired renal function. Furosemide causes direct venodilatation and reduces preload. It also prevents reabsorption of Na⁺ and Cl⁻ from thick ascending limb of loop of Henle and also from proximal tubule. In severe failure, IV route is preferable since the GIT mucosal congestion may interfere with absorption of orally administered drug.

Dose

Furosemide—40 to 200 mg/day
 Bumetanide—0.5 to 2 mg—maximum 10 mg/day
 Ethacrynic acid—25 to 100 mg/day
 Torsemide – 5 mg IV/10 mg od or bid.

Adverse effects: Hypokalaemia, hypomagnesaemia, hypocalcaemia, hyperglycaemia, hyperuricaemia, ototoxicity,

rash, vasculitis and postural hypotension. Allergic reactions are less with ethacrynic acid than with other loop diuretics and thiazides due to absence of sulfhydryl moiety.

b. *Medium potency thiazide diuretics*: They are useful in mild cardiac failure and in the presence of normal renal function. They act in the distal tubule except metolazone which acts in the proximal and distal tubule. Indapamide is a long acting drug and it has fewer side effects on serum lipids.

Dose:

Chlorothiazides—250 to 500 mg/day
 Hydrochlorothiazide—25 to 100 mg/day
 Chlorthalidone—25 to 100 mg/day
 Metolazone—2.5 to 20 mg/day
 Indapamide—5 to 10 mg/day.

Adverse effects: Hypokalaemia, hyponatraemia, hypomagnesaemia, hyperglycaemia, hypercalcaemia, hyperuricaemia, hyperlipidaemia, alkalosis, pancreatitis, vasculitis, rash.

c. *Low potency potassium sparing diuretics*: They are weak diuretics and they act in the distal tubule and collecting duct. They are contraindicated in the presence of renal failure. Concomitant use of ACE inhibitors, NSAIDs, and presence of DM increase the risk of hyperkalaemia.

Dose

Spironolactone—50 to 200 mg/day
 Triamterene—100 to 200 mg/day
 Amiloride—5 to 10 mg/day.

Adverse effects: Hyperkalaemia, acidosis, and in addition, for spironolactone, gynaecomastia and for triamterene, renal stone and ARF when used with indomethacin.

Eplerenone: It is a selective aldosterone receptor antagonist without the hormonal side effects of spironolactone. It reduces the mortality in heart failure. Aldosterone blockade with eplerenone 25 mg daily with reasonable renal function (serum creatinine < 2 mg and serum potassium < 5 mEq/L) improves heart failure.

2. Vasodilator Therapy

Vasodilators are used to minimise the workload to the heart. Arterial dilators reduce the afterload and the venodilators reduce the preload to the heart. In the presence of volume depletion with hypotension, vasodilators should be used with caution. Vasodilators are not beneficial in HF with outflow tract obstruction and predominant diastolic dysfunction (Restrictive or hypertrophic cardiomyopathy or tamponade).



a. Oral Vasodilators

i. ACE inhibitors: They inhibit the formation of angiotensin II (powerful vasoconstrictor) by blocking angiotensin converting enzyme and this blockade results in reduction of preload and afterload.

Dose

Captopril—6.5 to 25 mg tid
Enalapril—2.5 to 20 mg bid
Lisinopril—2.5 to 10 mg od
Quinapril—10 to 40 mg od
Ramipril—1.25 to 5 mg bid
Fosinopril—5 to 10 mg od can be used bid
Benazepril—5 to 10 mg od can be used bid
Moexipril—5 to 7.5 mg od can be used bid
Trandolapril—1 to 2 mg od
Spirapril—12.5 to 50 mg bid
Cilazapril—2.5 to 5 mg bid
Perindopril—1 to 16 mg bid

Adverse effects: First dose hypotension, (withhold the diuretics for 24 hours before starting ACE inhibitors), dry cough, altered taste, skin rash, hyperkalaemia.

They should not be given when the serum creatinine is more than 3 mg% and in bilateral renal artery stenosis. Agranulocytosis and angioedema are common with captopril because of the presence of sulfhydryl moiety.

ACE inhibitor is very useful in post-infarction failure with reduced ejection fraction below 40%. The reduction in workload allows the ventricle to remodel and reduce the incidence of development of severe cardiac failure.

In ACE inhibitors intolerant patients angiotensin receptor blockers can be used with equal efficacy.

ii. Nitrates: They are predominantly venodilators and are useful in CHD with HF. It relieves venous and pulmonary congestion.

Dose

Isosorbide dinitrate—5 to 20 mg qid
Isosorbide mononitrate—10 to 20 mg tid
Nitroglycerin sustained release—2.5 to 9 mg bid
Transdermal nitroglycerin patches—5 to 15 mg bid.

Headache is the main adverse effect and that might subside with sustained therapy; nitrate tolerance can be prevented by nitrate free interval of at least 10 to 12 hours/day.

iii. Hydralazine: It is an arterial dilator and it reduces the afterload. It is useful in the presence of valvular regurgitant lesions with volume overload. By combining it with nitrate a balanced preload and afterload reduction can be achieved.

Dose: Hydralazine—25 to 100 mg tid.

Adverse effects: Reflex tachycardia (use with caution in IHD), headache, flushing, nausea, vomiting, fluid retention and SLE like syndrome.

iv. Adrenergic blockers

a. Alpha-blockers: They are powerful vasodilators and they reduce the systemic vascular resistance and thereby reduce the afterload. However, the adverse effects like orthostatic hypotension and reflex tachycardia limit their role in the management of heart failure.

b. Beta-blockers: The adverse effects of endogenous catecholamines on the failing heart can be antagonised by beta-blockers. Beta-blockers with ISA activity like pindolol, xamoterol have been tried. A minimum of two months therapy is required to demonstrate improvement in ejection fraction and exercise tolerance. Caution must be exercised in advocating beta-blockers in HF with low ejection fraction. They are useful in hypertrophic cardiomyopathy, dynamic outflow tract obstruction and those with diastolic dysfunction.

The drugs approved for use in cardiac failure are carvedilol, metoprolol and bisoprolol.

v. Calcium channel blockers: Even though they dilate the vascular smooth muscle, their negative inotropic effect limit the usage in HF. Amlodipine and felodipine are preferable than verapamil and diltiazem in the management of heart failure especially in the presence of diastolic dysfunction. They enhance the diastolic relaxation of the ventricle (lusitropic effect). They are absolutely contraindicated in cardiac failure with low ejection fraction (below 40%).

b. Parenteral Vasodilators

They are useful in severe HF. Central haemodynamic monitoring and optimal titration of dosage are essential.

Nitroglycerin: It is a potent venodilator and it relieves systemic and pulmonary venous congestion. This drug is useful in myocardial infarction with HF and also in unstable angina. The dose is 10 to 200 µg/minute. The adverse effects are hypotension and nitrate tolerance.

Sodium nitroprusside: It is a potent arterial dilator and it is very useful in severe hypertensive heart failure and in valvular regurgitant lesions with volume overload.

Dose: 10 to 300 µg/minute

In IHD, it can cause coronary steal. Serum thiocyanate level should be monitored. Levels above 10 mg/dl is manifested as abdominal pain, nausea, seizure, change in the conscious level and metabolic acidosis especially in the presence of renal failure.



Enalaprilat: It can be used in the dose of 1.25 to 5 mg IV six hourly. The indications and adverse effects are similar to oral form of enalapril.

Recombinant BNP-Nesiritide: It can be used as a parenteral vasodilator in a dose of 2µg/kg IV bolus followed by continuous IV infusion of 0.01–0.03 µg/kg/minute. Hypotension is the most common side effect of nesiritide. Avoid using it in cardiogenic shock and in patients with systolic blood pressure < 90 mm of Hg. Episodes of hypotension can be treated with volume expansion vasopressor drugs.

3. Digitalis

Digoxin is the most effective drug in the management of heart failure especially in the presence of:

- Supraventricular tachycardia
- Dilated left ventricle (increased TCD, 3rd heart sound)
- Impaired systolic function (low ejection fraction).

It causes reversible inhibition of sarcolemmal sodium-potassium adenosine triphosphatase. This enhances the myocardial contractility (positive inotropic effect). It slows conduction and prolongs refractory period in AV node, and Purkinje fibres (negative chronotropic effect) and thus reduces the ventricular rate. However, it shortens the refractory period and enhances the excitability in the atria, ventricles and accessory conduction pathways (atrial and ventricular tachyarrhythmias as in toxic doses).

Conduction velocity and effective refractory period are increased in atrium and ventricle. It improves cardiac output and augments ejection fraction. It has little value in hypertrophic cardiomyopathy, myocarditis, constrictive pericarditis, mitral stenosis in sinus rhythm without right ventricular involvement and chronic cor pulmonale. It has no effect in HF with diastolic dysfunction with preserved systolic function and good ejection fraction. The toxic therapeutic ratio is narrow. Hypokalaemia, hypoxaemia, hypomagnesaemia and hypercalcaemia potentiates digitoxicity. Digoxin should be administered with caution in elderly patients with hypothyroidism and in renal failure.

Dose

Digitalising dose: Adult—1 to 1.5 mg. Initiate with 0.5 mg and follow it with 0.25 mg qid. This schedule is implemented in patients who have not received digitalis therapy earlier.

Maintenance dose: Digoxin—0.25 mg od or bid. Maintain serum level of digoxin between 1 to 2 ng/ml.

Drug interactions: Antacids, cholestyramine, kaolin-pectin, bran, neomycin, sulfasalazine and PAS can impair the absorption of digoxin. Digoxin levels are increased by oral erythromycin and tetracycline, quinidine, verapamil, flecainide and amiodarone.

Adverse effects

GIT symptoms: Anorexia, nausea, vomiting, diarrhoea are signs of digitoxicity (if the above symptoms occur only after the initiation of digitalis therapy and not present earlier due to GIT mucosal congestion).

Neurological symptoms: Headache, fatigue, malaise, disorientation, delirium, confusion, convulsions, visual symptoms like scotomas, flickering halos, altered colour vision.

Cardiac toxicities: Bradycardia, multiple VPCs, ventricular bigemini (hallmark of digitoxicity), PAT, VT, VF and any type of cardiac arrhythmias except sinus tachycardia, bundle branch block and Mobitz type II block.

Other manifestations: Gynaecomastia, skin rash and sexual dysfunction.

Management of digitoxicity: Stop digoxin and correct the electrolyte abnormalities, titrate the dose of diuretics. Correct the bradycardia with IV atropine 0.6 mg or temporary pacing. Treat the atrial or ventricular arrhythmias with phenytoin, beta-blockers or lidocaine (never treat with quinidine or verapamil). Cardioversion is usually contraindicated in digitalis induced arrhythmias. However, as a last resort it can be tried in low joules after discontinuing the digitalis, under cover of lidocaine infusion.

Digoxin specific Fab antibody fragment: Fab antibody fragments are considered when other modes of therapy fail. Each 40 mg vial (add 4 ml sterile water) is given in the form of infusion in 100 ml of normal saline in 30 minutes (80 drops/mt). It will neutralise 0.6 mg of digoxin. Dose can be calculated as follows:

$$\text{Number of vials} = \frac{\text{Serum level (ng/ml)} \times \text{Weight in kg}}{100}$$

4. Sympathomimetic Amines

Norepinephrine, epinephrine, isoprenaline, dopamine and dobutamine. These drugs improve cardiac output and improve tissue perfusion at the expense of increased oxygen demand.

Dopamine: It increases renal blood flow, GFR and sodium excretion by stimulating specific dopaminergic receptors

at doses of 1 to 3 $\mu\text{g}/\text{kg}/\text{minute}$. By stimulating β_1 adrenoreceptors at doses of 3 to 5 $\mu\text{g}/\text{kg}/\text{minute}$, it increases the myocardial contractility (inotropic effect) and heart rate. At a higher doses of 5 to 10 $\mu\text{g}/\text{kg}/\text{minute}$ it causes vasoconstriction by stimulating α -adrenoreceptors resulting in elevation of blood pressure. Dopamine should be used primarily to stabilise the hypotensive patient. When large doses of dopamine are required for inotropic effect, nitroprusside or nitroglycerin can be infused simultaneously to counteract the vasoconstrictor action. It is widely used in the management of acute heart failure.

Dobutamine: It is a synthetic catecholamine with marked β_1 and weak β_2 and α receptor activity. In contrast to dopamine, dobutamine is not a renal vasodilator. A low dose infusion of dopamine may be added to dobutamine to obtain a balanced renal vasodilator and inotropic effect. The dose is 2.5 to 10 $\mu\text{g}/\text{kg}/\text{minute}$.

Mode of Action of Inotropic-Vasopressor Agents

Mode of action	Dobutamine	Dopamine		Norepinephrine
		Low dose	High dose	
β -receptor agonism	+	+	+++	++++
β_1 -receptor agonism	++++	+	++	+
β_2 -receptor agonism	++	0	0	0
Dopaminergic	0	+++	++	0
Systemic vascular - resistance	$\downarrow\downarrow$	\downarrow	$\uparrow\uparrow$	$\uparrow\uparrow\uparrow$
Cardiac output	$\downarrow\downarrow\downarrow$	\uparrow	$\uparrow\uparrow$	\uparrow
Increases systemic BP	\uparrow	0	$\uparrow\uparrow\uparrow$	$\uparrow\uparrow\uparrow$
Ventricular filling pressure	$\downarrow\downarrow$	0	0 - $\uparrow\uparrow$	0 - $\uparrow\uparrow$
Chronotropic	0 - $\uparrow\uparrow$	0	0 - $\uparrow\uparrow\uparrow$	0 - \uparrow
Myocardial O_2 demand	\downarrow	0	0 - $\uparrow\uparrow$	0 - $\uparrow\uparrow$

Adverse effects: Precipitation of myocardial ischaemia, ventricular arrhythmias; dopamine can cause severe peripheral vasoconstriction resulting in digital gangrene and local tissue necrosis at the site of extravasation. Inject at the site of extravasation, 5 mg of phentolamine mixed with saline to prevent tissue necrosis.

5. Phosphodiesterase Inhibitors (Amrinone, Milrinone, Enoximone, Pimobendan)

They exert positive inotropic and vasodilator effect through the inhibition of phosphodiesterase III which is a membrane bound enzyme responsible for the breakdown of cyclic AMP. They are indicated for short term treatment of refractory heart failure. They reduce the pulmonary and systemic vascular resistance and

have a favourable effect on myocardial oxygen consumption. Long-term administration increases the mortality in chronic failure.

Dose

Amrinone—750 $\mu\text{g}/\text{kg}$ bolus followed by 2.5 to 10 $\mu\text{g}/\text{kg}/\text{minute}$.

Milrinone—50 $\mu\text{g}/\text{kg}$ bolus followed by 0.5 to 0.75 $\mu\text{g}/\text{kg}/\text{minute}$.

Adverse effects: Cardiac arrhythmias and thrombocytopenia.

Mechanical Circulatory Support

This may be considered when medical measures fail either in transient myocardial dysfunction or when alternative procedures like CABG or cardiac transplantation are planned.

- Intra-aortic balloon pump
- Ventricular assist devices (Fig. 3.134)
- Enhanced external counterpulsation
- Resynchronisation therapy/biventricular pacing (Fig. 3.135).

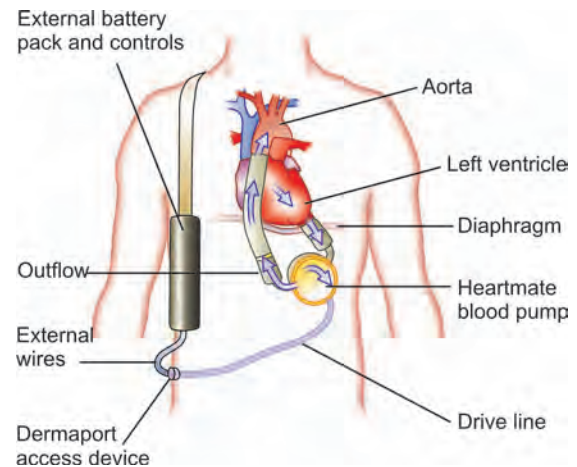

Fig. 3.134: Left ventricular assist device

Cardiac resynchronisation therapy or biventricular pacing in cases of refractory failure with conduction abnormalities like LBBB may be beneficial.

Management of cardiogenic pulmonary oedema:

- Strict bed-rest to reduce cardiac workload.
- Sitting position to improve pulmonary function by relieving pulmonary congestion.
- Oxygen by nasal cannula or mask to raise PaO_2 more than 60 mm of Hg.
- Morphine sulphate* (2 to 5 mg IV) is used to relieve anxiety and it results in pulmonary and systemic venous dilatation.

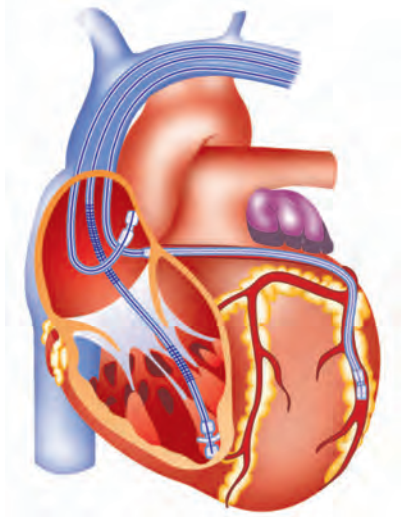

Fig. 3.135: Cardiac resynchronisation therapy by pacing

5. *Furosemide*—A potent venodilator 40 to 80 mg IV relieves pulmonary congestion even before the commencement of diuresis.
6. *Nitroglycerin* (5 µg/minute) potentiates the effect of furosemide. Avoid hypotension and keep the systolic pressure above 90 mm of Hg.
7. *Nitroprusside* is more useful in pulmonary oedema resulting from valvular regurgitant lesions or systemic hypertension.
8. *Dobutamine-dopamine-phosphodiesterase inhibitors* are used in the presence of cardiogenic shock.
9. *Aminophylline*—250 to 500 mg slow IV is given in some cases to relieve bronchoconstriction and to augment myocardial contractility.
10. Mechanical aids: a) Rotating tourniquets b) Phlebotomy.
11. Treat the precipitating cause.

Systemic Hypertension (Fig. 3.136)

Seventh Report of the Joint National Committee: (JNC 7)

Category	Systolic pressure (mm Hg)	Diastolic pressure (mm Hg)
Normal	< 120	< 80
Pre-hypertension	120-139	80-89
Hypertension		
Stage 1	140-159	90-99
Stage 2	> 160	> 100
Isolated systolic Hypertension	> 140	< 90

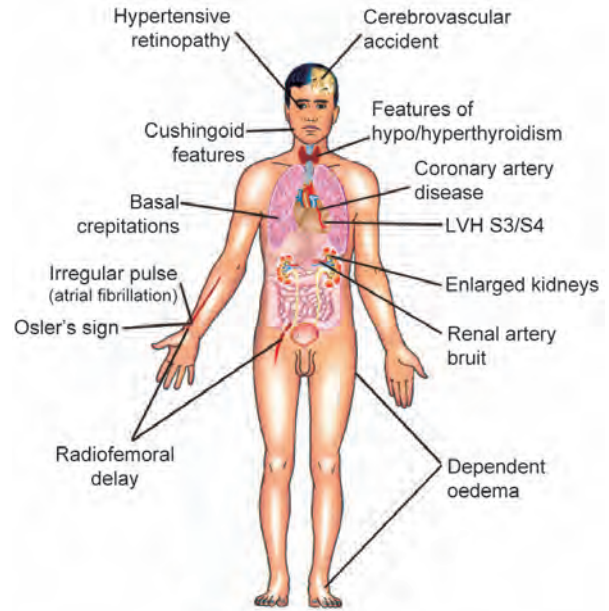

Fig. 3.136: Systemic hypertension

Primary (Essential)—94%

Secondary—6%

Renal (4%)

Vascular

Parenchymal

Renal artery stenosis

Glomerulonephritis (acute/chronic)

Chronic pyelonephritis

Polycystic kidneys

Amyloidosis

Diabetes.

Endocrine (1%)

Acromegaly

Hyperthyroidism

Hypothyroidism

Hyperparathyroidism

Cushing's syndrome

Conn's syndrome

Pheochromocytoma.

Miscellaneous (1%)

Drugs

1. Steroids

Anabolic steroids

Corticosteroids

Oral contraceptive pills

2. Cyclosporine

3. Beta receptor agonists

4. Sympathomimetics (Cold remedies/Nasal drops)

5. NSAIDs.

Coarctation of aorta.



Causes of Isolated Systolic Hypertension

1. Atherosclerosis (old age)
2. Coarctation of aorta
3. Severe AR
4. Thyrotoxicosis.

Factors Influencing Prognosis

I. Used for Risk Stratification

- a. Levels of systolic and diastolic BP (grade I-III)
- b. Men > 55 years
- c. Women > 65 years
- d. Smoking
- e. Total cholesterol 250 mg%
- f. Diabetes mellitus
- g. Family history of pre-mature CVD

II. Other Factors Adversely Influencing Prognosis

- a. Reduced HDL cholesterol
- b. Raised LDL cholesterol
- c. Micro-albuminuria in diabetes/HT
- d. Impaired glucose tolerance
- e. Obesity
- f. Sedentary lifestyle
- g. Raised fibrinogen
- h. High-risk socio-economic group
- i. High risk ethnic group
- j. High risk geographic region

III. Target Organ Damage (TOD)

- a. LVH
- b. Proteinuria or slight elevation of plasma creatinine (1.2-2 mg%)
- c. Radiological evidence of atherosclerotic plaque (carotid, femoral, iliac, aorta)
- d. Generalised or focal narrowing of retinal arteriole

IV. Associated Clinical Conditions (ACC)

- a. Cerebrovascular disease (infarcts, haemorrhages, TIA)
- b. Heart disease (MI, angina, CCF, coronary revascularisation)
- c. Renal disease (nephropathy, renal failure—P. creatinine > 2 mg%)
- d. Vascular disease (dissecting aneurysm, symptomatic arterial disease)
- e. Advanced hypertensive retinopathy (grade III and IV)

Risk stratification to quantify prognosis

Other risk factors and disease history	BLOOD PRESSURE (mm Hg)		
	Grade I	Grade II	Grade III
I. No other risk factor	Low risk	Medium risk	High risk
II. 1 to 2 risk factors	Medium risk	High risk	Very high risk
III. 3 or > risk factors or TOD or diabetes	High risk	High risk	Very high risk
IV. ACC	Very high risk	Very high risk	Very high risk

Investigations

Investigation of Hypertension (All Patients)

- Urine analysis: protein, glucose, haematuria
- Plasma urea/creatinine
- Chest radiograph (cardiomegaly, heart failure, rib notching)
- ECG (left ventricular hypertrophy, ischaemia)
- Plasma electrolytes (hypokalaemic alkalosis in the absence of diuretic therapy may indicate primary or secondary hyperaldosteronism)
- Plasma cholesterol/triglycerides.

Investigation of Hypertension (Patients Suspected of having Secondary Hypertension)

- Intravenous urogram, ultrasound (if renal disease is suspected)
- Radionuclide renography or renal arteriography (if there is evidence of renal artery stenosis)
- 24 hours urine catecholamines (vanillylmandelic acid—VMA)
- Plasma renin activity and aldosterone (if Conn's syndrome suspected)
- Urinary cortisol, dexamethasone suppression test (if signs of Cushing's syndrome is present)
- Angiography/MRI (if coarctation is suspected).

When to Suspect Secondary Hypertension

- Young patient with hypertension (20 to 40 years)
- No family history of hypertension
- Postural fall of blood pressure
- Malignant hypertension
- Resistant or refractory hypertension.

Evidence of underlying secondary cause (signs or symptoms)

- a. Signs and symptoms of renal parenchymal disease
- b. Truncal obesity and thin limbs (Cushing's syndrome)
- c. Paroxysmal hypertension, sweating, palpitation, fear of impending death (pheochromocytoma)



- d. Disparity in upper and lower limb pulses (coarctation of aorta)
- e. *Renal artery bruit (renal artery stenosis)*: This condition is diagnosed by doing a rapid sequential IVP. There is a delayed appearance and delayed clearance of the contrast media on the affected side.

Malignant hypertension: This presents with manifestations of hypertensive encephalopathy (severe headache, vomiting, visual disturbances, transient paralysis, convulsions, coma), attributed to spasm of cerebral vessels and cerebral oedema. Other presentations are sudden cardiac decompensation and rapidly declining renal function.

The characteristic vascular lesion is fibrinoid necrosis of the walls of the small arteries and arterioles, which can be reversed by effective antihypertensive therapy.

About 1% of hypertensive patients develop malignant hypertension and men are more affected than women.

In the absence of effective antihypertensive therapy, life expectancy after diagnosis of malignant hypertension is two years, and with effective antihypertensive therapy, at least half of the patients survive for more than five years. Most deaths are due to CCF, renal failure or cerebral haemorrhage.



Management

General Principles

Lifestyle Modification—Management of Hypertension

Modification	Recommendation	Approximate reduction – SBP
Weight reduction	BMI 19-25 kg/m ²	5-20 mm Hg/10 kg
Diet	Low fat, vegetables and fruits	8-12 mm of Hg
Sodium restriction	< 6 g of sodium chloride	4-8 mm of Hg
Physical activity	Brisk walking 40 min/day	4-8 mm of Hg
Alcohol restriction	Avoid or limit consumption	2-4 mm of Hg

- In presence of mild hypertension, a trial of non-drug therapy (diet, weight reduction, exercise and relaxation), must be given for a period of 3–6 months.
- Drug therapy must be instituted when there is a persistent elevation of diastolic blood pressure of

more than 95 mm Hg in males and more than 100 mm Hg in females or when diastolic blood pressure is more than 90 mm Hg in any individual with increased risk factors like smoking, DM, family history of hypertension, hyperlipidaemia, or with increased risk of complications secondary to hypertension, or with evidence of end organ damage.

- Drug therapy must be instituted with as few drugs as possible, in the minimum optimal dosage so as to avoid drug interactions, minimise adverse effects of the drugs and to improve patient compliance.

Non-Drug Therapy

1. Diet

- Weight reduction in obese and overweight patients (Aim: BMI < 25 kg/m²)
- Avoid excess salt consumption (advised to restrict salt intake to 3 to 4 gm/day; normal daily salt consumption is about 10 gm/day)
- Avoid alcohol
- Fat restriction (saturated, mono and polyunsaturated fatty acids each 10%, cholesterol less than 300 mg/day)
- Calcium, magnesium and potassium supplementation
- Fresh food preferred to processed food (as processed food has increased salt content and decreased potassium content).

2. Exercise and Relaxation

- Regular exercise programme (isotonic exercise)
- Avoid isometric exercise
- Meditation.

3. Smoking

- Smoking should be stopped as it constitutes the single most important and effective risk reduction.

Drug Therapy

Strategy for drug therapy in hypertension

- Step-wise approach is no longer advocated
- Confirm that hypertension is present on repeated measurements
- Determine whether drug therapy is required
- Thiazide diuretic may be initiated as first line treatment, especially in the elderly (especially in those with isolated systolic hypertension)
- β -adrenoceptor antagonists can be used in combination with a thiazide especially relevant in presence of angina
- Calcium antagonists and α -blockers may be used when β -adrenoceptor antagonists are contraindicated or not tolerated



- Young hypertensive – (Renin ↑) Use beta-blockers and ACE inhibitors
- Elderly hypertensive – (Renin ↓) Use diuretics and calcium channel blockers
- Angiotensin converting enzyme inhibitors may be used where first line treatment fails, or may be used as an alternative to β -adrenoceptor antagonist or calcium antagonist
- β -blockers, calcium channel blockers and ACE inhibitors can be used individually as first line drugs
- There is an individualised approach to drug therapy
- Always select a single appropriate drug
- Start with minimal dose of drug and then titrate to achieve optimal dose
- If the drug in optimal dose does not give the desired result, in order to avoid adverse effect of that drug as a result of increasing its dose, another appropriate drug can be added to achieve the desired effect
- Treatment is life long
- In the course of treatment, 25% of mild hypertensives can become normotensives for a duration of one year or so without drugs. The patient requires frequent monitoring at this stage as the BP may rise at a later date and patient will require re-introduction of the antihypertensive drugs.

Drug Therapy for Hypertension

BP classification	Drugs advocated
Pre-hypertension	Life-style modification and no drugs
HTN – Stage 1	Thiazide, ACEI, ARB, BB, CCB
HTN – Stage 2	Combined use of above drugs

Diuretics

- Thiazides can be used only when renal function is intact
- Loop diuretics can be used in presence of impaired renal function
- Long acting diuretics (chlorthalidone, indapamide, metolazone) are preferable for 24 hour control of BP
- Metolazone is useful in patients with normal renal function
- Potassium sparing diuretics may be used in borderline hypertension (must be avoided in renal failure and in combination with ACE inhibitors).

Adverse Effects of Thiazides

- Hyperglycaemia (due to decreased insulin secretion as a result of hypokalaemia induced by the diuretic, increased insulin resistance due to increased catecholamines, and increased hepatic glycogenolysis)

- Hyperlipidaemia
- Hyperuricaemia
- Hypercalcaemia
- Hypokalaemia
- Hyponatraemia
- Hypomagnesaemia

β -blockers

β -blockers may be cardioselective or non-cardioselective.

Non-cardioselective β -blockers are:

- Without intrinsic sympathomimetic activity (propranolol, nadolol, timolol, sotalol, tertalol).
- With intrinsic sympathomimetic activity (pindolol, cartelol, alprenolol, oxprenolol, dilevalol, penbutolol).

Cardioselective β -blockers are:

- Without intrinsic sympathomimetic activity (atenolol, metoprolol, bevantolol, bisoprolol, betaxolol)
- With intrinsic sympathomimetic activity (Acebutolol, celiprolol).

β -blockers with added alpha blocking activities are:

- Labetalol (used in the dose of 200 to 1200 mg/day; useful in pheochromocytoma, hypertensive crisis and acute aortic dissection; to be used with caution in pregnancy; may cause postural hypotension, paraesthesia, tremor, cholestatic jaundice, positive antinuclear antibody.
- Bucindolol.
- Carvedilol.

Ultra short acting β -blockers are:

- Esmolol
- Flestolol

and they are useful for intraoperative control of hypertension as their dose can be easily titrated due to their short half-lives.

Lipophilic β -blockers penetrate the CNS and dreams are common (propranolol, metoprolol, oxprenolol, labetalol).

Hydrophilic β -blockers have a prolonged action, and dreams are uncommon (atenolol, sotalol, nadolol, practolol).

Route of elimination of β -blockers is as follows:

- By liver (propranolol, metoprolol, labetalol)
- By kidney (atenolol, sotalol, nadolol).

The following are indications for β -blockers:

- Young hyperkinetic hypertensive
- Hypertension with IHD
- Marked anxiety, perioperative stress
- Thyroid disorder with hypertension.



- β -blockers with ISA can be used in hypertensives with:
- Hyperlipidaemia
 - Peripheral vascular disease
 - In presence of bradycardia.

The following are contraindications for β -blockers:

- Complete heart block
- Bronchial asthma
- Hyperlipidaemia
- Peripheral vascular disease
- Diabetes mellitus (use with caution).

Doses of commonly used β -blockers are:

- Metoprolol (100 to 200 mg/day)
- Atenolol (50 to 100 mg/day)
- Pindolol (15 to 30 mg/day)
- Oxprenolol (160 to 320 mg/day)
- Nebivolol (5 to 10 mg/day)

It is selective β_1 -blocker and it has added endothelial nitrous oxide mediated vasodilator effect.

Other indications for β -blockers are:

- Migraine
- Tremors
- MVPS
- TOF
- To prevent reinfarction
- In patients with family history of sudden death
- Congestive cardiac failure (Class II and Class III – carvedilol)
- Thyrotoxicosis.

Centrally Acting Adrenergic Inhibitors

The drugs belonging to this category are:

- Methyldopa (500–2000 mg)
- Clonidine (0.2–2 mg)
- Guanabenz (4–16 mg).
 - These drugs (b and c) have a favourable effect with lipid metabolism and have no effect on carbohydrate and uric acid metabolism.
 - The cardiovascular response to exercise is preserved.
 - It reduces left ventricular hypertrophy.
 - Rebound hypertension can occur with sudden withdrawal of drug.
 - It can cause postural hypotension.
 - Tachyphylaxis can occur with prolonged use, especially with Methyldopa
 - Long-term use can result in sodium retention (except guanabenz).

The following are the adverse effects noticed:

- Dry mouth, drowsiness, sexual dysfunction (common for all drugs).

- Depression, drug fever, galactorrhoea, haemolytic anaemia, positive antinuclear antibody (for methyldopa).

The following are the indications for using these drugs:

- Hypertension with hyperlipidaemia (clonidine, guanabenz)
- Pregnancy (methyldopa)
- Hypertension with left ventricular hypertrophy
- Clonidine may be used in diagnosis of pheochromocytoma and for GH assay.

Peripherally Acting Adrenergic Inhibitors

The drugs belonging to this category are:

- Reserpine* (0.01–0.5 mg/day): An effective and inexpensive drug useful in mild hypertension; postural hypotension common; sodium retention occurs and has to be used with diuretics; side effects are peptic ulceration, depression, drowsiness, suicidal tendencies, nasal congestion, weight gain, impotence, bronchospasm, dysrhythmias and extra pyramidal symptoms.
- Guanethidine* (10–300 mg/day) used in severe hypertension when other drugs fail; postural hypotension common; sodium retention may occur and has to be used with a diuretic; side effects are impotence, retrograde ejaculation, diarrhoea, weakness, nasal congestion, bradycardia, azotaemia.

Alpha Adrenergic Inhibitors

The drugs belonging to this category are:

- Prazosin (6–15 mg)
- Terazosin (5–20 mg)
- Doxazosin (1–16 mg).
 - These are powerful vasodilators
 - They cause postural hypotension
 - They reduce cholesterol, LDL, VLDL and increase HDL
 - Dose modification is necessary in hepatic insufficiency.
 - Useful in renal insufficiency
 - Phentolamine and Phenoxybenzamine are used in controlling hypertension in pheochromocytoma and are used perioperatively in surgery for pheochromocytoma.

Indications for using these drugs are:

- Hypertension with hyperlipidaemia
- CCF/shock
- Angina with hypertension
- Hypertension with cardiac arrhythmias
- Hypertensive crisis



- f. Pheochromocytoma
- g. Hypertension with Raynaud's phenomenon
- h. Hypertension with benign prostatic hypertrophy
- i. Hypertension with COPD/pulmonary hypertension.

Calcium Channel Blockers

The drugs belonging to this category are:

- a. Verapamil (120–480 mg/day)
- b. Diltiazem (90–360 mg/day)
- c. Nifedipine (10–180 mg/day)
- d. Amlodipine (5–10 mg/day)
- e. Nicardipine (20–40 mg/day)
- f. Isradipine (2.5–10 mg/day)
- g. Felodipine (5–20 mg/day)
- h. Nitrandipine (5–20 mg/day).

The indications of calcium channel blockers are:

- a. Hypertension with renal dysfunction
- b. Hypertension with COPD
- c. Hypertension with peripheral vascular disease
- d. Hypertension with angina
- e. Hypertension with cardiac arrhythmias.

The pharmacological effects of these drugs are as follows:

Characteristics	Diltiazem	Verapamil	Nifedipine	Nicardipine
Heart rate	D	D	I	I
Myocardial contractility	D	DD	D	–
Nodal conduction	D	DD	–	–
Peripheral vasodilation	I	I	II	II

D = Decreased I = Increased

Adverse effects of calcium channel blockers are:

- a. Headache
- b. Hypotension
- c. Flushing
- d. Bradycardia
- e. Dizziness
- f. Dysrhythmias
- g. Palpitation
- h. Constipation
- i. Sexual dysfunction and depression (low incidence)
- j. Ankle oedema.

All calcium channel blockers are metabolised in liver and hence dose modification is required in cirrhosis liver.

ACE Inhibitors

The drugs belonging to this category are:

- a. Captopril (25–75 mg/day)

- b. Enalapril (5–40 mg/day)
- c. Lisinopril (5–40 mg/day)
- d. Bendopril (5–40 mg/day)
- e. Fosinopril (10–40 mg/day)
- f. Quinapril (2.5–10 mg/day)
- g. Ramipril (1.25–10 mg/day)
- h. Imidapril 5-10 mg/day.

The advantages of ACE inhibitors are:

- a. Improved general well-being
- b. Absence of mental depression, sleep disturbance
- c. Absence of fatigue, sexual dysfunction
- d. Does not precipitate CCF, bronchospasm, nasal congestion, bradycardia, peripheral vascular disease, flushing
- e. Does not cause hyperglycaemia, hyperuricaemia, hyperlipidaemia, hypokalemia, fluid retention, tachyphylaxis, reflex tachycardia, rebound hypertension.

ACE inhibitors can be used in the following situations:

- a. CCF
- b. Renal insufficiency (creatinine less than 3 mg)
- c. Diabetic nephropathy (it can reverse the early microalbuminuria of diabetic nephropathy)
- d. Hypertension with LVH
- e. Hypertension with hyperlipidaemia
- f. Renovascular hypertension (avoid in bilateral renal artery stenosis).

Adverse effects of ACE inhibitors are:

- a. Angioedema
- b. Cough
- c. Loss of taste
- d. Potassium retention
- e. Skin rashes
- f. Proteinuria
- g. Neutropenia.

AT₂ Receptor Blockers

They inhibit the renin angiotensin system via specific blockade of the AT₂ receptors. In contrast to ACE inhibitors they do not increase bradykinin levels, which may be responsible for adverse effects such as cough.

Drugs are

1. Candesartan—8 to 16 mg od
2. Irbesartan—75 to 150 mg od
3. Losartan—25 mg od, can be used bid
4. Valsartan—80 mg od
5. Eprosartan—200 to 400 mg od, can be used bid
6. Telmisartan—20 to 40 mg od
7. Olmesartan—20 mg



Directly Acting Vasodilators

The drugs used in this category are:

- a. Hydralazine (25–300 mg/day)
- b. Minoxidil (10–100 mg/day)
- c. Sodium nitroprusside (0.3 to 1 microgram/kg/min IV)
- d. Diazoxide (50 to 150 mg IV bolus rapidly).

These drugs induce sodium and water retention and reflex tachycardia. They are effective when combined with β -blockers and diuretics. They may be used in the following situations:

- a. Mild and moderate hypertension
- b. CCF
- c. Renal hypertension
- d. Pregnancy (hydralazine)
- e. Refractory hypertension
- f. Renal failure
- g. Diazoxide and sodium nitroprusside are useful in hypertensive crisis.

Refractory hypertension: Refractory or resistant hypertension is defined as failure to achieve a blood pressure of 140/90 mm Hg despite the use of a rational triple-drug regimen of the following drugs.

1. Oral diuretic (equivalent to 25 mg of hydrochlorothiazide or chlorthalidone or 320 mg of furosemide or 10 mg of metolazone per day)
plus
2. Sympathetic inhibitor (propranolol 320 mg/day or atenolol 100 mg/day or clonidine 0.6 mg/day or prazosin 20 mg/day or methyldopa 2 gm/day)

or

Other agents (ACE inhibitors like captopril 200 mg/day or benazepril 40 mg/day)

or

Angiotensin II receptor blocker (losartan potassium 100 mg/day)

or

Calcium channel blocker (verapamil 480 mg/day or nifedipine 120 mg/day or diltiazem 360 mg/day)

3. Direct vasodilator (hydralazine 100 mg/day or minoxidil 20 mg/day).

Most causes of resistant hypertension are due to non-compliance on part of the patient in adhering to a strict diet and drug dosage schedule, or due to use of other medications and substances that may interfere with blood pressure control (NSAIDs, nasal decongestants, OCPs, steroids, carbenoxolone) or presence of underlying renal artery stenosis or other causes of secondary hypertension (endocrine hypertension).

A systematic approach to the problem, keeping the above factors in mind, usually reveals the cause of resistant hypertension. The correction of these factors usually result in adequate control of blood pressure.

The adverse effects of these drugs are:

- a. Hydralazine (headache, nausea, emesis, tachycardia, postural hypotension, positive antinuclear antibody, SLE)
- b. Minoxidil (weight gain, hypertrichosis, hirsutism, pericardial effusion).

Vasodilators act on arteries and veins. The relative action of vasodilators on arteries and veins are as follows:

- | | |
|-----------------------------|--------|
| a. Sodium nitroprusside | A = V |
| b. Alpha blockers | A = V |
| c. Diazoxide | A > V |
| d. ACE inhibitors | A > V |
| e. Hydralazine | A >> V |
| f. Minoxidil | A >> V |
| g. Calcium channel blockers | A >> V |
| h. Nitroglycerin | V > A |

A = Artery; V = Vein

Potassium Channel Openers

Drugs are diazoxide, minoxidil, pinacidil, nicorandil, cromakalim and lomakalim. These drugs open potassium channels of vascular smooth muscle, causing their relaxation and thereby vasodilatation.

Peripheral arterial vasodilatation decreases peripheral vascular resistance, thereby decreasing blood pressure. It causes reflex tachycardia.

Dose

- a. Pinacidil (12.5 mg bid upto maximum of 75 mg/day)
- b. Nicorandil (20 mg od).

Antihypertensives and Uric Acid and Glucose Metabolism and Electrolyte Changes

Drugs	Uric acid	Glucose	Electrolytes	
			K	Mg
Diuretics	I	I	D	D
β -blockers	I	I	-	-
Labetalol	I	I	-	-
ACE inhibitors	-	-	I	D
Calcium channel blockers	-	I	-	-

D = Decreased I = Increased

Central adrenergic inhibitors have no effect on the above parameters.

Antihypertensives and Lipid Metabolism

Drugs	Total cholesterol	VLDL	Triglycerides	LDL	HDL
Diuretics	↑	↑	↑	↑	↓
β-blockers (without ISA)	↑	↑	↑	↑	↓
β-blockers (with ISA)	-	-	↓	-	↑
Methyldopa	-	↑	↑	-	↓
Reserpine	↑	-	↑	↑	↓
Clonidine	↓	↓	↓	↓	↑
α-blockers	↓	↓	↓	↓	↑
Guanabenz	↓	↓	↓	↓	↑

ACE inhibitors and calcium channel blockers have some favourable effect on lipid metabolism.

Effects of Antihypertensives on LV Mass, Sexual Dysfunction and Postural Hypotension

Drugs	LV mass	Sexual dysfunction	Postural hypotension
Diuretics	I	-	-
β-blockers	inconsistent	I	-
Labetalol	D	I	I
Clonidine	D	I	-
Methyldopa	D	I	I
Reserpine	D	I	-
α-blockers	D	-	I
ACE inhibitors	D	-	-
Calcium channel blockers	D	low	+/-

D = Decreased I = Increased

Special Considerations in Antihypertensive Therapy

- Pregnancy**
 - Safe drugs are hydralazine, methyldopa, clonidine, metoprolol, prazosin.
 - Drugs that can be used with caution are labetalol, *propranolol, diazoxide, nifedipine, nitroprusside.
 - Drugs to be avoided are thiazides, ACE inhibitors.

Note: *It can cause IUGR if given early in pregnancy.
- Elderly**
 - Drugs preferred are diuretics and calcium channel blockers.
 - Adrenergic inhibitors to be used with caution.
- Anaesthesia**
 - Short acting β-blockers like esmolol is preferred for control of hypertension perioperatively; The alternative drugs are sodium nitroprusside and trimethaphan.
- Renal failure**

Drugs preferred are diuretics (frusemide), calcium channel blockers, ACE inhibitors, β-blockers (propranolol, metoprolol), α-blockers.

- Ischaemic heart disease**
 - Calcium channel blockers and β-blockers are preferred
 - In presence of CCF, ACE inhibitors, α-blockers are used.
 - If ejection fraction is < 30%, β-blockers can be used with caution, but calcium channel blockers are contraindicated.
- Diabetes mellitus**
 - Preferred drugs are ACE inhibitors, calcium channel blockers and α-blockers.
- Arrhythmias**
 - Sinus bradycardia Nifedipine, α-blockers
 - Sinus tachycardia β-blockers
 - SVT Verapamil, β-blockers
 - AV block Nifedipine
- COPD**
 - Calcium channel blockers, ACE inhibitors, α-blockers.
- Peripheral vascular disease**
 - Calcium channel blockers, α-blockers.
- Subarachnoid haemorrhage**
 - Nimodipine.
- Aortic dissection**
 - Acute (nitroprusside, esmolol, propranolol, labetalol, nifedipine).
 - Chronic (calcium channel blockers, β-blockers, methyldopa, clonidine, reserpine).
- Hyperlipoproteinaemia**
 - Clonidine, guanabenz and α-blockers have a favourable effect on lipid metabolism.
 - Other drugs that can be used are ACE inhibitors, calcium channel blockers and β-blockers with ISA.
- Left ventricular hypertrophy**
 - Drugs like α-blockers, reserpine, clonidine, a methyldopa and ACE inhibitors have been shown to reduce left ventricular hypertrophy.

Compelling Indications for Antihypertensive Drugs

Disorder	Diuretics	BB	ACEI	ARB	CCB	Aldo-Ant
Heart failure	*	*	*	*	—	*
Post MI	—	*	*	—	—	*
High risk CAD	*	*	*	—	*	—
Diabetes	*	*	*	*	*	—
Chronic KD	—	—	*	*	—	—
Recurrent stroke	*	—	*	—	—	—



Management of Hypertensive Crisis

It is not appropriate to attempt to cause an instantaneous fall in blood pressure. Too rapid a fall may cause cerebral damage, including blindness and may sometimes precipitate coronary or renal insufficiency. Even in the presence of cardiac failure or hypertensive encephalopathy, a controlled reduction over a period of 30–60 minutes to a level of about 160/100–110 mm of Hg is adequate. IV antihypertensive agents are preferred in hypertensive encephalopathy and oral antihypertensive agents in cardiac failure. The drugs used in the management of hypertensive crisis are:

- Sodium nitroprusside (0.3 to 1 $\mu\text{g}/\text{kg}/\text{min}$ upto a maximum of 6 $\mu\text{g}/\text{kg}/\text{min}$ as an IV infusion)
- Labetalol (2 mg/min upto a maximum of 200 mg IM or IV)
- Hydralazine (5 to 10 mg aliquotes, repeated half hourly upto a maximum of 300 mg)
- Oral clonidine loading – Initial dose of 0.2 mg followed by 0.1 mg every hour to a total dose of 0.7 mg. Check the BP in every 15 minutes. After 6 hours a diuretic can be given. By this method, reduction of diastolic BP upto 20 mm of Hg can be achieved.
- Diazoxide (50 to 150 mg IV bolus rapidly, as it has high affinity to bind to albumin, upto a maximum of 600 mg/day)
- Nicardipine IV infusion 5–15 mg/hr
- Enalaprilat IV bolus 1.25–2.5 mg 6th hourly
- Nitroglycerine IV drip is useful in the management of hypertensive crisis associated with ischaemia.

Do not use sublingual nifedipine as it could cause excessive reduction in BP resulting in adverse effect such as stroke or MI.



Complications of Hypertension

Adverse effects of hypertension principally involve the central nervous system, the retina, the heart and the kidneys.

Central Nervous System

Hypertension induced complications of central nervous system are:

- Carotid atheroma and transient cerebral ischaemic attacks
- Cerebral infarction
- Cerebral haemorrhage
- Subarachnoid haemorrhage
- Hypertensive encephalopathy (it is characterised by very high blood pressure and neurological symp-

toms like transient disturbances of speech or vision, paraesthesiae, disorientation, fits and loss of consciousness. Papilloedema is common. The neurological deficiency is usually reversible if hypertension is properly controlled)

- Cognitive impairment and dementia.

Retina

The optic fundi reveal a gradation of changes linked to the severity of hypertension. They provide a clue to the arteriolar damage occurring elsewhere. There are four grades of hypertensive retinopathy depending on the severity and duration of hypertension.

Cardiovascular System

Hypertension induced complications of cardiovascular system are:

- Left ventricular hypertrophy (LVH) as a result of pressure overload. LVH is reversible with certain antihypertensive agents.
- Left ventricular failure
- Coronary artery disease
- Aortic aneurysm
- Aortic dissection.

Kidneys

Hypertension can lead to damage of the renal vessels. Longstanding hypertension can cause proteinuria and progressive renal failure.

Microalbuminuria is an earlier marker of hypertensive nephropathy.

The pathological change noticed in longstanding hypertension is benign nephrosclerosis. Fibrinoid necrosis is noticed in malignant hypertension.

Acute Coronary Syndromes (ACS)

This syndrome includes unstable angina, and non-ST elevation myocardial infarction (NSTEMI).

ACS is a spectrum of disease characterised by either one of the following:

- New-onset angina
- Angina at rest
- Progression of angina of increasing frequency or severity
- Angina in response to lower levels of exertion.

ACS most often represents acute atherosclerotic plaque rupture with exposure of thrombogenic sub-endothelial matrix. Thrombus formation, which may be episodic in nature and it is the mechanism by which it interferes with coronary blood flow (Fig. 3.137).

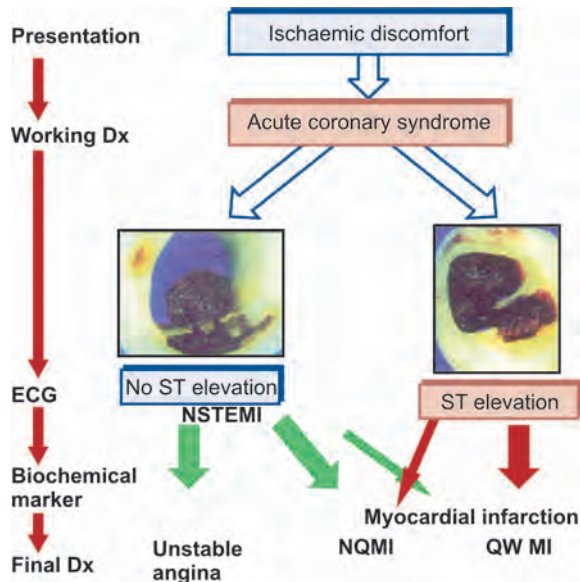

Fig. 3.137: Acute coronary syndromes

Unstable Angina

It is due to dynamic obstruction of coronary artery – spasm and or rupture of plaque.

It is defined as angina pectoris or equivalent ischaemic discomfort with either one feature.

1. It occurs at rest or with minimal exertion usually lasting > 10 minutes.
2. It is severe and of new onset within the prior 4-6 weeks.
3. It has a crescendo pattern of pain – distinctly severe, prolonged and more frequent than before.

Unstable angina is distinguished from non-ST-elevation myocardial infarction by the absence of elevated serological markers of myocardial necrosis. It is also distinguished from ST-elevation MI by the absence of persistent ST segment elevation.

Pathogenesis

1. Plaque rupture or erosion with superimposed non-occlusive thrombus (most common)
2. Progressive mechanical obstruction – either rapidly advancing coronary atherosclerosis or restenosis following percutaneous coronary intervention.
3. Increased discrepancy between myocardial oxygen demand and supply.



Management (Fig. 3.138)

Immediately assess the following:

- Clinical evaluation – history and physical examination

- 12 – lead ECG recording
- Measurement of cardiac specific markers – troponin and CK-MB.

All ACS patients should be placed on aspirin, β -blocker, nitrate and clopidogrel immediately.

Low risk patients – On observation if the patient remains pain-free with normal ECG and normal levels of cardiac markers, submit them for stress ECG. If the stress test is negative, consider alternative diagnosis. If the stress test is positive, continue medication and invasive testing when required.

Intermediate and high risk patients – Patient has to be admitted in the intensive care unit and to be managed with anti-ischaemia, antiplatelet and anticoagulant group of drugs. In the meantime coronary angiography is planned.

Antiplatelet Therapy

- A. Aspirin (loading dose of 325 mg followed by 75-150 mg/day after lunch) reduces subsequent MI and cardiac death.
- B. Clopidogrel (loading dose 300 mg followed by 75 mg/day) in aspirin intolerant patients.

Added benefit in reducing the mortality is achieved by combining both aspirin and clopidogrel and can be used for a minimum of one month if PCI is planned or maximum of 9 months.

- C. Glycoprotein (GP) IIb/IIIa antagonists – abciximab (ReoPRO) or eptifibatide (Integrilin) or tirofiban (Aggrastat) should be considered for high risk patients. They should be used in conjunction with heparin. If early invasive strategy is planned any one of the molecule can be used. If early invasive strategy is not planned, one of the small molecule either eptifibatide or tirofiban can be used.

Anticoagulant Therapy

Dalteparin – (Fragmin) 120 IU/kg SC 12 hr (Maximum 10,000 IU bid)

Enoxaparin – (Lovenox) 30 mg IV bolus followed by 1 mg/kg SC bid

Heparin (unfractionated -UFH) 60-70 U/kg (maximum 5000 U) IV followed by infusion 12-15 u/kg/hr (Initial maximum 1000 U/hr) titrated to achieve a PTT 1.5-2.5 times control.

Compared with UFH, LMWH produces more predictable anticoagulant response because of the better bioavailability, longer half-life and dose independent clearance. Enoxaparin 1 mg/kg bid subcutaneously is the only LMWH found to confer greater cardiac benefit.

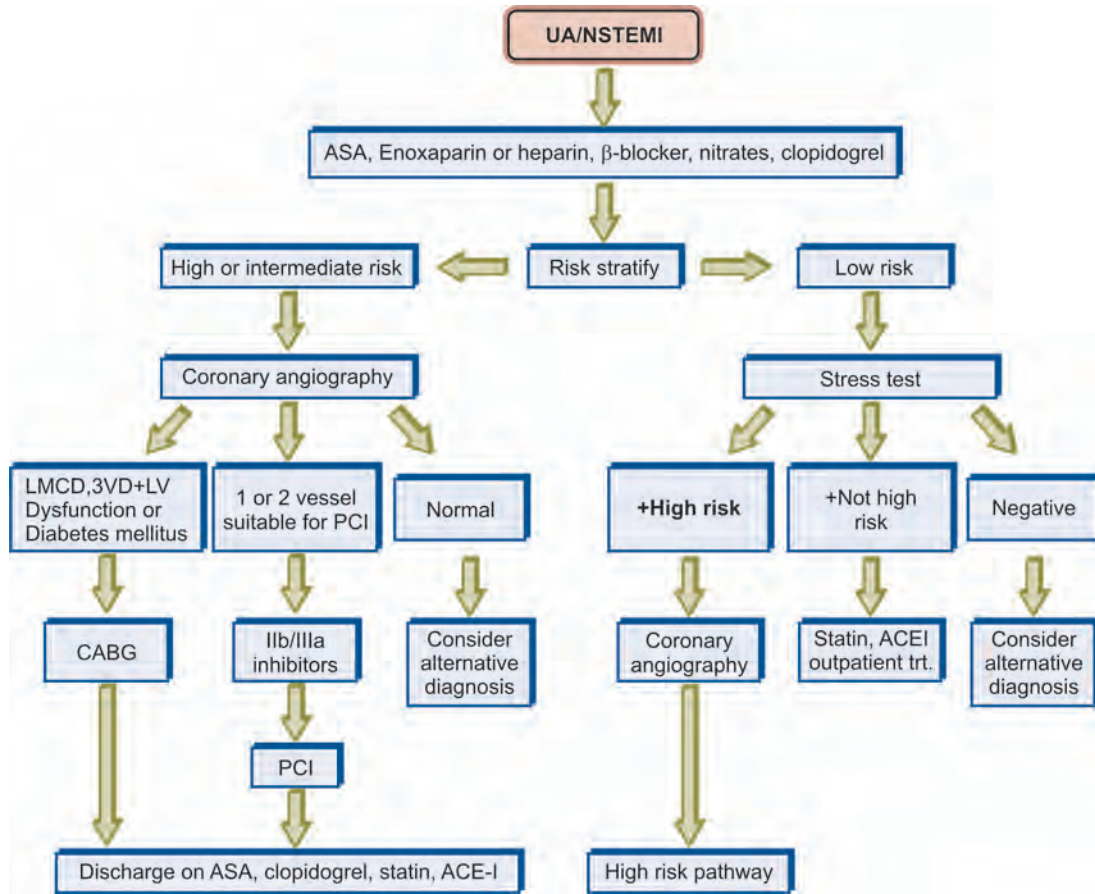

Fig. 3.138: Acute management of unstable angina or non-ST elevation myocardial infarction

Risk Stratification of ACS

Features	High risk	Intermediate risk	Low risk
Clinical history	Accelerating tempo of ischaemic symptoms in preceding 48 hours	Prior MI, peripheral or cerebrovascular disease, CABG or prior aspirin use	
Classical pain	Prolonged ongoing > 30 min rest pain	Prolonged > 20 min rest angina, now resolved, with high likelihood of CAD, rest angina < 20 min relieved with SL-TNG	New-onset or Progressive angina in the past 2 weeks with moderate or high likelihood of CAD
Clinical findings	Pulmonary oedema, Worsening MR, S ₃ , Hypotension, tachycardia, bradycardia, Age > 75 years	Age > 70 years	
ECG	Transient ST changes > 0.05 mV, new bundle branch block or VT	T-wave inversions > 0.2 mV Pathological Q-waves	Normal or unchanged ECG
Biochemical cardiac markers	Elevated troponin or CK-MB (TnT or TnI > 0.1ng/mL)	Borderline elevation (TnT > 0.01 but < 0.1 ng/mL)	Normal

CRP (c-reactive protein) levels > 3 mg/L represent a high risk group.
Thrombolytic therapy is not indicated in ACS.



GP IIb/IIIa receptor inhibitors in ACS -IV

Features	Abciximab	Eptifibatide	Tirofiban
Drug type	Monoclonal antibody	Cyclic heptapeptide	Nonpeptide
Dosage	0.25 mg IV bolus then 0.125 mg/kg/min (max 10 µg/min) × 12 hr-ACS planned for PCI	180 µg/kg bolus then 2 µg/kg/min × 24-48 hours	0.4 µg/kg/min for 30 min, then 0.1 µg/ kg/min × 24-48 hrs
Metabolism	Cellular catabolism	Renal – modify dose in renal failure	Renal – modify dose in renal failure
Recovery of platelet inhibition	48-96 hrs	4-6 hrs	4-6 hrs
Reversibility	Platelet transfusion	None	None

Coronary Angiography

Coronary angiography is performed for high/intermediate risk patients (Fig. 3.139).

CABG: Left main disease, triple vessel disease, LV dysfunction or diabetes mellitus

PCI: 1 or 2 vessel disease – GP IIb/IIIa inhibitors followed by PCI.

If coronary angiography is normal consider alternative diagnosis.

Myocardial Infarction (MI)

Irreversible necrosis of part of the heart muscle is almost always due to coronary atherosclerosis.

Incidence

5/1000 per year. Fifty per cent of deaths due to MI occur within 1-2 hrs after the onset of symptoms.

Risk Factors**Category I (For which interventions have been proved to lower CVD risks)**

1. Raised LDL cholesterol
2. Reduced HDL cholesterol
3. Atherogenic diet
4. Cigarette smoking
5. Hypertension
6. LVH
7. Thrombogenic factors

Category II (For which interventions are likely to lower CVD risks)

1. Diabetes mellitus

2. Physical inactivity
3. Increased triglycerides
4. Small dense LDL
5. Obesity

Category III (Associated with increased CVD risk that, if modified, might lower risk)

1. Psychosocial factors
2. Increased Lipoprotein a (normal level—0-3 mg/dl)
3. Hyperhomocysteinemias
4. No alcohol consumption
5. Oxidative stress
6. Post-menopausal status

Category IV (Associated with increased CVD risk which cannot be modified)

1. Age
2. Male gender
3. Low socio-economic status
4. Family history of early onset CVD

Symptoms

Anginal pain is of greater severity and is associated with nausea, vomiting, sweating and extreme distress.

Painless infarcts are common in diabetics and in the elderly, due to autonomic neuropathy.

Signs

Tachycardia, bradycardia, VPCs, gallop

There may be hyper or hypotension

Cold and clammy extremities

Cyanosis may be present

Mild pyrexia (< 38.5°C)

Features of complications (LV failure, pulmonary oedema, arrhythmias).

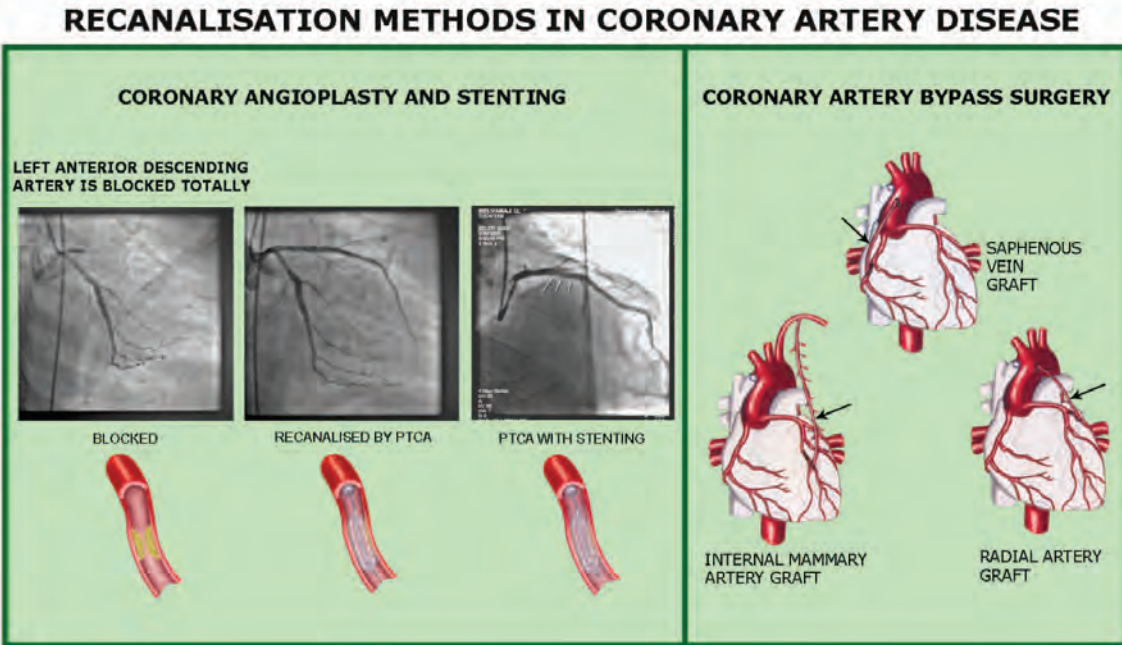
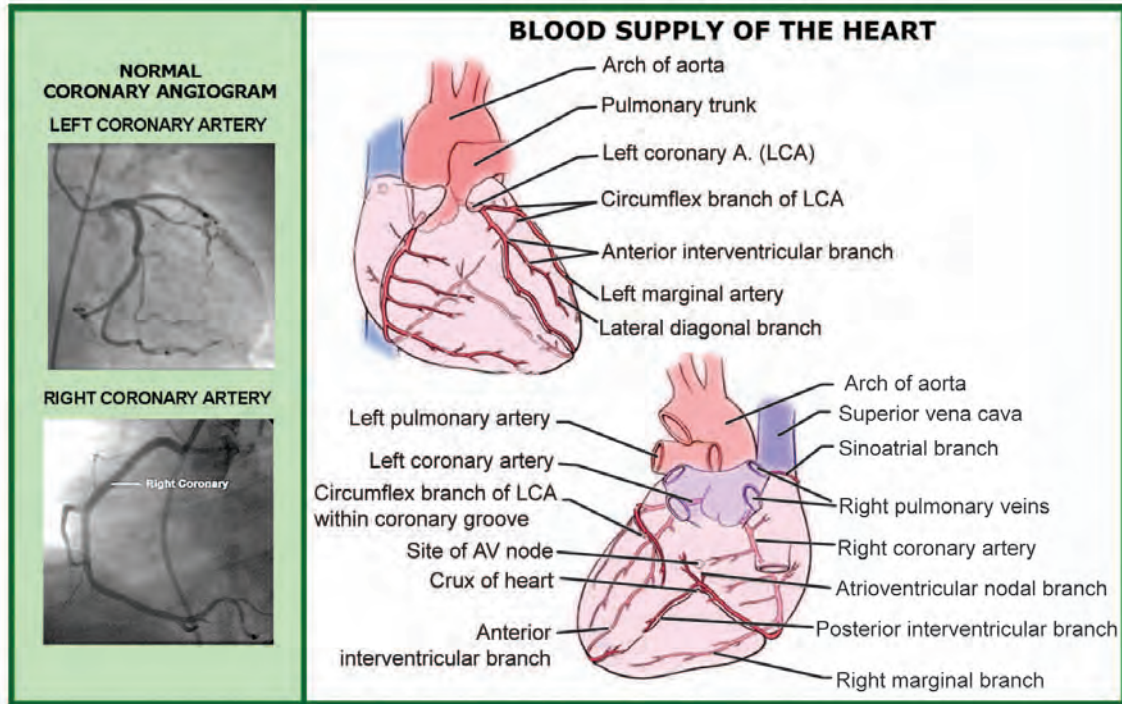

Fig. 3.139: Recanalisation methods in coronary artery disease

Syndrome X

- Ischaemic chest pain in the presence of normal coronary arteries
- It is probably due to microvascular disease of the heart
- Prognosis is good when compared with classic CAD patients.



Investigations

ECG

- May be normal initially and hence serial ECGs must be taken.
- ST elevation and T-wave inversion with pathological Q-waves are typically seen in leads adjacent to the infarcted segment of myocardium.
- Reciprocal ST depression or T-wave inversion in opposite leads.
- A non-Q-wave infarct may occur and has a high risk of mortality (as they are prone to develop dangerous arrhythmias and recurrent angina).

Chest X-ray

Signs of heart failure or pulmonary oedema.

Cardiac Enzymes

- a. *CPK-MB*: This cardiac isoenzyme starts rising within 4–6 hrs after development of acute MI, peaks during the 2nd day (4 fold rise) and disappears in 2–3 days.

Other causes of total CK elevation:

1. Skeletal diseases – Polymyositis, Muscle dystrophy, Myopathies
 2. Electrical cardioversion
 3. Skeletal muscle damage – trauma, convulsions, immobilisation
 4. Hypothyroidism
 5. Stroke
 6. Surgery
- b. *AST*: Starts rising on the 1st day, peaks in 2–3 days (3 fold rise) and disappears by 3rd day.
- c. *LDH₁*: Starts rising by second day, peaks around 3–4 days (3 fold rise) and disappears in 10 days.
- d. *Troponin T*: Cardiac troponin T is a regulatory contractile protein not normally found in blood. Its detection in the circulation has been shown to be a sensitive and specific marker for myocardial cell damage.

Troponin T and I reach a reliable diagnostic level in plasma by 12–16 hrs, maximal activity by 24–32 hrs, returns to normal in 10–12 days.

Troponin I : 0–0.4 ng/ml

Troponin T: 0–0.1 ng/ml

Cardiac troponins are detected in the serum by using monoclonal antibodies. These antibodies have negligible cross reactivity to skeletal muscle. Cardiac troponins I and T start to rise within 3–4 hours after myocardial infarction and remain raised for 4–10 days (Fig. 3.140).

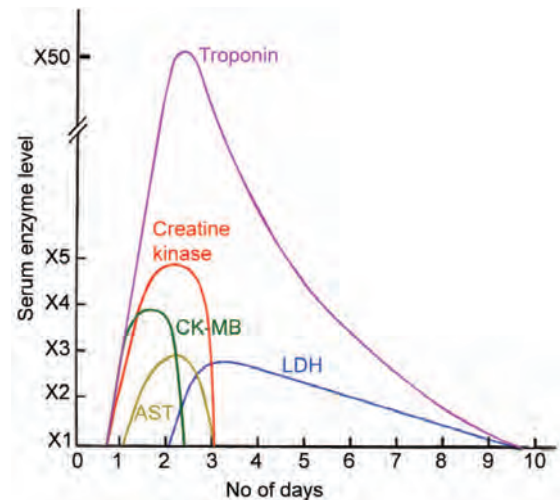

Fig. 3.140: Enzyme levels in acute MI

Other causes of elevated cardiac troponins:

Cardiac causes:

- Cardiac contusion/surgery
- Myocarditis
- Cardiomyopathy
- Heart failure
- Cardioversion
- Percutaneous coronary intervention
- Cardiac amyloidosis
- Radiofrequency ablation
- Supraventricular tachycardia
- Post-cardiac transplantation

Non-cardiac causes:

- Primary pulmonary hypertension
- Pulmonary embolism
- Cerebrovascular stroke
- High dose chemotherapy
- Sepsis and septic shock
- Renal failure
- Critically ill patients
- Scorpion envenomation
- Ultra-endurance exercise (marathon)

- e. *Myoglobin*

It is increased within 2 hrs of onset of symptoms and remains increased for at least 7–12 hrs.

Normal level is 20–100 µg/L.



Complications

Cardiogenic Shock

Cardiogenic shock occurs when > 40% of LV is infarcted and rendered non-functional. It carries a high



mortality rate (80–90%). The criteria for diagnosing cardiogenic shock are:

- Signs of failure like thready pulse, cold and clammy extremities and pallor
- Systolic BP < 80 mm Hg
- Cardiac index < 1.8 L/min/m²
- Left ventricular filling pressure > 18 mm Hg
- Urine output less than 20–30 ml/hr
- Presence of tachycardia and S₃ and S₄ gallop rhythm
- Features of pulmonary oedema.

Treatment of cardiogenic shock with drugs like dopamine, dobutamine, norepinephrine, amrinone or various combinations of these agents or with intra-aortic balloon (or external) counter-pulsation and use of anticoagulants help to lower the mortality. Emergency PTCA or CABG can reduce the mortality by about half.

The prognosis, in the presence of cardiac failure, when untreated, is assessed by using the Killip classification.

Killip Classification

Class	Features	Incidence	Mortality
I	No heart failure	40%	0.5%
II	Mild to moderate heart failure (S ₃ ; rales no more than half way up the back)	40%	10–20%
III	Severe heart failure (pulmonary oedema)	10%	30–40%
IV	Cardiogenic shock	10%	80–90%

Primary PCI

- It is an alternative to thrombolytic therapy in acute MI with ST elevation or resented onset LBBB with acute MI.
- Primary PCI is ideal in acute MI if door to balloon time is < 90 minutes
- Treatment is optimal if angioplasty is performed within 12 hours of onset of symptoms or if the symptoms persist
- PCI is preferred over thrombolysis in patients:
 - Age < 75 years
 - Cardiogenic shock within 36 hours of MI
 - Perform PCI within 18 hours of shock
 - High risk of death or development of CHF
 - Contraindication to fibrinolytic therapy
 - Post CABG or recent PCI

Emergency CABG

It is a high risk procedure and is indicated:

- Coronary anatomy not amenable to PCI
- Failed PCI
- Presence of cardiogenic shock
- If the patient has refractory ischaemia

Emergency Surgery

It is essential in the following situations:

- Papillary muscle rupture
- Ventricular septal defect
- Ventricular aneurysm
- Ventricular free wall rupture
- Intractable pump failure
- Intractable ventricular arrhythmias

Arrhythmias

Nearly all patients with acute MI have arrhythmias. In many cases, it is mild and of no haemodynamic significance.

Common arrhythmias seen in acute MI are:

- Ventricular fibrillation*: This is a major cause of death within one hour of developing MI
- Ventricular tachycardia
- Accelerated idioventricular rhythm
- Ventricular ectopics
- Atrial fibrillation*: Common and frequently transient. May cause a rapid ventricular rate and hypotension
- Atrial tachycardia
- Sinus bradycardia*: Should be treated if there is associated hypotension
- Heart block*: Following inferior wall MI is often temporary and may resolve without treatment, but is more serious leading sometimes to asystole when occurring following anterior wall MI.



Treatment of Arrhythmias

- Sinus bradycardia*: No treatment if the patient is stable. If heart rate is below 50/min. and patient symptomatic, inj. atropine (0.6–1.0 mg) IV may be given.
- Sinus tachycardia*: The underlying aetiology of tachycardia is detected (infection, anxiety, pericarditis, hypovolaemia, left ventricular failure, pain) and treated appropriately.
- Atrial fibrillation*: May be treated with digoxin, calcium channel blockers or β -blockers which reduce the ventricular rate. If AF is resistant to these drugs and patient is symptomatic, cardioversion may be attempted.

Digoxin is indicated in AF with heart failure and calcium channel blockers (verapamil) and β -blockers are indicated in AF without heart failure.
- Atrial flutter*: Cardioversion is the preferred treatment.
- Supraventricular tachycardia*: Sustained SVT should be treated with intravenous verapamil or adenosine. If it does not revert to sinus rhythm cardioversion may be attempted if concomitant failure is present.
- Junctional tachycardia*: Rapid and sustained junctional tachycardia should be treated in a manner similar to that for SVT.

7. *Pre-mature ventricular contractions and ventricular tachycardia*: These may be treated by giving inj. Lidocaine IV in a dose of 1–4 mg/kg body weight bolus, followed by an infusion at 2–4 mg/min. Other drugs which may be used are procainamide, amiodarone, metoprolol, tocainide, quinidine or mexiletine. If ventricular tachycardia is not controlled by these drugs, then a synchronised DC shock should be administered.

VPC:

K⁺ 4.5 mEq and Mg 2.5 mEq – β -blocker is indicated.

The criteria for treating premature ventricular contractions has been discussed in the chapter on ECG, under significant ventricular extrasystoles.

8. *Ventricular fibrillation*: Immediate unsynchronised cardioversion is the treatment of choice. Drugs that may be tried are lidocaine or bretylium.

Non-pharmacologic therapy for VT/VF:

- It includes automatic ICD and catheter ablation.
- ICDs provide automatic recognition and treatment of ventricular arrhythmias.
- ICD is very useful in primary prevention of sudden cardiac death (SCD).

Sudden cardiac death is common in hypertrophic cardiomyopathy, congenital long QT syndrome, family history of SCD and CAD with low EF.

- ICD is useful in most patients with LVEF of < 35% for more than 3 months.
 - ICD implantation is essential to protect against SCD prior to cardiac transplantation (Fig. 3.141).
9. *Heart blocks*: First degree heart block, mobitz type I block and asymptomatic complete heart block need not be treated.

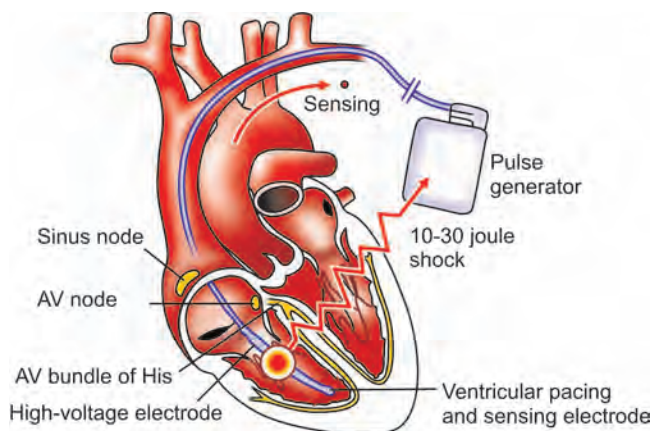

Fig. 3.141: Implantable cardiac defibrillator

Mobitz type II and symptomatic complete heart block must be treated with the use of a permanent pacemaker.

Pacemakers: Pacemakers supply electrical initiation to contraction. They may dramatically benefit even a very old patient. The pacemaker lies subcutaneously where it may be programmed through the skin as needs change, e.g. for different rates. They last for 7–15 years.

Indications for Temporary Pacemaker

1. Symptomatic bradycardia, uncontrolled by drugs.
2. Suppression of drug-resistant VT and SVT.
3. Acute conduction disturbances:
 - a. After acute anterior MI, prophylactic pacing is required in:
 - i. Second or third degree AV block;
 - ii. Bi- or tri-fascicular block.
 - b. After acute inferior MI, if patient is symptomatic.

Indications for Permanent Pacemaker

1. 2° (Mobitz type II) and 3° heart block.
2. Symptomatic bradycardias (e.g. sick sinus syndrome).
3. Occasionally useful in suppressing resistant tachyarrhythmias.
4. Persistent bi-fascicular block after MI (this remains controversial).

Post Infarct Angina

This may occur in 50% of patients having residual stenosis in the infarct related vessel. This may be treated by controlling the concomitant failure or by IV nitroglycerine, if there is no contraindication to its use.

Coronary angiography and mechanical revascularisation can be done.

Myocardial Stunning

It is a temporary and reversible post-ischaemic systolic and/or diastolic ventricular dysfunction in which the myocardium is still viable. This condition may be reversed by thrombolytic therapy, PTCA or CABG.

Pericarditis

This may occur in the early or late stage of MI.

In the early stage, it is particularly common on the second or third day after MI.

In the late stage, occurring weeks or even months after MI, it is due to probably an autoimmune reaction to the necrotic myocardium. It is known as 'postmyocardial infarct syndrome' or *Dressler's syndrome* and is



characterised by persistent fever, pericarditis and pleurisy.

Treatment: Anticoagulants are contraindicated.

Pericarditis occurring immediately after MI is treated by using NSAIDs. Steroids are contraindicated, as aneurysm formation or cardiac rupture may occur due to poor healing of the infarcted area.

Dressler's syndrome is treated with NSAIDs initially, and if there is no response, then steroids may be used.



Mechanical Complications

- Papillary muscle damage, with onset of severe MR and acute pulmonary oedema. A loud PSM and S_3 may be heard.
- Rupture of the interventricular septum leading to a left to right shunt through a VSD. A loud PSM may be heard. In contrast to MR, however, an acquired VSD causes right heart failure rather than acute pulmonary oedema.
- Rupture of the ventricle leading to cardiac tamponade.

Cardiac rupture is common in females, in the first week after MI, during the first infarct, in the elderly, in the absence of LVH, when associated with hypertension and in patients receiving NSAIDs and steroids.

There is electromechanical dissociation (electrical activity persists with pump failure and a non-recordable pulse and BP).

Thromboembolism

Thrombosis forms on the endocardial surface of freshly infarcted myocardium and may lead to systemic embolism.

Deep vein thrombosis may lead to pulmonary embolism.

Treatment: Prevention of thrombus formation is done by use of anticoagulants.

Ventricular Aneurysm

Predisposing Factors

- Decreased left ventricular ejection fraction
- Anterior wall myocardial infarction
- Congestive cardiac failure
- Large regional wall motion abnormality

A LV aneurysm (Fig. 3.142) may develop causing cardiac failure, ventricular arrhythmias, mural thrombus and systemic embolism. Its occurrence is particularly common when there is persistent occlusion of the infarct

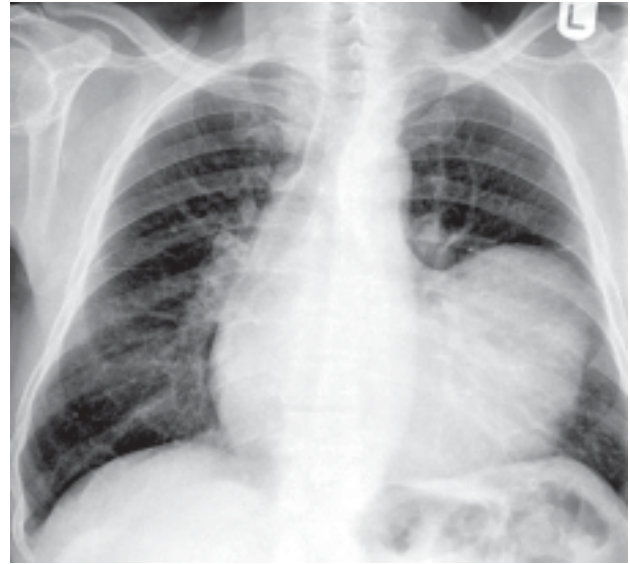

Fig. 3.142: LV aneurysm

related vessel and should be suspected when there is persistent ST elevation in the ECG.

True LV aneurysm must be differentiated from false LV aneurysm, occurring due to cardiac rupture and subsequent formation of an organised haematoma covered by the pericardium. False LV aneurysms occur due to cardiac rupture following MI, due to injury or due to previous cardiac surgery.

True LV aneurysm can be differentiated from the false LV aneurysm, by use of 2D Echo, where, false LV aneurysm has a narrow orifice, and true LV aneurysm has a wide orifice, connecting it to the heart.

False LV aneurysm must be surgically corrected even in the absence of symptoms or signs. True LV aneurysm may be surgically corrected if there is associated refractory failure or systemic embolisation in spite of adequate anticoagulation.

Right Ventricular Infarction

In approximately 30% of patients with Q-wave inferior wall MI, there is associated right ventricular infarction. Rarely, it can occur with anterior wall MI.



Clinical Features

Hypotension
Pulsus paradoxus
Raised JVP
Kussmaul's sign
Clear lungs
RV S_3 and S_4



Comparison of Anterior and Inferior Wall Myocardial Infarction

Features	Anterior MI	Inferior MI
1. Extent of necrosis	Large	Small
2. Extent of coronary atherosclerosis	Small	Large
3. Complications		
a. Ventricular septal rupture	Apical, easily repaired	Basal, difficult to repair
b. Aneurysm	Common	Uncommon
c. Free wall rupture	Uncommon	Rare
d. Mural thrombus	Common	Uncommon
e. Heart blocks	Uncommon	Common
f. Bundle branch blocks	Common	Uncommon
4. Prognosis	Worse than that of inferior MI	Better than that of anterior MI
5. Diagnosis		
a. Symptoms	Gastrointestinal symptoms unusual	Gastrointestinal symptoms (nausea, vomiting, hiccough) common
b. Physical examination	Tachycardia; hypotension uncommon. Jugular venous distention less common than with inferior MI. 50% have S ₃	Bradycardia; hypotension common. Jugular venous distention common. 20% have S ₃
c. ECG	Features of anterior wall MI	Features of inferior wall MI
d. Echocardiogram	Abnormal left ventricular wall motion is anterior in location. No abnormal right ventricular wall motion	Abnormal left ventricular wall motion is inferior in location. Right ventricular abnormal wall motion present in approximately one-third of patients.

TR murmur

Enlarged, tender liver.



Treatment

- Diuretics are contraindicated.
- IV fluids are given to counteract the hypotension.



Management

1. Bed-rest
2. Nasal O₂
3. Morphine given in an intravenous form (< 1 mg per minute) to a maximum dose of 10–15 mg. It acts as a pulmonary venodilator and also as an analgesic to alleviate anxiety
4. Nitrates may be given sublingually for rapid action of relief of pain by coronary vasodilation. It also helps to reduce the preload of the heart, being a predominant venodilator. If pain persists after administration of sublingual nitrates, IV infusion of nitroglycerine may be given, provided the systolic BP is maintained above 100 mm Hg
5. Aspirin is given orally in the dose ranging from 100 to 300 mg
6. Thrombolytic therapy (Streptokinase, Urokinase, Tissue plasminogen activator) may be given and is particularly useful if given within 6 hrs of onset of

symptoms, but may be given upto 12 hrs after onset of symptoms.

Ideal—door to needle time 30 min.

Thrombolytic agents for Myocardial Infarction

Agents with fibrin specificity:

1. Alteplase (rt-PA) 15 mg IV bolus followed by 0.75 mg/kg IV infusion (upto 50 mg) over 30 minutes then 0.5 mg/kg (upto 35 mg) by IV infusion over 60 minutes (maximum dose 100 mg IV over 90 minutes)
2. Reteplase (r-PA) 10 mg IV bolus over 2 minutes followed by another 10 mg IV bolus after 30 minutes.
3. Tenecteplase (TNK-tPA) 0.5 mg/kg IV bolus (<60 kg-30 mg, 61-70 kg-35 mg, 71-80 kg-40 mg, 81-90 kg- 45 mg, >90 kg-50 mg)

Agents without fibrin specificity:

1. Streptokinase – 1.5 million units IV infusion over 60 minutes
2. Urokinase

Because of the development of antibodies, patients who were previously treated with streptokinase should be given an alternate thrombolytic agent.

Contraindications for Thrombolytic Therapy

Absolute contraindications:

- Active bleeding
- Defective haemostasis



Commonly used Drugs in CAD–ACS/MI

Drugs	Clinical condition	Contraindication	Dosage
Nitrates	Angina/equivalents	Hypotension	Infusion – 5-10 µg/min Titrate upto 75-100 µg/min or Topical/oral/buccal
Beta blockers	Unstable angina ACS/MI/ Secondary prevention, Angina inspite of nitrates	Heart rate < 60/min AV – block, ShockBP < 90 mm Hg COPD, CCF	Metoprolol 5 mg IV Repeat every 5 min upto 15 mg and then oral 25-50 mg/bid Esmolol 0.1 mg/kg/min/IV
Morphine sulphate	Persistent pain	Hypotension, Respiratory depression/confusion	2-5 mg IV Repeat 5-30 min as needed
ACE inhibitors	LV-dysfunction EF < 40%, H. failure	Hypotension Renal insufficiency	Captopril/Enalapril Ramipril (avoid IV)
Warfarin	Atrial fibrillation LV-dysfunction thrombus/emboli	Bleeding manifestations	5-10 mg to maintain INR of 2-3
Calcium channel blockers	Variant angina Recurrent ischaemia	Pulmonary oedema LV dysfunction	Avoid short acting nifedipine

Anti-ischaemic Drugs—Mechanisms of Action

Action	Nitrates	β-blockers	Ca-blockers
Decreased myocardial demand	++	+++	+ to ++
Increased coronary blood supply	+++	0 to +	++ to +++
Prevent coronary spasm or vasoconstriction	++	0	++ to +++
Left ventricular function	Improves	0	0
Other actions	Antiplatelet action and Normalises endothelial function	Electrical stabilisation and antiarrhythmic and antihypertensive	Antihypertensive

Recent major trauma
Surgical procedures < 10 days
Invasive procedures < 10 days
Neurosurgical procedure < 2 months
GI/genito-urinary bleeding < 6 months
Stroke/TIA < 12 months
Prolonged CPR > 10 minutes
H/O CNS tumour, aneurysm, AV malformation
Active peptic ulcer
Aortic dissection
Acute pericarditis
Active inflammatory bowel disease
Active cavitory lung disease
Pregnancy

Relative contraindications:

Systolic BP > 180 mm Hg
Diastolic BP >110 mm Hg
Bacterial endocarditis
Haemorrhagic diabetic retinopathy

H/O intraocular bleeding
Chronic warfarin therapy
Severe renal or liver disease
Severe menstrual bleeding

Beta blockers can be used in LV dysfunction with low ejection fraction whereas calcium channel blockers should not be used. ACE inhibitor is the ideal choice in the presence of LV dysfunction and cardiac failure with normal renal function.

- Heparin may be given in a dose of 5000 U, 12 hourly, subcutaneously, as prophylaxis against development of deep vein thrombosis and 12,500 U, 12 hourly, subcutaneously, as prophylaxis against development of mural thrombus or extension of the coronary thrombus, for a period of 7–10 days
- β-blockers are started immediately, or after two weeks and given for a minimum duration of two years, if there is no contraindication for their use,



as these agents (atenolol, metoprolol, propranolol) help in reducing morbidity and mortality significantly. β -blockers can be given even if the ejection fraction as determined by Echo is $< 40\%$, but calcium channel blockers must be avoided

9. ACE inhibitors help in cardiac remodelling and reduce morbidity and mortality
10. Treatment of the associated complications as and when they arise
11. Advice patient to stop smoking
12. Control of associated risk factors (systemic hypertension, diabetes mellitus, hyperlipidaemia)
13. Rehabilitation
If the patient is stable and no complications:
Sit in a chair – 2nd day
Walk to toilet – 3rd day
Return home – 7th day
Back to work – 6th week
Driving (LMV) – 6 weeks
Intercourse – 8 weeks
Air travel – 8 weeks
14. Surgery (coronary angioplasty, coronary artery bypass grafting) if medical management fails or if there is severe compromise of coronary circulation.
15. *Drug eluting stents* – Many drugs have been considered for drug eluting stents. The main drugs used are paclitaxel (Taxol), sirolimus and their derivatives (tacrolimus, everolimus). These stents have lower rates of restenosis. They act by inhibiting neointimal hyperplasia (antiproliferative action).
16. *Assessment of ischaemic burden*: A sub-maximal stress testing is done at the end of first week and a maximal exercise stress test at the end of 6 weeks. Stress testing aids in assessing the patient's ischaemic burden and planning further line of management.
17. *Alternate therapies*:
 - Transmyocardial laser revascularisation by percutaneous technique
 - Enhanced external counterpulsation to decrease the frequency of angina
 - Spinal cord stimulation (C7-T1 – epidural space electrode) to improve anginal symptoms

Myocarditis

Myocarditis is the inflammation of myocardium.



Causes

Infective

Bacterial

Staphylococcus aureus endocarditis

Diphtheria

Lyme disease (tick borne spirochete)

Salmonella

Tuberculosis

β haemolytic streptococci

Meningococci

Leptospirosis

Viral
Coxsackie B virus

HIV

Influenza

Poliomyelitis

Viral hepatitis C and adeno virus

Cytomegalo virus

Epstein-Barr virus

Fungal
Candida

Cryptococci

Blastomyces

Aspergillus

Rickettsia
R. typhi (typhus)

R. tsutsugamushi (scrub typhus)

Chlamydia
C. psittaci

Protozoal
Trypanosomiasis

Toxoplasmosis

Hypersensitivity Acute rheumatic fever
states

Physical agents Radiation, heat stroke

Chemicals Cobalt, antimony, arsenic

Drugs Phenothiazines, tricyclic antidepressants, emetine, penicillin, methyl dopa

Unknown Fiedler's giant cell myocarditis.

Myocarditis may progress to dilated cardiomyopathy.



Clinical Features

Fatigue, angina, dyspnoea, inappropriate or disproportionate tachycardia, heart failure.

On Examination

Muffled S₁, S₃, MR murmur, pericardial friction rub.

ECG

Disproportionate tachycardia; transient ST-T changes; various conduction defects can occur including atrial or ventricular ectopics.

Contrast MRI

It reveals contrast enhancement.



Diagnosis and Management

By clinical features and identification of causative organisms



- i. No strenuous activity (to prevent fatal ventricular arrhythmias)
- ii. Management of arrhythmias
- iii. Specific antimicrobial therapy or antitoxin
- iv. Avoid NSAIDs as they may worsen myocardial damage
- v. Effectiveness of steroid therapy is controversial.

Cardiomyopathies

Cardiomyopathies are primary disorders of heart muscle when cause is not identified. They are of three types:

Dilated (Congestive) Cardiomyopathy (Fig. 3.143)

There is impaired ventricular contraction leading to progressive left sided and later right sided failure. There may be functional MR or TR.



Clinical Features

ECG: Non-specific; ST-T wave abnormalities may be seen.

Echo: Global hypokinesia; dilated heart (LV dilatation).

Cardiac catheterisation: LV dilatation and dysfunction; increased left and right sided filling pressures; decreased cardiac output.

Radionuclide studies: LV dilatation and dysfunction.



Differential Diagnosis

- Ischaemic heart disease
- Alcoholic heart disease.



Fig. 3.143: Dilated cardiomyopathy



Management

- Antifailure measures
- Consider heart transplant
- Anticoagulants
- Avoid NSAIDs, alcohol, and calcium channel blockers.

Restrictive (Obliterative) Cardiomyopathy

There is impairment of ventricular filling because they are stiff. This leads to high atrial pressure, hypertrophy and dilatation of atria and atrial fibrillation.



Differential Diagnosis

- Endomyocardial fibrosis (It most commonly occurs in children and young adults. This is characterised by fibrous endocardial lesions of the inflow portion of both the right and left ventricles often involving AV valves causing regurgitation. Apex may be obliterated by a mass of thrombus and fibrous tissue. EMF frequently causes CCF. Treatment is by surgical excision of fibrotic endocardium and replacement of AV valves)
- Constrictive pericarditis
- Eosinophilic heart muscle disease
- Amyloidosis.



Clinical Features

X-ray: Mild cardiomegaly.

ECG: Low voltage; conduction defects.

Doppler echo: Abnormal diastolic function; symmetrical thickened LV walls and a normal or slightly decreased systolic function.

Cardiac catheterisation: Same findings as above plus elevated left and right sided filling pressures.

Radionuclide studies: Normal or mildly decreased systolic function.

CT and MRI: Detect thickened pericardium in constrictive pericarditis.

Endomyocardial biopsy: Interstitial infiltration or fibrosis.

Hypertrophic Obstructive Cardiomyopathy (HOCM) (Fig. 3.144)

It can be familial (autosomal dominant) or sporadic.

In familial cases, abnormality of beta myosin heavy chain gene on chromosome 14 is found. There is asym-



Fig. 3.144: Hypertrophic obstructive cardiomyopathy mid ventricular type

metrical, elaborate ventricular hypertrophy of septum or apex with malalignment of myocardial fibres. The stiff, non-compliant ventricle impedes diastolic filling.

Asymmetric hypertrophy of septum (ASH) may also cause dynamic LV outflow tract obstruction and MR due to systolic anterior motion of anterior leaflet of mitral valve (SAM).

Symptoms

Dyspnoea, angina, syncope, palpitation, sudden death.

Signs

Jerky pulse, double or triple apex, S_3 , S_4 , late systolic murmur (outflow obstruction + MR) AF common when associated with MVP.



Differential Diagnosis

ECG: Shows LVH and LBBB; deep broad Q-waves and arrhythmias (SVT, AF, VT) seen.

X-ray: Mild to moderate cardiac enlargement.

Echo: Asymmetrical septal hypertrophy (septum: Left ventricular posterior free wall is 1.3 or more : 1) and SAM.

Cardiac catheterisation: Small, banana like or spade-shaped LV cavity; thickened papillary muscle and trabeculae; Cavity obliteration in systole; Dynamic LV outflow obstruction.

Radionuclide studies: Vigorous systolic function and asymmetric septal hypertrophy.

Contrast MRI: It is superior to echocardiogram in providing accurate measurement of regional hypertrophy and fibrosis.



Management

- Beta blocker for angina
- Amiodarone for arrhythmia
- Septal myectomy or myotomy
- In chronic AF, anticoagulation
- Avoid diuretics, digitalis, β -agonists, nitrates, vasodilators like nifedipine
- IE prophylaxis when associated with MR
- Alcohol ablation treatment
- Insertion of an implantable cardioverter defibrillator in high risk patients
- Verapamil, diltiazem, disopyramide improve the symptoms of HCM by augmenting the diastolic ventricular filling
- IE prophylaxis when there is prior H/O IE.

Sudden Death is Common in those who have

- i. Ventricular tachycardia (non-sustained)
- ii. Family history of sudden death
- iii. History of syncope
- iv. Previous history of resuscitation
- v. Marked ventricular hypertrophy
- vi. Abnormal BP response to exercise
- vii. Genetic mutations at risk.

Primary Cardiomyopathies

1. Idiopathic
2. Familial
3. Eosinophilic endomyocardial disease
4. Endomyocardial fibrosis.

Secondary Cardiomyopathies



Causes

Myocarditis

Bacterial, fungal, viral, protozoal, metazoal, rickettsial.

Metabolic

- Hyper and hypothyroidism
- Hyper and hypokalaemia
- Nutritional deficiency—thiamine, protein
- Hemochromatosis.



Familial Storage Disease

- Glycogen storage disease
- Mucopolysaccharidoses.

Connective Tissue Disorders

- SLE
- Polyarteritis nodosa
- Rheumatoid arthritis
- Progressive systemic sclerosis
- Dermatomyositis.

Infiltrations and Granulomas

- Amyloidosis
- Sarcoidosis
- Malignancy (leukaemias, lymphomas, malignant melanoma, carcinoma of lung or breast).

Neuromuscular

- Muscular dystrophy
- Myotonic dystrophy
- Friedreich's ataxia
- Refsum's disease.

Sensitivity and Toxic Reactions

- Alcohol
- Radiation

- Drugs (lithium, cyclophosphamide, doxorubicin, daunorubicin)

Peripartum Cardiomyopathy

Aetiology is unclear. Symptoms and signs are similar to other forms of dilated cardiomyopathy. It is common in multiparous women of >30 years age.

Criteria for Diagnosis

1. Development of cardiac failure during last trimester of pregnancy or within 6 months of delivery.
2. Absence of determinable cause for cardiac failure
3. Demonstrable impairment in LV systolic function. Management is similar as for other forms of DCM. Selective use of vasodilators like hydralazine and avoid ACE inhibitors during pregnancy. Anticoagulation is necessary. Avoid future pregnancy as the condition can recur.

Endocardial Fibroelastosis

This is characterised by elastic and fibrous thickening of the endocardium. It commonly involves LV and LA. RV and RA are less frequently involved; It is one of the cardiac disorders causing CCF in infancy. Endocardium has a smooth, glistening white surface consisting of dense layers of elastic fibres.

Differentiating Features of Constrictive Pericarditis, Restrictive Cardiomyopathy and Right Ventricular Myocardial Infarction

Features	Constrictive Pericarditis	Restrictive Cardiomyopathy	RV Infarct	Cardiac Tamponade
1. Symptoms	Of underlying disease	Of underlying disease	Of acute MI	Dyspnoea and tightness of chest
2. JVP				
(a) Prominent 'y' descent	Present	Absent	Absent	Absent
(b) Prominent 'x' descent	Absent	Present	Absent	Present
(c) Kussmaul's sign	Present	Present or absent	Absent	Absent
3. S ₃	Absent	Absent	May be present	Absent
4. Pericardial knock	Present	Absent	Absent	Absent
5. ECG low voltage complexes	May be present	May be present	Absent	May be present
6. Echocardiography				
(a) Thickened pericardium	Present	Absent	Absent	Absent
(b) RV size	Usually normal	Usually normal	Enlarged	Usually small
(c) Myocardial thickness	Normal	Usually increased	Normal	Normal
7. Cardiac catheterisation				
(a) RA/LA pressure	Equal	LA > RA	RA > LA	Equal
(b) Variation of RA pressure with respiration	Absent	Present	Present	
(c) Ventricular diastolic pressures	Equal in RV and LV	LV > RV by more than 5 mm Hg.	RV > LV	
(d) PCWP	< 18 mm Hg.	> 18 mm Hg.	Low	
(e) Pulmonary artery pressure	< 50 mm Hg.	> 50 mm Hg.	Low	
8. Biopsy of myocardium	Not helpful	May be helpful	Not helpful	No



Patients have features suggestive of myocardial failure (dyspnoea, orthopnoea and cough); They may have holosystolic murmur of MR. Chest X-ray shows cardiomegaly; ECG shows LVH; Echo shows LV dilatation with poor contractility. Death usually occurs within 1st year of life. Patients can be treated symptomatically for CCF and valve replacement may be done for MR.

Pericarditis

Acute	< 6 weeks
Subacute	6 weeks–6 months
Chronic	> 6 months

Aetiologic Classification (Figs 3.145 to 3.148)

Infectious Pericarditis

1. Viral
2. Pyogenic
3. Tuberculous
4. Mycotic
5. Syphilitic.

Non-infectious Pericarditis

1. Acute MI
2. Uraemia
3. Neoplasia (primaries and secondaries)
4. Myxoedema
5. Chylopericardium
6. Trauma
7. Post irradiation
8. Infectious mononucleosis

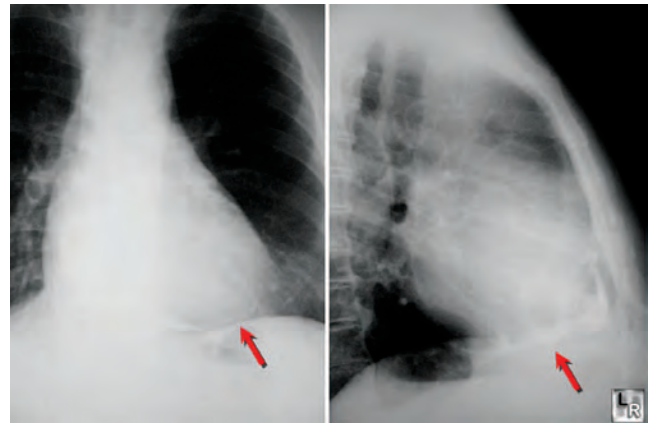

Fig. 3.146: Thickened and calcified pericardium

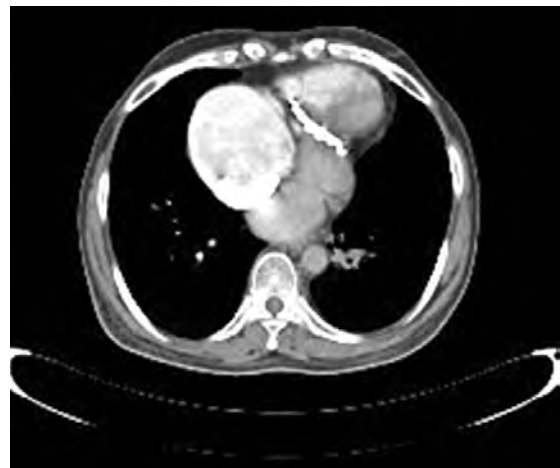

Fig. 3.147: Constrictive pericarditis. Calcified pericardium (6 mm) leading to gross dilatation of RA and mild dilatation of LA with compression of RV and LV



Fig. 3.145: Pericardial effusion



Fig. 3.148: Pericardial effusion



9. Aortic aneurysm with leak into pericardium
10. Familial pericarditis
11. Sarcoidosis
12. Idiopathic
13. Familial mediterranean fever.

Pericarditis Related to Hypersensitivity or Autoimmunity

1. Rheumatic fever
2. Collagen vascular disorders
 - a. SLE
 - b. Rheumatoid arthritis
 - c. Scleroderma
3. Drug induced
 - a. Procainamide
 - b. Hydralazine
 - c. INH
 - d. Cromolyn
 - e. Minoxidil
4. Post-cardiac injury
 - a. After MI (Dressler's syndrome)
 - b. Post-pericardiectomy



Management

- Aspirin or indomethacin are useful; When the response is not satisfactory, steroids can be used.
- Anticoagulants are contraindicated (haemopericardium or tamponade may occur).
- Steroids are best avoided in pericarditis following MI because of myocardial aneurysm formation and rupture.
- In chronic pericarditis, pericardiectomy should be considered.

Cardiac Tamponade

The accumulation of fluid in the pericardium sufficient to cause serious obstruction to the inflow of blood to the ventricles results in cardiac tamponade.



Causes

1. Neoplastic disease
2. Idiopathic pericarditis
3. Uraemia
4. Tuberculosis
5. Cardiac surgery
6. Trauma
7. Haemopericardium



Clinical Features

The symptoms depend upon the rapidity of accumulation of fluid. As small as 200 ml can produce the critical state when fluid develops rapidly or more than 2 litres in slowly developing effusions. Patient presents with severe dyspnoea, chest tightness and dizziness.

In striking contrast to elevated venous pressure (prominent \times descent), arterial hypotension, and pulsus paradoxus, cardiac pulsation often are impalpable (Beck's triad). Kussmaul's sign, pericardial knock and 3rd heart sound are rare.

Beck's Triad

1. Hypotension
2. Raised JVP
3. Muffled or absent heart sounds.

ECG

Low voltage complexes with or without electrical alternans.

Echocardiogram

Diastolic collapse of right ventricular free wall and right atrium is the characteristic feature of cardiac tamponade.



Management

If manifestations of tamponade appears, pericardiocentesis must be carried out at once and is life saving. A small catheter advanced over the needle inserted into the pericardial cavity may be left in place to allow draining of the pericardial space if fluid reaccumulates. Surgical drainage through a limited thoracotomy may be required in recurrent tamponade or when tissue diagnosis is needed.

If pericardial drainage is delayed, IV saline is given to maintain adequate ventricular filling along with parenteral inotropic support to stabilise the patient. Do not use diuretics, nitrates or any other pre-load reducing agents.

Cardiac Arrest—Causes

Anatomical/Mechanical

Coronary artery disease	Atherosclerosis
	Ischaemic heart disease

Anomalous left coronary artery from pulmonary artery (ALCAPA).



Kawasaki disease

Myocardial disorders *Primary*Hypertrophic obstructive-
cardiomyopathy*Secondary*Dilated cardiomyopathy
Infiltrative cardiomyopathy

Myocarditis

Valvular heart
disease

Aortic stenosis,

Pulmonary stenosis

Mitral valve prolapse syndrome

Cardiac failure

Cardiac shock

Electrical

- Wolff-Parkinson-White syndrome
- Romano-Ward syndrome (Long QT_c)
- Jervell-Lange-Nielsen syndrome (Long QT_c)
- Electric shock.

Physiological

Metabolic

Hypoxia

Hypercapnia

Hypocalcaemia

Hypomagnesaemia

Hypokalaemia

Hyperkalaemia.

Toxins

Antiarrhythmics

Digitalis

Cocaine

Adrenaline.

Cardiopulmonary Resuscitation (Basic Life Support)

Cardiopulmonary resuscitation (CPR) was developed to rescue patients with acute circulatory or respiratory failure or both.

The **ABCs** of basic life support are:

- A**irway
- B**reathing
- C**irculation.

and are essential for successful resuscitative efforts.

When one encounters an unconscious patient, the following procedures are recommended:

1. Determine responsiveness by gently shaking the patient. *Do not shake the head or neck unless trauma to this area has been excluded*
2. Position the patient on a firm, flat surface

3. Assess patency of airway and presence of respiration. Place the palm of one hand on the patient's forehead and apply firm pressure to tilt the head backward. At the same time, place the index and middle fingers of the other hand under the chin and displace the mandible anteriorly. This will raise the tongue away from the posterior pharynx. If a neck injury is suspected, the neck tilt should be avoided and the modified jaw thrust, by grasping the angles of the mandible with the fingers of both hands and moving the mandible anteriorly is done. With the airway thus made patent, the presence of spontaneous respiration is looked for.
4. *Assisted ventilation* is started when there is no spontaneous respiration. Gently pinch the nose closed with the index finger and thumb of the hand kept on the forehead. Make a tight seal over the patient's mouth and ventilate twice with slow, full breaths (1–1.5 seconds each). A two second pause should be interspersed between breaths. Alternatively, an Ambu bag may be used for ventilation.

Indicators of adequate ventilation are the rise and fall of the chest and detection of escaping air during expiration.

5. *Palpate the carotid pulse* for at least 5 seconds. If a carotid pulse is palpable, assisted ventilation should be continued at a rate of 12 breaths per minute. If carotid pulse is not palpable, then cardiac resuscitation should be started.
6. *Cardiac resuscitation* is started by placing the patient on a firm surface. An initial blow to the chest over the sternum is delivered. Chest compressions are performed by placing the heel of one hand on the back of the other and placing it 1 inch above the xiphoid process of the sternum, with the shoulders directly above the hands and the elbows in a locked position. With the heel of the hand, the sternum is compressed 3–5 cm., the thrust being applied straight down towards the spine.

Basic life support should be stopped for 5 seconds at the end of the first minute and every 2–3 minutes thereafter to determine whether the patient has resumed spontaneous breathing or circulation. The procedure should be continued till advanced cardiac life support is made available for revival.

CPR should be continued for a minimum period of 30 minutes. If, however, the pupils become dilated and fixed and the patient does not regain consciousness, CPR may be discontinued.

CPR need not be done in end organ failure or multisystem failure.



Cardioversion (DC Shock)

Cardioversion or DC shock is a safe means of terminating various tachyarrhythmias and restoring sinus rhythm.

Cardioversion is only effective for re-entrant arrhythmias, including atrial and ventricular fibrillation, but not for those caused by abnormal automaticity.

Indication for DC Shock

1. *Atrial fibrillation* is one of the most common indications for cardioversion. A minimum of 100 joules is required. Patients are unlikely to maintain sinus rhythm if atrial fibrillation is of longstanding duration or the echocardiographically determined left atrial dimension exceeds 4.5 cm. Cardioversion is more likely to be complicated by systemic emboli in patients with atrial fibrillation of more than 3 days' duration and hence anticoagulants should be administered for up to 3–6 weeks before the procedure, and for 1 week after the procedure.
2. *Atrial flutter* is one of the easiest rhythms to convert to sinus rhythm. Cardioversion frequently requires less than 50 joules.
3. *Re-entrant SVTs* require 25–100 joules for cardioversion.
4. *Ventricular tachycardia* requires synchronised cardioversion of 20–50 joules to be applied. If however the pulse and blood pressure are not recordable, 200 joules, followed by 360 joules (if no response) should be delivered.
5. *Ventricular fibrillation* requires repeated unsynchronised cardioversion, starting with 200 joules, followed by 3–4 applications of 360 joules.

If there is no response, then the following manoeuvres may be carried out:

CPR—Establish IV access—Epinephrine 1:10,000, 0.5–1 mg. IV stat—Intubation—DC shock of 360 joules—Lidocaine 1 mg/kg. IV stat—DC shock of 360 joules—Bretylium 5 mg/kg. IV stat—DC shock of 360 joules—Bretylium 10 mg/kg. IV stat—DC shock of 360 joules—Repeat Lidocaine and Bretylium—DC shock of 360 joules.

Sodium bicarbonate in a dose of 0.5 mEq/kg body weight may be administered intermittently every 10–15 minutes to counteract the developing acidosis.

Immediate cardioversion is mandatory if the arrhythmia causes angina, hypotension or heart failure.

Contraindications to Cardioversion

1. *Digitalis toxicity*: Elective cardioversion should not be performed in the presence of potentially toxic levels of digoxin. If cardioversion is necessary, then prophylactic lidocaine therapy should be given and cardioversion should begin at low energy levels.
2. Repetitive, short-lived tachycardias.
3. Multifocal atrial tachycardia or other automatic arrhythmias.
4. Patients with sick sinus syndrome, complete AV block or on β -blockers (as cardioversion may potentiate severe bradycardia).
5. Patients with supraventricular arrhythmias in hyperthyroidism should be made euthyroid before elective cardioversion.
6. Patients with AF secondary to mitral stenosis must have the underlying problem (MS) corrected before attempting to revert AF to sinus rhythm.
7. In patients with pacemaker (as pacemaker may be damaged).
8. Tachyarrhythmias developing immediately after cardiac surgery (as they cannot maintain sinus rhythm).
9. AF of long-standing duration (> 1 year duration).

Cardiac Transplantation

Cardiac transplantation is the therapy of choice for end stage heart disease, who are unlikely to survive for the next 6–12 months as evidenced by a decrease in ejection fraction of less than 20% or presence of serious ventricular arrhythmias.

Optimal candidates for transplantation are those who do not show evidence of end stage organ damage from cardiac failure and do not suffer from other systemic illnesses like collagen vascular disease or HIV. Long-standing pulmonary hypertension, recurrent pulmonary emboli or pulmonary infarction carries a high risk of intraoperative death.

Patients who are dopamine/dobutamine dependent to maintain an adequate cardiac output are those who get the highest priority for a donor heart.

A suitable donor is obtained by doing ABO matching and lymphocyte cross matching. He should also test negative for cytomegalovirus infection.

The donor heart is removed, except for posterior wall of RA, SVC and IVC. The LA along with the pulmonary veins are also left *in situ*. The donor heart is then sutured to the posterior wall of the two atria of the recipient's heart, the rest of the heart having been incised and removed.



Rejection of cardiac transplant is characterised by perivascular infiltration of killer T-lymphocytes, which may later migrate into the myocardium. This can be assessed by repeated percutaneous transvenous RV endomyocardial biopsies via the right internal jugular vein, every 3 months. Prolongation of isovolumetric relaxation time by echo may also provide an early clue to rejection.

Immunosuppressive therapy is given with cyclosporine, azathioprine and prednisolone. There is an increased risk of development of malignancy due to this.

The donor sinus node controls the rate of the transplanted heart. The controlling sinus node has no innervation by the autonomic nervous system and maintains a constant heart rate of 100–110 beats per minute.

The ECG taken after transplantation shows two P-waves (one from the recipient's SA node and the other from the donor's SA node). The P-wave from the recipient's SA node is dissociated from the QRS complexes as the impulse does not cross the suture line,

whereas the P-wave arising from the donor SA node precedes the QRS complex.

Chronic rejection may occur in the form of accelerated atherosclerosis of the coronary arteries, affecting both the proximal and distal vessels and is the most important cause of death. Angina is rare, as the transplanted heart is devoid of autonomic innervation.

Contraindications to Cardiac Transplantation

- Age more than 65 years
- Active infection
- DM with end-organ disease
- Pulmonary function < 60% predicted or COPD
- Serum creatinine > 2 mg/dL or
- Creatinine clearance < 40 mL/minute
- Serum bilirubin > 2 mg/dL
- Elevated transaminases- > 2 × normal value
- Pulmonary artery systolic pressure > 60 mm of Hg
- Transpulmonary gradient > 15 mm of Hg (TPG = Mean pulmonary artery pressure minus capillary wedge pressure)



Chapter 4 Respiratory System

SYMPTOMS

COUGH
(dry/productive)

SPUTUM

HAEMOPTYSIS

WHEEZING

CHEST PAIN

BREATHLESSNESS

SIGNS

Physique

Pyrexia

Dyspnoea/tachypnoea

Intercostal recession

Breathing
(abdominal/thoracic)

Cyanosis

Action of accessory muscles

Clubbing

Lymph nodes

Tracheal position

Shape of chest

Chest movements

Apical impulse

Breath sounds

Added sounds

Evidence of PHT

Signs of heart failure

Hoarse voice

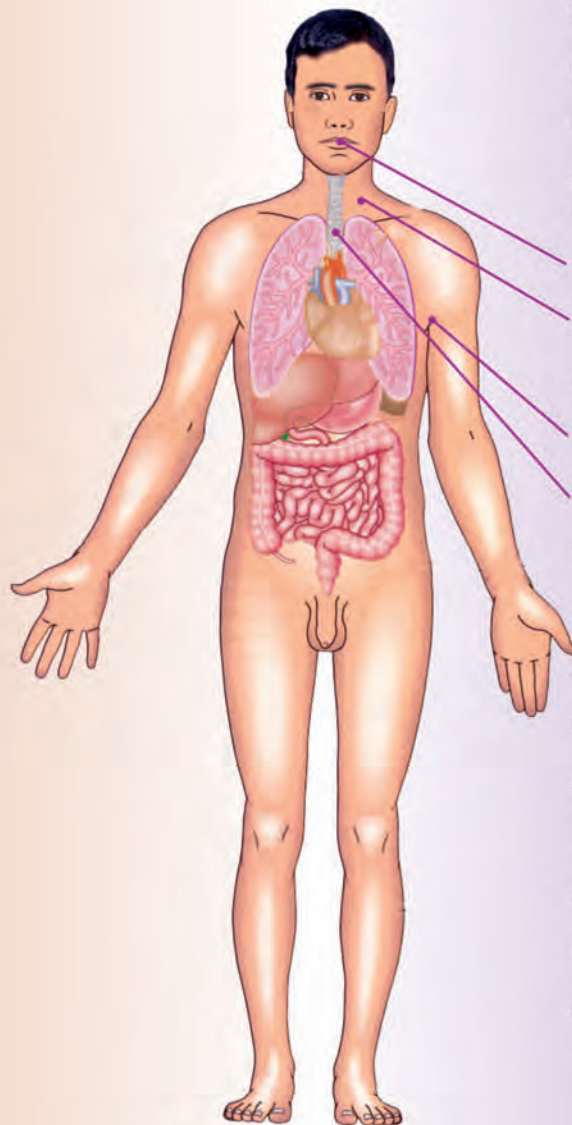

Anatomical Landmarks

The trachea bifurcates at the level of angle of Louis anteriorly and between the 4th and 5th thoracic spines posteriorly.

The second costal cartilage is connected to the angle of Louis. The ribs are counted downwards from the second rib.

Angle of Louis is the transverse bony ridge at the junction of the body of the sternum and the manubrium sterni.

Major interlobar fissure (Fig. 4.1) is marked by a line drawn from T₂ spine along the medial border of the scapula, with the arm kept hyperabducted, to the 6th rib at its costochondral junction, crossing the 5th rib at the mid axillary line. It corresponds to the upper border of the lower lobe.

Minor interlobar fissure (Fig. 4.1) is marked by a horizontal line drawn from the sternum at the level of 4th costal cartilage to meet the first line of the major interlobar fissure. It marks the boundary between the upper and middle lobes.

Bronchopulmonary Segments

Each main bronchus divides into three lobar bronchi. On the right side, one each to the upper lobe, middle lobe and lower lobe. On the left side, one each to upper lobe, lingular lobe and remainder of the lower lobe. Then these divide into segmental bronchi to individual segments.

The bronchopulmonary segments of the lungs on both the left and right side is given in the next column with their numbers.

Borders of the Lung

The apices of the upper lobes of both the lungs rise 2-3 cm. above the clavicles. From the apices of the upper lobe the inner margins of the lungs and their covering pleura start towards the sternum, meeting each other in the midline at the sternal angle. On the right, the margin of the lungs continue down the sternum as far as the 6th costal cartilage and then run outwards and downwards to meet the mid axillary line at the 8th rib, the scapular line at the 10th rib and the para vertebral line at the T₁₀ vertebrae. The landmark of the left lung is the same except that the lung border turns away from the sternum at the 4th instead of 6th costal cartilage due to the position of the heart.

	<i>Right side</i>		<i>Left side</i>
Upper	Apical (1) Posterior (2) Anterior (3)	Upper	Apical (1) Posterior (2) Anterior (3)
Middle	Lateral (4) Medial (5)	Lingular	Superior (4) Inferior (5)
Lower	Apical (6) Medial basal (7) Anterior basal (8) Lateral basal (9) Posterior basal (10)	Lower	Apical (6) Anterior basal (7) Lateral basal (8) Posterior basal (9)

Pleural Border

At the apices and along the inner margins of the lungs, the pleura lies close to the lungs to follow the same surface marking; but at the lower border of the lung, the pleura extends 4-5 cm anteriorly and 9-10 cm posteriorly below the lung, lying at the level of eighth

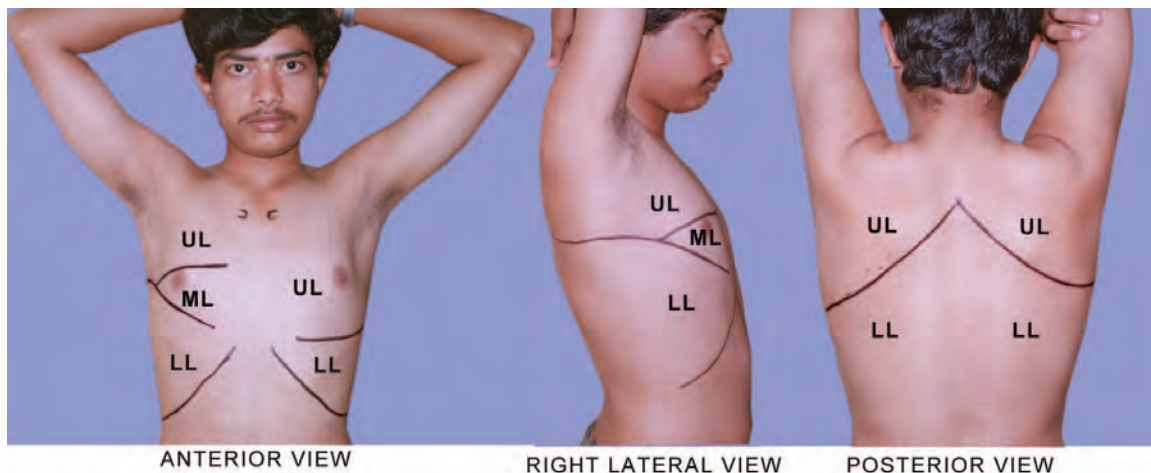

Fig. 4.1: Surface marking of major (right and left) fissures and minor fissure (right)



rib in the mid clavicular line, tenth rib at the mid axillary line and twelfth rib at the scapular line.

Upper lobes of the lung are accessible from the front, lower lobes from the back and all the three lobes in the axilla.

Symptoms and Signs

Cough

It is the reflex act of forceful expiration against a closed glottis that helps in clearing the airways including foreign body.

Mechanism of Cough

It is brought about by contraction of respiratory muscles against the closed glottis with a resultant increase in intrathoracic pressure followed by opening of the glottis with forced expiration at very high air flow rate in the upper airways.

Types of Cough

1. *Dry cough*: Pleural disorders, interstitial lung disease, mediastinal lesions
2. *Productive cough*: Suppurative lung disease, chronic bronchitis, pulmonary TB
3. *Short cough*: It is seen in upper respiratory tract infections (common cold)
4. *Brassy cough*: Cough with metallic sound produced by compression of the trachea by intrathoracic space occupying lesions
5. *Bovine cough*: Cough with loss of its explosive nature, e.g. tumours pressing on recurrent laryngeal nerve
6. *Prolonged and paroxysmal cough*: It is present in chronic bronchitis and whooping cough
7. *Barking cough*: It is found in epiglottal involvement as well as in hysterical and nervous individuals.

Cough syncope (Post-tussive syncope): It is due to raised intrathoracic pressure, which reduces venous return to the heart, thereby diminishing cardiac output, resulting in cerebral hypoperfusion and syncope.

Nocturnal cough: It is present in the following conditions:

1. Chronic bronchitis
2. Left sided failure
3. Bronchial asthma
4. Aspiration
5. Tropical eosinophilia
6. Post-nasal drip.

Drug induced cough is present in drug therapy with ACE inhibitors.

Sputum

It is a mixture of tracheobronchial secretion, cellular debris, micro-organisms and saliva. The character of sputum is determined by its amount, colour, chronology, consistency and smell.

Saliva contains squamous cells.

Sputum contains epithelial cells. If sputum contains epithelial cells and eosinophils then suspect.

- a. Bronchial asthma
- b. Allergic bronchopulmonary aspergillosis (ABPA).

Amount

Bronchorrhoea: When the quantity of sputum production is > 100 ml/day, it is termed as bronchorrhoea.

Copious sputum production is seen in conditions like:

1. Bronchiectasis
2. Lung abscess
3. Empyema rupturing into the bronchus
4. Necrotising pneumonia
5. Alveolar cell carcinoma.

Copious sputum production upon changes in posture is seen in bronchiectasis and lung abscess. This postural relationship to cough is due to irritation of the healthy bronchial mucosa.

Large amount of colourless sputum is present in alveolar cell carcinoma.

Chronology

Chronic bronchitis: Sputum production is more in the early morning for many years.

Bronchial asthma: Sputum production is more either in the morning or at night. Recent onset of sputum production signifies severe infection.

Colour of the Sputum

- a. Green or yellow coloured thick sputum indicates bacterial infections. The green colour to sputum is imparted by the enzyme myeloperoxidase (verdo-peroxidase)
- b. Black coloured sputum is present in coal worker's pneumoconiosis
- c. Rusty sputum is present in pneumococcal pneumonia
- d. Red currant jelly sputum is seen in *Klebsiella pneumonia*
- e. Pink frothy sputum is present in pulmonary oedema
- f. Blood stained sputum is present in tuberculosis
- g. Anchovy sauce sputum is present in ruptured amoebic liver abscess.

**Consistency**

Serous: It is clear, watery and frothy. It is seen in bronchoalveolar carcinoma. It may be pink, as occurs in pulmonary oedema.

Mucoid: It is clear, greyish white or black in colour and frothy. It may be seen in conditions like chronic bronchitis and chronic asthma.

Mucopurulent or purulent: Yellowish or greenish brown in colour, seen in bacterial infection.

Bronchial asthma: Macroscopically the sputum is 'worm like', which are remnants of casts of bronchus. Microscopically, the sputum consists of:

- Eosinophils
- Desquamated epithelium
- Curschmann spirals (whorled mucous plugs)
- Charcot-Leyden crystals (crystalloid debris of eosinophil membrane)
- Creola bodies (exfoliated cells due to disruption of mucosal integrity).

Odour of Sputum

Offensive and foetid:

- Lung abscess
- Bronchiectasis
- Anaerobic bacterial infection.

Haemoptysis

It is defined as expectoration of blood, or bloody sputum.

Types of Haemoptysis

Frank haemoptysis: It is the expectoration of blood only. Massive and fatal blood loss may occur. Frank haemoptysis daily suggests bronchogenic carcinoma.

Haemoptysis in suppurative lung disease: Large quantities of foul smelling sputum and blood suggests suppurative lung disease.

Spurious haemoptysis: Haemoptysis present secondary to upper respiratory tract infection, above the level of larynx.

Pseudohaemoptysis: It is due to pigment, prodigiosin produced by gram-negative organism, *Serratia marcescens*.

Endemic haemoptysis: Present in infection with *Paragonimus westermani* (lung fluke).

Severity of Haemoptysis

Mild < 100 ml blood loss per day
Moderate 100–150 ml blood loss per day

Severe Up to 200 ml blood loss per day
Massive > 500 ml blood loss per day (or) rate of blood loss > 150 ml/hr (or) 100 ml blood loss per day for more than 3 days.

If there is > 500 ml blood loss per day, aggressive intervention (rigid bronchoscopy or surgery) is advocated. If the blood loss is submassive, after subsidence of haemoptysis, fibreoptic bronchoscopy is indicated.

**Causes of Haemoptysis****Infection**

- Tuberculosis
- Lung abscess
- Bronchiectasis
- Pneumonia
- Fungal infection (aspergillosis, nocardiosis, blastomycosis).

Differences between Haemoptysis and Haematemesis

<i>Haemoptysis</i>	<i>Haematemesis</i>
1. Cough precedes haemoptysis	Nausea and vomiting precedes haematemesis
2. Frothy due to admixture of air	Not frothy
3. pH alkaline	pH acidic
4. Mixed with macrophage and neutrophil	Mixed with food particles
5. Malaena absent	Malaena present
6. Bright red in colour	Dark brown in colour due to acid haematin
7. Previous history of respiratory disease	Previous history of peptic ulcer disease
8. Diagnosed by bronchoscopy	Diagnosed by gastroscopy

Neoplasm

- Bronchogenic carcinoma
- Bronchial adenoma
- Metastatic tumour to lung.

Cardiovascular Disorders

- Mitral stenosis
- Pulmonary hypertension
- Aortic aneurysm
- Arteriovenous malformation
- Pulmonary embolism.

Congenital

- Bronchial cyst
- Sequestration of lung
 - Intralobar
 - Extralobar.



Collagen Vascular Disorder

- a. Vasculitis
- b. Wegener's granulomatosis
- c. Goodpasture's syndrome.

Traumatic

- a. Non-iatrogenic
 - i. Blunt injury
 - ii. Inhalation of toxic gases or acid aspiration
- b. Iatrogenic

i. Diagnostic	Biopsy procedure
ii. Therapeutic	Anticoagulants
	Radiation fibrosis.

Miscellaneous

Bleeding disorders.

Haemoptysis is uncommon in

1. Metastatic lesions of the lung except in secondaries due to choriocarcinoma and renal cell carcinoma.
2. Viral infection.

Dyspnoea

It is defined as the undue awareness of respiratory effort or of the need to increase the effort.

Increased work of breathing is required in:

1. Thickened pleura
2. Pleural effusion
3. Pneumothorax
4. Airway resistance.

Increased demand of breathing is present in conditions like:

1. Hypoxia
2. Anaemia
3. Acidosis
4. Thyrotoxicosis.

Increased respiratory effort is needed in:

1. Breath-holding
2. Paralysis of respiratory muscles.

Grading of Dyspnoea

Medical Research Council Classification

- Grade I Shortness of breath when hurrying on a level ground or walking up a small hill.
- Grade II Shortness of breath when walking with people of same age group on level ground.

Grade III Shortness of breath when walking at own pace on level ground, having to stop for breath in between.

Sherwood Jones Classification

Grade I: Able to do household work

- a. With moderate difficulty
- b. With great difficulty.

Grade II: Confined to chair or bed and

- a. Able to get up with moderate difficulty
- b. Able to get up with great difficulty.

Grade III: Totally confined to chair or bed.

Grade IV: Moribund.

Receptors Involved in Mechanism of Dyspnoea

1. J receptors, situated at the alveolo-capillary junction, are responsible for rapid shallow breathing and they are stimulated by pulmonary congestion, oedema or microemboli
2. The stretch receptors in thoracic cage and lung
3. The chemoreceptors in the carotid arteries, aorta and reticular substance of medulla which respond to oxygen lack, carbon dioxide excess and decrease in pH
4. Receptors in the respiratory muscle which are immediate cause of appreciation of dyspnoea.

Clinical Aspects of Dyspnoea

Onset of dyspnoea can be as follows:

Dyspnoea occurring within

Minutes

- Pneumothorax
- Pulmonary oedema due to cardiac arrhythmias
- Major pulmonary embolism
- Inhalation of foreign body
- Laryngeal oedema.

Hours

- Asthma (but can also be acute)
- Left heart failure
- Pneumonia.

Days

- Pneumonia
- Adult respiratory distress syndrome
- Left heart failure
- Repeated pulmonary embolism

Weeks

- Pleural effusion



- Anaemia
- Muscle weakness
- Tumours.

Months

- Pulmonary fibrosis
- Thyrotoxicosis
- Muscle weakness.

Years

- Muscle weakness
- Chronic obstructive pulmonary disease
- Chest wall disorders.

Chest Pain**Pleural Pain**

It is caused by stretching of the inflamed parietal pleura. Present in all forms of pleurisy. It is a stabbing type of catchy pain occurring with deep inspiration or coughing and relieved by shallow breathing or lying on the affected side. Detailed description is dealt with in chapter on pain.

Time of Onset

Sudden onset	Spontaneous pneumothorax, pulmonary embolism
Gradual onset	Pneumonia.

Pancoast Syndrome

Pancoast syndrome is caused by either a superior sulcus tumour (*Pancoast tumour*) or superior sulcus infiltrative disorder, e.g. pulmonary tuberculosis.

The components of this syndrome are:

- Compression of C₈, T₁, T₂ nerve roots resulting in shoulder and arm pain
- Compression of the cervical sympathetic chain and stellate ganglion, producing Horner's syndrome
- Erosion of adjacent ribs and vertebrae, producing a constant chest pain.

Upper Retrosternal Pain

It is a momentary pain which increases in intensity on coughing and subsides when the cough becomes productive. It is seen in acute tracheitis.

Mid or Lower Retrosternal Pain

It is constrictive in character and may be present in:

1. Acute mediastinitis
2. Mediastinal tumour

3. Mediastinal emphysema
4. Reflux esophagitis
5. Achalasia cardia.

General Examination

1. Build
2. Nourishment
3. Dyspnoea
4. Cyanosis (Mode of onset of respiratory disorder determines the presence or absence of cyanosis. In acute respiratory disease, lesser area of involvement can result in cyanosis, as occurs in lobar pneumonia. In chronic lung disorder, unless bilateral extensive involvement is present, cyanosis may be absent)
5. Anaemia may occur when there is
 - a. Haemoptysis
 - b. Excessive sputum production and protein loss
 - c. Loss of appetite leading to malnutrition
6. Jaundice may be seen with
 - a. Pulmonary infarction
 - b. Iatrogenic (drugs)
 - c. Liver secondaries (obstructive jaundice)
 - d. Pneumonia (pneumococcal)
7. Clubbing
8. Lymphadenopathy
9. Eye
10. Pedal oedema (cor pulmonale, hypoproteinaemia due to protein loss in sputum).

Clubbing (Fig. 4.2)

It is a selective bulbous enlargement of the distal portion of the digit due to increased subungual soft tissue.

The normal angle between the nail and the nail-bed is 160° and is known as the *Lovibond angle*.

The minimum duration required for clubbing to manifest is 2 to 3 weeks. Clubbing first appears in the index finger.



Fig. 4.2: Clubbing



Fig. 4.3: Testing for fluctuation



Fig. 4.4: Normal nail-bed angle

Grading of Clubbing

- Grade I Obliteration of the angle between the nail and the nail-bed and positive fluctuation test (Fig. 4.3)
- Grade II Parrot beak appearance
- Grade III Drumstick appearance
- Grade IV Hypertrophic osteoarthropathy.

Schamroth's Sign

When the dorsum of the distal phalanges of the fingers of both hands are approximated to each other, a diamond shaped gap (Fig. 4.4) is made out due to the presence of the Lovibond angle. This gap disappears with obliteration of this angle, as occurs with clubbing.

Hypertrophic Osteoarthropathy

It is a painful swelling of the wrist, elbow, knee, ankle, with radiographic evidence of sub-periosteal new bone formation. It can be familial or idiopathic.

Other common disorders that can produce it are:

- Bronchogenic carcinoma
- Cystic fibrosis
- Neurofibroma
- A-V malformation.

Theories of Clubbing

- Neurogenic*: Vagal stimulation causes vasodilatation and clubbing
- Humoural*: GH, PTH, oestrogen, PG, bradykinin cause vasodilatation and clubbing
- Ferritin*: Decreased ferritin in systemic circulation causes dilatation of A-V anastomosis and hypertrophy of the terminal phalanx
- Hypoxia*: Persistent hypoxia causes opening of deep A-V fistulae of the terminal phalanx
- Platelet derived growth factor*: This factor which is released secondary to infection anywhere in the body, also causes vasodilatation and this is the latest and most acceptable theory for clubbing.



Causes of Clubbing

Congenital/Familial*

Note: *Congenital hypertrophic pulmonary osteoarthropathy—Pachydermoperiostosis.

Acquired

- Unidigital or pandigital
- Unilateral or bilateral
- Differential.

Unidigital clubbing: It is seen in:

- Tophaceous gout
- Local injury
- Sarcoidosis.

Unilateral clubbing: It is seen in:

- Aneurysmal dilatation of aorta, subclavian or innominate arteries
- Brachial AV fistula
- Haemiplegia
- Pancoast tumour.

Differential clubbing: It is seen in PDA with reversal, with cyanosis and clubbing occurring in the lower limbs only.

**Pulmonary and Thoracic Causes**

- a. Bronchogenic carcinoma (rare in adenocarcinoma)
- b. Metastatic lung cancer
- c. Suppurative lung disease
 1. Bronchiectasis
 2. Cystic fibrosis
 3. Lung abscess
 4. Empyema
- d. Interstitial lung disease
- e. Longstanding pulmonary tuberculosis
- f. Chronic bronchitis
- g. Mesothelioma
- h. Neurogenic diaphragmatic tumour
- i. Pulmonary AV malformation
- j. Sarcoidosis.

**Cardiovascular Causes**

- a. Cyanotic congenital heart disease
- b. Bacterial endocarditis
- c. Atrial myxoma
- d. Eisenmenger's syndrome.

**Gastrointestinal Causes**

- a. Cirrhosis of liver (more common in biliary cirrhosis)
- b. Ulcerative colitis
- c. Crohn's disease
- d. GIT malignancy.

Miscellaneous

- a. Syphilis
- b. Syringomyelia
- c. Acromegaly
- d. Thyrotoxicosis.

Pseudo-clubbing

It may be seen in:

- a. Hansen's disease due to resorption of tissue
- b. Vinyl chloride worker due to focal tissue reaction to the chemical
- c. Leukaemia due to tissue infiltration
- d. Hyperparathyroidism due to bone resorption.

Examination of the Eye

<i>Signs</i>	<i>Diseases</i>
Horner's syndrome	Pancoast tumour
Iridocyclitis	Tuberculosis and collagen vascular disorder
Phlycten	Tuberculosis (Primary)
Chemosis and dilatation of retinal and conjunctival veins	Superior vena caval syndrome and hypercapnoea
Choroid tubercle	Tuberculosis (Miliary)
Papilloedema	Chronic obstructive pulmonary disease and SVC obstruction
Colour blindness	Ethambutol (Red-green colour blindness)

Examination of the Neck**Scalene Lymph Node**

It is a group of nodes in a pad of fat on the surface of scalenus anterior muscle just in front of its insertion into the scalene tubercle of the 1st rib.

Significant Node

It is one which is round in shape, 0.5 cm in diameter and firm in consistency. It is:

1. Large and fixed in secondary involvement from a primary lung malignancy
2. Hard and craggy, matted, with or without sinus formation in healed and calcified tuberculous lymphadenopathy.

Other significant lymph nodes to be palpated are:

1. Supraclavicular lymph node (presence of left supraclavicular node or Virchow's node is known as Troisier's sign)
2. Cervical lymph node
3. Axillary lymph node (parietal pleura involvement with infiltration into subcutaneous tissue and skin, breast and upper limb disorders).

Lymphatic Drainage of the Lung and Pleura

- a. Parietal pleura to axillary lymph node
- b. Whole of right lung and left lower lobe to right supraclavicular lymph node
- c. Left upper lobe to left supraclavicular lymph node (Troisier's sign).

N.B. Genito-urinary system and gastrointestinal system malignancies also involve the left supraclavicular lymph node due to retrograde permeation.



Fig. 4.5: SVC obstruction

Presence of Veins over the Chest Wall

In superior vena caval syndrome look for presence of distended veins over the chest wall (Fig. 4.5).

If the obstruction to SVC is above the level of azygos vein, collateral venous circulation on the anterior surface of chest wall is less prominent as the intercostal veins drain into the azygos vein.

If the obstruction to SVC is at or below the level of azygos vein, collateral veins on the chest become prominent as these collaterals carry blood caudally to the IVC.



Causes of SVC Obstruction

Malignant causes

1. Bronchogenic carcinoma
 - a. Small cell carcinoma 40%
 - b. Squamous cell carcinoma 25%
 - c. Adenocarcinoma 15%
 - d. Large cell carcinoma 12%
 - e. Unclassified 8%
2. Hodgkin's lymphoma
3. Thymoma
4. Mediastinal germ cell tumour
5. Neuroblastoma
6. Metastasis from carcinoma breast or prostate.



Non-malignant Causes

1. Mediastinal fibrosis (TB, syphilis and histoplasmosis)
2. Thrombosis induced by interventional procedures (Pacemaker catheter, Le Vein shunt, Swan-Ganz catheter, CV access devices)

3. Aortic aneurysm
4. Haematoma
5. Mediastinal sclerosis
6. Post-irradiation.

External Manifestations of Respiratory Diseases

- a. Asterixis—respiratory failure
- b. Halitosis—suppurative lung disease
- c. Gynaecomastia—INH, digoxin, bronchogenic carcinoma
- d. Horner's syndrome—Pancoast tumour
- e. Small muscle wasting—Pancoast tumour
- f. External markers of tuberculosis
 1. Tinea versicolor
 2. Lupus vulgaris
 3. Erythema nodosum
 4. Scrofuloderma (caused by atypical mycobacteria, *M. scrofulaceum*)
 5. Epididymo-orchitis
- g. External markers of cor pulmonale
 1. Raised jugular venous pressure
 2. Pedal oedema
 3. Ascites
 4. Liver enlargement.

Examination of the Respiratory System

Inspection of Upper Respiratory Tract

- a. Oral cavity
 1. Oral hygiene
 2. Dental caries
 3. Oral thrush
 4. Tonsils.
- b. Nose
 1. Deviated nasal septum
 2. Nasal polyps may be seen in
 - i. Wegener's granulomatosis
 - ii. Allergic asthma
 - iii. ABPA
 - iv. Cystic fibrosis.
- c. Pharynx—Post-nasal drip, lymphoma deposits.

Inspection of Lower Respiratory Tract

All the findings in the clinical examination should be compared on both sides in the following areas:

1. Supraclavicular area
2. Infraclavicular area
3. Mammary region
4. Axillary region
5. Infra-axillary region



6. Suprascapular region
7. Interscapular region
8. Infrascapular region.

Position of Trachea

Trail's sign: It is the undue prominence of the clavicular head of sternomastoid on the side to which the trachea is deviated.

The pretracheal fascia encloses the clavicular head of sternomastoids on both sides. When the trachea is shifted to one side, the pretracheal fascia covering the sternomastoid on that side relaxes, making the clavicular head more prominent on the side of tracheal deviation.

Position of Apex Beat

The apex beat is shifted to the side of mediastinal shift.

Symmetry of Chest

Normal chest is symmetrical and elliptical in cross section. The normal antero-posterior to transverse diameter ratio is 5 : 7. The normal subcostal angle is 90°. It is more acute in males than in females.

Look for the following:

1. Drooping of the shoulder
2. Hollowness or fullness in the supraclavicular and infraclavicular fossae
3. Crowding of ribs
4. Kyphosis (forward bending of the spine)
5. Scoliosis (lateral bending of the spine).

Acquired scoliosis can be differentiated from congenital scoliosis as follows. If the convexity of the spine and the lung lesion are on the same side, it is most likely that the scoliosis is congenital. If the convexity of the spine is on one side and the lung lesion is on the opposite side, it indicates an acquired scoliosis. This dictum may not always be true.

The skin over the chest wall is examined for the following:

- a. Engorged veins and subcutaneous nodules (sarcoid and malignancy)
- b. Intercostal scar (drained pleural effusion, empyema or pneumothorax)
- c. Discharging sinuses (TB)
- d. Empyema necessitans in which there is an intercostal swelling close to the sternum.

Chest Deformities

1. *Flat chest:* The antero-posterior to transverse diameter ratio is 1 : 2. Seen in pulmonary TB and fibrothorax



Fig. 4.6: Pectus carinatum

2. *Barrel chest:* The anteroposterior to transverse diameter ratio is 1 : 1. Seen in physiological states like infancy and old age and in pathological states like COPD (emphysema)
3. *Pigeon chest (Pectus carinatum)* (Fig. 4.6): It is forward protrusion of sternum and adjacent costal cartilage, seen in Marfan's syndrome, in childhood asthma and rickets
4. *Pectus excavatum (funnel chest, cobbler's chest)* (Fig. 4.7): It is the exaggeration of the normal hollowness over the lower end of the sternum. It is a developmental defect. The apex beat shifted further to the left and



Fig. 4.7: Pectus excavatum



the ventilatory capacity of the lung is restricted. It is seen in Marfan's syndrome

5. *Harrison's sulcus*: It is due to the indrawing of ribs to form symmetrical horizontal grooves above the costal margin, along the line of attachment of diaphragm due to hyperinflation of the lungs and repeated strong contraction of the diaphragm as occurs in chronic respiratory disease in childhood, childhood asthma, rickets and blocked nasopharynx due to adenoid enlargement
6. *Rickety rosary*: It is a bead like enlargement of costochondral junction, e.g. rickets
7. *Scorbutic rosary*: It is the sharp angulation, with or without beading or rosary formation, of the ribs, arising as a result of backward displacement or pushing in of the sternum, e.g. Vitamin C deficiency.

Spinal Deformity

Kyphoscoliosis (Figs 4.8 and 4.9): It is a disfiguring or disabling deformity of the spine, producing a shift of the apex beat. It reduces the ventilatory capacity of the lung and increases the work of breathing.

Ankylosing spondylitis: In this condition, there is a diminished volume of the lung and the capacity of the chest and thereby the capacity of lung to expand is restricted.

Movement of the Chest

It is described in terms of rate, rhythm, equality and type of breathing.



Fig. 4.8: Kyphosis



Fig. 4.9: Scoliosis

Rate

- The normal respiratory rate in relaxed adults is 14-18 breaths per minute
- The type of breathing in women is thoraco-abdominal and in men is abdomino-thoracic
- The ratio of pulse rate to respiratory rate is 4 : 1.

Tachypnoea: It is an increase in respiratory rate more than 20 per minute. Conditions causing tachypnoea are:

- a. Nervousness
- b. Exertion
- c. Fever
- d. Hypoxia
- e. Respiratory conditions
 - i. Acute pulmonary oedema
 - ii. Pneumonia
 - iii. Pulmonary embolism
 - iv. ARDS
 - v. Metabolic acidosis.

Bradypnoea: It is a decrease in the rate of respiration. Conditions causing bradypnoea are:

- a. Alkalosis
- b. Hypothyroidism (myxoedema)
- c. Narcotic drug poisoning
- d. Raised intracranial tension.

Hyperpnoea: It is an increase in depth of respiration. Conditions causing hyperpnoea are:

- a. Acidosis
- b. Brainstem lesion
- c. Hysteria.

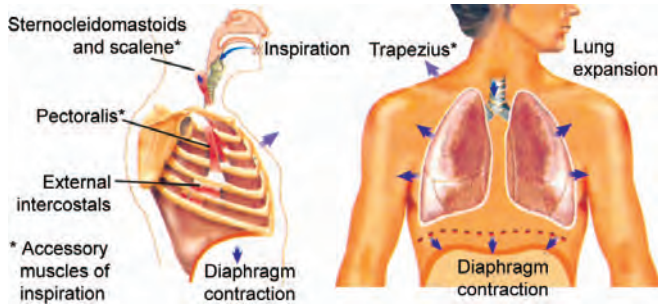

Fig. 4.10: Muscles of inspiration

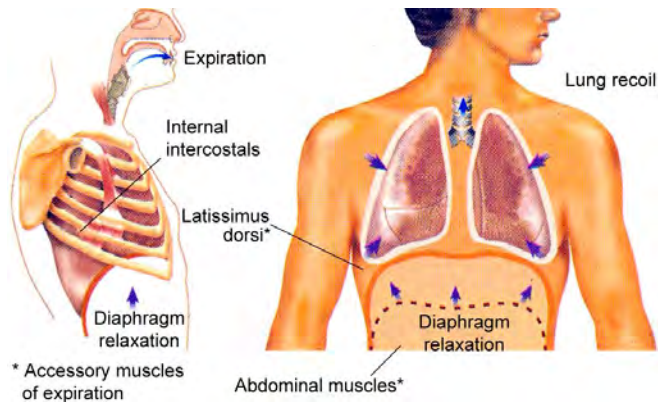

Fig. 4.11: Muscles of expiration

Rhythm

Inspiration: It is an active process brought about by the contraction of the external intercostal muscles and the diaphragm (Fig. 4.10).

Expiration: It is a passive process and it depends upon elastic recoil of the lungs.

Accessory muscles of inspiration (Fig. 4.10) are the scaleni, trapezius and pectoral muscles.

Accessory muscles of expiration (Fig. 4.11) are abdominal muscles and latissimus dorsi.

Abnormal Breathing Patterns

Abnormal breathing patterns may be regular or irregular (Fig. 4.12).

Regular abnormal breathing patterns

- Cheyne-Stokes breathing:** It is characterised by hyperpnoea followed by apnoea. It occurs in cardiac failure, renal failure, narcotic drug poisoning and raised intracranial pressure
- Kussmaul's breathing:** It is characterised by increase in rate and depth of breathing. It occurs in metabolic acidosis and pontine lesions.

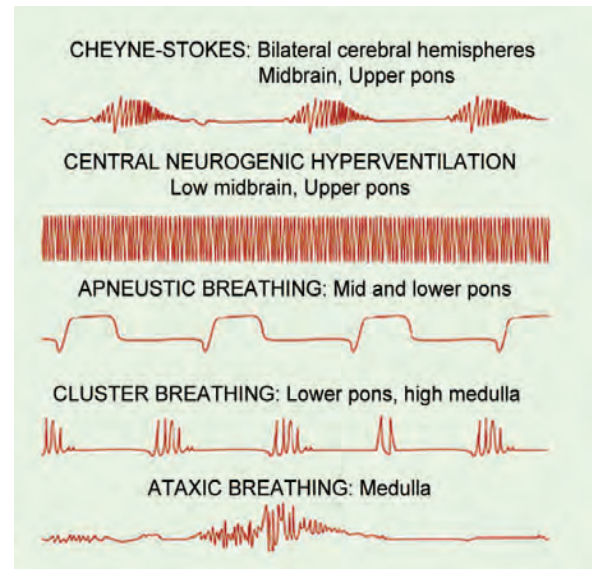

Fig. 4.12: Abnormal respiratory patterns

Irregular abnormal breathing patterns

- Biots breathing:** It is characterised by apnoea between several shallow or few deep inspirations. It occurs in meningitis
- Ataxic breathing:** It is characterised by irregular pattern of breathing where both deep and shallow breaths occur randomly. It occurs in brainstem lesions
- Apneustic breathing:** It is characterised by pause at full inspiration, alternating with a pause in expiration, lasting for 2 to 3 seconds. It occurs in pontine lesions
- Cogwheel breathing:** It is an interrupted type of breathing pattern, seen in nervous individuals
- Pursed lip breathing:** This form of breathing is seen in patients with COPD especially with emphysema. The patient breathes out against a pursed lip as this manoeuvre helps in increasing the intrabronchial pressure above the surrounding alveoli and prevents its collapse.

Palpation

The position of the trachea is confirmed by slightly flexing the neck so that the chin remains in the midline. The index finger is then inserted in the suprasternal notch and the tracheal ring is felt. Slight shift of trachea to the right is normal (Figs 4.13 and 4.14).

Tracheal Tug-Olliver's Sign

This sign is elicited by standing behind the patient. The chin of the patient is raised and the cricoid cartilage is



Fig. 4.13: Methods of palpating trachea



Fig. 4.14: Assessing tracheal position

held up on deglutition on either side with fingers of both hands. The sign is said to be positive when a downward tug is felt by the fingers during cardiac systole. This sign is present in aortic arch aneurysm.

False-positive sign: In mediastinal tumour attached to aortic arch.

False-negative sign: In non-pulsatile aortic aneurysm (when thrombosed).

Inspiratory Tracheal Descent

Tracheal descent with inspiration can be seen in the suprasternal region in chronic obstructive air way diseases.

Confirmation of Apical Impulse

The shift of the apical impulse and trachea in the absence of chest deformity indicates mediastinal shift. External mass lesions like thyroid, thymus, lymph nodes causing displacement of trachea must be kept in mind while ascertaining tracheal position.

The Position of Apical Impulse is Altered in

- Scoliosis (scoliosis with right sided convexity will displace the cardiac impulse further to the left)
- Funnel-shaped depression of the sternum
- Enlargement of ventricle
- In the absence of the above conditions, the shift of trachea and apical impulse is due to disease of the lung altering the position of the mediastinum.

The trachea is 'pushed' to the opposite side in conditions like:

- Pleural effusion
- Pneumothorax
- Tumour.

The trachea is 'pulled' to the same side in conditions like:

- Fibrosis
- Collapse of the lung.

The trachea may be shifted to the same side in the presence of pleural effusion in the following conditions:

- Mesothelioma
- Empyema or effusion following pre-existing fibrosis
- Mass with collapse and pleural effusion.

Measurement of the Chest Expansion

This is done using an inch tape. The normal circumference of the chest and its expansion with deep inspiration is measured.

In males, the measurement is done at the level of the nipple and in the females the measurement is done below the breasts.

Normal expansion of the chest is 5-8 cm

In severe emphysema, it is less than 1 cm

Non-respiratory cause giving rise to poor chest expansion—Ankylosing spondylitis.

Assessing Symmetry of Chest Expansion

Equality of expansion of the upper part of thorax is done by facing the patient's back and placing both hands over the patient's supraclavicular fossae. The extent of upward movement of the hands, during quiet respiration, is compared on both sides (Fig. 4.15).

Equality of expansion of the mid and lower part of thorax is assessed as follows.

Assessment of Anterior Thoracic Movement (Fig. 4.16)

The examiner faces the patient and keeps his finger tips of both the hands on either side of the patient's rib cage



Fig. 4.15: Assessment of upper thoracic expansion



Fig. 4.17: Assessment of posterior thoracic movement



Fig. 4.16: Assessment of anterior thoracic expansion



Fig. 4.18: Method 2 for assessing chest expansion

so that the tips of the thumb approximate each other in the midline without touching the chest wall. After a deep breath, the degree of expansion is compared on both sides by movement of the thumb away from the midline.

Assessment of Posterior Thoracic Movement

A similar procedure is carried out over the posterior aspect of the patient's chest (Fig. 4.17).

The difference in chest expansion can be assessed by holding a loose fold of skin in between the thumbs, approximated in the midline, whereby even a slight difference in chest expansion can be assessed easily. (The skin fold disappears on the side of good expansion) (Fig. 4.18).

Minimal difference in chest expansion of the two hemithoraces can be assessed in a cooperative patient, without dyspnoea in the following way. The patient is asked to expire fully thereby obtaining the residual lung volume, and then to inspire to his full capacity thereby attaining total lung capacity. The difference in expansion of each hemithorax can then be assessed.

Tenderness over the Chest Wall

It may be due to:

1. Empyema
2. Local inflammation of parietal pleura, soft tissue and osteomyelitis



3. Infiltration with tumour
4. Non-respiratory cause (amoebic liver abscess).

Detection of Subcutaneous Emphysema

Spongy crepitant feeling on palpation suggests subcutaneous emphysema. It is present in:

1. Injury to chest wall and rib
2. Pneumothorax
3. Rupture of oesophagus.

Tactile Fremitus

These are palpable added sounds (rhonchi are better felt than crackles).

Friction Fremitus

It is a palpable pleural rub.

Vocal Fremitus

It is a vibration felt by the hand when the patient is asked to repeat ninety-nine or one-one-one, by putting the vocal cord into action. Identical areas of the chest are compared on both sides. It is felt with the flat of the hand or with the ulnar border of the hand for accurate localisation. It is increased in consolidation. It is decreased in pleural effusion.



Special Clinical Features of Importance

General Restriction of Expansion

- a. COPD
- b. Extensive bilateral disease
- c. Ankylosing spondylitis
- d. Interstitial lung disease
- e. Systemic sclerosis (hide bound chest).

Asymmetrical Expansion of the Chest

- a. Pleural effusion
- b. Pneumothorax
- c. Extensive consolidation
- d. Collapse
- e. Fibrosis.

In all these above conditions, diminished expansion occurs on the affected side.

Percussion of the Lung Fields

General Principles

Position of the Patient

The sitting posture is the best position of choice for percussion. Supine posture is not desirable because of

the alteration of the percussion note by the underlying structure on which the patient lies.

- a. *Anterior percussion*: The patient sits erect with the hands by his side
- b. *Posterior percussion*: The patient bends his head forwards and keeps his hands over the opposite shoulders. This position keeps the two scapulae further away so that more lung is available for percussion
- c. *Lateral percussion*: The patient sits with his hands held over the head.

Objectives of Percussion

It is done to find out the degree of resonance over the symmetrical areas of the two sides of the chest and to map out areas in which percussion note is abnormal.

Cardinal Rules of Percussion

- a. *The pleximeter*: The middle finger of the examiner's left hand should be opposed tightly over the chest wall, over the intercostal spaces. The other fingers should not touch the chest wall. Greater pressure should be applied over a thick chest wall to remove air pockets
- b. *The plexor*: The middle or the index finger of the examiner's right hand is used to hit the middle phalanx of the pleximeter
- c. The percussion movement should be sudden, originating from the wrist. The finger should be removed immediately after striking to avoid damping
- d. Proceed from the area of normal resonance to the area of impaired or dull note, as the difference is then easily appreciated
- e. The long axis of the pleximeter is kept parallel to the border of the organ to be percussed.

Areas of Percussion (Fig. 4.20)

Anterior Chest Wall

- a. *Clavicle*: Direct percussion is used and percussion is done within the medial 1/3rd of the clavicle (Fig. 4.19)
- b. *Supraclavicular region (Kronig's isthmus)*: It is a band of resonance 5-7 cm size over the supraclavicular fossa. It is bounded medially by scalenus muscle of the neck, laterally by the acromion process of scapula, anteriorly by the clavicle and posteriorly by the trapezius. The percussion is done by standing behind the patient and the resonance of the lung apices is assessed by this method. Hyper resonance in this area indicates emphysema. Impaired resonance in



Fig. 4.19: Direct percussion—clavicle

this area indicates pulmonary TB or malignancy in the lung apex

- c. Infraclavicular
- d. Second to sixth intercostal spaces. However, the percussion note cannot be compared due to relative cardiac dullness on the left side.

Lateral Chest Wall

Fourth to seventh intercostal spaces.

Posterior Chest Wall

- a. Suprascapular (above the spine of the scapula)

- b. Interscapular region
- c. Infrascapular region up to the eleventh rib.

Types of percussion note	Lesions
1. Tympanitic	Hollow viscus
2. Subtympanitic (skodiatic resonance or boxy quality)	Above the level of pleural effusion
3. Hyper-resonant	Pneumothorax
4. Resonant	Normal lung
5. Impaired	Pulmonary fibrosis, cavity with surrounding fibrosis
6. Dull	Consolidation, collapse, Pleural thickening
7. Stony dull	Pleural effusion, empyema, Parenchymal lung disorder with pleural thickening

Crack Pot Resonance

A type of tympanitic note which can be produced by clasping the moist hands loosely together and striking it against the knee. It may be elicited over a large cavity communicating with a bronchus.

Normal Percussion Note in Diseased Lung

- 1. Chronic bronchitis
- 2. Bronchial asthma
- 3. Interstitial lung disease
- 4. Diffuse emphysema.

Percussion on the Right Side

Liver dullness can be percussed from the right 5th intercostal space downwards in the midclavicular line up to the right costal margin.

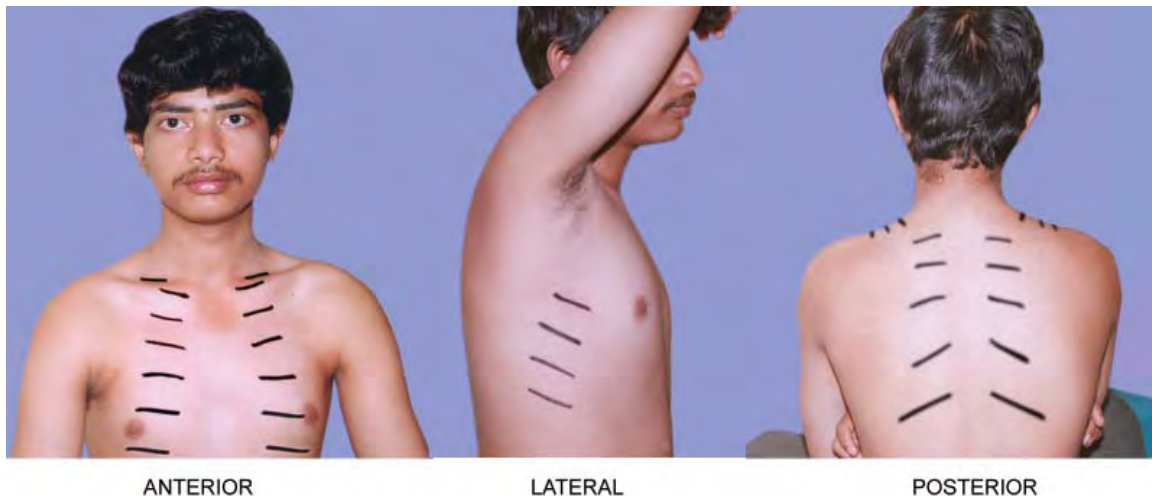

ANTERIOR

LATERAL

POSTERIOR

Fig. 4.20: Percussion areas



Tidal Percussion

This is done to differentiate upward enlargement of liver or subdiaphragmatic abscess from right sided parenchymal or pleural disorder.

If on deep inspiration, the previous dull note in the fifth right intercostal space on the mid clavicular line becomes resonant, it indicates that the dullness was due to the liver, which had been pushed down by the right hemidiaphragm with deep inspiration. If the dullness persists on the other hand, it indicates underlying right sided parenchymal or pleural pathology, in the absence of diaphragmatic paralysis.

Percussion on the Left Side

Traube's Space

Surface anatomy: Draw two parallel vertical lines, one from the left 6th costochondral junction and another from the 9th rib in mid axillary line. Then connect the two lines above from the left 6th costochondral junction to the 9th rib in mid axillary line and below along the left costal margin. It forms a semilunar space and is tympanitic on percussion.

Boundaries of Traube's space	
Right side	Left lobe of the liver
Left side	Spleen
Above	Left lung resonance
Below	Left costal margin
Content	Fundus of stomach

Traube's space is obliterated in:

1. Left sided pleural effusion
2. Massive splenomegaly
3. Enlarged left lobe of liver
4. Full stomach
5. Fundal growth
6. Massive pericardial effusion.

Traube's space is shifted upwards in:

1. Left diaphragmatic paralysis
2. Left lower lobe collapse
3. Fibrosis of the left lung.

Special Features of Clinical Importance

Percussion Tenderness

It is present in empyema and inflammation of parietal pleura.

Straight Line Dullness

It is present in hydropneumothorax.

Shifting Dullness

This is done to demonstrate the shift of fluid in pleural effusion and hydropneumothorax. In hydropneumothorax shifting occurs immediately, whereas it is very slow in case of pleural effusion. The immediate shift of fluid can be demonstrated by the dull area percussed in the axilla in the sitting posture, becoming resonant on lying down on the healthy side.

"S" Shaped Curve of Ellis

In moderate sized pleural effusion, the uppermost level of dullness is highest in the axilla and lowest in the spine, and tends to assume the shape of the letter "S". Hence the name.

One school of thought is that, this phenomenon is due to capillary suction between the two layers of the pleura, drawing the fluid up maximally in the axillary region.

Another school of thought is that this phenomenon is only a radiological illusion.

Auscultation

General Principles of Auscultation

- a. As most normal lung sounds are low pitched, the bell is normally preferred over the diaphragm. Stretching of the skin under the diaphragm during breathing is apt to produce scratching sound similar to a pleural rub. In order to avoid time consumption and practical difficulty, diaphragm is used
- b. The patient should be asked to breathe with his mouth open. This is to prevent sound being produced from a partially closed nose
- c. Avoid auscultation within 2-3 cm from the midline in the upper part of the chest, since breath sounds in these areas may normally have a bronchial character
- d. If the chest is hairy, moisten the chest wall with water and apply the chest piece tightly to avoid sounds produced by the friction with hair.

Auscultatory Areas

Anterior: From an area above the clavicle down to the 6th rib.

Axilla: Area upto the 8th rib.

Posterior: Above the level of the spine of the scapula down to the 11th rib.

Technique of Auscultation

- a. When abnormal breath sounds are heard, the extent to which the abnormal sound is heard should be



mapped from normal to abnormal zone. Note also the area at which the character changes.

- b. In case of patient with pleural pain, it is better to test vocal resonance and to avoid frequent deep breathing.
- c. Auscultation after coughing is a useful procedure. It helps differentiate coarse crepitation and low pitched rhonchi from pleural rub. Coughing does not alter pleural rub, but may alter the character of rhonchi and crackles.

Importance of Auscultation

- a. To assess the character and intensity of breath sounds
- b. Presence or absence of any added sounds
- c. Character of vocal resonance (voice sounds and whispering sounds)
- d. Miscellaneous sounds.

Breath Sounds

Breath sounds are produced by vibrations of the vocal cords due to turbulent flow of air.

Vesicular Breath Sound

It is low pitched, rustling in nature and is produced by attenuating and filtering effect of the lung parenchyma.

Duration of the inspiratory phase is longer than the expiratory phase in a ratio of 3 : 1.

There is no pause between the end of inspiration and the beginning of expiration.

Conditions with diminished vesicular breath sounds

- a. Bronchial asthma (silent chest)
- b. Tumour
- c. Pleural effusion (small)
- d. Pleural thickening
- e. Collapsed lung with occluded bronchus
- f. Emphysema.

Bronchial Breath Sound

It is produced by passage of air through the trachea and large bronchi, heard over an area of diseased, airless or consolidated lung interposed between the bronchi and chest wall.

Character: It is loud and high pitched, with an aspirate or guttural quality. The duration of inspiration is shortened whereas that of expiration is prolonged and sometimes the duration of inspiration and expiration are equal. There is a pause between inspiration and expiration.

Types of Bronchial Breathing

- a. Tubular
- b. Cavernous
- c. Amphoric.

Tubular

They are high pitched and present in:

- a. Pneumonic consolidation
- b. Collapsed lung or lobe when a large draining bronchus is patent
- c. Above the level of pleural effusion (in a partially collapsed lung with a patent bronchus).

Cavernous

They are low pitched and heard in the presence of thick-walled cavity with a communicating bronchus.

Amphoric

They are low pitched, with a high tone and a metallic quality and present in:

- a. Large superficial smooth-walled cavity
- b. Bronchopleural fistula
- c. Tension pneumothorax.

Absent Breath Sounds

- a. Pleural effusion (massive)
- b. Thickened pleura (fibrothorax)
- c. Collapsed lung or lobe when bronchus is occluded
- d. Pneumothorax
- e. Near fatal asthma (silent chest)
- f. Pneumonectomy
- g. Agenesis of lung.

Added Sounds

Crackles

They are non-musical, interrupted added sounds of short duration. They are explosive in nature.

Types

1. Fine—They are less loud, short in duration and arise from the alveoli
2. Coarse—They are low pitched, loud and arise from the bronchus and bronchioles.

Crackles may be:

- a. Early inspiratory as in chronic bronchitis
- b. Mid inspiratory as in bronchiectasis
- c. Late inspiratory as in asbestosis, pulmonary fibrosis, pneumonitis, interstitial lung disease, pulmonary oedema.



- d. Expiratory as in chronic bronchitis, pulmonary oedema.

Mechanism of Crackles

- Bubbling or flow of air through secretions in the bronchial level
- Sudden opening of successive bronchioles and alveoli with rapid equalisation of pressure causing a sequence of explosive sounds.

Crackles without sputum production indicates interstitial lung disease. Crackles with sputum production indicates parenchymal lung disease.

Fine localised crackles are a sign of parenchymal infiltration. If heard over the apices of the lungs, it may be an early sign of pulmonary tuberculosis.

Medium or coarse crackles are a sign of respiratory disorder.

Fine end inspiratory crackles over both lung bases may be an early sign of LVF.

Coarse crackles (death rattle) can occur as a terminal event in gross pulmonary edema.

Rhonchi

They are musical, continuous added sounds.

They may be low pitched (*sonorous*), arising from large airways or high pitched (*sibilant*), arising from small airways.

Types of Wheeze (Fig. 4.21)

Fixed monophonic wheeze: It is a single note of constant pitch, timing and site. It results from air passing through a localised narrowing of airway. It is seen in incomplete obstruction of principal or lobar bronchus, as in:

- Tumours
- Foreign body
- Bronchial stenosis
- Intrabronchial granuloma.

Random monophonic wheeze: It is a random single note, which is scattered, occurring in inspiration and expiration and varying in duration, site and pitch, e.g. bronchial asthma.

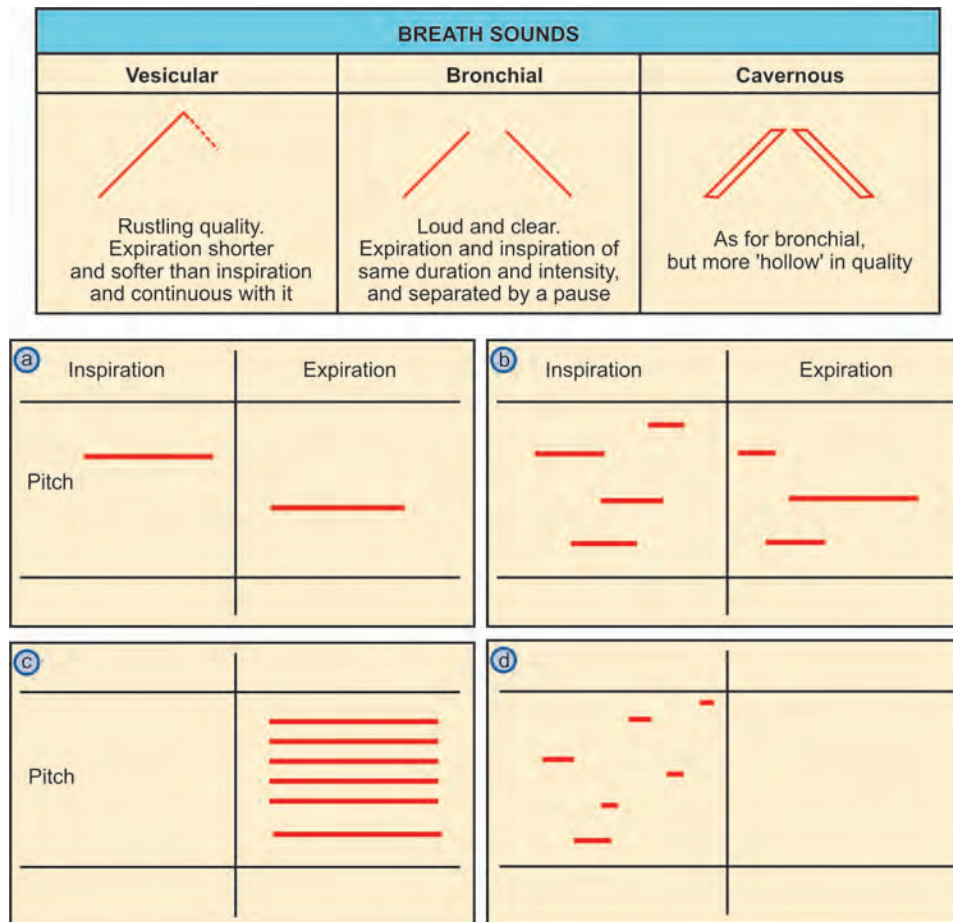

Fig. 4.21: Types of wheeze: (a) Fixed monophonic wheeze, (b) Random polyphonic wheeze, (c) Expiratory polyphonic wheeze, (d) Sequential inspiratory wheeze (squawks)



Expiratory polyphonic wheeze: This is a complex musical sound of multiple notes with all its components starting together, continuing to finally end in expiration due to expiratory compression of large central airways, e.g. emphysema.

Sequential inspiratory wheeze: It is due to the opening of distal airways which has become abnormally opposed during previous expiration, e.g. pulmonary fibrosis, fibrosing alveolitis, asbestosis.

Voice Sounds

Vocal Resonance

It is a voice sound heard with the chest piece of the stethoscope.

Types

- Bronchophony:** Voice sounds appear to be heard near the earpiece of stethoscope and words are unclear, e.g. consolidation, cavity communicating with a bronchus, above the level of pleural effusion. It is normally heard in proximity to the trachea.
- Aegophony:** Voice sound has a nasal or bleating quality. On saying 'E', it will be heard as 'A' (E to A sign), e.g. consolidation, above the level of pleural effusion, cavity.
- Whispering pectoriloquy:** The patient is asked to whisper words at the end of expiration, and this whispered voice is transmitted without distortion so that the individual syllables are recognised clearly, e.g. pneumonic consolidation.

Miscellaneous Sounds

Pleural rub: It is a superficial, localised squeaking or grating sound best heard with firm pressure of stethoscope. They are not altered by coughing. They are associated with pain.

Pleuro-pericardial rub: It is present in pleurisy adjacent to the pericardium. It is due to roughened pleural surface adjacent to the pericardium being moved across one another by cardiac pulsation.

Differentiation between Pleural Rub and Crackles

Rub	Crackle
a. Superficial and loud	Not superficial or loud
b. Continuous	Discontinuous
c. Localised	Heard over a wide area
d. Unaffected by cough	Intensified or abolished by cough
e. Pressure with stethoscope over the chest increases the sound	No effect
f. Associated with pain and tenderness	No pain or tenderness

Other Features of Clinical Significance

Heimlich's manoeuvre: Laryngeal obstruction by a foreign body in an adult can be dislodged by a sudden inward and upward forceful compression of the upper abdomen, by standing behind the patient.

Post-tussive suction: It is a sucking sound, heard over the chest wall during inspiration, following a bout of cough, over the area of amphoric breath sound. It occurs in the presence of thin-walled superficial, collapsible, communicating cavity.

Succussion splash: Splashing sound heard over the chest either with the stethoscope or unaided ear applied to the chest wall when the patient is shaken suddenly by the examiner (Fig. 4.22).

This is done by asking the patient to lie down laterally with the healthy side in the dependent position. Percuss and determine the air-fluid level in the paraspinal region and keep the stethoscope over that region. Then grasp the non-dependent shoulder and shake it suddenly, when a sound like that of splashing water can be heard (Fig. 4.23).



Fig. 4.22: Succussion splash



Fig. 4.23: Succussion splash—lateral decubitus position



Fig. 4.24: Right hydropneumothorax

Succession splash can be heard in hydropneumothorax (Fig. 4.24), diaphragmatic hernia. It is normally heard over the fundus of stomach filled with air and fluid.

Coin sound: It is the metallic quality of a coin sound produced on one side of the chest, that can be appreciated on the diametrically opposite side of the chest wall, by use of a stethoscope on that side. It is heard in tension pneumothorax and at the air fluid level of hydropneumothorax.

DeEspine's sign: It is the presence of high pitched tubular breathing and whispering pectoriloquy over the thoracic spine below T₃ in adults and T₄ in children and infants. It is due to transmission of bronchial breath sound through a mass or central pneumonia in the middle or posterior mediastinum.

Bronchial breath sounds may be heard normally over the midline in the back up to T₃ in adults and T₄ in children.

Others

Stridor

It may be laryngeal or tracheal in origin.

Laryngeal stridor: It is a high pitched, crowing sound better heard during inspiration, e.g. obstruction of the larynx by foreign body, laryngeal oedema.

Signs in Common Respiratory Disorders

Pathology	Mediastinal shift	Percussion note	Breath sounds	Vocal resonance	Added sounds
1. Consolidation	Midline	Dull	Tubular	Increased	Indux fine crackles Redux coarse crackles
2. Collapse due to					
a. Major bronchus obstruction	Same side	Dull	Diminished or absent	Reduced or absent	None
b. Peripheral bronchus obstruction	Same side	Dull	Tubular	Increased	None
3. Fibrosis	Same side	Impaired	Diminished or bronchial	Variable	None or fine crackles
4. Cavity	Midline or same side				
a. Thick-walled	(if associated	Impaired	Cavernous	Increased	Fine or coarse crackles
b. *Thin-walled	fibrosis present)	Impaired	Cavernous	Increased	Fine or coarse crackles
5. Bronchiectasis	Midline	Impaired	Vesicular or cavernous** or tubular***	Normal or increased	Persistent coarse leathery crackles
6. Pleural effusion or empyema	Opposite side	Stony dull	Diminished or absent (tubular above level of effusion)	Reduced or absent (increased above level of effusion)	Pleural rub may be heard above the level of effusion
7. Pneumothorax	Opposite side	Hyper-resonant	Diminished or absent (amphoric in valvular pneumothorax)	Reduced or absent (may be increased in valvular pneumothorax)	None
8. Bronchitis	Midline	Resonant	Vesicular	Normal	Rhonchi and crackles
9. Emphysema	Midline	Hyper-resonant	Diminished	Normal or decreased	Rhonchi may be heard
10. Bronchial asthma	Midline	Resonant	Vesicular with prolonged expiration	Normal	Inspiratory and expiratory rhonchi

* In thin-walled superficial, collapsible cavity, amphoric breath sound may be heard instead of cavernous breath sound.

** In bronchiectasis associated with large cystic cavities.

*** In bronchiectasis associated with surrounding consolidation.



Tracheal stridor: It is a low pitched sound best heard in inspiration.

Hamman's Mediastinal Crunch

It is clicking, rhythmical sound synchronous with the cardiac cycle, which may be heard with or without the aid of stethoscope, e.g. mediastinal emphysema.

Cavity

Cavity can be defined as a gas containing space within the lung surrounded by a wall whose thickness is > 1 mm.

A gas containing space possessing a wall of < 1 mm in thickness constitutes a *Bulla*.

Thick-walled Cavity

1. Lung abscess
2. Metastatic carcinoma
3. Bronchogenic carcinoma
4. Wegener's granulomatosis
5. Fungal cavity.

Thin-walled Cavity

1. Tuberculous cavity
2. Infected bullae
3. Post-traumatic cysts.

If thickness of wall of cavity is:

< 5 mm	Benign
5–15 mm	Benign or malignant
> 15 mm	Malignant

The nature of wall of cavity gives a clue to the underlying disorder:

1. Irregular or nodular—carcinoma
2. Shaggy—acute lung abscess
3. Smooth—in other cavitory lesions

Fibrosis

Types of Fibrosis

1. Focal, e.g. pneumoconiosis < 1 cm; if > 1 cm, consider progressive massive fibrosis (PMF)
2. Replacement, e.g. pulmonary TB, bronchiectasis
3. Interstitial, e.g. fibrosing alveolitis.

Upper Lobe Fibrosis

1. Pulmonary TB
2. Ankylosing spondylitis
3. Silicosis
4. Sarcoidosis

Differentiation between Active and Passive Collapse

Features	Active collapse	Passive collapse
Droop of shoulder; hollowing of supra- and infra-clavicular fossa	Present	Absent
Trachea	Pulled to same side	Pushed to opposite side
Percussion note	Dull	Subtympanic or skodiac resonance
Breath sounds	Absent	Tubular
VF/VR	Absent	Increased
Cause	Luminal or extraluminal obstruction	Pleural effusion, pneumothorax.

Differentiation between Fibrosis and Collapse

Features	Fibrosis	Collapse
1. Onset	Chronic	Sudden
2. Clubbing	Present	Absent
3. Percussion	Impaired	Dull
4. Breath sounds	Decreased	Absent
5. Added sounds	Crackles	None

5. Rheumatoid arthritis
6. Radiation.

Lower Lobe Fibrosis

1. Asbestosis
2. Fibrosing alveolitis
3. Bronchiectasis
4. Scleroderma
5. Loeffler's syndrome.



Investigations

Sputum Examination

In patients with symptom of cough with expectoration, sputum examination forms an important investigation. In patients who do not bring out sputum, inhalation of droplets of normal saline can bring about its production and help in its analysis.

Sputum should be initially examined macroscopically and the following characters to be noted:

- a. Quantity
- b. Consistency
- c. Colour
- d. Presence of blood
- e. Odour.



Sputum should then be subjected to the following examination:

- Gram's stain and acid fast stain
- Cytology including malignant cells
- Culture and sensitivity
- Presence of hyphae, Charcot-Leyden crystals, Curschmann's spirals, Creola bodies.

Lung Function Tests

These tests are done to assess the ventilatory capacity of the patient.

Bed Side Lung Function Tests

- Duration of expiratory airflow:* This is assessed by placing the diaphragm of the stethoscope over the trachea and asking the patient to breathe out after maximal inspiration. Normally the duration of the expiratory sound heard is 4 seconds. The duration of the expiratory sound heard over the trachea should not exceed 6 seconds. If the duration exceeds 6 seconds, it indicates obstructive pulmonary disease.
- Breath-holding test:* In this test, the patient's vital capacity is tested by asking the patient to take a deep inspiration, and then to count numbers while holding his breath. Normally, a patient can do this up to a count of 40.
- Snider's test:* It is a crude assessment of airway resistance. The patient is asked to blow out a candle in a single breath, with his mouth open, which is kept at a distance of 15 cm from the patient.

Spirometry

The spirometer is used to assess lung function. These tests are done to differentiate obstructive from restrictive lung disease. It is used to assess the initial disability and exercise tolerance, and to assess subsequent improvement with therapy.

Spirometry is the measure of airflow during inspiration and expiration. The test is performed in the sitting position and airflow is recorded as forced and sustained expiration followed by forced and sustained inspiration. Three efforts which have less than 5% variability between each other are selected and the best effort is used for interpretation.

Spirometry Measurements

Forced vital capacity (FVC)

Total volume of air expired with a maximal effort after deep inspiration.

Forced expiratory volume (FEV_1)

Volume of air expired in the first second after deep inspiration.

Maximal expiratory flow rate (MEFR)

Mid-portion of expiration (25–75 %)

Peak expiratory flow rate (PEFR)

Volume of air forcibly expired during first 10 seconds after deep inspiration.

All the above parameters are read as normal or abnormal, when compared to predicted values. Predicted values vary as per age, sex, height and ethnic group.

Obstructive abnormality

- $FEV_1\% = FEV_1 \text{ (observed)} / FEV_1 \text{ (Predicted)} = < 80\%$
- $FEV_1/FVC\% = FEV_1 \text{ (observed)} / FVC \text{ (observed)} = < 75\%$.

Restrictive abnormality

- $FVC\% = FVC \text{ (observed)} / FVC \text{ (Predicted)} = < 75\%$
- $FEV_1/FVC\% = FEV_1 \text{ (observed)} / FVC \text{ (observed)} = \text{Normal} (> 75\%)$.

The parameters assessed by spirometry are:

- Forced expiratory volume in one second (FEV_1)
- Forced vital capacity (FVC)
- Vital capacity (VC).

Patterns of Abnormal Ventilatory Capacity

Test	Obstructive lung disease	Restrictive lung disease
1. FEV_1	Markedly decreased	Decreased
2. VC	Decreased or normal	Decreased
3. FEV_1/VC (80%)	Decreased (70% to 75%)	Normal (> 75%)

Normal vital capacity

In men = 4.8 L

In women = 3.1 L

FEV_1 (Fraction of vital capacity expired in one sec) = 83% of vital capacity.

Lung Volume Estimation

Abnormalities of lung volume in obstructive and restrictive ventilatory defects can be assessed by (Fig. 4.25):

- Helium dilution technique
- Whole body plethysmography.

Peak Expiratory Flow Rate

This can be assessed at the bed side by using a peak expiratory flow rate meter for monitoring the severity

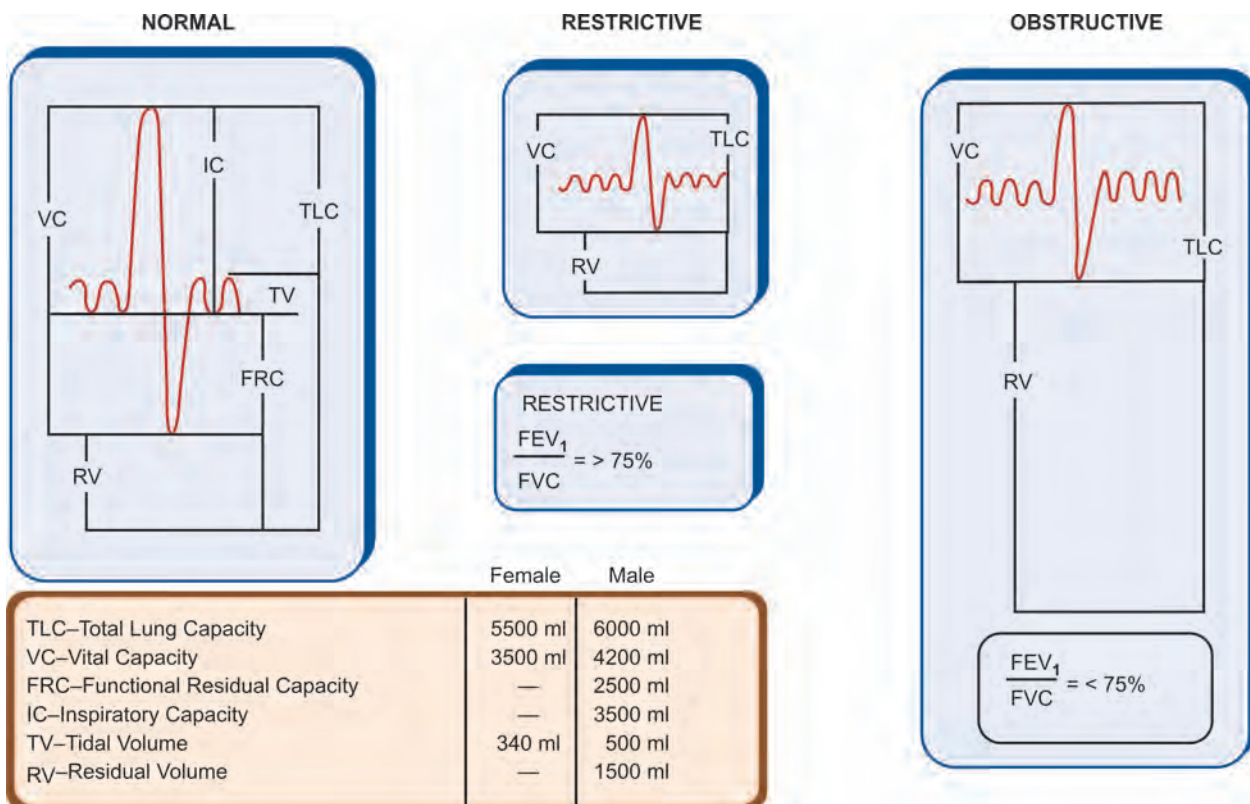

Fig. 4.25: Lung volumes (FEV₁—Fraction of vital capacity expired in first second)

of airway obstructive disease and their response to therapy. Results are compared with tables prepared on normal controls according to age, height, sex and race.

Chest X-ray

This is the single most important investigation in respiratory medicine and provides essential information concerning the underlying respiratory disease process in many patients. It is a mirror that manifests many systemic disorders.

Some patients may have serious or advanced respiratory disease with a normal chest X-ray. These conditions may be:

1. Bronchitis
2. Bronchial asthma
3. Bronchiectasis
4. Interstitial lung disease
5. Solitary or multiple pulmonary nodules of size < 0.5 mm.
6. Endobronchial TB
7. Bronchial adenoma
8. Right middle lobe collapse
9. Acute pleurisy

10. Pleural effusion (< 300 ml)
11. Miliary TB—cryptic miliary
12. Pulmonary embolism without infarction
13. Viral and mycoplasma pneumonia
14. Sarcoidosis
15. Allergic alveolitis
16. Connective tissue disorder—SLE
17. *Pneumocystis carinii* pneumonia.

In an apparently normal chest X-ray, look for the following:

1. A small apical pneumothorax
2. A fluid level behind the heart due to a hiatus hernia
3. Right middle lobe collapse with loss of clarity of the right heart border
4. Left lower lobe collapse with absence of the outline of the left diaphragm behind the heart (sail sign)
5. A deviated trachea
6. Paratracheal lymphadenopathy
7. Air beneath the diaphragm
8. Rib notching
9. Mastectomy
10. Dextrocardia with the film reversed.



11. Cervical ribs
12. Azygos lobe (It is formed by azygos vein that crosses the upper lobe of the right lung in a curved line resembling an inverted comma, to drain medially into the SVC. The part of the right lung above the impression formed by the azygos vein is known as the azygos lobe)
13. Achalasia—Chest X-ray air/fluid level behind the heart.

Some of the important and common chest X-ray findings and their differential diagnosis are discussed.



Causes of Bilateral Hilar Enlargement

1. Sarcoidosis
2. Lymphoma
3. Tuberculosis
4. Pulmonary hypertension
5. Pulmonary embolism
6. Septal defects (increased pulmonary flow)
7. Silicosis
8. Lymphangitis carcinomatosa.



Causes of Unilateral Hilar Enlargement

1. Bronchial carcinoma
2. Sarcoidosis
3. Lymphoma
4. Pulmonary embolism.

The left hilum may be up to 2 cm higher than the right.

Unilateral Hypertransradiant Hemithorax

1. Poor technique
2. Scoliosis (hypertransradiant hemithorax to side to which the patient is turned)
3. Mastectomy
4. Poliomyelitis (atrophy of pectoral muscles)
5. Poland's syndrome (unilateral congenital absence of pectoral muscles)
6. Pneumothorax
7. Compensatory emphysema
8. Obstructive emphysema
9. Unilateral bullae
10. Macleod's syndrome (late sequelae of childhood bronchiolitis)
11. Congenital lobar emphysema.

Hemithorax Opacity

- a. With no mediastinal shift
 1. Consolidation
 2. Pleural effusion (small)
 3. Mesothelioma.

- b. With mediastinal shift to opposite side
 1. Pleural effusion (moderate to large)
 2. Diaphragmatic hernia.
- c. With mediastinal shift to same side
 1. Collapse
 2. Post-pneumonectomy
 3. Lymphangitis carcinomatosa
 4. Pulmonary agenesis and hypoplasia.

Widespread Alveolar Opacities

1. Pulmonary oedema
2. Pneumonia (tuberculosis, histoplasmosis, *Pneumocystis carinii*, influenza, chickenpox, viral pneumonias, bronchopneumonia)
3. Haemorrhage (trauma, anticoagulants, haemophilia, leukaemia, DIC, Goodpasture's syndrome)
4. Fat emboli
5. Alveolar cell carcinoma
6. Haematogenous metastases
7. Lymphoma
8. Sarcoidosis.

Honeycomb Lung (Air Containing Cysts 0.5–2.0 cm in Diameter)

1. Collagen disorders (Rheumatoid lung, Scleroderma)
2. Extrinsic allergic alveolitis
3. Sarcoidosis
4. Pneumoconiosis
5. Cystic bronchiectasis
6. Cystic fibrosis
7. Drugs (nitrofurantoin, busulphan, cyclophosphamide, bleomycin and melphalan)
8. Histiocytosis X
9. Cryptogenic fibrosing alveolitis
10. Neurofibromatosis.

Miliary Mottling (0.5 to 2 mm Opacities)

1. Miliary tuberculosis
2. Fungal diseases (Miliary histoplasmosis, coccidioidomycosis, blastomycosis and cryptococcosis)
3. Coal miner's pneumoconiosis
4. Sarcoidosis
5. Acute extrinsic allergic alveolitis
6. Fibrosing alveolitis
7. Haemosiderosis
8. Silicosis
9. Pulmonary eosinophilic syndrome
10. Pulmonary alveolar proteinosis
11. Lymphangitis carcinomatosa

Causes of Solitary Pulmonary Nodule

Inflammatory (50%)	Malignant (40%)	Benign (5%)	Others (5%)
Tuberculoma	Bronchogenic carcinoma	Hamartoma	Hydatid cyst
Histoplasmosis	Alveolar cell tumours	Chondroma	Ascariasis
Coccidioidoma	Solitary metastasis	Fibroma	Mycetoma
Cryptococcosis	Bronchial adenoma	Lipoma	Infarct
Actinomycosis	Lymphoma	Myxoma	AV malformation
Nocardiosis	Sarcoma	Endometriosis	Amyloidosis
Non-specific granuloma		Neurogenic tumours	Mucoid impaction
Lipoid pneumonia			Dermoid cyst
Chronic lung abscess			

Features of Benign and Malignant Solitary Pulmonary Nodule

Clinical features	Types of nodule		
	Benign	Primary malignancy	Solitary metastasis
Age	Under 35 years	Over 35 years	Any
Size of SPN	Tendency to be smaller	Tendency to be larger	Either
Margin	Sharp	Ill-defined	Sharp
Calcification	Frequent	Rare	Rare
Doubling time	Less than 30 days or More than 500 days	30 to 500 days	30 to 500 days
History of smoking	Not related	Strong relation	Not related
Extrapulmonary malignancy	Not usually	Not usually	Usually

Solitary Pulmonary Nodule (Fig. 4.26)

This is defined as a spherical intrapulmonary roentgenographic density of < 3 cm in diameter. Pulmonary nodules of size > 3 cm are called mass lesions.

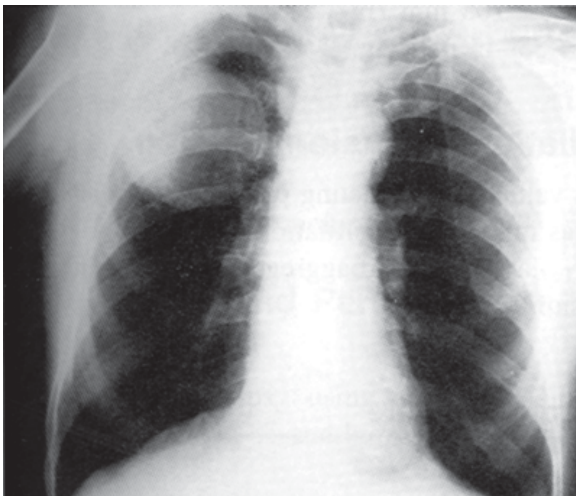

Fig. 4.26: Solitary pulmonary nodule

Multiple Medium Sized Pulmonary Nodules (5-10 mm)

1. Metastasis (breast, thyroid, kidney, GIT, testes)
2. Abscesses (*Staphylococcus aureus*)

3. Coccidioidomycosis
4. Histoplasmosis
5. Sarcoidosis
6. Wegener's granulomatosis
7. Rheumatoid nodules
8. Caplan's syndrome (rheumatoid arthritis with pneumoconiosis)
9. Silicosis.

Lung Cavities (Fig. 4.27)

1. *Staphylococcus aureus* (thin-walled and multiple)
2. *Klebsiella pneumoniae* (thick-walled and with ragged inner lining, common in upper lobes)
3. Tuberculosis (thin-walled and smooth, common in upper lobes)
4. Aspiration
5. Aspergillosis
6. Hydatid cyst
7. Carcinoma of the bronchus (thick-walled; predilection for the upper lobes; cavitation common in squamous cell carcinomas)
8. Metastases (thin or thick-walled; seen especially in secondaries from a squamous cell carcinoma, carcinoma colon and from a sarcoma)
9. Pulmonary infarction
10. Cystic bronchiectasis (thin-walled; common in lower lobes)

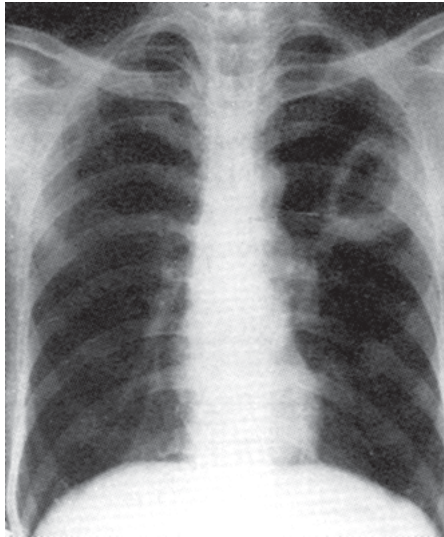

Fig. 4.27: Left midzone—thick-walled, irregular cavity

11. Infected emphysematous bulla (thin-walled with air fluid level)
12. Bronchogenic cyst
13. Wegener's granulomatosis (thick-walled)
14. Rheumatoid nodules.
15. Traumatic lung cyst (thin-walled and peripheral).

Unilateral Elevated Hemidiaphragm

1. Phrenic nerve palsy
2. Pulmonary collapse
3. Pulmonary infarction
4. Chronic pleural disease (fibrothorax)
5. Eventration of the diaphragm
6. Gaseous distension of the stomach or splenic flexure
7. Subphrenic inflammatory disease (subphrenic abscess, subpulmonic effusion)
8. Scoliosis (the raised hemidiaphragm is on the side of the concavity)
9. Massive hepatomegaly or splenomegaly.

Bilateral Elevated Hemidiaphragm

1. Poor inspiratory effort
2. Obesity
3. Bilateral basal pulmonary collapse
4. Small lungs (fibrotic lung disease)
5. Ascites
6. Pregnancy
7. Pneumoperitoneum
8. Hepatosplenomegaly
9. Large intra-abdominal tumour
10. Bilateral subphrenic abscesses
11. Bilateral subpulmonary effusions.

CT Scan

- Valuable in determining the size and position of pulmonary nodules (< 0.5 mm size) or mass and also whether calcification or cavitation is present.
- CT guided percutaneous transthoracic needle biopsy of the lung can be done.
- To obtain cytological diagnosis of peripheral lung lesion.
- Very useful in studying mediastinal pathology
- High resolution CT scan useful in diagnosing interstitial fibrosis and bronchiectasis.

Ultrasound Scan

This is useful in diagnosing pleural pathology (pleural effusion, pleural tumours).

It is useful in diagnosis of subpulmonic effusion and presence of any subphrenic pathology like amoebic liver abscess.

It helps differentiate pleural effusion from basal consolidation.

MRI Scan

This modality of investigation is particularly useful in assessment of mediastinal vascular pathology.

Gas Diffusion Capacity

This is estimated by measuring the uptake of carbon monoxide from a single breath of 0.3% mixture in air. It estimates the ability of the lungs to exchange gases and is useful in diagnosing ILD and emphysema.

Arterial Blood Gas Analysis

Measurement of PO_2 , PCO_2 , and HCO_3^- concentration is done.

This is particularly useful in management of respiratory failure, asthma and ARDS.

Ear or pulse oximeter allows continuous non-invasive measurement of arterial oxygen saturation.

Normal values are:

pH = 7.35–7.45

PaO_2 = 80–105 mm Hg

PCO_2 = 35–45 mm Hg.

Ventilation-Perfusion Imaging

This is valuable in detecting pulmonary thromboembolism. ^{133}Xe gas inhalation (ventilation scan).

^{99m}Tc labelled macroaggregates of albumin injected IV (perfusion imaging).



Types and Causes of Respiratory Failure

Type I		Type II	
Acute	Chronic	Acute	Chronic
PaO ₂ ↓↓	PaO ₂ ↓	PaO ₂ ↓	PaO ₂ ↓
PaCO ₂ ↔	PaCO ₂ ↔	PaCO ₂ ↑	PaCO ₂ ↑
pH ↔	pH ↔	pH ↓	pH ↓ or ↔
HCO ₃ ↔	HCO ₃ ↔	HCO ₃ ↔	HCO ₃ ↑
<i>Examples</i>			
Asthma	Emphysema 'pink puffer'	Acute epiglottitis	Chronic bronchitis 'blue bloater'
Pulmonary oedema	Lymphatic carcinomatosis	Severe acute asthma	Primary alveolar hypoventilation
Pulmonary embolus		Respiratory muscle paralysis	
ARDS			
Pulmonary fibrosis			

Pulmonary Angiography

It is a definitive method of diagnosing pulmonary emboli.

Bronchoscopy

Bronchoscopes are of two types:

- Rigid bronchoscope
- Fibre optic bronchoscope (flexible).

Uses of Bronchoscope

- To detect structural changes (distortion or obstruction of trachea and larger bronchi)
- Detection of intrabronchial lesions (bronchial adenoma, endobronchial TB)
- Biopsy of abnormal tissue in the bronchial lumen or wall
- Transbronchial lung biopsy
- Bronchial brushing, washing or aspirates for cytological or bacteriological examination
- Detection and removal of foreign body
- Haemoptysis with normal chest X-ray (diagnostic and therapeutic).

Rigid Bronchoscope

- Can be used to examine the trachea and major bronchi
- Used to remove foreign body in the large airways
- Used for control of active, massive haemoptysis by tamponading of endobronchial bleeding either with the instrument itself or by using a Fogarty catheter.

Fibre-optic Bronchoscope

- Can be used to study peripheral bronchi
- Transbronchial lung biopsy
- Detection of unexplained haemoptysis.

Pleural Aspiration and Percutaneous Pleural Biopsy

Pleural aspiration and biopsy using an Abram's needle provides biochemical, cellular and histological evidence of cause of pleural disease.

Oxygen Therapy

The aim is to facilitate adequate uptake of oxygen into the blood to meet the demands of peripheral tissues.

Nasal Prongs

It allows patients to eat, drink, speak during therapy. In this method, the exact FIO₂ delivered is not known. Flow rates should be limited to < 5 L/minute. Flow rate of 1 L/minute by this method delivers FIO₂ of 24% and each additional liter of flow increases the FIO₂ by 4%.

Venturi Masks

It permits precise delivery of oxygen. Usual FIO₂ delivered by this method are 24%, 28%, 31%, 35%, 40% and 50%. This type of delivery is useful in COPD and hypercapnia because one can titrate the PaO₂ to minimise CO₂ retention.

Non-rebreathing Masks

A one-way valve prevents exhaled gases from entering the reservoir bag and is useful to achieve higher O₂ concentration and FIO₂.

CPAP Mask

Continuous positive airway pressure mask can be used if the PaO₂ is less than 60 mm of Hg during the use of non-rebreathing mask. CPAP is delivered by a tight fitting mask equipped with pressure-limiting valves.



Bilevel Positive Airway Pressure (BiPAP)

It is a method of non-invasive ventilation where pressure is applied during inspiration and expiration by a mask. The inspiratory support decreases the patient's work of breathing and the expiratory support (CPAP) improves gas exchange by preventing alveolar collapse. This method is very useful in neuromuscular disease, COPD and post-operative respiratory insufficiency and decreases the need for endotracheal intubation and mechanical ventilation.

Respiratory Diseases

Classification of Respiratory Diseases

Obstructive Diseases

- Bronchial asthma
- Chronic obstructive lung disease
- Bronchiectasis
- Cystic fibrosis
- Bronchiolitis.

Restrictive Diseases (PAINT)

- Pleural disease
- Alveolar
- Interstitial lung diseases
- Neuromuscular diseases.
 - Diaphragmatic paralysis
 - Myasthenia gravis
 - Guillain-Barré syndrome
 - Muscular dystrophies
 - Cervical spine injury
- Thoracic cage abnormalities
 - Kyphoscoliosis
 - Obesity
 - Ankylosing spondylitis.

Bronchial Asthma

Asthma is an inflammatory disease of the small airways, characterised by episodic, reversible bronchial obstruction due to hyper-responsiveness of tracheo-bronchial tree to a multiplicity of intrinsic and extrinsic stimuli manifested clinically by paroxysms of polyphonic wheeze, dyspnoea, and cough which may be relieved spontaneously or as a result of therapy.

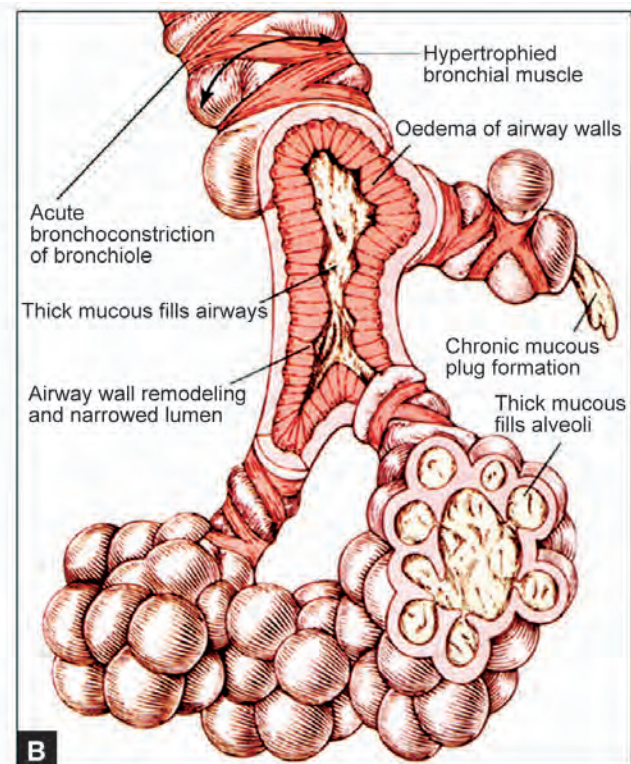
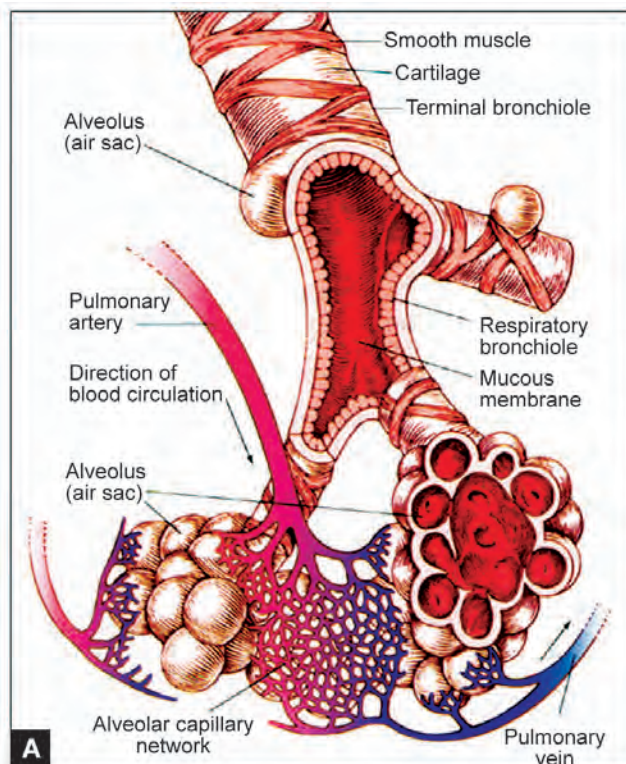

Figs 4.28A and B: (A) Normal anatomy terminal bronchiole, (B) Airflow obstruction during asthmatic episode



Types

Extrinsic Asthma (Atopic Asthma, Early Onset Asthma)

Onset is in childhood. It occurs in atopic individuals who readily form IgE antibodies in response to allergens. Atopic patients can be identified by skin sensitivity tests. Asthmatic inflammatory reaction is characterised by a cellular infiltrate rich in eosinophils.

Intrinsic Asthma (Non-atopic Asthma, Late Onset Asthma)

It can begin at any age, especially in late adulthood. There is no role for allergens in the production of the disease.

Factors Precipitating Asthma

- Cold air
- Tobacco smoke
- Dust, acrid fumes
- Emotional stress
- Respiratory infections (viral, bacterial)
- Exercise
- Drugs
 - i. NSAIDs especially *aspirin
 - ii. β -blockers

Note: *In aspirin sensitive asthma, patients have a triad of asthma, nasal polyps and aspirin sensitivity and it can be life threatening.

Acetaminophen, sodium salicylate, choline salicylate, salicylamide and propoxyphene are well-tolerated.

- Chemicals

Sulfiting agents like Na or K bisulfite, sulphur dioxide, etc.
- Allergens
 - a. Ingested (fish, nuts, strawberries)
 - b. Inhaled (dust, pollen, house dust mite)
 - c. Food additives (tartrazine, metabisulfite preservatives, monosodium glutamate or ajinomoto)
 - d. Occupational allergens (grain-dust, wood-dust).

Mechanism Involved in Asthma

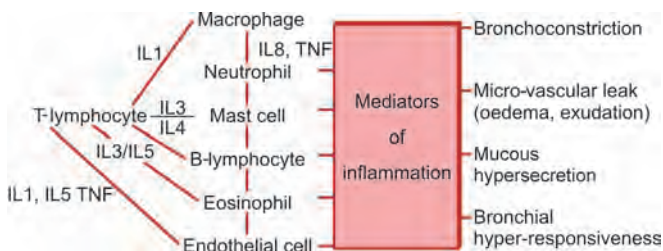

Pathophysiology (Fig. 4.28B)

- Chronic airway inflammation as evidenced by cellular infiltration of airway by activated eosinophils, mast cells, macrophages and T-lymphocytes
- Released mediators from the above cells cause bronchial smooth muscle contraction
- Denudation and desquamation of the epithelium forming mucous plugs that obstruct the airway
- Airway remodelling as evidenced by
 1. Smooth muscle hypertrophy and hyperplasia
 2. Goblet cell and sub-mucosal gland hypertrophy leading to mucous hypersecretion
 3. Collagen deposition causing thickening of lamina reticularis
 4. Cellular infiltration, oedema and possible airway wall thickening



Clinical Features

- Widespread, polyphonic, high pitched wheezes are heard.
- Expiratory wheeze is heard with mild bronchoconstriction.
- Inspiratory and expiratory wheezes are heard in moderate bronchoconstriction.
- Inspiratory wheeze is heard in severe bronchoconstriction.
- In near fatal asthma, the chest is silent.

All wheezes are not due to asthma. Other disorders that can produce wheeze are:

 1. Tuberculosis
 2. Cardiac asthma
 3. COPD
 4. Allergic bronchopulmonary aspergillosis (ABPA) (asthma responding poorly to therapy, opacities in chest X-ray, peripheral eosinophilia, high IgE more than 2000 ng/ml, IgM antibodies to aspergillus with proximal cystic bronchiectasis)
 5. Carcinoid tumours
 6. Eosinophilic pneumonias
 7. Systemic vasculitis
 8. Recurrent pulmonary emboli.

Nocturnal Asthma

- Nocturnal asthma is defined as an overnight fall of more than 20% in the FEV₁ or PEF_R. It may be the sole manifestation of asthma. This is presumed to be due to:
- a. Early morning fall in circulating adrenaline
 - b. Overnight changes in vagal tone (increased vagal tone in early morning)
 - c. Airway cooling at night



- d. Circadian changes in plasma cortisol concentration (midnight to early morning fall in cortisol level).

Gastric Asthma

Worsening of asthma after meals or dyspnoea occurring only after meals is due to gastro-oesophageal reflux (reflux-reflex). This is treated by avoiding oral bronchodilators and instituting anti-reflux therapy.

Exercise-induced Asthma

Asthma is induced by exercise and inhaled bronchodilators should be given before exercise. Usual therapy with pre-exercise bronchodilators or sodium cromoglycate are advised.

Episodic Asthma

Patient has no respiratory symptoms between episodes of asthma.

Chronic Asthma

Symptoms may be chronic unless controlled by appropriate therapy. It may simulate chronic bronchitis.

Acute Severe Asthma (Status Asthmaticus)

It is a medical emergency. Patient is hypoxic and cyanosed due to severe bronchospasm. It is characterised by tachycardia (pulse rate > 120), tachypnoea (respiratory rate $> 30/\text{min}$), sweating, pulsus paradoxus (> 10 abnormal; > 20 , profound obstruction), altered level of consciousness, and an inspiration-expiration ratio of 1 : 3 or 1 : 4.

Life Threatening Features

1. Patient cannot speak
2. Central cyanosis
3. Exhaustion, confusion, altered consciousness
4. Bradycardia
5. Silent chest
6. Unrecordable peak flow
7. Severe hypoxaemia (< 8 kPa)
8. A normal or high CO_2 tension (5–6 kPa)
9. A low pH or high $[\text{H}^+]$.



Investigations

Chest X-ray

Chest X-ray should be taken to rule out other causes of wheezing and also to rule out the presence of pneumothorax in all cases of severe acute asthma.

Pulmonary Function Tests (PFT)

PFT shows obstructive type of lung disease.

FEV_1 following 2 puffs of beta agonist shows an increase by 15% or greater than the previous level.

Peak Expiratory Flow (PEF)

Serial recordings of PEF may show overnight fall (morning dip) and subsequent rise during the day in patients with asthma.

There are increased eosinophils in sputum and blood. Serum IgE is elevated in atopic asthma.



Differential Diagnosis of Asthma

1. Chronic bronchitis
2. Emphysema
3. Cystic fibrosis
4. Viral bronchiolitis
5. Bronchial stenosis
6. Mechanical airway obstruction
7. Foreign body aspiration
8. Endobronchial tumour
9. Cardiac failure
10. Superior vena cava syndrome
11. Substernal thyroid
12. Vocal cord dysfunction
13. Pulmonary embolism
14. Pulmonary eosinophililia
15. Drugs – ACEI, β -blockers
16. Systemic vasculitis
17. Carcinoid syndrome
18. Allergic bronchopulmonary aspergillosis



Management of Bronchial Asthma

1. Treatment of infection
2. Avoidance of allergens and other precipitating factors
3. Drugs
4. Hyposensitisation.

Drugs Used in Asthma

A. Drugs used for prevention of asthma

Sodium cromoglycate: This acts by preventing mediator release from mast cells. It is useful in children with atopic asthma and should be given for at least four weeks in a dose of 20 mg through a 'Spinhaler' or 5–10 mg from a metered dose inhaler 4 times daily.

Nedocromil sodium: This is an anti-inflammatory drug with similar properties to those of sodium cromoglycate.



Administered by a metered dose inhaler in a dose of 4 mg, 2 or 4 times daily.

Ketotifen: This is less effective than the above two drugs and causes profound drowsiness. The recommended dose is 1–2 mg twice daily with food.

B. Drugs used to reverse bronchospasm

β-Adrenergic Agonists

Short duration

- Ephinephrine
- Isoetharine
- Isoproterenol

Intermediate duration

- Metaproterenol
- Terbutaline
- Albuterol
- Pirbuterol
- Bitolterol
- Fenoterol

Long duration

- Salmeterol
- Formoterol

Inhaled Glucocorticoids

	Dose/mcg/puff
• Beclomethasone dipropionate	42
• Triamcinolone acetonide	100
• Flunisolide	250
• Budesonide	200
• Fluticasone propionate	44, 110, 220

1. *Adrenergic stimulants*: The drugs under this category are:

1. Catecholamines (epinephrine, isoproterenol, isoetharine, rimiterol and hexoprenaline).
2. Resorcinols (metaproterenol, terbutaline and fenoterol).
3. Saligenine (salbutamol).
4. Salmeterol 50-100 µg BD
Formoterol 12-24 µg BD
Bambuterol 10-20 mg OD

These are long acting selective β₂ agonist with long duration of action, preferably used along with inhaled corticosteroids.

They produce airway dilatation through stimulation of beta receptors by stimulating adenylyl cyclase enzyme with the resultant formation of cyclic AMP from ATP.

Catecholamines: These are short acting drugs, most effective by parenteral or inhalational routes. Epinephrine (0.3–0.5 ml of 1 : 1000 solution subcutaneously) and isoproterenol are non-β₂ selective and hence have

additional positive chronotropic and inotropic effects on the heart. Epinephrine has alpha stimulating effect whereas isoproterenol does not stimulate alpha receptors and is the most preferred drug of this group.

Resorcinols: Terbutaline 5 mg three times daily orally or by MDI.

Saligenines: Salbutamol 2 to 4 mg three times daily orally or by MDI.

2. *Anti-cholinergics*: Ipratropium bromide by MDI. This drug is especially useful in drug induced asthma, e.g. β-blockers.

3. *Methyl xanthines*

- a. Oral theophylline
- b. IV aminophylline (In children 9–16 years and adult smokers—a loading dose of 6 mg/kg followed by an infusion of 1 mg/kg/hr for 12 hours and 0.8 mg/kg/hr thereafter. In non-smokers— same loading dose if patient has not received the drug previously, followed by 0.1–0.5 mg/kg/hr as an infusion).

Theophylline has got a narrow therapeutic window. Ideal serum level is 10–20 µg/ml; if the serum level exceeds 30 µg/ml, seizures, arrhythmias may occur.

Theophylline clearance is decreased in the following conditions:

1. Concurrent use of erythromycin, cimetidine, allopurinol, or propranolol
2. Febrile illness
3. Neonates and elderly
4. Acute and chronic liver disease.

Theophylline clearance is increased in the following conditions:

1. Concurrent use of phenytoin, phenobarbitone
2. Cigarette smoking
3. In children.

C. Anti-inflammatory drugs

- a. Beclomethasone dipropionate (200 µg), twice daily by MDI
- b. Budesonide (200 µg), twice daily by MDI
- c. Oral prednisolone.
- d. Methyl prednisolone IV 125 mg stat, followed by 40-60 mg IV 6th hourly which corresponds to an equivalent dose of 60 mg prednisolone 6-8 hourly.
- e. Fluticasone—For prophylaxis 250 mcg BD (inhalation by puffs). Can be increased upto 1000 µg.
- f. Fluticasone and salmeterol combination.

D. Leukotriene antagonists.

- a. Montelukast (10 mg QID)



b. Zafirlukast (20 mg BD)

They provide effective control of mild persistent asthma and less effective when compared to inhaled corticosteroids.

E. *5-Lipoxygenase inhibitor.*

Zileuton 600 mg qid is primarily reserved for severe asthma. It causes elevation of liver enzymes. Monthly estimation of ALT is essential.

F. *Anti-IgE therapy:* Omalizumab is a monoclonal antibody against IgE and has a role in the management of moderate and severe persistent asthma. As add-on therapy, this drug is useful to reduce the dose of oral and inhaled steroids without a decline in quality of asthma control. Omalizumab 30-700 IU/mL SC based upon the patient's baseline IgE level.

G. *Alternative medications:* Methotrexate, cyclosporine, tacrolimus, and mycophenolate mofetil have been tried.



Management of Asthma

Classification of Severity

	Symptoms	Night-time symptoms	PEF
<i>Step 1</i> Intermittent	< 1 time a week Asymptomatic and normal PEF between attacks	≤ 2 times a month	≥ 80% predicted. Variability < 20%
<i>Step 2</i> Mild persistent	≥ 1 time a week but < 1 time a day	> 2 times a month	≥ 80% predicted Variability 20-30%
<i>Step 3</i> Moderate persistent	Daily Use β ₂ agonist daily Attacks affect activity	> 1 time a week	> 60% < 80% predicted. Variability > 30%
<i>Step 4</i> Severe persistent	Continuous Limited physical activity	Frequent	≤ 60% predicted Variability >30%



Treatment

	Long-term preventive	Quick relief
<i>Step 1</i> Intermittent	None needed	<ol style="list-style-type: none"> Short acting bronchodilator: inhaled β₂ agonist as needed for symptoms, but less than once a week Intensity of treatment will depend on severity of attack Inhaled β₂ agonist or cromoglycate before exercise or exposure to allergen
<i>Step 2</i> Mild persistent	Daily medication: <ol style="list-style-type: none"> Either inhaled corticosteroid, 200-500 μg, cromoglycate, nedocromil or sustained release theophylline If needed, increase inhaled corticosteroids up to 800 μg Either long acting inhaled β₂ agonist or sustained release theophylline or long acting β₂ agonist tablets can be added 	<ol style="list-style-type: none"> Short acting bronchodilator: inhaled β₂ agonist as needed for symptoms, not to exceed 3-4 times in one day
<i>Step 3</i> Moderate persistent	Daily medication: <ol style="list-style-type: none"> Inhaled corticosteroid 800-2000 μg and if needed Long acting bronchodilator: Either long acting inhaled β₂ agonist or sustained release theophylline or long acting β₂ agonist tablets can be added 	<ol style="list-style-type: none"> Short acting bronchodilator: inhaled β₂ agonist as needed for symptoms, not to exceed 3-4 times in one day
<i>Step 4</i> Severe persistent	Daily medication: <ol style="list-style-type: none"> Inhaled corticosteroid 800-2000 μg or more and Long acting bronchodilator: Either long acting inhaled β₂ agonist or sustained release theophylline or long acting β₂ agonist tablets added Corticosteroid tablet long-term 	<ol style="list-style-type: none"> Short acting bronchodilator: inhaled β₂ agonist as needed for symptoms

Step down: Review treatment in every 3-6 months. If control is sustained for 3 months step-wise reduction in treatment has to be done.

Step up: If control is not achieved, consider step up.



The presence of one of the features of severity is sufficient to place a patient in that category.



Management of Nocturnal Asthma

- Treatment with anti-inflammatory drugs (corticosteroids)
- Sustained-release theophylline or a β_2 agonist or both
- Long acting β_2 agonists.



Management of Acute Severe Asthma

- High concentration oxygen therapy
- High dose β_2 agonists by nebuliser
- Systemic corticosteroids
- If no response with above treatment, ipratropium bromide by nebuliser or IV aminophylline (250 mg over 20 minutes) or IV β_2 agonists
- Monitor treatment with pulse oximetry
- Assisted ventilation when needed
- Treatment with 70-80% helium (balanced oxygen) may be beneficial. This gas mixture reduces airway resistance and improves the effect of aerosolised bronchodilators.

Indications for Assisted Ventilation

- Coma
- Respiratory arrest
- Exhaustion, confusion, drowsiness
- Deterioration of ABG tensions despite therapy

PaO ₂	< 8 kPa and falling (60 mm Hg)
PaCO ₂	> 6.5 kPa and rising (50 mm Hg)
pH	< 7.3 and falling.

Obstructive Sleep Apnoea-Hypopnoea Syndrome (OSAHS)

- Apnoea (cessation of breathing) or hypopnoea (shallow breathing >30% reduction in baseline airflow associated with 4% decrease in oxygen saturation) followed by excessive daytime somnolence
- 2-4% of middle aged adults have OSAHS
- Loud-snoring is the most common symptom of OSAHS
- Morning headaches, intellectual deterioration, loss of libido, nocturnal arousals, nocturia, enuresis and chronic fatigue are common symptoms

- Obesity and nasal obstruction are common
- Apnoea may be central, obstructive or a combination of both (Airflow and respiratory effort absent in central type where as in obstructive type airflow is reduced or absent but the respiratory effort is intact)
- Overnight polysomnography (PSG or sleep study) – the gold standard for the diagnosis of OSAHS
- Sleep study includes EEG, EMG, electro-oculography, ECG and oxyhaemoglobin saturation along with assessment of respiratory airflow and effort

Indications for Sleep Study

- Snoring with excessive daytime sleepiness
- Titration of optimal nasal CPAP therapy
- Unexplained pulmonary hypertension
- Unexplained polycythaemia
- Daytime hypercapnia
- Poorly controlled hypertension

Apnoea-hypopnoea Index (AHI)

(Number of episodes per hour of sleep)

AHI is used to quantify the severity of OSAHS—Mild (5-15), moderate (16-30), severe (> 30)



Complications

- Hypoxaemia and hypercapnia
- Polycythaemia and COPD
- Cor pulmonale
- Systemic HTN, heart failure and stroke



Management

- Mild OSAHS – oral appliances like mandibular repositioning device
- Oxygen supplementation should be used when needed
- Positive airway pressure
CPAP is used to deliver air via a nasal or oral mask
BiPOP- Bilevel positive airway pressure can also be used but more expensive than CPAP
- Tracheostomy is indicated in life threatening significant alveolar hypoventilation.
- Uvulopalatopharyngoplasty is the most common surgical treatment
- Genioglossus advancement, hyoid myotomy with suspension and maxillo-mandibular advancement are other surgical procedures.



Chronic Obstructive Pulmonary Disease (COPD)

COPD is a disease state characterised by expiratory airflow limitation that is not fully reversible. The airflow limitation is usually both progressive and associated with an abnormal inflammatory response of the lungs to noxious particles or gases (Fig. 4.29).

A diagnosis of COPD should be considered in any patient who has symptoms of cough, sputum production, or dyspnoea, and or a history of exposure to risk factors for the disease. COPD includes chronic bronchitis and emphysema. The diagnosis is confirmed by spirometry. The presence of a post-bronchodilator $FEV_1 < 80\%$ of the predicted value in combination with an $FEV_1/FVC < 70\%$ confirms the presence of airflow limitation that is not fully reversible. A low peak flow is consistent with COPD, but it has poor specificity since it can be caused by other lung diseases.

Chronic Bronchitis

This is a condition associated with excessive tracheo-bronchial mucous production sufficient to cause cough with expectoration on most days for at least 3 months a year for more than two consecutive years. It can be subdivided into:

- a. Simple chronic bronchitis (describes a condition with mucoid sputum production).



Fig. 4.29: Pursed lip breathing—COPD

- b. Chronic mucopurulent bronchitis (persistent or recurrent purulent sputum production in the absence of local suppurative disease).
- c. Chronic bronchitis with obstruction/chronic asthmatic bronchitis (severe dyspnoea and wheezing in association with inhaled irritants or infections in the setting of bronchitis).

Emphysema

It is defined as distention of the air spaces distal to the terminal bronchiole with destruction of alveolar septa.

Predisposing Factors for COPD

1. Smoking
2. Environmental pollution (dust, smoke)
3. Genetic predisposition
4. Infection (bacterial or viral)
5. α_1 antitrypsin deficiency (for emphysema)
6. Occupational exposure (fumes, etc.)
7. Exposure to dampness, fog and sudden change in temperature.

Pathogenesis

COPD is characterised by chronic inflammation throughout the airways, parenchyma, and pulmonary vasculature. Macrophages, T-lymphocytes (CD8+), and neutrophils are increased in various parts of the lung. Activated inflammatory cells release a variety of mediators—leukotriene B₄ (LTB₄), interleukin 8 (IL-8), tumour necrosis factor α (TNF- α), and others capable of damaging lung structures. In addition to inflammation, an imbalance between proteinases and antiproteinases and oxidative stress play a role in the pathogenesis of COPD.

Protease—Antiprotease hypothesis holds that destruction of alveolar walls in emphysema is due to an imbalance between proteases and their inhibitors in the lung.

In α_1 -antitrypsin deficiency (a major protease inhibitor), emphysema develops at a younger age especially in smokers.

Impaction of smoke particles in bronchioles leads to inflammatory cell aggregation, increased elastase and decreased α_1 -antitrypsin resulting in centriacinar emphysema seen in smokers.

Types of Emphysema (Fig. 4.30)

Centriacinar Emphysema: There is destruction and enlargement of central or proximal part of respiratory

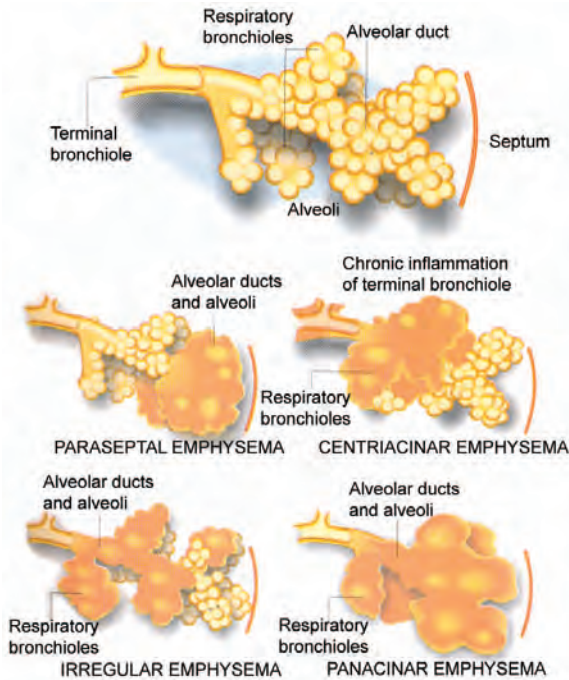

Fig. 4.30: Types of emphysema

unit—the acinus. There is predominant involvement of upper lobe and apices. It is commonly seen in male smokers in association with chronic bronchitis.

Panacinar Emphysema: There is uniform destruction and enlargement of acinus. It is predominant in lower basal zones. It is associated with α_1 -antitrypsin deficiency.

Paraseptal Emphysema: This involves only the distal acinus. It is found near the pleura and often causes spontaneous pneumothorax.

Irregular: There may be any type of involvement.

Special Varieties of Emphysema

Compensatory Emphysema: Normal lung tissue undergoes hyperinflation as a compensatory mechanism, in response to the damage occurring in part of the same lung or opposite lung. Here, alveolar septae are preserved.

Mediastinal Emphysema: This occurs as a result of escape of air rapidly into the mediastinum following rupture of overdistended alveoli. It may occur in the following conditions.

- Severe bronchial asthma
- Rupture of emphysematous bullae
- Rupture of oesophagus.

The escaped air tracks up into the subcutaneous tissues of the neck, manifesting as *subcutaneous emphysema*.

Differentiating Features between Emphysema and Chronic Bronchitis

Features	Predominant Emphysema (Pink Puffer)	Predominant Bronchitis (Blue Bloater)
1. Age of onset	6th decade	5th decade
2. Cough	After dyspnoea	Before dyspnoea
3. Dyspnoea	Severe	Mild
4. Sputum	Scanty, mucoid	Copious, purulent
5. Infections	Less common	Common
6. Respiratory insufficiency	Often terminal	Repeated attacks
7. Chest X-ray	Hyperinflation \pm bullous changes; small heart	Increased broncho-vascular markings; large heart
8. PaCO ₂ (mm Hg)	35–40	50–60
9. PaO ₂ (mm Hg)	65–75	45–60
10. Pulmonary hypertension	Mild	Moderate to severe
11. Cor pulmonale	Preterminal stage	Common
12. Diffusing capacity	Decreased	Normal to slight reduction



Clinical Features

The hallmark of COPD is expiratory airflow obstruction that is not fully reversible. The main symptoms are cough, sputum production, and exertional dyspnoea. Nocturnal symptoms are unusual in COPD unless associated with cardiac failure. Physical examination reveals prolonged expiration, use of accessory muscles of respiration, chest hyper-resonance on percussion, enlarged thoracic volume and decreased breath sounds. Clubbing is not a feature of COPD. Signs of cor pulmonale may be present. Marked tachypnoea, cyanosis, paradoxical abdominal motion may signify the need for assisted ventilation.

Chest radiographs are not sensitive for the diagnosis of COPD. Spirometry is the only reliable means for diagnosis and classification of COPD.

COPD exacerbation is caused by *H. influenza*, *S. pneumonia*, and *M. catarrhalis*.

Systemic Features of COPD

Systemic features	Possible mechanism
Cachexia	TNF- α , IL-6, leptin
Muscle wasting	Apoptosis of skeletal muscle due to TNF- α
Polycythaemia	Chronic hypoxia
Anaemia	TNF- α
Depression	TNF- α , IL-6
Cardiovascular abnormalities	CRP, fibrinogen
Osteoporosis	? effect of corticosteroid therapy



Development of systemic features indicate poor prognosis with survival < 1 year.

Reid Index

The ratio of the thickness of the submucosal glands to that of the bronchial wall is expressed as Reid index.

In normal individuals, it is 0.44 ± 0.09

In chronic bronchitis, it is 0.52 ± 0.08

If the submucosal layer thickness is > 50% of bronchial wall thickness it is highly suggestive of chronic bronchitis.

High index is commonly associated with symptoms.



Complications

Pneumothorax, respiratory failure and cor pulmonale.



Investigations

Chest X-ray

Shows hypertranslucency, low flat diaphragm or bullae. Translucency extends anteriorly up to the 7th rib and posteriorly up to 9th rib. Widened intercostal spaces and tubular heart are seen.

Gold Classification of COPD

FEV₁/FVC < 70% is diagnostic of COPD except stage 0 at risk

Stages: All stages may or may not have chronic symptoms.

- 0: At risk—Normal spirometry—Chronic symptoms like cough and sputum production
- I: Mild COPD—FEV₁—≥ 80% predicted
- II: Moderate COPD—FEV₁—50 to 80% predicted
- III: Severe COPD—FEV₁—30 to 50% predicted
- IV: Very severe—FEV₁—< 30% predicted or < 50% predicted with chronic respiratory failure or clinical signs of right heart failure



Management

Stage 0 at risk—Avoidance of risk factors and influenza vaccination

Assess willingness to quit smoking—advise, assist and arrange to follow-up.

- Mild COPD—Add short acting β_2 agonists Fenoterol/ Salbutamol/Terbutaline
- Moderate COPD—Add one or more long acting bronchodilators – Formoterol/Salmeterol and if needed add either short acting (Ipratropium bromide/Oxitropium bromide) or long acting (Tiotropium) anticholinergics.

- Severe COPD—Add inhaled glucocorticosteroids (Beclomethosone / Budesonide / Fluticasone / Triamcinolone and if the response is not satisfactory, add systemic glucocorticosteroids (Prednisone/ Methyl-prednisolone)
- Very severe COPD—Long-term O₂, Ventilatory assistance, management of cardiac failure, consider surgical management.

All the drugs can be administered in the form of metered dose inhaler or dry powder inhaler or MDI with a spacer device or reservoir or delivery of the drug by a nebuliser.

Methylxanthines (Aminophylline, or theophylline SR) can be added when necessary.

Oxygen should be administered to maintain a PaO₂ > 60 mm Hg or SaO₂ > 90%. Patients with chronic respiratory failure need oxygen > 16 hours/day, 2-3 L/minute and it has been shown to increase survival.

Antibiotics are needed only when there is respiratory infection.

In acute exacerbation, only parenteral steroid is useful and inhaled steroids are not useful.

Intravenous α_1 -antitrypsin (A1AT) augmentation therapy may benefit select patients with A1AT deficiency (< 50 mg/dl) and COPD.

Vaccinations—Influenza and pneumococcal vaccinations reduce serious illness and mortality in patients with COPD.

Psychoactive drugs—Patients with COPD often suffer from depression and anxiety. Low dose benzodiazepines (alprazolam 0.25–0.5 mg PO tid) produce significant anxiety reduction.

Long-term Oxygen Therapy: Indications

- COPD-Hypoxaemia-Oedema
- FEV₁ < 1.5 L, FVC < 2 L
- PaO₂ < 55 mm of Hg (7.3 kPa); PaCO₂ > 45 mm Hg (6 kPa)

Indications for Non-invasive Positive Pressure Ventilation (NIPPV)

(This mode is advocated only in patients with normal mental status, stable cardiovascular function, fairly cooperative and without respiratory arrest.)

- Severe dyspnoea with the use of accessory muscles and paradoxical abdominal motion
- Acidosis pH < 7.35 and hypercapnia PaCO₂ > 45 mm Hg (> 6.0 kPa)
- Respiratory rate > 25/minute.

Indications for Invasive Mechanical Ventilation

- Dyspnoea with the use of accessory muscles and paradoxical abdominal motion



- Respiratory rate > 35/minute
- Hypoxia – $\text{PaO}_2 < 5.3 \text{ kPa}$ (40 mm Hg) or $\text{PaO}_2/\text{FiO}_2 < 200 \text{ mm Hg}$
- Severe acidosis – $\text{pH} < 7.25$ and hypercapnia $\text{PaCO}_2 > 60 \text{ mm Hg}$ (> 8 kPa)
- Respiratory arrest
- Altered sensorium
- Unstable cardiovascular function—hypotension, shock, failure
- Sepsis, pulmonary embolism, massive pleural effusion, barotraumas
- NIPPV failure.

Surgical Management

- Bullectomy
- Lung volume reduction surgery—resection of damaged portion of lung
Improves exercise tolerance but does not improve life expectancy
- Lung transplantation $\text{FEV}_1 < 35\%$ ($\text{PaO}_2 < 60 \text{ mm Hg}$ and $\text{PaCO}_2 > 50 \text{ mm Hg}$).

Bronchiectasis

Persistent and irreversible dilatation and distortion of medium sized bronchi (5th to 9th generation) by more than 2 mm.

Bronchiectasis may be due to bronchial distention occurring as a result of chronic obstruction and recurrent infection.

Factors Predisposing to Bronchiectasis

Congenital

- Primary
- Secondary
 - Tracheobronchomegaly (Mounier-Kuhn syndrome)
 - Bronchomalacia (William-Campbell syndrome)
 - Pulmonary sequestration (intrapleural, extrapleural)
 - Kartagener's syndrome (bronchiectasis, sinusitis, situs inversus)
 - Young's syndrome (idiopathic obstructive azoospermia)
 - Yellow nail syndrome (lymphoedema, yellow nails and pleural effusion)
 - Cystic fibrosis
 - α_1 anti-trypsin deficiency
 - Immunodeficiency syndromes (hypogammaglobulinaemia).
 - Chandra-Khetarpal syndrome—Levocardia, sinusitis and bronchiectasis, but no ciliary abnormality.

Acquired

- Infections*: Measles, whooping cough, bronchitis, bronchiolitis, pneumonia, endobronchial tuberculosis.
Adenovirus, influenza and HIV infections can also predispose to bronchiectasis.
- Bronchial obstruction*: Foreign body, tumour (adenoma/carcinoma), lymph nodes, left atrium, aneurysm [causes may be inside the lumen, on the wall or outside the wall].
- Associated immune disorders*: Ulcerative colitis, SLE, rheumatoid disease, ABPA.

Pathogenesis

The bronchial dilatation in bronchiectasis is associated with destructive and inflammatory changes in the walls of medium sized airways, often at the level of segmental or sub-segmental bronchi. Inflammation is primarily mediated by neutrophils and it leads to upregulation of enzymes, such as elastase and matrix metalloproteinases. The normal structural component of the wall, including cartilage, muscle and elastic tissue are destroyed and replaced by fibrous tissue. The dilated airway frequently contain pools of thick purulent material while more peripheral airways are often occluded by secretion or obliterated and replaced by fibrous tissue.

Types

1. Cylindrical bronchiectasis
2. Saccular (cystic) bronchiectasis
3. Varicose bronchiectasis.



Clinical Features

Persistent, recurrent cough and large quantity of purulent sputum production; haemoptysis; persistent coarse leathery crackles, with or without bronchial breathing (associated consolidation). Any combination of crackles, rhonchi and wheezes can occur. Clubbing of fingers and toes are present.

Bronchiectasis is common in left lower lobe because the lower lobe bronchus is longer and narrower. Middle lobe and lingual are next frequently involved. Involvement of upper lobe is uncommon.

Sequestration of Lung

It is a region of lung parenchyma that has an incomplete or no connection with the airways and is supplied by an aberrant artery arising from aorta or one of its



branches. When it shares common visceral pleural investment with the adjacent normal lung tissue, it is called intralobar sequestration. When it has its own pleural lining, it is called extralobar sequestration.

Upper Lobe Bronchiectasis

This involves posterior and apical segments of upper lobe. It is common in tuberculosis, cystic fibrosis and ABPA.

Dry Bronchiectasis (Bronchiectasis Sicca)

Only haemoptysis is present; there is no sputum production; usually seen in upper lobe involvement in tuberculosis.

Middle Lobe Bronchiectasis (Brock's Syndrome)

This is a term applied to recurrent atelectasis of the right middle lobe (RML) in the absence of endobronchial obstruction. After several episodes of atelectasis, bronchiectasis and chronic fibrosis of the RML may develop. It is usually sequelae to primary pulmonary tuberculosis resulting from obstruction of middle lobe bronchus by TB lymph nodes.

Right middle lobe is involved because:

1. RML bronchus originates as a narrow and often slit-like lumen.
2. RML bronchus is surrounded by a network of lymph nodes draining both middle and lower lobes, which with infection enlarge and compress the bronchus.
3. RML bronchus before bifurcating into medial and lateral segments, runs a longer course (0.75 cm).
4. RML is separated by fissures and by a pleural envelope from the upper and lower lobes and lacks collateral ventilation.

Pseudo (Reversible) Bronchiectasis

It is a temporary bronchial dilatation occurring in an area of lung affected by pneumonic consolidation, tracheobronchitis or lung collapse.



Complications

1. Haemoptysis—may be life threatening.
2. Metastatic abscess (brain, pericardium, etc.)
3. Pneumothorax.
4. Cor pulmonale and right ventricular failure.
5. Amyloidosis
6. Recurrent pneumonia at the same site
7. Pyothorax
8. Lung abscess.



Investigations

Assessment of Ciliary Function

A pellet of saccharine is placed on anterior chamber of nose. The time taken for it to reach the pharynx, so that the patient can taste it, is noted. Normally it should not exceed 20 minutes. It is greatly prolonged in patients with ciliary dysfunction.

Sputum Examination

This is done for identifying the infecting organisms. Classically, a 3 layered sputum is seen (upper layer—frothy and watery, middle layer—turbid and mucopurulent, lower layer—purulent and opaque).

Chest X-ray (Fig. 4.31)

Shows ring shadows, tram track sign, gloved finger appearance, evidence of fibrosis or cor pulmonale.

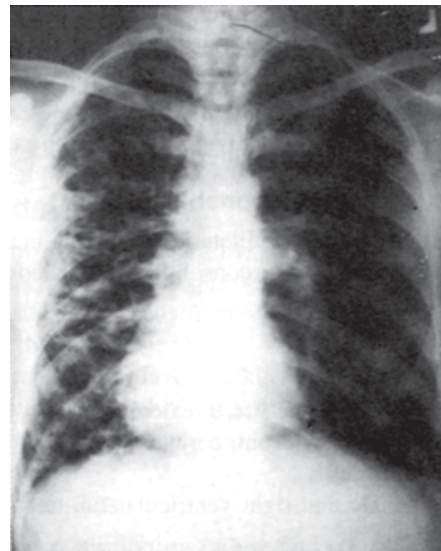

Fig. 4.31: Right sided bronchiectasis

CT Scan (Fig. 4.32)

It is a non-invasive diagnostic test.

Thick sections—more specific

Thin sections—more sensitive.

Bronchiectasis of proximal airways is suggestive of ABPA. Whereas nodular bronchiectasis suggests *Mycobacterium avium* complex infection.

Bronchography (Fig. 4.33)

It provides excellent visualisation of bronchiectatic airways, which helps in confirming diagnosis and for planning surgery.

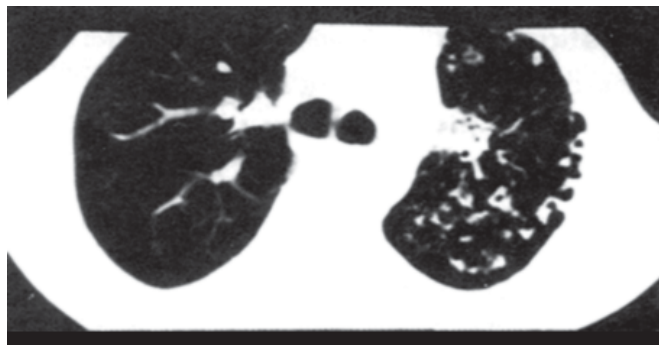

Fig. 4.32: CT scan—bronchiectasis right lung

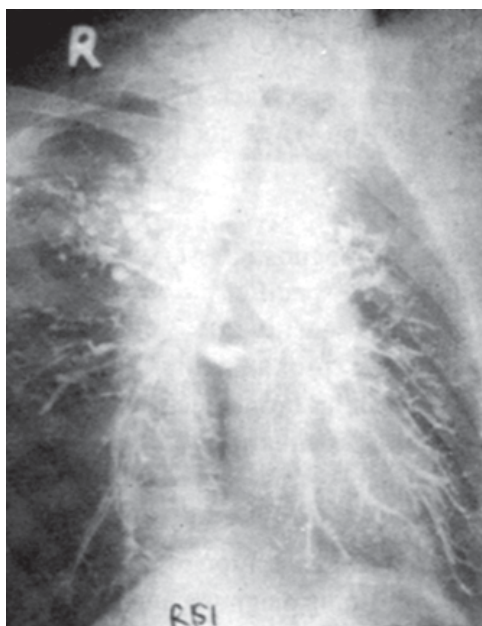

Fig. 4.33: Bronchogram—bronchiectatic changes

FOB: It is very useful in focal bronchiectasis to reveal endobronchial obstruction

PFT: Pulmonary function tests can also be performed.



Management

1. Control of infections by using appropriate antibiotics.
2. Improved clearance of tracheobronchial secretions by adequate hydration, chest physiotherapy with percussion, vibration and postural drainage.

Mucolytics are also tried (adequate hydration, acetyl cysteine, bromhexine). Percussion therapy should not be attempted when the patient has haemoptysis.

3. Reversal of air flow obstruction by bronchodilators.
4. Elimination of underlying problem (immunoglobulin replacement, ATT, steroids for ABPA).
5. Treatment of complications:
 - a. Massive haemoptysis—when this is not controlled with conservative measures (bed rest, antibiotics, blood transfusion), other options like surgical resection (when disease is localised) or bronchial artery embolisation (when disease is widespread) may be resorted to.
 - b. Treatment of chronic hypoxaemia and cor pulmonale with long-term supplemental oxygen.
 - c. Aerosolised recombinant DNase which decreases viscosity of sputum by breaking down DNA released from neutrophils has been shown to improve pulmonary function.
6. *Surgery:* Surgery is done only for localised disease when the remaining lung and/or the other lung is normal and when there is no systemic causal factor. Surgery is contraindicated in extremes of age and in bilateral extensive lesions.
7. Lung transplantation should be considered if the disease is widespread.

Cystic Fibrosis

Cystic fibrosis (CF) is the most common, autosomal recessive disorder, with the basic defect in the gene located on the long arm of chromosome 7, which results in the deficiency of cystic fibrosis transmembrane conductance regulatory protein (CFTCR). CFTCR is a chloride channel activator, activated by a combination of phosphorylation of protein kinase A and binding of ATP.

This genetic defect results in a reduction in the movement of ions in and out of cell and a reduction in the amount of water in the secretions. In lungs, CF airway epithelia exhibit both increased transport rates for Na^+ and decreased ion permeability for Cl^- ; there is raised transepithelial electric potential difference. CF epithelia do not respond to β agonists or agonists of protein kinase c, with chloride secretion as normal airway epithelia do. There is hyperabsorption of Na^+ .

CF is a multi-system disease involving lung, pancreas, sweat glands, and urogenital tract.



Clinical Features

Respiratory/Cardiovascular

- a. Bronchitis, bronchopneumonia, bronchiectasis, lung abscess, ABPA



- b. Atelectasis
- c. Sinusitis, nasal polyposis
- d. Pulmonary hypertension
- e. Cor pulmonale and congestive heart failure
- f. Haemoptysis
- g. Pneumothorax
- h. Respiratory failure.

Gastrointestinal

Intestinal

- a. Meconium ileus
- b. Volvulus
- c. Ileal atresia
- d. Rectal prolapse
- e. Intussusception
- f. Faecal impaction
- g. Pneumatosis intestinalis.

Pancreatic

- a. Nutritional deficit and growth failure due to pancreatic insufficiency
- b. Steatorrhoea
- c. Diabetes mellitus
- d. Recurrent pancreatitis.

Hepatobiliary

- a. Atrophic gallbladder, cholelithiasis
- b. Loss of bile salts
- c. Focal biliary cirrhosis
- d. Portal hypertension
 - i. Oesophageal varices
 - ii. Hypersplenism
 - iii. Haemorrhoids

Reproductive System

- a. *Males: Sterility:* Absent or defective vas deferens, epididymis and seminal vesicles (in about 99% of males).
- b. *Females: Decreased fertility:* Increased viscosity of vaginal secretions.

Skeletal

- a. Retardation of bone age
- b. Demineralisation
- c. Hypertrophic osteoarthropathy.

Others

- a. Salt depletion
- b. Heat stroke
- c. Salivary gland hypertrophy
- d. Retinal haemorrhage
- e. Hypertrophy of apocrine glands.



Complications

1. Recurrent respiratory infections (*Pseudomonas*, staphylococci, *Burkholderia* and *H. influenzae*).
2. Pneumothorax
3. Massive haemoptysis
4. Respiratory failure
5. Cor pulmonale
6. ABPA (in 20%).



Differential Diagnosis

1. Primary ciliary dyskinesia may lead to bronchiectasis, sinusitis, and infertility. Sweat chloride value is normal.
2. Shwachman syndrome – Pancreatic insufficiency, cyclic neutropenia and lung disease may simulate CF, but sweat chloride value is normal.
3. Young syndrome (bronchiectasis, sinusitis and azoospermia) in men lacks GI symptoms and has normal sweat chloride levels.



Investigations

Chest X-ray

Hyperinflation, leading to changes of bronchiectasis later. Evidence of mucus impaction, destructive emphysematous changes with cystic change, fibrosis may also be seen.

Sweat Test

Pilocarpine iontophoresis stimulates sweat secretion. If sweat chloride > 70 mEq/L, on two different occasions, diagnosis of CF is confirmed. Normal value of sweat chloride is less than 50 mEq/L.

Other conditions with increased sweat chloride value:

- Addison disease
- Untreated hypothyroidism.

Pulmonary Function Tests

Shows evidence for small and large airway obstruction.



Management

1. Appropriate antibiotics (tobramycin or gentamicin aerosol) for *Pseudomonas* infection for 2–3 weeks. Oral ciprofloxacin 500 mg BD or ofloxacin 200–400 mg BD can be given for minor infections. For major



infection, oral and single or double IV drugs can be used.

Antipseudomonal antibiotics:

- Ceftazidime 2 g IV q8hrly
- Cefepime 2 g IV q12hrly
- Tobramycin 3 mg/kg/day
- Gentamicin 5 mg/kg single* dose

A combination of semi-synthetic penicillin or cephalosporin with anti-pseudomonal activity and an aminoglycoside has to be given.

* Aminoglycoside has to be given in single dose except in:

- Pregnant patients
- Infective endocarditis
- Burns involving more than 20% of body
- Cystic fibrosis
- Anasarca
- Creatinine clearance < 20 ml/mt

- Human recombinant DNase—decreases sputum viscosity and increases airflow.

Alfa dornase acts by digesting extracellular DNA from dead neutrophils, and it has shown to improve pulmonary function and to decrease risk of respiratory tract infections.

The recommended dose of dornase α is 2.5 mg (one ampule)/day inhalation by using a jet nebuliser.

- Uridine Triphosphate (UTP)—a chloride channel activator.
- Amiloride inhaler*: It is a sodium channel blocker which inhibits sodium reabsorption into the respiratory epithelial cells and thereby reduces sputum viscosity and improves lung function.
Dose: 3 ml of 10^{-3} mol solution as inhalation.

- Mucolytics*: Adequate hydration + acetylcysteine, carbocysteine can be tried.

Ambroxol hydrochloride 30-60 mg TDS and bromhexine can be tried.

Other uses of acetyl cysteine:

1. Antidote to paracetamol poisoning, ratol poisoning and carbon tetrachloride poisoning
2. Combined use of nitroglycerine and N-acetyl cysteine in the management of unstable angina.
3. In colposcopy to clean the cervix and to remove cervical mucus prior to colposcopy.
4. To prevent radiographic contrast induced reduction in renal function.
5. In cystitis caused by cyclophosphamide, it is used to irrigate the bladder.

Hypertonic saline inhalation – 4 mL of 7% saline bid. Inhalation of bronchodilator is essential to avoid saline induced bronchospasm.

6. Clearing pulmonary secretions by chest percussion and breathing exercises. High frequency percussion jackets are also used.
7. β_2 -agonists (may facilitate Cl^- secretion).
8. α_1 -antitrypsin inhalation helps in restoring anti-pseudomonas properties.
9. Treatment of complications (oral steroids for ABPA, oxygen therapy in cor pulmonale, treatment of pneumothorax by surgery, chemical pleurodesis, thoracoscopy with CO_2 laser ablation).
10. *Gene therapy*: 'CF' gene could be packaged within a liposome or incorporated by genetic engineering into a modified viral vector and delivered to the respiratory epithelium with the aim of correcting the defect.
11. Either sequential single lung transplant or heart lung transplant can be done.

Tuberculosis

It is a pulmonary and systemic disease caused by *Mycobacterium tuberculosis*.

Transmission is by droplet nuclei of 1-5 μ in diameter which deposit on the alveoli.

There is increased incidence of tuberculosis in HIV positive patients.

Natural History of Tuberculosis

Most primary tuberculous infections heal spontaneously.

<i>TB affecting various organs</i>	<i>Time taken after primary infection</i>
Miliary TB or TB meningitis	Within 6 months
Pleural effusion	Within 6-12 months
Progressive primary tuberculosis with cavity	Within 1-2 years or even later
Skeletal tuberculosis	1-5 years after primary infection
Genito-urinary and skin tuberculosis	5-15 years after primary infection

Primary Tuberculosis

The initial infection usually occurs in the lung or may be in the tonsil or GI tract.

Ghon's focus is a subpleural focus usually at the lower border of upper lobe or upper border of lower lobe. The combination of primary or Ghon's focus and the draining lymph nodes is known as *Ghon's complex* or *Primary complex*. The initial infection resolves spontaneously in most individuals. Remnants of the healed lesions appear on chest X-ray as calcified parenchymal



nodules (*Ghon's lesions*) often associated with calcified hilar nodes (*Ranke's complex*).

In a small percentage of patients, the initial infection progresses and manifests as

1. Rupture into pleural space causing tuberculous pleurisy
2. Extensive caseous pneumonia
3. Enlargement of tuberculous lymph nodes resulting in bronchial obstruction (collapse consolidation lesions—Epileptuberculosis)
4. Rupture of TB focus into a bronchus leading to endobronchial tuberculosis
5. Rupture into a pulmonary blood vessel causes haematogenous spread, resulting in acute dissemination.

The factors causing 'breakdown' of previously healed lesions are:

1. Malnutrition
2. Alcoholism
3. Poorly controlled diabetes mellitus
4. Silicosis
5. Immunosuppression (by disease or drugs)
6. Post-partum period
7. Post-gastrectomy and jejunioileal bypass surgery
8. Chronic haemodialysis.



Clinical Features

Fever, fretfulness, loss of appetite, cough, wheeze; sputum production is rare in children. Usually there are no detectable clinical signs except occasional crackles and wheezes.

Erythema nodosum (bluish red, raised, tender lesions over shin and thigh), phlyctenular conjunctivitis (1–3 mm shiny yellow or grey bleb at limbus) may be associated with primary infection. These are manifestations of hypersensitivity reactions (Fig. 4.34).

Miliary Tuberculosis

This is produced by acute dissemination of TB bacilli via bloodstream resulting in the appearance of discrete nodular shadows about the size of a millet seed (2 mm).



Clinical Features

High pyrexia with drenching night sweats, tachycardia, loss of weight, anaemia; usually no physical signs in the chest; a few crackles may be heard; hepatosplenomegaly often present; choroid tubercles on fundus examination. Death takes place in untreated patients.

Hepatosplenomegaly, lymphadenopathy and meningism may also be present.



Fig. 4.34: Bilateral pulmonary tuberculosis

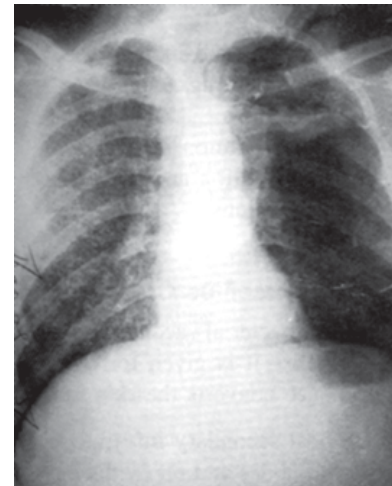

Fig. 4.35: Miliary mottling both lung fields

Sputum for AFB is negative in more than 80% of cases.

Cryptic Miliary Tuberculosis

It is seen in elderly and also in females. There are no choroid tubercles and tuberculin test may be negative. It is usually an autopsy diagnosis. It is associated with neutropenia, pancytopenia, leukemoid reaction. Patient may have hepatosplenomegaly. Chest X-ray is usually normal (size of tubercles < 0.5 mm).



Investigations

1. *Chest X-ray*: Symmetrical miliary mottling (it takes 3–6 weeks for radiological appearance)
2. Culture of sputum, urine, bone marrow (Fig. 4.35).



3. Liver biopsy in difficult cases
4. *Mantoux test*: May be negative
5. Transbronchial and bone marrow biopsy are useful.

Post-primary Pulmonary Tuberculosis

The lesions are usually situated in the posterior segment of upper lobes or apical segment of lower lobe because of high ventilation perfusion ratios with elevated alveolar PO₂ relative to other zones.

Simon Focus

It is present in the apical or posterior segment of upper lobe. Seedling of bacilli in this area is favoured by high PO₂ of the region.

Caseous material contains 1×10^4 bacilli per gram whereas 1×10^9 (100 crores) organisms are harboured in a cavitory lesion. Tenacious sputum is more infectious than thin sputum.



Clinical Features

Insidious onset of cough and sputum; initially there are no physical signs; later, crackles over lung apex, signs of consolidation, cavity or fibrosis develop. Pleural effusion (hypersensitivity reaction) or spontaneous pneumothorax are other types of presentation.

Haemoptysis is due to the rupture of a hypertrophied bronchial vessel (Rasmussen's aneurysm).

Haemoptysis is also due to erosion of blood vessel in the wall of the cavity or aspergilloma formation in an old cavity.



Complications

1. Pleurisy
2. Pneumothorax
3. Empyema, pyopneumothorax
4. TB laryngitis
5. TB enteritis
6. COAD like picture
7. Respiratory failure, RV failure
8. Blood-borne dissemination
9. Aspergilloma
10. Poncet's disease (polyarthritis)
11. TB of spine (Pott's disease)
12. Scar carcinoma.

Non-reactive Miliary TB

- Acute septicaemic form
- Due to massive haematogenous dissemination of *tubercle bacilli*

- Pancytopenia is more common
- Incidence – very rare and is rapidly fatal
- Postmortem – Multiple necrotic non-granulomatous lesion

Endobronchial and Laryngeal Tuberculosis

It is usually associated with extensive cavitory disease. Laryngeal TB is extremely infectious. Chest X-ray is normal; Sputum AFB is positive.

TB Meningitis

TB meningitis presents with headache, lethargy, confusion. CSF shows lymphocytic pleocytosis, glucose < 20 mg/dl and a markedly elevated protein. CSF smear is positive in 20% and culture in 75%. Pathologically, there is cranial arteritis causing cranial nerve palsies, hydrocephalus, etc.

TB meningitis usually results from acute haematogenous spread or rupture of subependymal nodule into the subarachnoid space.

Genito-urinary Tuberculosis

It presents as painless haematuria and sterile pyuria. Renal parenchyma, calyces, ureters and bladder are affected in descending order. Early morning urine cultures, IVP and sometimes cystoscopy are indicated. Testicular and epididymal involvement may be present, which may lead to sterility. In females, involvement of fallopian tubes leads to infertility.

Bone and Joint Tuberculosis

It presents with pain, joint swelling and parosseous 'cold' abscesses and sinus tract formation. Weight bearing joints are involved, especially spines (Pott's disease), hips and knees. Early diagnosis by joint aspiration and biopsy is needed to prevent disability and to avoid surgery.



Investigations

Chest X-ray

Often shows lesions before serious symptoms develop. Earlier, showing ill defined opacities over apex, unilaterally and later, showing bilateral involvement, evidence of fibrosis, cavity, consolidation, pneumothorax or pleural effusion.

Laboratory Diagnosis of Tuberculosis

1. Sputum examination (at least thrice by concentration method) for AFB by Ziehl-Neelsen technique



when bacilli are numerous or Auramine-phenol fluorescent test when bacilli are small in number. For sputum positivity, there should be a concentration of > 50,000 bacilli/ml of sputum.

2. In smear negative cases, culture of sputum or bronchoalveolar lavage fluid or fasting gastric washings or laryngeal swabs should be done.
3. Culture and drug sensitivity tests using 'BACTEC' radiometric method. In this method, ^{14}C labelled palmitic acid is incorporated into a liquid culture medium. Growth of mycobacteria is detected by the liberation of $^{14}\text{CO}_2$, produced as a result of metabolism of palmitic acid by the viable mycobacteria, which in turn can be measured.
4. DNA probe technology can provide a rapid (within hours) method of detecting the presence of mycobacteria in cultured material and in clinical specimens as well.
5. Polymerase Chain Reaction (PCR) technique is a sensitive and specific assay performed on clinical specimens.
6. ELISA testing for IgG antibodies has a specificity of 97% and a sensitivity of 65%.

It only denotes past infection, but not useful as diagnostic aid.

Tuberculin Test

1 to 5 U of PPD is injected intradermally using a 27 G needle on the flexor aspect of the fore arm. The extent of induration is measured 48–72 hours later.

Interpretation

0–4 mm	Negative
5–9 mm	Doubtful (may be due to atypical mycobacteria)
10 mm or more	Positive

In HIV infected individuals, 5 mm is considered positive.

Tuberculin negative patients should be vaccinated with BCG.

False-negative tuberculin tests (*i.e. negative skin tests occurring in patients with tuberculosis*).



Causes

1. Infections (measles, mumps, chickenpox, typhoid, leprosy)
2. AIDS
3. Hodgkin's disease, lymphoma, leukaemia, sarcoi-dosis
4. Protein malnutrition
5. Miliary tuberculosis, TB meningitis
6. Immunosuppressive drugs
7. Newborn and elderly
8. Faulty storage or dilution of PPD
9. Errors of administration and recording
10. Live viral vaccinations.

BCG Vaccination (Bacillus Calmette-Guérin)

It is a live, attenuated bacterial vaccine given at lower deltoid (0.1 ml) intradermally. It is given for tuberculin negative individuals and hence converts the skin test positive.

Complications: Local secondary infection, cold abscess or swelling of regional nodes and rarely disseminated BCG in immunosuppressed individuals. Not to be given in patients with extensive dermatosis.



Management of Tuberculosis

First line drugs

1. Rifampicin
2. INH
3. Pyrazinamide
4. Ethambutol

Second line drugs

1. Injection Aminoglycosides (streptomycin/kanamycin/amikacin)
2. Capreomycin
3. PAS
4. Ethionamide
5. Kanamycin
6. 3rd generation fluoroquinolones (gatifloxacin/moxifloxacin/levofloxacin)
7. Viomycin
8. Cycloserine

Some important WHO definitions must be understood for the proper therapy.

1. *New case:* A patient who has never had treatment for TB or who has taken antituberculosis drugs for less than one month.
2. *Relapse:* A patient previously treated for TB who has been declared cured or treatment completed, and is diagnosed with bacteriologically positive (smear or culture) tuberculosis.
3. *Treatment after failure:* A patient who is started a re-treatment regimen after having failed previous treatment.
4. *Treatment after default:* A patient who returns to treatment, positive bacteriologically, following interruption of treatment for two months or more.



5. *Chronic case*: A patient with TB who is sputum positive at the end of a standard re-treatment regimen with essential antituberculosis drugs.
6. *MDR – TB*: A patient who has active tuberculosis with bacilli resistant at-least to both rifampicin and isoniazid.

Essential Anti-tuberculosis Drugs (mg/Kg body weight)

Essential drugs	Daily	Three times weekly
Isoniazid (H)	5	10
Rifampicin (R)	10	10
Streptomycin (S)	15	15
Ethambutol (E)	15	30
Pyrazinamide (Z)	25	35
Thioacetazone (T)	2.5	Not applicable

Treatment Regimens in Special Situations

Pregnancy

Most antituberculosis drugs are safe for use in pregnancy. Do not use streptomycin which is ototoxic and nephrotoxic to the foetus.

Pregnancy – 2HRE + 7HR

Breast-feeding

All antituberculosis drugs are compatible with breast feeding. The baby should be given prophylactic isoniazid for at least three months (till the mother is declared non-infectious). BCG vaccination of the newborn should be postponed until the end of isoniazid prophylaxis. Vitamin K should be given at birth to the infant of a mother taking rifampicin.

Reserve Antituberculosis Drugs

Thrice weekly regimens are not recommended for reserve antituberculosis drugs.

Reserve drugs	Mode of action	Average (mg/kg)/day	Minimum (mg)	Maximum (mg)
Amikacin (Am)	Bactericidal	15	750	1000
Capreomycin (Cm)	Bactericidal	15	750	1000
Kanamycin (Km)	Bactericidal	15	750	1000
Ciprofloxacin (Cx)	Bactericidal	10–20	1000	1500
Ofloxacin (O)	Bactericidal	10–15	600	800
Cycloserine (Cs)	Bacteriostatic	10–20	500	750
Ethionamide (Et)	Bactericidal	10–20	500	750
PAS	Bacteriostatic	150	8 g	12 g
Protionamide (Pt)	Bactericidal	10–20	500	750

WHO Recommended Treatment Regimens

Diagnostic category	TB patients	Initial phase (daily or three times weekly)	Continuation phase (daily or three times weekly)
I	a. New smear positive patients b. New smear-negative PTB with extensive parenchymal involvement c. Concomitant HIV disease d. Severe extra-pulmonary TB	2 HRZE*	4 HR
II	Previously treated smear positive PTB: <ul style="list-style-type: none"> • Relapse • Treatment after interruption • Treatment failure 	2 HRZES +1 HRZE	5 HRE
III	New smear negative PTB (Minimal) Less severe forms of EPTB	2 HRZ	4 HR

*Streptomycin may be used instead of ethambutol especially in meningeal TB



Oral Contraception

Rifampicin reduces the effectiveness of oral contraceptives by inducing hepatic enzymes.

The individual should adopt another form of contraception or an oral contraceptive pill containing a higher dose of estrogen (50 µg) may be taken.

HIV Infection

Thioacetazone is contraindicated in those who are HIV infected.

Liver Disorders

Isoniazid, rifampicin and pyrazinamide are all associated with hepatitis. Out of these three drugs rifampicin is least toxic and pyrazinamide is the most hepatotoxic.

Acute hepatitis: If possible, avoid TB treatment until the acute hepatitis has resolved. If not possible, treat with

3 SE + 6 HR (if hepatitis has resolved in three months). If the hepatitis has not resolved, SE should be continued for a total of 12 months.

Established chronic liver disease: Do not use pyrazinamide. Recommended regimens are the following: 2 SHRE followed by 6 HR; or 9 RE; or 2 SHE followed by 10 HE.

Renal Failure

Streptomycin and ethambutol are excreted by the kidneys. Thioacetazone is partly excreted by the kidneys. Avoid these drugs in renal failure. The safest regimen for patients with renal failure is 2 HRZ followed by 4 HR

Mode of Action in Interruption of TB Treatment

Interruption less than 1 month—Prolong the duration to compensate the missed doses.

Sample Regimen: Accurate Dosage of Antituberculosis Drugs with Fixed Dose Combinations According to Weight Bands

	Weight in kg			
	30-39	40-54	55-70	> 70
Initial phase—Daily				
HRZE (75 mg + 150 mg + 400 mg + 275 mg)	2	3	4	5
HRZS (HRZ- 75 mg + 150 mg + 400 mg)	2	3	4	5
S-Streptomycin 1g vial – for 2 months	0.5	0.75	1	1
Continuation phase—Daily				
HR – (75 mg + 150 mg)	2	3	4	5
Category II add E 400 mg	1.5	2	3	3
Continuation phase—Thrice weekly				
HR–(150 mg + 150 mg)	2	3	4	5
Category II add E – 400 mg	2	4	6	6

Management of chronic and multi-drug resistant cases

Susceptibility testing to essential drugs	Initial phase		Continuation phase	
	Drugs	Duration	Drugs	Duration
Not available	HRZES	3 months	HRE	5 months
Resistance to H + R	ZEQ + anyone aminoglycoside			12-18 months
Resistance to all essential drugs	One aminoglycoside + Any 3 out of the four drugs given below (Ethionamide, Cycloserin, PAS, Quinolone)			24 months



Interruption for 1-2 months—Do sputum for AFB 3 times – smear negative – prolong therapy to compensate for missed doses. If smear positive – treatment received < 5 months – prolong therapy to compensate for missed doses; treatment received > 5 months—If on category I regimen – start category II; If already on category II regimen—refer to specialised centre to rule out resistance and to decide the type of regimen.

Name of the drug	Dosage	Side effects
Rifampicin	10–20 mg/kg; 450 mg if < 50 kg; 600 mg if > 50 kg	Hepatitis, orange urine, flu-like syndrome, cutaneous syndrome, inactivates oral contraceptives, thrombocytopenia
INH	10 mg/kg; In adults 300 mg	Hepatitis, B ₆ deficiency, neuropathy, agranulocytosis, rarely INH cysts
Ethambutol	25 mg/kg × first 8 weeks 15 mg/kg later.	Optic neuritis
Pyrazinamide	20–35 mg/kg; in adults, < 50 kg—1.5 g > 50 kg—2 g	Arthralgia, hepatitis, hyperuricaemia

Drugs acting in acid medium: Pyrazinamide—acts on intracellular organisms.

Drugs acting in alkaline medium: Streptomycin—acts on extracellular organisms.

Drugs acting on intracellular, extracellular organisms in both acid and alkaline medium are: INH, Rifampicin—acts on persistors also.

Drugs crossing blood brain barrier: INH, Rifampicin and Pyrazinamide; Streptomycin crosses the blood-brain barrier poorly.

It takes 3 weeks for sputum conversion if regimens containing rifampicin are used and 3 months for regimens without rifampicin.

Other Antituberculous drugs

- Rifabutine
- Sparfloxacin
- Clarithromycin
- Azithromycin
- Clofazimine

Principles of Chemotherapy

- Always multi-drug regimen should be used
- In almost all short regimens INH and rifampicin are included
- Rifampicin is the most potent sterilising drug
- Ethambutol and thioacetazone are added along with powerful drugs to prevent emergence of resistant bacilli
- DOT—Directly observed treatment means that an observer watches the patient swallowing their tablets. DOT ensures accountability of TB services and helps to prevent emergence of drug resistance. DOT is recommended in the initial phase of treatment, at least for all smear positive cases and the continuation phase of rifampicin containing regimens.
- INH alone is used to prevent
 - i. Development of active TB in immunodeficient individuals
 - ii. Progression of infection to primary complex in those recently infected
 - iii. Transmission to close contacts at high risk
- Contact lenses may be irreversibly stained during rifampicin therapy

Reserve Antituberculosis Drugs—Side Effects

Name of the drugs	Side effects
Kanamycin and Amikacin	Ototoxicity, deafness, vertigo, nephrotoxic
Capreomycin	Tinnitus, vertigo, lesser risk of deafness, renal damage, cutaneous reactions, hypokalaemia, hypocalcaemia, hypomagnesaemia, hepatitis
Ethionamide (or protionamide)	Metallic taste, anorexia, nausea, epigastric discomfort, vomiting, excessive salivation, hypoglycaemia, hallucinations, depression, hepatitis, goitre-hypothyroidism, gynaecomastia, impotence, acne, headache, menstrual disorders, peripheral neuropathy
Ofloxacin and ciprofloxacin	Anorexia, nausea, vomiting, dizziness, headache, mood changes, rarely convulsions, injury to growing cartilage and impair growth
Cycloserine	Headache, dizziness, slurred speech, confusion, depression, insomnia, tremor, convulsions, avoid in epileptics and mental illness
P-Aminosalicylic acid (PAS)	Anorexia, nausea, vomiting, abdominal discomfort, hypokalaemia, hepatic dysfunction, hypothyroidism and goitre



- Antiretroviral drugs interact with rifampicin—reduces the effect of both drugs
- Blood glucose level is labile when on pyrazinamide therapy
- Streptomycin is contraindicated in:
 - i. Known hypersensitivity
 - ii. Auditory nerve impairment
 - iii. Myasthenia gravis
- Cross-resistance between kanamycin and amikacin is usual. Among aminoglycosides streptomycin is least nephrotoxic
- Streptomycin should be avoided during pregnancy and children
- Capreomycin has no cross resistance with other aminoglycosides
- Ethionamide and PAS have anti-thyroid effect
- PAS is best avoided in renal failure as it may exacerbate acidosis.

Corticosteroid Therapy in TB

1. TB meningitis
2. In seriously ill patients, before chemotherapy becomes effective
3. TB in serous sacs (peritonitis, pericarditis and pleural effusion to prevent fibrosis and adhesions and to facilitate absorption of fluid)
4. Genito-urinary TB
5. To control drug hypersensitivity reaction
6. Rarely for regression of lymph nodes during chemotherapy.

HIV and Tuberculosis

TB has a rapidly progressive and often a fatal course in HIV positive patients. Increased re-activation of latent PT occurs. Mantoux test is false-negative. Smear may be negative and hence culture is vital. There are many atypical features. There is higher frequency of miliary tuberculosis, hilar adenopathy, extrapulmonary involvement. There is lower frequency of focal infiltrates and cavities.

Congenital TB

It is very rare. TB in the mother is invariable. Infant presents with failure to thrive, hepatosplenomegaly and lymphadenopathy, obstructive jaundice due to glands in the porta hepatis. Treatment is by using 3 drug regimen and steroids.

Pneumonia

Exudative solidification of lung tissue is known as pneumonic consolidation.

Classification

1. Community acquired pneumonia (CAP)
2. Health care associated pneumonia (HCAP)
 - a. Nosocomial (hospital acquired) pneumonia (HAP)
 - b. Ventilator associated pneumonia (VAP)

Pathological Stages in the Development of Pneumonia

1. Stage of congestion—indus crepitus (fine crackles) heard
 2. Stage of red hepatisation
 3. Stage of grey hepatisation
 4. Stage of resolution—Redux crackles appear, fine crackles become coarse.
- } Tubular type of bronchial breathing heard

Predisposing Factors

Bronchopneumonia

1. Extremes of age
2. Immunosuppression (disease or drugs).

Lobar Pneumonia

1. Disorders of swallowing, coughing and impairment of airway defence mechanisms (old age, convulsions, chronic bronchitis, bronchiectasis, neurological disorders, trauma)
2. Fluid accumulation in alveoli (CCF, ARDS, burns)
3. Impaired phagocytosis and compromised immunity (hypo-gammaglobulinaemia, AIDS, diabetes, lymphoma, myeloma, functional asplenia, sickle cell anaemia).



Clinical Features

Fever, tachypnoea, pleuritic pain, cough with sputum (rusty in pneumococcal pneumonia), haemoptysis, confusion, signs of consolidation.



Investigations

1. Sputum examination (Gram's stain and culture)
2. Blood culture
3. Serology for *Mycoplasma*, *Chlamydia*, *Legionella* and viral infections.
4. Examination of pleural fluid in parapneumonic effusions
5. Chest X-ray shows evidence of consolidation (homogenous opacity) of the affected lobe or segment (Fig. 4.36). May show evidence of pleural effusion. Second chest X-ray is a must in all cases of pneumonias after

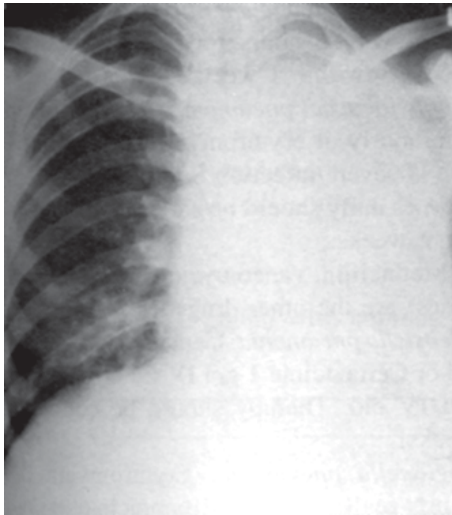

Fig. 4.36: Opaque left hemithorax without mediastinal shift massive consolidation

- 7–10 days to assess the response to therapy and to find out if there is development of any complication.
6. PCR – Legionella, Mycoplasma, Chlamydia
 7. Urine antigen test for legionella and pneumococcus.

Assessment of Prognosis

1. PSI – pneumonia severity index
20 variables like age, existing illness, physical and laboratory findings are taken into account to derive 5 classes of patients. Treat class I and II as OP, class III as IP and class IV and V at ICU.
This formula is not very useful for practical application.
2. CURB 65 (Age > 65 years)
C – Confusion
U – Urea > 7 mmol/L
R – Respiratory rate > 30/minute
B – BP – Systolic < 90, Diastolic < 60 mm of Hg
Score – 0 Out-patient
2 In- patient
3 Intensive care unit



Complications

1. Circulatory failure
2. Septicaemia
3. Parapneumonic effusions/empyema
4. Respiratory failure
5. Metastatic infections (meningitis, endocarditis, arthritis)
6. Lung abscess
7. ARDS, renal failure, multiple organ failure

8. Pneumothorax, especially with *Staph. aureus*
9. Thromboembolic disease
10. Pyrexia due to drug hypersensitivity.



Causes of Unresolved Pneumoniae

1. Incorrect microbiologic diagnosis
2. Inadequate dose or wrong choice of antibiotics
3. Endobronchial obstruction (poor local host defences)
4. Immuno-compromised states (disease or drugs)
5. Malignancy.



Causes of Recurrent Pneumoniae in the Same Segment

1. Foreign body
2. Neoplasia (benign or malignant)
3. Sequestration of lung
4. Bronchiectasis.

Special Characteristics of Various Pneumonias

Pneumococcal Pneumonia

Production of rusty sputum is characteristic and the patient may be icteric. It usually involves a lobe and pleuritic reaction is common.

Staphylococcal Pneumonia

This is common in cystic fibrosis and influenza. Multiple, thin-walled staphylococcal abscesses are common (pneu-matoceles). Pneumothorax is a complication. It occurs in extremes of age and in immunosuppressed patients.

Klebsiella Pneumoniae

Massive consolidation and excavation of upper lobe with expectoration of chocolate coloured sputum (brick red currant jelly). Lobes characteristically increase in size and it simulates tuberculosis.

Legionella Pneumonia

This is transmitted through infected water from cisterns, vapour or ventilation systems. Patient is toxic with haemoptysis; CNS or renal problems, myoglobinuria may be present. Diagnosis by serology or immunofluorescence.

Viral Pneumonia (Atypical Pneumonia)

Prodromal symptoms precede the onset of pneumonia by one week. Despite extensive radiological findings,



respiratory signs and symptoms are minimal. Haemoptysis and parapneumonic effusions are rare. Common viruses causing pneumonia are varicella, *H. simplex*, CMV, measles, influenza, adenovirus and RSV.

Actinomycosis

A. israelii, an anaerobe can cause suppurative pneumonia when local defences are impaired. Chest wall sinuses and empyema are common with the sinuses discharging pus containing sulfur granules.

Mycoplasma Pneumonia

Presents with dry cough, erythema multiforme, arthralgia, myalgia. Predilection to lower lobe. Cold agglutinins positive.

Pneumonia due to Chlamydia

C. psittaci causes psittacosis or ornithosis. Patient has pneumonia, systemic illness, hepatosplenomegaly. Patchy consolidation is common. Diagnosed by serology.

Nosocomial Pneumonia

Pneumonia developing in a patient who has been hospitalised for > 48 hours. Infection by *Staph. aureus*, *Pseudomonas* and anaerobes are common.

Factors predisposing to nosocomial pneumonia

1. Aspiration of nasopharyngeal secretions
2. Gastroesophageal aspiration
3. Bacteria introduced by interventions (endotracheal tube, ventilators, nebulisers).
4. Reduced host defences (steroid, post-operative state, anaesthesia)
5. Bacteraemia (sepsis).

Ventilator Associated Pneumonia

It is either due to non-multidrug resistant organisms or due to multidrug resistant organisms.



Clinical Features

- Fever with leukocytosis
- Increase in respiratory secretions
- Pulmonary consolidation
- New or changing radiographic infiltrate
- Set of diagnostic criteria – None



Complications

1. Death

Common Causes of Immunosuppression and Associated Lung Diseases

	Causes	Pathogens involved
Neutropenia	Cytotoxic drugs Agranulocytosis Acute leukaemia	<i>Staph aureus</i> Gram -ve bacteria <i>Candida albicans</i> and <i>Aspergillus fumigatus</i>
T-cell defect with or without B-cell defect	Lymphoma CLL Immunosuppressive drugs Bone marrow transplants Splenectomy	<i>Candida albicans</i> Tuberculosis <i>Pneumocystis carinii</i> CMV Gram -ve bacteria <i>Staph aureus</i> <i>Pneumococcus</i> <i>H. influenzae</i>
Antibody production	CLL Myeloma	<i>Pneumococcus</i> <i>H. influenzae</i>

2. Need for increased ventilatory support
3. Necrotising pneumonia

Pneumonia in Immunocompromised Host

This may be caused by *P. carinii*, *M. tuberculosis*. Onset is less rapid. Symptoms are more than signs. May be bilateral.

Pneumocystis Carinii Pneumonia

Occurs in immunocompromised hosts (AIDS, transplant recipients). It is an interstitial pneumonia. It presents with dry cough, tachypnoea, fever. Diagnosis is by clinical setting, sputum examination (methanamine silver stain) and lung tissue histopathology. Chest X-ray may be normal or show ground glass appearance; may spare lower zones.



Management

1. Appropriate antibiotics for 1–2 weeks as given in the tables.
2. Treatment of complications.
3. Ventilatory support when needed.
4. Prevention by pneumococcal vaccine (Pneumovax, 1 dose of 0.5 ml SC/IM repeated after 5–10 years).

Lung Abscess

It is a localised infectious suppurative necrosis of lung tissue of > 2 cm in diameter.

Predisposing Factors

1. Aspiration of infected material (oropharyngeal surgical procedures, dental sepsis, coma, drugs,



Empirical Antibiotic Treatment of Community—Acquired Pneumonia

Out-patients

Previously healthy (not on antibiotic in the past three months):

Clarithromycin 500 mg PO bid or azithromycin or doxycycline 100 mg PO bid

Comorbidities with history of antibiotics use in past three months:

Use respiratory fluoroquinolone moxifloxacin 400 mg PO od or gemifloxacin 320 mg PO od or levofloxacin 750 mg PO od **or**

A β -lactam amoxicillin 1 g tid or amoxicillin/clavulanate 2 g bid or ceftriaxone 1-2 g IV od or cefpodoxime 200 mg PO bid or cefuroxime 500 mg PO bid plus a macrolide

In-patients (non-ICU)

Moxifloxacin 400 mg PO or IV od or gemifloxacin 320 mg PO od or levofloxacin 750 mg PO or IV od

A β -lactam ceftriaxone 2 g IV od or cefotaxime 1-2 g IV tid or ertapenem 1 g IV od **plus** a macrolide

Oral clarithromycin or azithromycin or IV azithromycin 1 g once and then 500 mg od.

In-patients (ICU)

A β -lactam ceftriaxone 2 g IV od or cefotaxime 1-2 g IV tid or ampicillin/sulbactam 2g IV tid **plus**

Azithromycin or fluoroquinolone as mentioned above for in-patients (non-ICU).

Note:

Pseudomonas infection— an anti-pneumococcal, anti-pseudomonal β -lactam piperacillin/tazobactam 4.5 g IV qid, cefepime 1-2 g IV bid, imipenem 500 mg IV qid, meropenem 1 g IV tid, **plus** either ciprofloxacin 400 mg IV bid or levofloxacin 750 mg IV od **plus** an aminoglycoside either amikacin or tobramycin.

CA-MRSA (Community acquired methicillin resistant *Staphylococcus aureus*) Add linezolid 600 mg IV bid or vancomycin 1g IV bid.

Empirical Antibiotic Treatment of Health Care Associated Pneumonia

MDR (Multidrug-resistant) pathogens – patients without risk factors:

Ceftriaxone 2 g IV od, **or**

levofloxacin 750 mg IV od, moxifloxacin 400 mg IV od, ciprofloxacin 400 mg IV tid **or**

Ampicillin/sulbactam 3 g IV qid **or**

Ertapenem 1 g IV od

MDR(Multidrug-resistant) pathogens – patients with risk factors:

A β -lactam—Cefepime 2 g IV bid, ceftazidime 2g IV tid, **or**

Piperacillin/tazobactam 4.5 g IV qid, imipenem 500 mg IV qid

Or meropenem 1 g IV tid **plus**

A second agent active against gram-negative bacteria

An aminoglycoside –gentamycin/tobramycin/amikacin **or**

Levofloxacin 750 mg od or ciprofloxacin 400 mg IV tid **plus**

An agent active against gram-positive bacteria

Linezolid 600 mg IV bid or vancomycin 1 g IV bid

alcohol, anaesthesia, bulbar palsy, seizures, achalasia cardia).

2. Inadequately treated pneumonia.
3. Bronchial obstruction (tumour, foreign body).
4. Pulmonary infarction.
5. Septic emboli.

6. Spread of infection from adjacent organs, e.g. liver.
7. Infection of congenital or acquired cysts.

Abscesses vary in size and number. Aspiration abscesses are more common on right, reflecting the more vertical right bronchus. Posterior segment of right upper lobe or apical segment of either lower lobe are commonly involved.

Chronic abscesses are often surrounded by a reactive fibrous wall.

Common Organisms

Anaerobes, staphylococci, *Pseudomonas*, *Legionella* sp, *Streptococcus pneumoniae*, *M. tuberculosis*, *Nocardia* sp.



Clinical Features

Fever, malaise, weight loss, cough with copious, purulent sputum, haemoptysis, clubbing.

Position of the patient	Site of aspiration
1. Supine posture	Posterior segment of right upper lobe and apical segment of right or left lower lobe.
2. Prone position	Right middle lobe and left lingular lobe.
3. Sitting upright	Posterior or lateral basal segment of either lower lobe.



In epilepsy, any lobe can be involved because of bizarre posturing.



Differential Diagnosis

1. Cavitating lung cancer
2. Infected bulla or cyst
3. Pulmonary hamartoma
4. Cavitating pneumoconiosis
5. Infected hydatid cyst
6. Tuberculous, fungal, actinomycotic infections
7. Hiatus hernia.

Suspect and exclude malignancy in cavitory lesions involving the non-dependent portion of the lung such as right middle lobe or anterior segment of the upper lobe.



Investigations

1. *Chest X-ray*: Shows thick-walled cavity with fluid level which moves in decubitus film.
2. Sputum examination and culture.
3. Radioactive Indium-111 labelled leucocyte uptake.
4. CT-Chest.



Management

1. Appropriate antibiotics for 4–6 weeks.
2. Physiotherapy and postural drainage.
3. Rigid bronchoscopy for adequate suction of secretions from bronchial tree. Fibreoptic bronchoscope should be avoided as the suction channel is small and the flood of pus may drown the patient.
4. Intercostal tube drainage—*very rarely*.
5. *Surgery*: If there is failure of medical therapy in spite of bronchoscopic clearance, surgical resection is advised. Presence of obstructing carcinoma is an indication for surgery in addition to the definitive management according to the staging and general condition of the patient.

Pleural Effusion

Pleural effusion is the accumulation of serous fluid in the pleural cavity.

Mechanism of Pleural Fluid Formation

1. Elevation of venous pressure (rare in pure RV failure)
2. Decreased plasma oncotic pressure (except in congenital hypoalbuminaemia)

3. Increased capillary permeability due to local inflammation, toxins or vasoactive substances as occurs in collagen-vascular diseases, pancreatitis, pulmonary emboli and pneumonitis
4. Increase in pleural space oncotic pressure as a result of:
 - a. Protein leak through capillaries
 - b. Protein exudation due to local pleural inflammation.
 - c. Defective lymphatic resorption.
 When pleural space oncotic pressure approaches that of plasma (32 cm H₂O), fluid absorption is impaired.
5. Simple transfer of ascitic fluid across diaphragmatic defects and also through transdiaphragmatic lymphatics as occurs in cirrhosis and Meig's syndrome.
6. Increased negativity of pressure in the pleural space also results in pleural effusion as occurs in atelectasis
7. Obstruction of lymphatics.

Pleural fluid, on aspiration in normal persons is 3–20 ml. Normal protein content is below 1.5 gm/dl.



Causes of Pleural Effusion

Causes of Transudative Pleural Effusions

Congestive heart failure	Acute diuresis resulting in high PF/serum protein ratio
Hepatic hydrothorax	Usually associated with ascites
Nephrotic syndrome	Small, bilateral and subpulmonic
Peritoneal dialysis	Acute onset within 72 hours after dialysis- large right effusion
Hypoalbuminaemia	Anasarca – serum albumin < 1.5 gm/dL
Urinothorax	Associated with ipsilateral obstructive uropathy
Atelectasis	Small effusion caused by increased intrapleural negative pressure
Constrictive pericarditis	Due to pulmonary and systemic venous hypertension – bilateral
Trapped lung	As a result of remote inflammation
SVC obstruction	Due to venous hypertension or obstruction to thoracic lymph flow
Subarachnoid pleural fistula	CSF leak into pleural space after disc surgery
Myxoedema	Associated features of hypothyroidism

Exudates

1. *Neoplasms*: Metastatic disease, mesothelioma
2. *Infectious diseases*: Bacterial, viral, fungal, parasitic, tuberculous
3. Pulmonary embolism



4. *Collagen vascular diseases* (rheumatoid arthritis, SLE, Wegener's granulomatosis)
5. *Gastrointestinal disease* (oesophageal perforation, pancreatic disease, diaphragmatic hernia, intra-abdominal abscess, endoscopic sclerotherapy)
6. Uraemia
7. Meig's syndrome (ovarian fibroma, ascites, right sided pleural effusion)
8. *Drug-induced*: Bromocriptine, amiodarone, nitrofurantoin, dantrolene
9. Chylothorax, haemothorax
10. Ovarian hyperstimulation syndrome.

Features	Exudates	Transudates
Colour	Amber coloured	Colourless
Consistency	Sticky	Non-sticky
On shaking	Froth +	No froth
On standing	Clots	Does not clot
On aspiration	Slow flow	Flows fast
Specific gravity	> 1018	< 1018
Cells	+ +	a few lymphocytes
<i>Light's criteria</i>		
1. Pleural fluid protein/serum protein	> 0.5	< 0.5
2. Pleural fluid LDH/serum LDH	> 0.6	< 0.6
3. Pleural fluid LDH	> 2/3 of upper normal value of serum	< 2/3 of upper normal value of serum
Glucose	< 60 mg/dl	> 60 mg/dl
LDH	> 200 IU/L	< 200 IU/L

If the clinical suspicion is strongly in favour of transudate in a case of exudative effusion, do serum-pleural fluid protein gradient. Exudative criteria can be ignored if the gradient is > 3.1 gm/dl.

Pleural Fluid Analysis

If pleural fluid is found to be an exudate, the following tests should be done.

1. *Glucose level*: If < 60 mg/dl, consider the following conditions:
 - i. Bacterial infections (parapneumonic effusions).
 - ii. Rheumatoid pleural effusion (< 30 mg/dl)
 - iii. Malignancy
 - iv. Tuberculosis
 - v. Haemothorax
 - vi. Paragonimiasis
 - vii. Churg-Strauss syndrome.

Patients with malignant disease of pleura and a low sugar level have a positive pleural cytology or biopsy or both and they have a poor prognosis of less than 2 months. Sugar level more than 80 mg% suggests SLE.

2. *Amylase level*: Elevated in:
 - i. Pancreatic pleural effusion (pseudocyst of pancreas, pancreatitis)
 - ii. Oesophageal rupture
 - iii. Malignancy (salivary amylase).
 In malignancy and oesophageal rupture only salivary amylase is elevated and not pancreatic amylase.
3. *Total WBC count*: If TC > 1000/mm³, the fluid is an exudate. If TC > 10,000/mm³, consider
 - i. Empyema
 - ii. Parapneumonic effusion
 - iii. Pancreatitis
 - iv. Pulmonary embolism
 - v. Collagen vascular diseases
 - vi. Malignancy
 - vii. Tuberculosis.

4. Differential cell count

- i. *Increased neutrophils*
 - Pulmonary infection
 - Pulmonary embolisation
 - Intra-abdominal abscess
- ii. *Increased Lymphocytes*
 - Tuberculosis
 - Malignancy
 - Chylothorax
 - Lymphoma
 - Yellow nail syndrome
 - Sarcoidosis
 - Rheumatoid disease
 - Acute lung rejection
- iii. *Increased eosinophils*

a. With peripheral eosinophilia

- Hodgkin's disease
- Fungal infection
- Parasitic (paragonimiasis)
- Benign asbestos pleural effusion
- Polyarteritis nodosa
- Tropical eosinophilia
- Churg-Strauss syndrome.
- Drugs—dantrolene, nitrofurantoin

b. Without peripheral eosinophilia

- Trauma
- Pulmonary infarction
- Pneumothorax
- Haemothorax
- Rarely in carcinoma.

- iv. *Mesothelial cells*: Presence of mesothelial cells is against the diagnosis of tuberculosis and diagnostic of mesothelioma and adenocarcinoma.

5. *pH of the pleural fluid*: If pleural fluid pH is < 7, tube thoracostomy is indicated. If the pH is low, consider
 - i. Complicated parapneumonic effusion
 - ii. Systemic acidosis
 - iii. Oesophageal rupture



- iv. Rheumatoid pleurisy
 - v. Tuberculosis (TB pleuritis)
 - vi. Malignancy of pleura
 - vii. Haemothorax
 - viii. Paragonimiasis
 - ix. Lupus pleuritis
 - x. Urinothorax.
6. High pleural fluid to serum ratio of IgG, IgA, IgM suggests malignancy.
 7. Increased gamma interferon is found in tuberculous effusion > 140 pg/ml.
 8. Pleural fluid adenosine deaminase (large form) >70 U/L indicates tuberculous effusion and a value of < 40 U/L is against the diagnosis.
If the small form of ADA is elevated, it is suggestive of lymphoma.
 9. Pleural fluid should be sent for Gram's stain and culture, smear for AFB, culture for AFB.
 10. Pleural fluid cytology should be done to find out malignant cells.



Clinical Features

Pleuritic chest pain (before effusion develops); dyspnoea (the degree of which depends on the rate and the size of accumulation); tracheal and mediastinal shift to the opposite side; diminished or absent breath sounds and stony dull percussion note; aegophony and bronchial breath sounds just above the level of effusion due to the relaxed lung.



Investigations

Chest X-ray

- Minimal amount of fluid that can be detected in the PA view is 300 ml. Smaller quantities of fluid are detected in lateral decubitus position (in this position, fluid layers along the dependent chest wall).
- Dense uniform opacity in the lower and lateral parts of the haemothorax shading off above and medially into translucent lung (Ellis 'S' shaped curve).
- Tracheal and mediastinal shift to the opposite side (fluid > 1500 cc). When mediastinal shift does not occur, think of parenchymal collapse, previous mediastinal fixation or mesothelioma (Figs 4.37 and 4.38).
- Obliteration of costophrenic and cardiophrenic angles.
- Fluid that is located laterally may result in a smooth, semicircular opacity abutting the pleural surface mimicking a mass lesion.

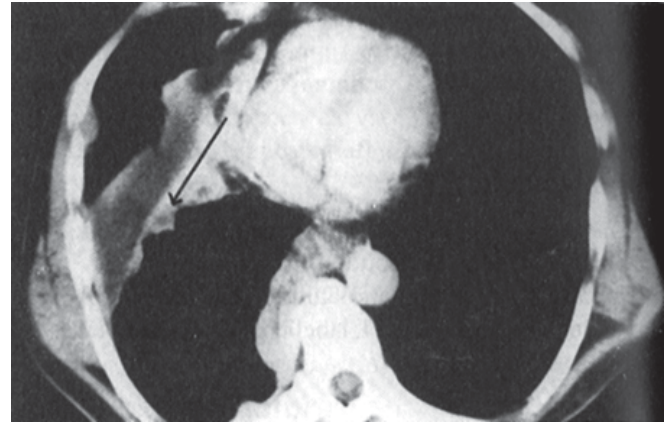

Fig. 4.37: CT scan—irregular, lobulated appearance of pleural mesothelioma

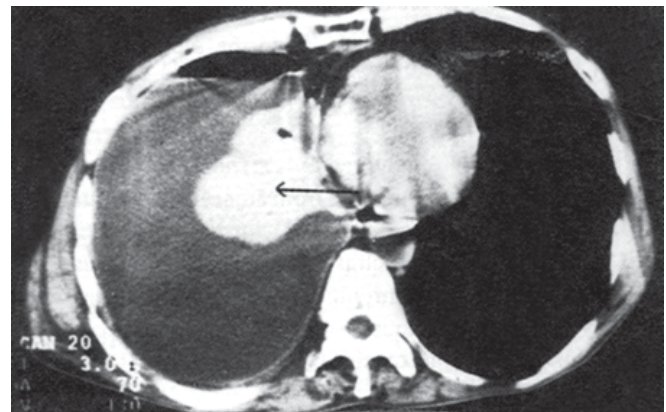

Fig. 4.38: CT mediastinal window—pleural effusion right side with passive lung collapse

- There may be a collection in interlobar fissure (vanishing tumour of lung) which disappears on treatment with diuretics.
- Subpulmonic effusion of about 1000 ml may appear only as an elevated diaphragm. X-ray in lateral decubitus position confirms the diagnosis by layering the fluid and reveals the true diaphragmatic shadow.

Parapneumonic Effusion

It is a pleural effusion associated with bacterial pneumonia, lung abscess or bronchiectasis.

Complicated parapneumonic effusions are those effusions which require tube thoracostomy for their resolution.

Empyema is pus in pleural cavity and this term is reserved for effusions in which the Gram's stain of the pleural fluid is positive.

In a patient with bacterial pneumonia, lateral decubitus film may show the presence of free pleural fluid.



If the fluid separates the lung from the chest wall by > 1 cm in the decubitus film, a diagnostic thoracentesis should be performed.

Any of the following is an indication for *tube thoracostomy* in patients with parapneumonic effusion.

1. Presence of gross pus in pleural space
2. Organisms visible on Gram's stain of the pleural fluid
3. Pleural fluid glucose level < 50 mg/dl
4. Pleural fluid pH below 7.0 and 0.15 units lower than arterial pH.

If the pH is > 7.3 , antibiotics alone are sufficient. If the pH is < 7.1 , glucose < 40 mg/dl, LDH > 1000 units, and if there is presence of loculation, tube thoracostomy is indicated. If the pH is between 7.1 and 7.3 and if the effusion is free flowing, antibiotic therapy should be given along with therapeutic pleural aspiration.

Immediate intervention is a must in parapneumonic effusion as it may get loculated within a matter of hours. In loculated effusions, streptokinase 2,50,000 units or urokinase 100,000 units should be injected intrapleurally to dissolve fibrin membranes. If there is no response, decortication or open drainage can be tried.

Empyema Thoracis

Empyema means presence of pus in the pleural cavity.



Causes

Non-traumatic

1. Direct extension of infection from adjacent site (bronchiectasis, lung abscess, pneumonia)
2. Obstruction to a bronchus (foreign body, lung cancer)
3. Extension from subphrenic abscess, liver abscess when they rupture into pleura
4. Extension of spine or chest wall infections.

Traumatic

1. Surgical trauma (instrumentation, oesophageal rupture)
2. Penetrating trauma to the chest—gun shot wounds, stab injury.

Organisms

Gram-positive organisms are common when empyema develops secondary to pneumonia.

Gram-negative organisms are common when empyema develops secondary to gastro-oesophageal and thoracic surgery.

In childhood, staphylococci are commonly encountered.

Predisposing Factors

Alcohol, diabetes mellitus, tuberculosis, carcinoma, heroin addicts, steroid therapy.



Clinical Features

Clinical manifestations are fever, malaise, loss of weight, dyspnoea, features of pleural effusion, finger clubbing and intercostal tenderness.

Empyema usually points at an intercostal space, close to the sternum where chest wall is thinnest.



Investigations

1. *Chest X-ray*—shows fluid in pleural space; sometimes loculated effusion is seen as a D-shaped shadow in lateral film. Air fluid level suggests an associated pneumothorax
2. Indium-111 leucocyte scanning for localisation of pus
3. Pleural fluid analysis shows thick pus, pH < 7.2 , LDH > 1000 U/L, glucose < 60 mg/dl and Gram's stain demonstrates organisms.



Treatment

1. Control of infections with appropriate antibiotics (aminoglycosides penetrate less well or they may be inactivated by the infected pleural fluid)
2. Adequate drainage of pus by:
 - a. Using a wide bore needle/Abram's punch biopsy needle (for taking biopsy also). Aspiration may be required daily or 2–3 times per week.
 - b. Closed tube thoracostomy at the most dependent part of empyema.
Tube thoracostomy fails
—if the pus is too thick,
—if a bronchopleural fistula develops
—if the pus is loculated.
 - c. *Thoracostomy with decortication*: This procedure is done if tube thoracostomy fails and when the patient is surgically fit. The fibrous wall (rind, peel, cortex) of empyema cavity is stripped off the parietal and visceral pleura.
 - d. Open drainage with rib resection is done if the patient is unfit for decortication.

Malignant Effusions

Malignant effusions commonly occur in carcinoma of lung, breast and lymphomas. Effusions are usually haemorrhagic and rapidly accumulating.



Chylothorax

When thoracic duct is disrupted and chyle accumulates in pleural space, chylothorax occurs. When the lesion is above D₅ level, a left sided chylothorax occurs and if the lesion is below D₅ level, a right sided chylothorax results.



Causes

1. Trauma
2. Tumour-lymphomas
3. Tuberculosis
4. Lymphangioliomyomatosis
5. Congenital absence of thoracic duct
6. Yellow nail syndrome
7. Filariasis

Chylous fluid is milky and has a triglyceride level of > 110 mg/dl; CT may show mediastinal nodes. Detection of dye or radio activity after the patient eats butter with a lipophilic dye (sudan III) or radio-iodine labelled triglyceride confirms the diagnosis.

Chylothorax should be differentiated from pseudo-chylous effusion. In chronic effusion due to TB or rheumatoid arthritis, fluid rich in cholesterol mimicking chyle accumulates. Addition of ethylether to a sample of the turbid pleural fluid clears it by dissolving triglyceride if it is a chylous effusion.

Demonstration of cholesterol crystals on a smear + history + a negative dye or radio iodine test can differentiate pseudo-chylous effusion from chylothorax.

Treatment of choice is pleuroperitoneal shunt. Tube thoracostomy is contraindicated as it may lead to malnutrition and immunodeficiency.

Haemothorax

Presence of blood in pleural cavity is called haemothorax. If the haematocrit of the pleural fluid is greater than 50% that of the peripheral blood, the patient has a haemothorax.

Haemothorax is potentially lethal and warrants immediate surgical intervention.



Causes

- Trauma
- Rupture of a blood vessel
- Tumour

Recurrent pneumothorax (due to rupture of vascular adhesions between visceral and parietal pleurae).

If the pleural haemorrhage exceeds 200 ml/hour, thoracotomy should be considered.

Pleural Effusion in AIDS

This may be due to

1. Kaposi's sarcoma
2. Parapneumonic effusion
3. Tuberculosis
4. Cryptococcosis
5. Lymphoma.



Causes of Bilateral Effusions

1. With cardiomegaly
 - CCF
2. Without cardiomegaly
 - Pulmonary infarction
 - Hypoalbuminaemia
 - Malignancy.



Causes of Right Sided Effusions

1. Fluid retaining states (CCF, CRF, cirrhosis of liver with portal hypertension, etc.)
2. Subdiaphragmatic causes (amoebic liver abscess, subphrenic abscess)
3. Meig's syndrome
4. Thoracic duct involvement below D₅ level.



Causes of Left Sided Effusions

1. Pancreatitis
2. Pericardial inflammation
3. Oesophageal rupture
4. Left sided subdiaphragmatic abscess
5. Thoracic duct involvement above D₅ level.



Management

1. Treat the underlying cause.
2. If the effusion is symptomatic, pleural aspiration should be done. Do not aspirate more than 1000 ml of fluid in one sitting as it may lead to re-expansion of pulmonary oedema.
3. Intercostal drainage for empyema, haemothorax (to find out rate of blood loss)
4. Pleurodesis (using tetracycline, bleomycin, talc) for malignant effusions.

Pneumothorax

This is the presence of air in the pleural space.

Spontaneous Pneumothorax

Spontaneous pneumothorax is one which occurs without antecedent trauma to the thorax.

- Primary spontaneous pneumothorax*: There is no underlying lung disease or sub-clinical disease and 50% recurs. These are due to rupture of apical, sub-pleural blebs of 1–2 cm in diameter. More common in tall, thin individuals, especially smokers.
- Secondary spontaneous pneumothorax*: There is underlying lung disease like COPD, bronchial asthma, tuberculosis, pneumonia, staphylococcal lung abscess, carcinoma lung, cystic fibrosis, fibrosing alveolitis, histiocytosis X, Marfan's syndrome, Ehlers-Danlos syndrome.

Traumatic Pneumothorax

This occurs following penetrating or non-penetrating chest injuries.

Deceleration injury, rib fractures, oesophageal rupture, abdominal trauma, invasive procedures like transthoracic needle aspiration, thoracentesis, insertion of central intravenous catheters, intercostal nerve block, liver biopsy are leading causes for traumatic pneumothorax.

Types

- Closed*: The communication between the lung and the pleura closes spontaneously as the lung deflates and does not reopen. When the air is reabsorbed, the lung gradually re-expands.
- Open*: The communication is generally with a bronchus (bronchopleural fistula) and does not close when the lung collapses. Air pressure in the pleural cavity equals that of atmospheric pressure and the lung does not re-expand. Infection is common.
- Tension pneumothorax*: The communication between the pleura and the lung persists and it acts like a one way valve allowing air to enter the pleura during inspiration and coughing but prevents it from escaping. This usually occurs during mechanical ventilation or resuscitative efforts. This must be treated as a medical emergency.

There is positive pressure in the pleural cavity throughout the respiratory cycle.



Clinical Features

Onset is sudden; progressively increasing dyspnoea, cyanosis, distended neck veins, mediastinal shift, hypotension, diminished breath sounds, hyper-resonant percussion note, diminished VF, VR.

Mediastinal emphysema may be detected by hearing *mediastinal crunch* (Hamman's sign) co-existent with cardiac systole and diastole.

Catamenial Pneumothorax

It is a rare condition occurring in women aged more than 25–30 years. Repeated attacks on the right side are common in association with menstruation. Attacks usually occur within 48 hours of onset of menstruation. This is treated by ovulation suppressing drugs, surgical exploration or pleurodesis.



Complications

Acute: Tension pneumothorax, bilateral pneumothorax, acute respiratory failure, haemothorax and pyothorax. Bilateral pneumothorax is rare and cannot be detected unless a chest X-ray is taken. Haemothorax is potentially lethal; at least 200 ml of blood should be there to obscure costophrenic angle on an X-ray.

Late: Failure to re-expand and recurrence.



Investigations

Chest X-ray: Pneumothorax is evident as an area devoid of lung markings peripheral to the edge of the collapsed lung. It is better demonstrated in an expiratory film when the lung is deflated (Fig. 4.39).



Management

- Small pneumothorax < 20% of hemithoracic volume can be left alone. Weekly X-ray is taken till full expansion occurs. Rate of absorption is 1.25% of hemithoracic volume per day.

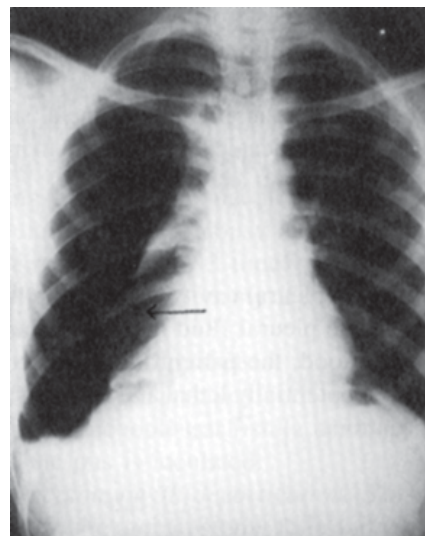

Fig. 4.39: Pneumothorax right side with passive lung collapse



Management

1. Treat the primary cause in diseases where cause is known
2. Bronchodilators and prophylaxis for infection
3. Avoid exposure to allergens in extrinsic allergic alveolitis
4. The drugs of choice are immunosuppressives (steroids, cytotoxic drugs).

Prednisone in a dose of 1 to 1.5 mg/kg/day for 2 to 3 weeks followed by a maintenance dose of 15–20 mg on alternate days. If the patient does not respond, cyclophosphamide 100 to 120 mg/day is started. Monitor the response to treatment with chest X-ray, ABG and lung function tests.

Bronchogenic Carcinoma

Lung cancer remains the number one cause of cancer deaths among men. Heavy smokers (> 25 cigarettes/day) experience a risk that is 20 times greater than that of non-smokers. Five percent of cancer deaths are due to passive smoking.

Common Types of Lung Cancer

1. Squamous cell carcinoma or epidermoid (50%)
 2. Small cell carcinoma or oat cell carcinoma (25%)
 3. Large cell carcinoma (15%)
 4. Adenocarcinoma (10%)
- Squamous cell and small cell carcinomas are centrally placed tumours; Large cell and adenocarcinoma are peripherally placed tumours.

Predisposing Factors

1. Smoking
2. Asbestos exposure
3. Occupational hazards (mining, industrial gases, arsenic, chromium, nickel, radon, vinyl chloride, synthetic rubber)
4. Air pollution (sulphur dioxide, carbonaceous particulate matter)
5. Familial predisposition
6. History of COPD, diffuse pulmonary fibrosis, scleroderma, sarcoidosis
7. Less intake of fruits and vegetables containing beta carotene which is a precursor of vitamin A. Vitamin A deficiency predisposes to carcinoma lung

Other dietary factors – Selenium, vitamin E and C deficiency, High dietary fat/cholesterol intake.
8. Individuals with increased aryl hydrocarbon hydroxylase (genetically determined) which converts

hydrocarbons to more active carcinogens, are at a risk of developing lung cancer.



Clinical Features

Thoracic Manifestations

- Cough, haemoptysis, dyspnoea (due to collapse or pleural effusion) pleuritic chest pain, recurrent and slowly resolving pneumonia, fixed monophonic wheeze.
- *Pancoast tumour (superior sulcus tumour)*: It presents with pain in shoulder and arm, unilateral Horner's syndrome, small muscle wasting of the hand, rib and vertebral erosion and is usually due to a squamous cell carcinoma.
- Symptoms due to SVC obstruction, more common with small cell carcinoma.
- Recurrent laryngeal nerve palsy and dysphagia may also occur.

Extrathoracic Manifestations

Symptoms due to blood borne metastasis such as seizures, focal neurological deficits, jaundice, bone pain are common.

Paraneoplastic Manifestations

1. *Endocrine*
 - a. Inappropriate ADH secretion (small cell carcinoma)
 - b. Ectopic ACTH secretion (small cell carcinoma)
 - c. Hypercalcaemia (squamous cell carcinoma)
 - d. Carcinoid syndrome
 - e. Gynaecomastia.
2. *Neurological and muscular*
 - a. Myopathy, myositis
 - b. Neuropathy
 - c. Dementia
 - d. Cerebellar degeneration
 - e. Eaton-Lambert syndrome (Myasthenic syndrome).
3. *Others*
 - a. Hypertrophic pulmonary osteoarthropathy
 - b. Nephrotic syndrome
 - c. Weight loss.



Investigations

To Confirm Diagnosis

- a. *Chest X-ray*: It may show unilateral hilar enlargement, peripheral opacity, collapse, pleural effusion, rib erosions, mediastinal widening, elevated hemidiaphragm (due to phrenic nerve palsy) (Fig. 4.40).

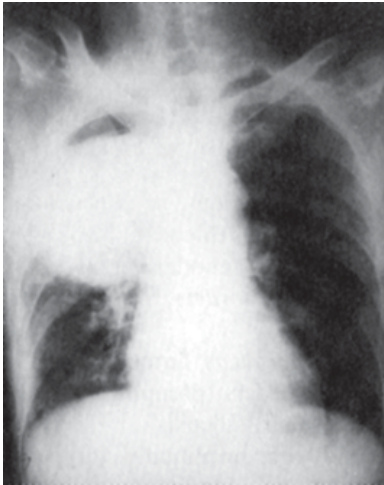

Fig. 4.40: Right lung—mass lesion

- b. *Bronchoscopy*: Central tumours may be visualised. Bronchial washings can be obtained to find out malignant cells.
- c. *Sputum cytology*: Microscopic examination of sputum and bronchoscopic brushings.
- d. *Biopsy and histopathological examination*:
 - i. Biopsy of the parenchymal lesion by bronchoscopy or percutaneous biopsy.
 - ii. Pleural biopsy in the presence of pleural effusion.
 - iii. Lymph node biopsy.

In the Presence of Metastasis

- a. Liver function tests
- b. Isotope bone scan
- c. Mediastinoscopy
- d. USG abdomen
- e. CT of brain, abdomen and thorax (Fig. 4.41).

Squamous Cell or Epidermoid Carcinoma

Central tumour; it may cavitate; usually well-differentiated; radiosensitive.

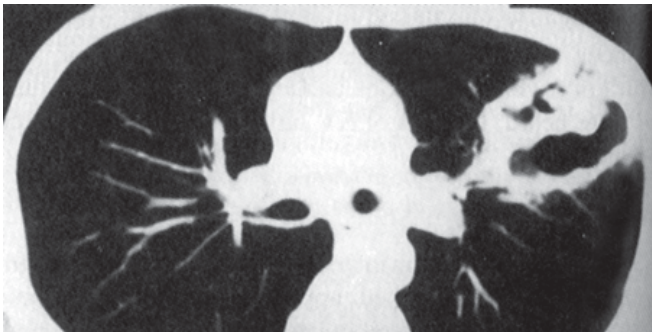

Fig. 4.41: CT scan—irregular thick-walled cavity in left lung (carcinoma)

Small Cell or Oat Cell Carcinoma

APUD cell origin; most malignant type; usually widely spread before diagnosis; central tumour; paraneoplastic manifestations common; chemotherapy is beneficial.

Large Cell Carcinoma

Peripheral tumour; less well-differentiated; metastasise early.

Adenocarcinoma

Peripheral tumour; may present as pneumonic consolidation; associated with asbestosis. *Not related to smoking*. Alveolar cell carcinoma, one of the subtypes, is associated with profuse, mucoid sputum production (bronchorrhoea).



Management

Small Cell Lung Cancer (SCLC)

1. Limited stage—For patients with good performance status
Combination chemotherapy + chest radiotherapy
2. Extensive stage (good performance status)
Combination chemotherapy
3. All stages—Complete tumour responders
Prophylactic cranial radiotherapy
4. Poor performance status—All stages.
Modified dose combination chemotherapy and palliative radiotherapy.

Non-small Cell Lung Cancer

Resectable (stage I, II, IIIa and selected T₃, N₂ lesions)

- Surgery
- Radiotherapy for 'non-operable' patients
- N₂—postoperative radiotherapy.

Non-resectable (N₂, M₁)

- *Confined to chest*: High dose chest radiotherapy (RT) if possible
- *Extrathoracic*: RT to symptomatic local sites; chemotherapy for good performance status patients.

All Patients

1. Radiotherapy for brain, spinal cord metastasis, nerve palsies, obstructed airway, haemoptysis in non-small cell cancer, in small cell cancer resistant to chemotherapy, SVC obstruction, chest wall invasion, bone metastasis
2. Appropriate diagnosis and treatment of other medical problems
3. To stop smoking.



Prognosis

Non-small cell carcinoma: 2-year survival rate without spread—50%; with spread 10%.

Small cell carcinoma: 1 year in treated and 3 months in untreated patients.

Mediastinal Mass

Mediastinum is divided into four compartments with reference to the lateral chest radiograph.

1. *Superior mediastinum:* Above the line joining D₅ vertebra and the upper end of the body of the sternum.
2. *Anterior mediastinum:* Bounded by thoracic inlet superiorly, sternum anteriorly, anterior pericardium posteriorly. It contains upper oesophagus, trachea, thymus, aortic arch, adipose tissue and lymphatics.
3. *Middle mediastinum:* Contains pericardium and its contents, lower part of trachea, carina, main bronchi and associated lymph nodes.
4. *Posterior mediastinum:* It reaches from posterior pericardium to vertebral column, posterior rib including paravertebral gutters. It contains oesophagus, descending aorta, sympathetic ganglia and peripheral nerves.

Common Mediastinal Masses

Superior Mediastinum

1. Thymic tumour
2. Retrosternal goitre
3. Dermoid cyst
4. Lymphoma
5. Aortic aneurysm.

Anterior Mediastinum

1. Thymoma
2. Hodgkin's and non-Hodgkin's lymphomas
3. Aortic aneurysm
4. Pericardial, bronchogenic, thymic cysts
5. Intrathoracic goitre
6. Mesenchymal tumours (lipoma, fibromas, lymphangiomas and their malignant counterparts).

Middle Mediastinum

1. Pericardial cyst, bronchogenic cysts
2. Lymphomas
3. Granulomatous lesions (TB, sarcoidosis, histoplasmosis)
4. Carcinoma bronchus
5. Hiatus hernia
6. Metastasis.

Posterior Mediastinum

1. Neurogenic tumours
2. Paravertebral abscess
3. Alimentary tract duplications, enteric cyst
4. Aortic aneurysm.

Symptoms and Signs

1. Compression of trachea—stridor, dyspnoea, brassy cough, collapse
2. Compression of oesophagus—dysphagia
3. Phrenic nerve involvement—diaphragmatic paralysis
4. Left recurrent laryngeal nerve involvement—hoarseness of voice, bovine cough
5. SVC obstruction—headache, facial and arm oedema, cyanosis, non-pulsatile neck vein distension, dilated anastomotic veins of the chest
6. Sympathetic trunk involvement—Horner's syndrome
7. Pericardial involvement (effusion or inflammation).



Investigations

1. *Chest X-ray:* Benign tumours are well-circumscribed and malignant tumours show irregular margin and present with mediastinal widening. Fluoroscopic examination of hemidiaphragm is to be done to rule out phrenic nerve palsy.
2. *CT scan:* Very useful in defining mediastinal masses (Figs 4.42 and 4.43).
3. *MRI scan:* It can image in any plane and it has the ability to differentiate between blood vessels and soft tissue. It is also useful in detecting spinal cord

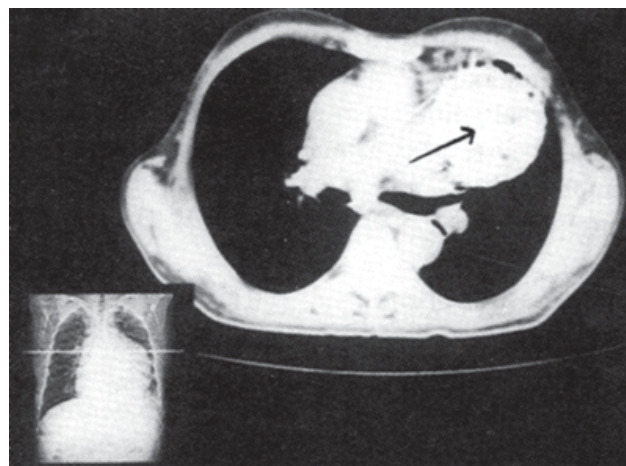

Fig. 4.42: CT mediastinal window— anterior mediastinal mass

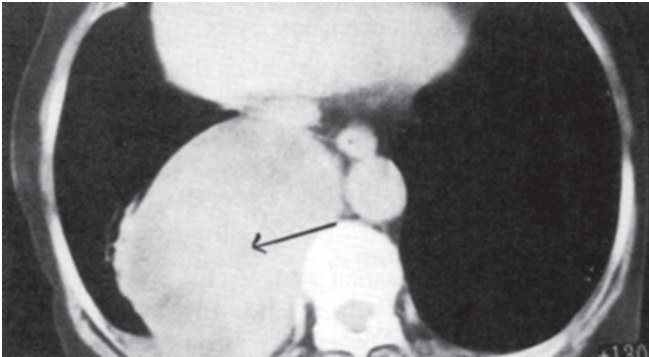

Fig. 4.43: CT mediastinal window—posterior mediastinal mass (neurofibroma)

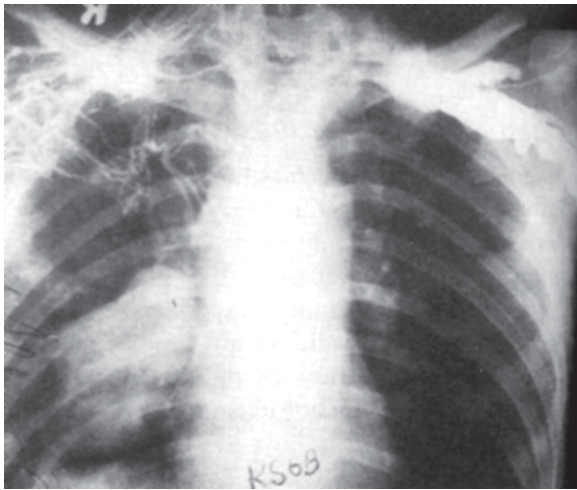

Fig. 4.44: Venogram—extensive collaterals in SVC obstruction due to mass lesion

extension in a posterior mediastinal tumour (Fig. 4.44).

4. *Mediastinoscopy:* This is helpful in taking biopsy of lymph nodes from anterior mediastinum.
5. *Investigations to rule out other causes:* Bronchoscopy for carcinoma bronchus, thyroid scintigraphy, barium swallow, angiography.



Management

Benign Tumours

Surgical removal (cysts may get infected; benign tumours may turn malignant).

Malignant Tumours

- Treatment for lymphoma or leukaemia
- Radiotherapy for malignant thymoma
- Radiotherapy for nodes from carcinoma lung

- Radiotherapy alone or radiotherapy + chemotherapy for SVC and tracheal obstructions.
- Treatment of other primary causes (TB, histoplasmosis, etc.)

Acute Respiratory Distress Syndrome (ARDS)

Acute respiratory distress syndrome is a clinical syndrome of severe dyspnoea of rapid onset, hypoxaemia and diffuse pulmonary infiltrates leading to respiratory failure.

Diagnostic criteria for ARDS:

1. Acute onset
2. X-ray shows bilateral alveolar infiltrates
3. $\text{PaO}_2/\text{FiO}_2 = \geq 200$ mm Hg
4. PCWP < 18 mm of Hg (pulmonary capillary wedge pressure)

ARDS consists of three phases:

- A. *Exudative phase:* This phase lasts for about seven days. Injury involving alveolar capillary endothelial cells and type I pneumocytes cause exudation of highly proteinaceous fluid into the interstitial and alveolar spaces.
The oncotic pressure is normal.
- B. *Proliferative phase:* This phase lasts for about two weeks (8th-21st days) This phase is characterised by prominent interstitial inflammation and early fibrosis.
- C. *Fibrotic phase:* Many ARDS patients recover lung function four weeks after initial lung injury. Some will enter a fibrotic phase that may require long-term support on mechanical ventilation.

Clinical Settings Associated with the Development of ARDS

1. Aspiration of gastric contents
2. Pneumonia
3. Severe sepsis
4. Major trauma
5. DIC
6. Near drowning
7. Inhalation of smoke, irritant (oxygen) or toxic gases
8. Fat or air embolism
9. Massive burns
10. Cardio-pulmonary bypass
11. Pancreatitis
12. Narcotic administration
13. Pre-eclampsia



14. Head injury, increased ICT
15. Shock, sepsis
16. Radiation, drugs
17. Tumour lysis syndrome
18. Malaria.



Clinical Features

Tachypnoea followed by dyspnoea, cyanosis, extensive crackles over both lung fields.



Investigations

1. *ABG analysis*: Demonstrates hypoxaemia.
2. *Chest X-ray*: Diffuse, extensive alveolar shadowing bilaterally and more peripherally.
3. *Haemodynamic measurements*: Pulmonary artery occlusive pressure < 18 mm Hg; PAOP > 18 mm Hg suggests hydrostatic pulmonary oedema.
4. *Pulmonary compliance*: Decreased to < 30 ml/cm H₂O.
5. Investigations to determine specific cause.



Management

1. Treat the cause
2. Oxygen inhalation
3. Respiratory support with PEEP (PEEP at levels from 5–15 cm H₂O should be applied when positive pressure ventilation cannot maintain a PaO₂ > 55–60 mm Hg using an FiO₂ of 0.6 or less).

PEEP helps in the redistribution of capillary blood flow resulting in improved V/Q matching and the recruitment of previously collapsed alveoli and prevention of their collapse during exhalation. This results in improved PaO₂ which helps in the reduction of FiO₂. Improvement of lung function occurs in 30–60 minutes.

Oxygenation can also be improved by increasing mean airway pressure with inverse ratio ventilation (Inspiration: Expiration ratio > 1:1). Prone position ventilation can also be tried.

4. Sedation and muscle paralysis to prevent the patient from fighting the ventilator and oxygen utilisation.
5. If cardiac output cannot be preserved, inotropic agents, vasodilators or both can be used.
6. Cyclo-oxygenase inhibitors, protease inhibitors, anti-oxidant therapy, antitumour necrosis factor or interleukin-1 receptor antagonists are being evaluated.
7. Nitric oxide inhalation (reduces pulmonary artery pressure and improves oxygenation).

Mechanical Ventilation

Ventilators are specially designed pumps that can support the ventilatory function of the respiratory system and improve oxygenation through application of high oxygen content and positive pressure.

Indications for Mechanical Ventilation

1. Respiratory rate > 35/minute
2. Inspiratory force < 25 cm of H₂O
3. Vital capacity < 10–15 ml/kg
4. PaO₂ < 60 mm Hg with FiO₂ > 60 %
5. PaCO₂ > 50 mm Hg with pH < 7.35
6. Absent gag or cough reflex.

Modes of Ventilation

A volume-cycled ventilator is used in most clinical circumstances. These ventilators deliver a pre-set tidal volume irrespective of change in the lung compliance. Hence, when there is a noncompliant lung, baro-trauma can be caused to the lung. To protect the patient against this undesirable side effect, a pressure limit is set.

Control Mode Ventilation (CMV): This mode is selected in a patient who does not have any spontaneous breathing as in coma or paralysis. The required volume and rate is set and delivered by the ventilator. The patient is not allowed to take spontaneous breath in this mode.

Assist Control Mode Ventilation (ACMV): This is the commonly used mode of ventilation in patients who need assisted ventilation. In this mode, the required tidal volume and respiratory rate are set and delivered by the ventilator. In addition, all spontaneous breathing effort by the patient are assisted by the ventilator. Ventilator-initiated breaths are delivered automatically when the patient's spontaneous breath rate falls below the selected back-up rate.

Synchronised Intermittent Mandatory Ventilation (SIMV): This mode is maintenance as well as weaning mode. Here, the required tidal volume and the respiratory rate are set and delivered by the ventilator in synchrony with the patient's own respiratory effort. Potential advantages of SIMV include less respiratory alkalosis, fewer adverse cardiovascular effects due to lower intrathoracic pressures, less requirement for sedation and paralysis, maintenance of respiratory muscle function, and facilitation of long-term weaning.

Pressure Support Ventilation (PSV): This mode augments each patient triggered respiratory effort by specified amount of preset level of positive airway pressure



(5-50 cm of H₂O). This mode is primarily to augment spontaneous respiratory efforts during IMV modes of ventilation or during weaning trials.

Continuous Positive Airway Pressure (CPAP): CPAP is used to deliver air via a nasal or oral mask. Nasal continuous positive airway pressure (nCPAP) is the current treatment of choice for most patients with obstructive sleep apnoea-hypopnoea syndrome (OSAHS). nCPAP pneumatically splints open the upper airway and prevents collapse. CPAP is applied in spontaneously breathing patient before weaning from mechanical ventilation. Bilevel positive airway pressure (BIPAP) is more expensive than simple CPAP and can be used to treat patients with OSAHS and in patients who do not tolerate high levels of CPAP. All non-invasive positive pressure or mechanical ventilation devices may induce dryness of the airway, nasal congestion, rhinorrhoea, epistaxis, nasal bridge abrasions, skin reactions to the mask and aerophagia.

Positive End Expiratory Pressure (PEEP): PEEP is defined as the maintenance of positive airway pressure at the end of expiration. It can be applied in the spontaneously breathing patient in the form of CPAP or to the patient who is receiving mechanical ventilation. PEEP usually increases lung compliance by opening the alveoli and oxygenation while decreasing the shunt fraction and ventilation perfusion mismatch. PEEP is used primarily in patients with hypoxic respiratory failure (e.g. ARDS, cardiogenic pulmonary oedema). Low levels of PEEP (3-5 cm of H₂O) is useful in patients with COPD to prevent dynamic airway collapse from occurring during expiration. The main goal of PEEP is to achieve a PaO₂ greater than 55-60 mm Hg with an FiO₂ of 60%. Patients who receive significant levels of PEEP (i.e. > 10 cm H₂O) should not have their PEEP removed abruptly since it can result in collapse of distal lung units. PEEP should be weaned in 3-5 cm H₂O increments while oxygenation is monitored closely.

Inverse ratio ventilation (IRV): It uses an inspiratory-to-expiratory ratio \geq 1:1 instead of the normal 1:2-1:3 to stabilise terminal respiratory units (alveolar recruitment) and to improve gas exchange primarily for patients with ARDS. The goals of IRV are:

1. To decrease peak airway pressures
2. To maintain adequate alveolar ventilation
3. To improve oxygenation

Indication for IRV: A PaO₂ less than 60 mm Hg with FiO₂ of greater than 60% and peak airway pressures greater than 40-45 cm of H₂O or PEEP > 15 cm of H₂O.

Most patients need heavy sedation and often muscle paralysis during the implementation of IRV.

Non-invasive Mechanical Ventilation: Non-invasive intermittent positive pressure ventilation (NIPPV) increases pH, reduces PaCO₂, reduces the severity of breathlessness in the first 4 hours of treatment, and decreases the length of hospital stay. Intubation rate is reduced by this intervention.

However, NIPPV is not appropriate for all patients.

Indications

1. Moderate to severe dyspnoea with the use of accessory muscles and paradoxical abdominal motion
2. Moderate to severe acidosis (pH < 7.35) and hypercapnia (PaCO₂ > 6 kPa, 45 mm of Hg).
3. Respiratory frequency > 25 breaths/minute.

Contraindications

1. Respiratory arrest
2. Cardiovascular instability (Hypotension, arrhythmias, MI)
3. Impaired mental status, somnolence, non-cooperative patients
4. High aspiration risk—viscous or copious secretions
5. Recent facial or gastro-oesophageal surgery
6. Craniofacial trauma, fixed nasopharyngeal abnormalities
7. Extreme obesity

Complications of Mechanical Ventilation

1. Airway malpositioning and occlusion
2. Acute increase in peak airway pressure
 - a. Pneumo/haemothorax
 - b. Occlusion of patient's airway
 - c. Bronchospasm
 - d. Accumulation of condensate in ventilator circuit
 - e. Worsening of pulmonary oedema
3. Fighting or buckling the ventilator (Asynchronous breathing)
 - inadequate ventilatory support, leak in the ventilatory circuit,
 - inadequate FLO₂ (check the adjustments in the ventilatory system)
4. Barotrauma or volutrauma
 - Subcutaneous emphysema,
 - Pneumopericardium,
 - Pneumoperitoneum,
 - Pneumomediastinum,
 - Pneumothorax,
 - Air-embolism
5. Cardiac arrhythmias
6. Aspiration
7. Pneumonia (nosocomial—>72 hr intubation)
8. Upper GI bleed (gastritis or ulcer)



9. Positive fluid balance and hyponatraemia
10. Oxygen toxicity
11. Tracheal stenosis
12. Hypotension or organ hypoperfusion
13. Mild to moderate cholestasis
14. Acid-base complications (Metabolic/respiratory alkalosis).

Guidelines for Withdrawal of Mechanical Ventilation

1. Mental status of the patient—Awake, alert and cooperative
2. PaO₂ more than 60 mm Hg with FiO₂ less than 50%
3. PEEP < 5 cm H₂O
4. Acceptable PaCO₂ and pH
5. Tidal volume > 5 ml/Kg
6. Vital capacity > 10 ml/Kg
7. Respiratory rate < 30/minute
8. Stable vital signs after 1-2 hours spontaneous breathing trial.

Pulmonary Hypertension

Normal pulmonary artery pressures are as follows:

- Systolic pressure 15–25 mm Hg
- Diastolic pressure 5–10 mm Hg
- Mean pressure 10–15 mm Hg

Pulmonary hypertension is present when pulmonary artery systolic pressure is > 30 mm Hg, and pulmonary artery mean pressure is > 20 mm Hg.

Clinical Classification of Pulmonary Hypertension (Venice 2003)

1. Pulmonary arterial hypertension (PAH)
 - a. Idiopathic pulmonary arterial hypertension (IPAH)
 - b. Familial pulmonary arterial hypertension (FPAH)
 - c. Associated pulmonary arterial hypertension (APAH)
 - i. Collagen vascular disease
 - ii. Congenital systemic to pulmonary shunts
 - iii. Portal hypertension
 - iv. HIV infections
 - v. Drugs and toxins
 - vi. Others—(glycogen storage disorders, haemoglobinopathies, myeloproliferative disorders, splenectomy)
 - d. Associated with significant venous or capillary involvement
 - i. Pulmonary veno-occlusive disease
 - ii. Pulmonary capillary haemangiomatosis

2. Pulmonary venous hypertension
 - i. Left- sided atrial or ventricular heart disease
 - ii. Left- sided valvular heart disease
3. Pulmonary hypertension associated with parenchymal lung disease or chronic hypoxaemia
 - a. COPD (Chronic obstructive pulmonary disease)
 - b. ILD (Interstitial lung disease)
 - c. Sleep disordered breathing
 - d. Alveolar hypoventilation disorders
 - e. Chronic exposure to high-altitude
4. Pulmonary hypertension due to thrombotic or thromboembolic disease
 - a. Thromboembolic obstruction of proximal pulmonary arteries
 - b. Thromboembolic obstruction of distal pulmonary arteries
 - c. Pulmonary embolism (tumour, parasites, foreign material)
5. Pulmonary hypertension due to miscellaneous conditions
 - a. Sarcoidosis
 - b. Pulmonary langerhans cell histiocytosis
 - c. Lymphangiomatosis
6. Compression of pulmonary vessels (tumour, adenopathy, fibrosing mediastinitis).



Clinical Features

Cough, chest pain, haemoptysis, loud P₂, TR murmur, RVH and features of RV failure later.

Functional Assessment of Pulmonary Hypertension

Class I	No limitation of physical activity—No fatigue, dyspnoea, chest pain or syncope for ordinary physical activity
Class II	Comfortable at rest but symptomatic on ordinary physical activity
Class III	Marked limitation of physical activity—less than ordinary physical activity causes chest pain, undue dyspnoea, fatigue or near syncope
Class IV	Unable to carry out any physical activity—Dyspnoeic even at rest with signs of right heart failure

Six-minute walk test: It demonstrates oxyhaemoglobin desaturation on exertion. The distance achieved is lower than expected and it assists in quantifying functional limitations



Investigations

1. *Chest X-ray:* In severe pulmonary hypertension, enlargement of RV and pulmonary arteries are seen.



It may also show evidence of primary lung or cardiac diseases.

2. *Ventilation-perfusion lung scan*: This shows several segmental or greater-sized perfusion defects in thromboembolism. In contrast, in PPH, perfusion scan is either normal or patchy.
3. *Pulmonary angiogram*: It is indicated when there is suspicion of thromboembolism.
4. ECG – Right ventricular and atrial enlargement, RBBB, RV strain pattern.
5. Transthoracic echocardiogram to assess the cardiac status.
6. Pulmonary function testing to assess COPD/restrictive disorders.
7. Arterial blood gas (ABG) – Low PaO₂ and elevated PaCO₂ in case of parenchymal lung disease.
8. Six minute walk test – Un-explained exercise induced de-saturation suggests PH.
9. Nocturnal oximetry – Nocturnal de-saturation in case of sleep-breathing disorder.
10. Transoesophageal echocardiogram – To identify intra-cardiac shunts.
11. CT chest – To assess parenchymal and mediastinal lesions.
12. MRI – To detect cardiac anomalies.
13. Radionuclide ventriculography assesses RV and LV function.
14. Right heart catheterisation – To confirm PAH and plan further management.
15. Lung biopsy – Histologic confirmation of pulmonary vasculitis, veno-occlusive disease and interstitial lung disease.



Management

1. Treat the underlying cause
2. Correct hypoxaemia with oxygen
3. Diuretics in RV failure
4. Vasodilators in PPH
 - a. Calcium channel blockers
 - b. Angiotensin-converting enzyme inhibitors
 - c. Epoprostenol and Treprestinil are the drugs approved for the treatment of pulmonary hypertension.
 - d. Bosentan-endothelin receptor antagonist and sildenafil – an oral phosphodiesterase -5 inhibitor are also used in the treatment of pulmonary hypertension.

Caution: Sudden discontinuation of vasodilator/prostacyclin during chronic use can result in rebound

PH and death. Calcium channel blockers should be used only in vasodilator-responsive patients and not in nonresponders as it might cause hypotension, RVF and death.

Drugs for the Management of Pulmonary Hypertension

No	Name of the drug	Dosage schedule
1.	Nifedipine	20-60 mg tid (Maximum 240 mg/day)
2.	Diltiazem	90-120 mg tid (Maximum 720 mg/day)
3.	Bosentan	62.5-125 mg PO bid (Initiate 62.5 mg)
4.	Sildenafil	20 mg PO tid (caution – Hypotension)
5.	Epoprostenol	2-50 ng/kg/min – IV infusion
6.	Treprestinil	10-50 ng/kg/min – SC or IV infusion
7.	Iloprost	2.5-5 mcg 2-3 hourly inhalation
8.	Dobutamine, milrinone, digoxin	Inotropic agents as required
9.	Anticoagulants– Warfarin	Aim – INR 1.5-2.5
10.	Diuretics	Frusemide and spironolactone

5. Prostacyclin (improves pulmonary haemodynamics, exercise tolerance and survival in PPH when given for more than 12 weeks)
6. Acute inhalation of nitric oxide (in PPH)
7. Creation of a small ASD by balloon septostomy (allows deoxygenated blood to reach LV improving cardiac output)

Atrial septostomy: It allows decompression of the right heart by creating a hole in the septum when the right heart pressure is greater than the left (right-to-left shunt). It is a palliative procedure and it improves left ventricular filling and cardiac output. This procedure is indicated in severe PPH refractory to maximal medical therapy and this serves as a bridge till the transplantation.
8. Heart-lung transplant
9. Surgical intervention in thromboembolism.

Cor Pulmonale

Cor pulmonale is enlargement of the right ventricle with or without failure, secondary to diseases of the lung, thorax, or pulmonary circulation.



Clinical Features

Features of RV failure and evidence of primary lung diseases.



Investigations

1. *Chest X-ray*: prominent RA, RV and pulmonary artery.
2. *ECG*: P pulmonale, right axis deviation, RVH with strain pattern.
3. *Blood count*: Secondary polycythaemia.



Management

1. Treat the primary lung disorder
2. Diuretics
3. Vasodilators
4. Bronchodilators
5. Control of infection.

Pulmonary Thromboembolism

Pulmonary thromboembolism is due to detached thrombi from deep veins of leg (80%); of pelvic veins (10%); or other veins and right sided cardiac chambers (5%) and very rare causes air, fat, tumour cells, placental bits, amniotic fluid, and parasites—schistosomes (5%). Ninety percent of deaths occur within the first hour even before a diagnostic therapeutic plan is implemented.

Risk Factors for Deep Vein Thrombosis

1. Deficiency of antithrombin III, Protein C, and Protein S.
2. Presence of lupus anticoagulant
3. Homocystinuria
4. Surgical procedures of more than 30 minutes duration.
5. Prolonged bed rest following medical illness or surgery or fractures involving lower limbs
6. Chronic deep venous insufficiency
7. Malignancy predisposes to DVT
8. Obesity
9. Oral contraceptives
10. Oestrogen therapy
11. Congestive heart failure
12. Chronic lung disease
13. Hypertension
14. Diabetes mellitus
15. Inflammatory bowel disorders
16. Varicose veins
17. Pregnancy/Postpartum
18. Long distance air travel
19. Cerebro-vascular disorder

20. Indwelling central venous catheters
21. Cigarette smoking
22. Paroxysmal nocturnal haemoglobinuria

- Deep vein thrombosis usually develops in the region of a venous valve.
- Large extensive thrombi can develop within a few minutes.
- Larger leg veins (popliteal and above) are the common source of pulmonary emboli.
- Pulmonary emboli are uncommon in DVT that remains confined to calf veins. Pulmonary embolism is common in the first week of thrombus formation before its fibrinolysis/organisation.
- Pain, warmth, and swelling of legs denote deep vein thrombosis.



Investigations

- Venography is the gold-standard technique for diagnosing DVT. However, non-invasive tests are preferred in symptomatic patients with suspected DVT. It is also contraindicated in renal dysfunction and dye allergy.
- CT venography—It allows visualisation of veins in the abdomen, pelvis and proximal lower extremities.
- MRI venography—It is non-invasive and sensitivity is good for the diagnosis of acute symptomatic proximal DVT. Contraindications for MRI include gadolinium allergy, severe claustrophobia. Certain implanted devices and cerebral aneurysm.
- *PE specific testing*:
 1. Contrast enhanced spiral chest CT
 2. Multidetector CT
 3. V/Q scanning—It needs administration of radioactive material (both inhaled and IV routes)
 4. MR angiography
 5. Pulmonary angiography—gold-standard for diagnosing PE.



Clinical Features

The classical manifestations of pulmonary thromboembolism are unexplained dyspnoea, tachycardia, central chest pain or pleurisy, haemoptysis developing in the second week of postoperative period, especially in patients with a predisposing condition like DVT.

The clinical signs and the results of investigations vary depending on the size of pulmonary vessels involved—large (massive), medium (segmental), or pulmonary microvasculature.



Manifestations of Pulmonary Thromboembolism

	<i>Size of vessels</i>		
	<i>Large (massive)</i>	<i>Medium (segmental)</i>	<i>Microvasculature</i>
<i>Pathology</i>	Reduced cardiac output, sudden loss of cerebral and coronary blood flow, acute right heart failure, altered ventilation perfusion ratio	Pulmonary infarction with or without pleural effusion	Pulmonary hypertension Failure of right heart
<i>Symptoms</i>	Sudden dyspnoea, tachycardia central chest pain sudden syncope	Pleurisy pain Breathlessness Haemoptysis	Dyspnoea and syncope only on exertion
<i>Signs</i>			
CVS	Shock, raised JVP, tachycardia, hypotension, loud/widely split P2 gallop rhythm	Asymptotic or mild tachycardia mild dyspnoea	Asymptomatic late-loud P2 signs of RV failure
RS	Central cyanosis	Pleural rub, crackles haemorrhagic-pleural effusion	Nil
Urine output	Reduced	Normal	Normal
Fever	————	Low-grade fever	————
<i>Investigations</i>			
Chest X-ray	Hilar prominence oligaemic lung fields	Raised hemidiaphragm Wedge-shaped or linear opacities Pleural effusion	Prominent Pulmonary trunk And RV Increased TCD
ECG	(S _I Q _{III} T _{III}) S in lead I Q in lead III Inverted T in lead III and chest leads VI to V4 Right axis deviation, AF Right bundle-branch block	————	Right ventricular hypertrophy and strain
Blood gases	Reduced PaO ₂ Reduced PaCO ₂	Reduced PaCO ₂	Reduced PaO ₂ on exertion
Ventilation perfusion (V/Q lung scans)	Larger areas of defective perfusion	Segmental areas	————
CT with contrast MRI, spiral CT	Diagnostic	Diagnostic	————
Pulmonary angiography	Diagnostic	Diagnostic	————
Lung biopsy	Not required	Not required	Confirms diagnosis



Management

1. Administer oxygen (up to 100%)
2. Morphine 10 mg IV if patient is distressed
3. Heparin – 10,000 to 20,000 units IV bolus
4. Follow it with heparin standard regimens 4 hours later

Standard heparin regimens:

- A. Continuous intravenous—1000 units/hour
- B. Intermittent intravenous—5000 units 4th hourly or 7,500 units qid.
- C. Intermittent subcutaneous—5000 units 4th hourly or 10,000 units tid.

Avoid intramuscular injection of heparin as it causes haematoma. Intramuscular injections must be avoided during heparin therapy. Subcutaneous low molecular weight heparin is equally effective except for the high cost. Heparin therapy is given for 10 days.

5. Thrombolytic therapy with streptokinase or urokinase may be useful in large vein DVT or massive embolism.
6. Pulmonary embolectomy—Rarely indicated



7. Venous interruption—Transvenous placement of filter in the inferior vena cava to protect against emboli greater than 2 mm in diameter.
8. Oral anticoagulants like warfarin to be given for a period of three months after heparin therapy.



Management of DVT

Use one of the standard heparin regimens or low molecular weight heparin for 10 days. No bolus dose of heparin is required. Follow heparin therapy with oral anticoagulants for 3 months.

Lung Transplantation

Indications

End-stage lung disease

- COPD
- Idiopathic pulmonary fibrosis
- Cystic fibrosis
- Primary pulmonary hypertension
- Alpha-1 antitrypsin deficiency (emphysema)
- Eisenmenger's syndrome.

Types

1. Single lung transplantation (right or left) through a thoracotomy
2. Sequential single lung transplantation (through anterior thoracosternotomy)
3. Heart-lung transplantation (through median sternotomy).

Single lung transplantation is performed for non infectious lung disorders and for Eisenmenger's syndrome (where heart defect is correctable at the time of transplant). There is a definite functional improvement. The lack of available donors to meet the demand makes single lung Tx popular.

Disease	Parameters for Tx	Improvement after Tx
Primary pulmonary hypertension	PHT, RV failure, Class III functional status, No response to vasodilators	Pulmonary artery and right heart pressures normalise
Eisenmenger's syndrome	Near syncope, Chest pressure, Haemoptysis	Lung function tests become normal Functional improvement to class I or II
Cystic fibrosis	FEV ₁ < 20% Haemoptysis, Weight loss, frequent infections	Lung function tests normalise
Emphysema	FEV ₁ of 500 cc or less	40–60% after Tx
Interstitial lung disease	Low D _L CO, PHT and RVF, Hypoxaemia during exercise	TLC becomes 70–80%



Complications

Early post-Tx period: Bleeding, bronchial dehiscence or stenosis, reimplantation pulmonary oedema, acute rejection, infection.

Late complications: Infections, renal insufficiency (cyclosporin), obliterative bronchiolitis (warrants sequential bronchoscopy and transbronchial biopsy).

Prognosis

Single lung Tx: 1 year—73%, 2 years—65%, 3 years—62%.

Bilateral, sequential single lung Tx: 1 yr—70%, 2 yr—60%, 3 yr—55% (cystic fibrosis).

Heart lung Tx (Eisenmenger's syndrome): 1 yr—60%, 5 yrs—40%.

Chapter 5

Abdomen



THE HISTORY

ANOREXIA

ALTERED TASTE

SALIVATION
(dry/excess)

DYSPHAGIA

HEART BURN

VOMITING

ABDOMINAL PAIN

ABDOMINAL DISTENSION

HAEMATEMESIS

MELAENA

RECTAL BLEEDING

WEIGHT LOSS

FLATULENCE

HICCUPS

CONSTIPATION

DIARRHOEA

CLAY COLOURED STOOLS

BLOOD/MUCUS IN THE STOOLS

HIGH COLOURED URINE

THE PHYSICAL EXAMINATION

Jaundice

Scratch Marks

Signs of Liver Failure

Signs of Malnutrition

Abdominal Shape

Umbilicus

Abdominal Movement

Consistency

Distension

Distended Veins

Splenomegaly

Divarication of Recti

Other Mass Lesions

Ascites

Hernial Orifices

Rectal/Vaginal/Genital Examination

Bowel Sounds

Arterial Bruits

Venous Hum

Splenic Rub

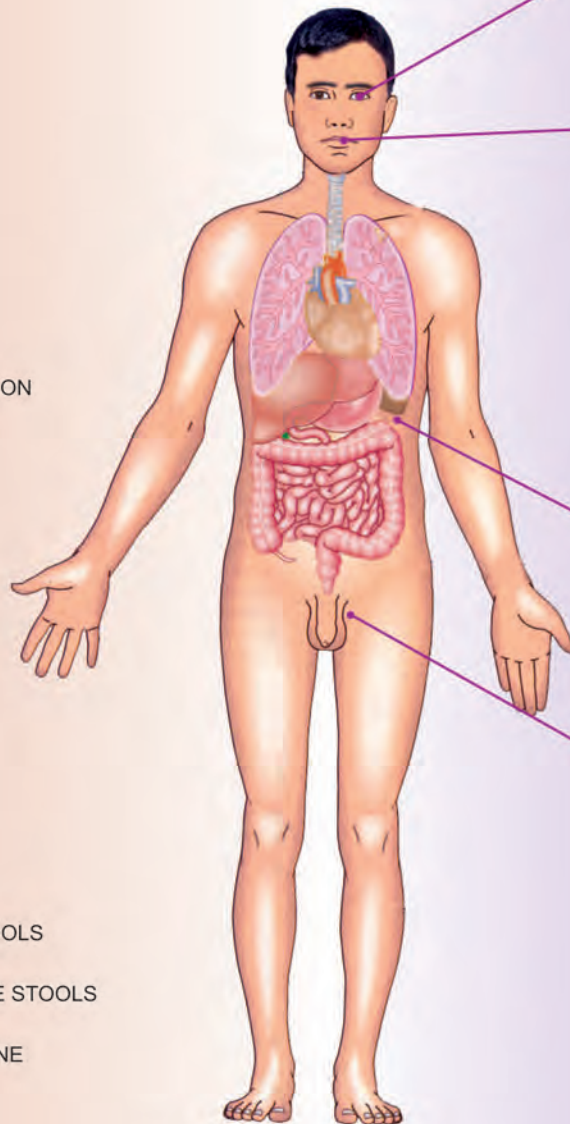



Clinical Examination

Signs and Symptoms

Dysphagia	Difficulty in swallowing		
Aphagia	Inability to swallow		
Odynophagia	Painful swallowing		
Globus pharyngeus	Sensation of a lump lodged in the throat		
Phagophobia	Fear of swallowing		
Anorexia	Loss of appetite or lack of desire to eat	Pseudo-diarrhoea or hyperdefaecation	Normal bowel frequency ranges from 3 times a week to 3 times a day depending on fibre content, medications, exercise and stress Increased frequency of defaecation without increase in stool weight above normal. It is seen in irritable bowel syndrome, hyperthyroidism (increased sympathetic activity) and proctitis
Sitophobia	Fear of eating because of subsequent abdominal discomfort seen in regional enteritis and in chronic mesenteric vascular insufficiency (abdominal angina)	Faecal incontinence	Involuntary release of rectal contents. It is more common when stool is liquid than solid. It reflects weakness of pelvic muscles resulting in abnormal function of anorectal sphincter
Nausea	Feeling of imminent desire to vomit, usually referred to the throat or epigastrium	Acute diarrhoea	Diarrhoea lasts for 1-2 weeks
Vomiting (emesis)	Refers to the forceful oral expulsion of gastric contents	Persistent diarrhoea	Diarrhoea lasts for 2-4 weeks
Retching	Denotes laboured rhythmic contraction of respiratory and abdominal musculatures that frequently precedes or accompanies vomiting	Chronic diarrhoea	Diarrhoea lasts for more than 4 weeks
Hiccough or hiccup or singultus	A phenomenon resulting from sudden spasmodic, involuntary contraction of diaphragm with the glottis remaining closed with the production of short, sharp, inspiratory sounds	Constipation	Frequency of defaecation less than 3 times a week or the stool is hard or difficult to pass
Regurgitation	Appearance of previously swallowed food in the mouth without vomiting, e.g. achalasia cardia	Haematemesis	Vomiting of blood
Water brash	Sudden filling of mouth with saliva produced as a reflex response to a variety of symptoms from upper GIT	Pseudohaematemesis	In patients with upper respiratory bleed, the blood may be swallowed and later vomited as altered blood mimicking an upper GI bleed
Heart burn or pyrosis	Sensation of warmth or burning located substernally or high in the epigastrium with radiation into the neck and occasionally to the arms	Melaena	Passage of stools rendered tarry and black by the presence of altered blood. About 60 ml of blood is necessary to cause melaena. After a single bout of bleeding, melaena persists for about 1 week. Blood must remain in the gut for about 8 hours to produce melaena
Belching	Chronic repetitive eructations	Maroon coloured stool	Passage of maroon coloured stool occurs when the bleeding site is located in the distal small bowel or right colon
Aerophagia	Air swallowing	Haematochezia	Passage of frank blood per rectum. It signifies bleeding from a source distal to ligament of Treitz, especially when bleed occurs from anorectum or left colon. Brisk upper GI bleed with rapid intestinal transit may also result in bright red blood per rectum
Diarrhoea	An increase in daily stool weight more than 200 gm. Typically the patient may also describe an increase in stool liquidity and frequency of more than 3 bowel movements per day. If consistency is liquid or semi-formed even one episode is considered as diarrhoea.	Jaundice	Yellowish discolouration of skin, sclera and mucous membranes resulting from an increase in serum



	<p>bilirubin concentration more than 3 mg/dl.</p> <p>Latent jaundice—serum bilirubin between 1 and 2 mg/dl</p>		
Azotaemia	An increase in serum concentration of urea and creatinine	Nocturia	<p>diuretic phase of ATN, diuretic therapy, hypercalcaemia, hypokalaemia, psychogenic polydipsia (\uparrow thirst), chlorpromazine and anticholinergic agents (\uparrow thirst)</p> <p>Nocturnal urine volume equals or exceeds diurnal urine volume. It is a common symptom of diabetes mellitus, diabetes insipidus, early stages of chronic renal failure, cardiac failure (with treatment), insomnia, prostatic obstruction and other causes of polyuria</p>
Oliguria	This refers to a urine output insufficient to sustain life, usually < 400 ml/day in an adult of average size		
Anuria	This refers to absence of urine flow (< 50 ml/day) and is caused usually by urinary obstruction, total renal arterial or venous occlusion or renal cortical necrosis or RPGN	Dysuria	Refers to pain or burning sensation during urination
Proteinuria	Normal adults may excrete up to 150 mg/day of protein. Of this only 5-15 mg is albumin; the rest is composed of 30 different plasma proteins and of glycoproteins from renal cells, e.g. Tamm-Horsfall mucoprotein	Urinary frequency	Voiding at frequent intervals due to a sense of bladder fullness that is not due to a full bladder but due to an irritable bladder that feels full even when it is not.
Pathologic proteinuria	Excretion of more than 150 mg/day		It is a sign of lower UTI, prostatitis or prostatic enlargement
Mild proteinuria	< 1 gm/24 hr	Urgency	An exaggerated sensation to urinate due to an irritable or inflamed bladder
Moderate proteinuria	1-3.5 gm/24 hr		
Massive proteinuria	> 3.5 gm/24 hr	Incontinence	Inability to retain urine in the bladder
Micro-albuminuria	<p>Normal albumin excretion is 5-15 mg/day.</p> <p>Early morning urine albumin/creatinine ratio > 3, albumin excretion rate (AER) of 20-200 μg per minute or 30-300 mg/24 hours suggest micro-albuminuria; Excretion of mainly albumin signifies a glomerular lesion (selective proteinuria).</p> <p>Milder albuminuria is called asymptomatic urinary abnormality</p>	Enuresis	Involuntary passage of urine at night or during sleep. Enuresis is normal in children < 2 years since the control of urination is only by sacral spinal reflex arc and immaturity of cortical centre.
Orthostatic proteinuria	<p>Finding of protein in urine collected during the day, but not in the first urine passed after rising in the morning. Proteinuria is < 1 gm/24 hours. It is seen in 2-5% in adolescents and rare above 30 yr of age. This condition is usually of no clinical importance</p>	Pyuria	<p>When enuresis occurs or persists beyond 3 years, rule out UTI, obstructive lesions of urinary tract with overflow incontinence, neurovesical dysfunction and other polyuric conditions.</p> <p>Pyuria means presence of pus cells in urine. More than 10 leucocytes/mm^3 of uncentrifuged midstream urine is abnormal in adult women.</p>
Polyuria	<p>Urine volume above 3 L/day, with the recognition that normal individuals who drink a large amount of fluid intake, form large volumes of urine</p> <p><i>Causes:</i> Diabetes insipidus, diabetes mellitus, salt losing nephritis,</p>		<p>Pus cells between 3 and 10 is of doubtful significance. More than 3 leucocytes/mm^3 is abnormal in men.</p> <p>The difference between men and women is as a result of contamination of the urine by vaginal secretions.</p> <p>In centrifuged midstream urine, pus cells more than 5/HPF, is suggestive of pyuria, irrespective of sex.</p>



Sterile pyuria	Pyuria + sterile culture. It is seen in treated UTI, glucocorticoid therapy, pregnancy, transplant rejection, cyclophosphamide therapy, acute febrile episodes, prostatitis, genitourinary trauma. In persistent sterile pyuria, rule out infections due to <i>M. tuberculosis</i> , atypical mycobacteria, anaerobes, <i>H. influenzae</i> .
Haematuria	Haematuria means presence of RBCs in urine. If RBCs are more than 3/cmm in uncentrifuged urine, it is pathological.
Isolated haematuria	Bleeding in the urinary tract from urethra to renal pelvis produces isolated haematuria without significant proteinuria, cells or casts <i>Causes:</i> Stones and neoplasms of urinary tract, renal tuberculosis, trauma, prostatitis
Nephronal haematuria	Blood entering tubular fluid is trapped in a cylindrical mould of gelled Tamm-Horsfall protein to produce RBC casts (degenerated RBCs + clumps of Hb). This always connotes significant renal disease, e.g. glomerulonephritis, tubulointerstitial injury, vasculitis. In general, conditions in which proteinuria and haematuria are occurring together has a bad prognosis than those in which either occurs alone.
Haemoglobinuria	Haemoglobinuria means presence of free haemoglobin in urine. It occurs following intravascular haemolysis or strenuous exercise (normal).
Pneumaturia	Patients have a sensation of passing air bubbles in the urine. It is usually caused by a vesicocolic fistula. It is also common in emphysematous pyelonephritis, especially in diabetics, which is caused by gas producing organisms.

General Examination

Look for

- a. Nutritional status
- b. Anaemia
- c. *Finger clubbing:* A clue to malabsorption, chronic liver impairment, inflammatory bowel diseases, hepatoma



Fig. 5.1: Troisier's sign

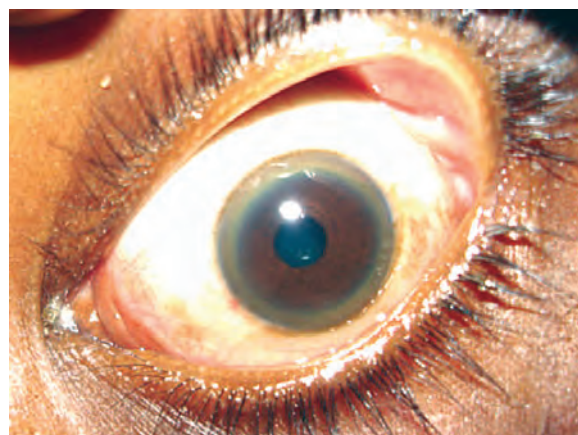

Fig. 5.2: Kayser-Fleischer ring

- d. Leukonychia (occurs in hypoalbuminaemia)
- e. Koilonychia is suggestive of chronic iron deficiency
- f. *Lymphadenopathy:* In leukaemia or lymphoma there may be generalised lymphadenopathy
Virchow's node: Left supraclavicular node may be palpable in GIT malignancy and in pelvic malignancy (*Troisier's sign*) (Fig. 5.1)
- g. Scratch marks of pruritus (obstructive jaundice, obstructive phase of viral hepatitis, uraemia, lymphoreticular disorders)
- h. Kayser-Fleischer ring (Wilson's disease) (Fig. 5.2)
- i. Tylosis of palms in carcinoma of oesophagus.

Signs of Liver Cell Failure

- a. Alopecia
- b. *Foetor hepaticus:* Sweetish, slightly faecal smell of breath similar to freshly opened corpse of mice due



to methyl mercaptan derived from methionine, occurring in hepatocellular failure.

- c. Jaundice
- d. Parotid swelling
- e. Gynaecomastia, testicular atrophy, loss of secondary sexual characters
- f. *Spider naevi*: Central arteriole with radiating vessels resembling legs of spider, seen in SVC territory, due to increased circulating oestrogens. It is seen in 2% of healthy people and in pregnancy. It is also a sign of liver cell failure.

More than five is abnormal and indicate liver cell failure.

Differential Diagnosis:

1. Campbell De Morgan spots (Cherry haemangiomas)

They are bright red, located especially on the front of chest and abdomen. They increase in number and size with the age.

2. Venous star (2-3 cm in diameter)

They occur due to elevation in venous pressure. They are commonly seen over the dorsum of the feet, legs, back and on the lower border of the ribs.

- g. Palmar erythema
- h. Dupuytren's contracture
- i. Asterixis
- j. Xanthelasma.

Look for signs of chronic cholestasis like scratch marks of pruritus and xanthelasma.

Regions of Abdomen (Fig. 5.3)

Abdomen can be arbitrarily divided into 9 regions by drawing two imaginary vertical and horizontal lines as follows. Drop two vertical lines from the mid point of

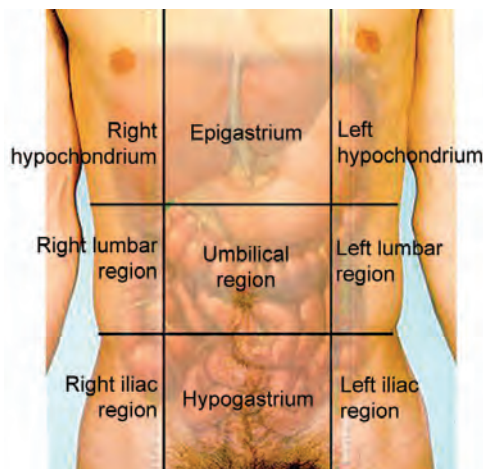

Fig. 5.3: Regions of abdomen



Fig. 5.4: Positioning for abdominal examination

clavicle on either sides. Draw two horizontal lines one at the level of L₁ vertebra (transpyloric plane) and another line at the level of tubercles of the iliac crest.

The regions are:

1. Right hypochondrium
2. Left hypochondrium
3. Epigastrum
4. Right lumbar region
5. Left lumbar region
6. Umbilical region
7. Right iliac fossa
8. Left iliac fossa
9. Hypogastrum.

Inspection (Fig. 5.4)

Shape

1. Generalised fullness or distension due to fat, fluid, flatus, faeces or foetus
2. Localised distension
 - a. Symmetrical and centered around umbilicus—small bowel obstruction
 - b. Asymmetrical—liver or spleen or ovary
3. Scaphoid or sunken abdomen is seen in advanced starvation or malignancy.

Umbilicus

Normal	Slightly retracted and inverted
Everted	In umbilical hernia
Omphalolith	Inspissated desquamated epithelium and other debris
Slit	Vertical (pelvic or ovarian tumours) Horizontal (cirrhosis of liver with ascites).

Movements

Normally there is a gentle rise in abdominal wall in inspiration and a fall during expiration. In peritonitis abdomen is still or silent.

Visible Pulsations

Abdominal aortic pulsations are seen in aortic aneurysm or in thin patients.

Visible Gastric Peristalsis or Visible Intestinal Peristalsis (VGP or VIP)

VGP: This is seen in gastric outlet obstruction. It is a wave of gastric peristalsis seen progressing from the left hypochondrium and epigastric region towards the right lumbar region.

VIP: This is seen in distal small bowel obstruction. It is seen as a step ladder form of peristaltic waves, produced by the hypermotile small intestine, in the umbilical region.

VGP and VIP may however be seen in the absence of obstruction in thin, elderly patients with a lax abdominal wall.

Skin or Surface of Abdomen

- Striae atrophica or gravidarum*: These are white or pink linear marks seen over skin of abdomen produced by gross stretching of the skin with rupture of elastic fibres and it indicates recent change in the size of abdomen.
- Purple striae*: These are seen in Cushing's syndrome.
- Prominent superficial veins*: Distended veins around umbilicus (*caput medusae*) signifies portal hypertension, but it is rarely seen.

In SVC obstruction, the blood flows caudally above the umbilicus. Selecting a segment of vein above the umbilicus to detect the direction of flow is useful to find out SVC obstruction.

IVC Obstruction

There is anastomosis between superficial epigastric and superficial circumflex iliac veins below and lateral thoracic veins above conveying blood from long saphenous vein to axillary vein. Veins are seen in paraspinal region and lateral wall of abdomen. The flow is in the cephalic direction.

Always select a long segment of vein without tributaries below umbilicus for detecting the flow. Flow should be detected in the standing posture only (Fig. 5.5).

Interpretation

- If the flow is away from the umbilicus, in the downward direction, it denotes portal hypertension.
- If the flow is towards the umbilicus, in the cephalic direction, it denotes IVC obstruction.



Fig. 5.5: IVC obstruction



Causes of IVC Obstruction

- Thrombosis of femoral or iliac veins
- Secondary to infection, oral contraceptives, trauma
- Idiopathic retroperitoneal fibrosis
- Hypercoagulable states (nephrotic syndrome)
- Congenital anomalies or tumours of the vein wall
- Embolism
- Compression by massive ascites.



Clinical Features

IVC obstruction can be at three levels (Fig. 5.6)

- Obstruction caudal to renal vein*: Patient presents with oedema of both lower limbs and there is dilatation of superficial veins of leg and abdomen.
- Obstruction at the level of renal vein*: Patient has lumbar pain, renal enlargement, haematuria and proteinuria. Gradual obstruction may lead to collateral formation.
- Obstruction above the renal vein*: Patient has associated obstruction of hepatic veins presenting as acute and chronic Budd-Chiari syndrome.

The clinical features depend on the level, completeness and the rapidity of obstruction.

- Linea nigra* is a pigmentation below umbilicus seen in pregnancy.
- Cullen's sign*: Bluish discolouration of periumbilical region seen in haemorrhagic pancreatitis.

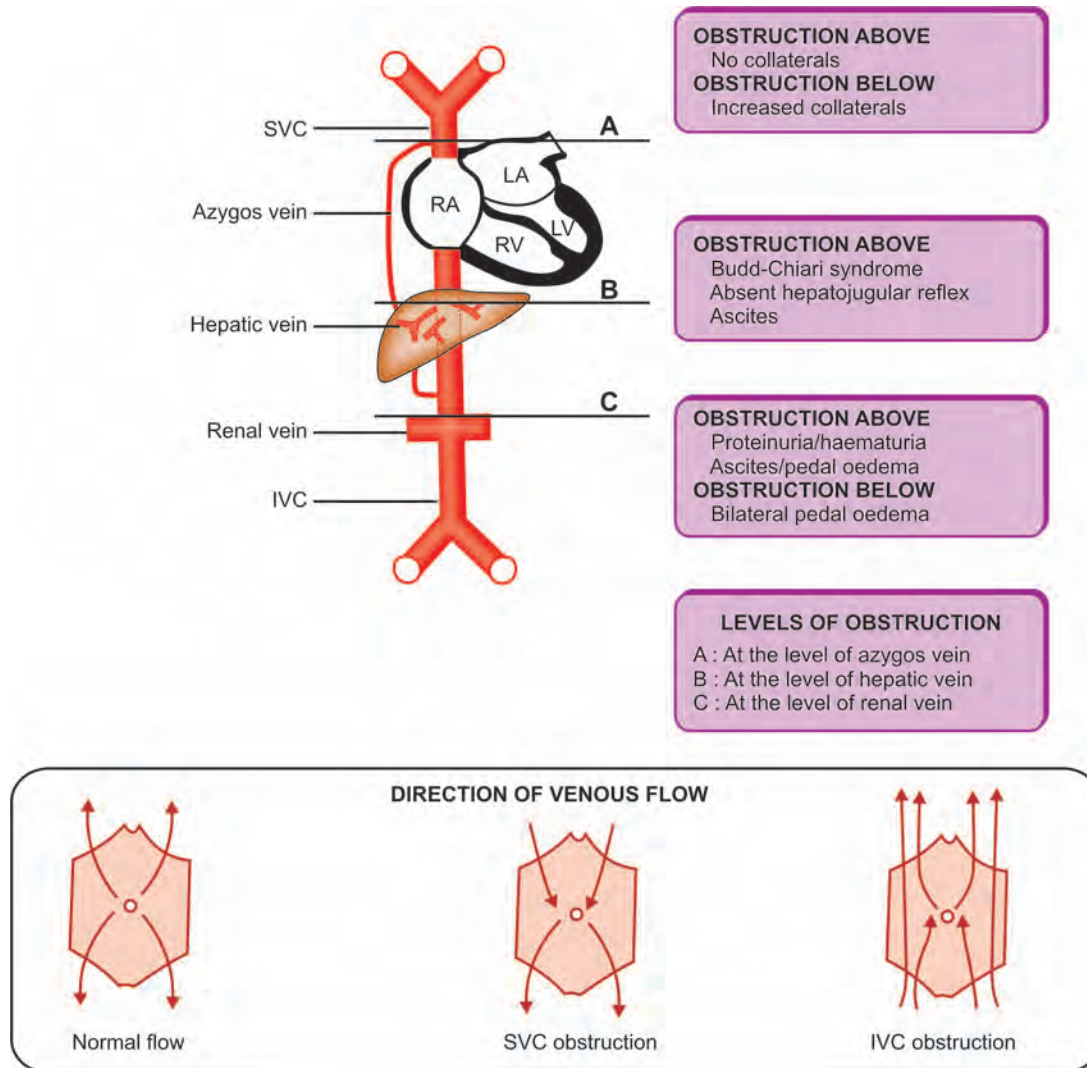

Fig. 5.6: SVC and IVC obstruction

6. *Grey-Turner's sign*: Bluish discolouration of the loins or flanks. This is also seen in haemorrhagic pancreatitis.
7. Examine hernial sites.
3. *Spinoumbilical measurement*: It is the distance between umbilicus and anterior superior iliac spines. Normally they are equidistant. It should be measured on both sides to find out the shift of umbilicus to one side in case of tumours originating from other side of pelvis.

Measurements

1. Abdominal girth should be measured at umbilical level. Periodic measurement is done to assess prognosis in acute abdomen, peritonitis, paralytic ileus and obstruction of bowel.
2. Measure the distance between lower end of xiphisternum to umbilicus and from umbilicus to symphysis pubis. Normally, umbilicus is at mid position. Umbilicus is displaced downwards in cirrhosis with ascites and upwards in ovarian or pelvic tumours.

Surface Marking of Organs

Liver

Upper border of right lobe corresponds to the level of 5th rib, 2.5 cm medial to the right midclavicular line. Upper border of left lobe is at the level of 6th rib in left mid clavicular line.

In men, it corresponds to a line joining a point about 1 cm below the right nipple to a point about 2 cm below the left nipple.

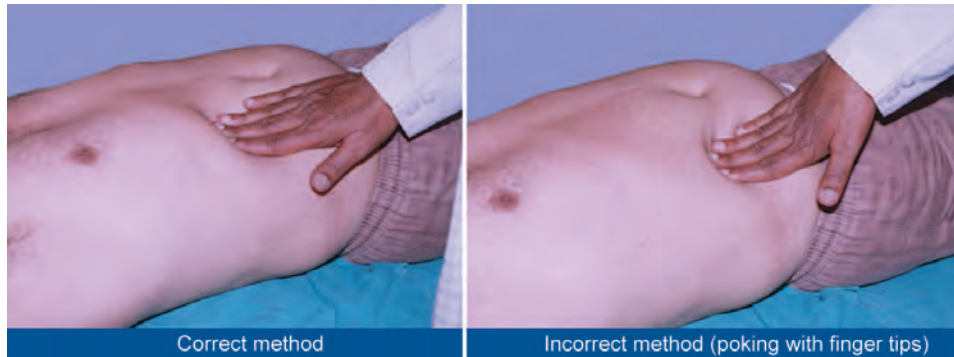

Fig. 5.7: Abdomen palpation

Lower border runs obliquely from 9th right to 8th left costal cartilage crossing the midline about half way between the base of xiphoid cartilage and umbilicus. The left lobe extends to the left of the sternum for about 5 cm.

Spleen

It is situated behind 9th, 10th and 11th ribs with its long axis along the line of 10th rib; anteriorly it extends to mid axillary line while posteriorly its superior angle is 1½" (4 cm) lateral to 10th thoracic spine.

It is separated from 9th, 10th and 11th ribs by the diaphragm.

Kidneys

The surface marking of kidneys is indicated by Morris quadrilateral on either side; Two parallel horizontal lines are drawn on the back at the levels of 11th dorsal and 3rd lumbar spines. They are intercepted by 2 vertical lines drawn 3.75 and 8.75 cm respectively from midline.

Gallbladder

It is situated at the junction of 9th costal cartilage and outer border of right rectus abdominis.

Grey-Turner's Method

Draw a line from left anterior superior iliac spine through umbilicus. At the junction of this and the costal margin, is the gallbladder, provided the shape of abdomen is normal. Gallbladder is better seen than felt when enlarged.

Palpation

Start in left iliac fossa palpating lightly and working anti-clockwise to end in suprapubic region (Fig. 5.7). The order of palpation of organs are:

1. Left kidney
2. Spleen
3. Right kidney
4. Liver
5. Urinary bladder
6. Aorta and para-aortic glands and common iliac vessels
7. Palpate both groins
8. Examine external genitalia.

Light and deep palpation should be followed by palpation during respiration.

Palpation by Dipping

This method is used in tense ascites to detect the presence of hepatic or splenic enlargement. The technique may help to detect and map the outlines of enlarged organs or of tumours. Sudden displacement of liquid gives a tapping sensation over the surface of liver or spleen similar to patellar tap. For eliciting this, place the hand flat on abdomen and make quick dipping movements.

Structures normally palpable are:

1. Aorta
2. Edge of the liver
3. Lower pole of either kidney
4. Hard faeces
5. Rectus abdominis
6. Normal colon
7. Small inguinal lymph nodes
8. Distended bladder.

When an organ is enlarged, assess the following:

- a. Edge or border (sharp or rounded)
- b. Surface (smooth or nodular)
- c. Consistency (soft, firm or hard)
- d. Presence of tenderness
- e. Movement with respiration.



Fig. 5.8: Start from right iliac fossa and go upwards

Palpation of Liver

Place the hand flat on abdomen with fingers pointing upwards and position the sensing fingers (index and middle) lateral to rectus muscle so that finger tips lie on a line parallel to expected liver edge.

Press hand firmly inwards and upwards and keep it steady while patient takes a deep breath through mouth. Wait for one full phase of respiration and continue to workup laterally.

With this method, tip of fingers should slip over the edge of palpable liver (Fig. 5.8).

Second Method

Keep right hand below and parallel to right subcostal margin. The liver edge will then be felt against the radial border of index finger, confirm with percussion. Avoid placing hand over rectus abdominis. Do not begin palpation too close to costal margin.

Soft, smooth, tender liver	Congestive cardiac failure Acute viral hepatitis
Firm and regular	Obstructive jaundice and cirrhosis of liver, chronic congestive cardiac failure (nutmeg liver).
Nodular liver	In advanced secondary carcinoma, hepatoma
Pulsatile liver	Systolic pulsations-tricuspid regurgitation. Diastolic pulsations-tricuspid stenosis

Riedel's lobe (a tongue-like projection of right lobe of liver)

Palpation of Gallbladder

It is felt as a firm, smooth, rough or globular swelling with distinct borders, just lateral to the edge of the rectus abdominis near the tip of ninth costal cartilage. It moves with respiration.

It is palpable in:

1. Carcinoma head of the pancreas
2. Mucocele or impacted gallstone in the neck of a collapsed empty and uninfected gallbladder. Mucus is secreted into the lumen and in later stages gallbladder becomes palpable.
3. *Carcinoma of gallbladder*: Gallbladder is felt as a stony hard, irregular swelling.

Courvoisier's Law

Gallbladder is distended and palpable in carcinoma of pancreas; In cholelithiasis, the gallbladder wall is diseased, thickened, contracted and not palpable due to repeated cholecystitis.

Murphy's Sign

Ask the patient to breathe in deeply and palpate for gallbladder in the normal way. At the height of inspiration, the breath is arrested with a gasp as the mass is felt. This is the sign of acute cholecystitis.

Palpation of Spleen (Fig. 5.9)

- To become palpable, spleen should have enlarged 2-3 times. Direction of enlargement is towards right iliac fossa.
- Palpate from right iliac fossa to left hypochondrium
- Wait for one full phase of respiration
- At the height of inspiration, release the pressure on the examining hand so that the finger tips slip over the lower pole of spleen, confirming its presence and surface characteristics.
- If spleen is not palpable, move the examining hand upwards after each inspiration until the finger tips are under the costal margin.
- Repeat this process along the entire rib margin as the position of the enlarging splenic tip is variable.
- If still not palpable, position the patient in the right lateral position with the left hip and knee flexed.
- Place the other hand posteriorly to support the lower rib cage and repeat the examination.
- Alternatively, examine for spleen from patient's left side, curling the fingers of left hand beneath the costal margin as the patient breathes deeply.
- *Middleton's manoeuvre*: In this method, the examiner stands on the left side of the patient facing the foot of the bed. The hooked fingers of the left hand are placed under the costal margin and with right hand pressure

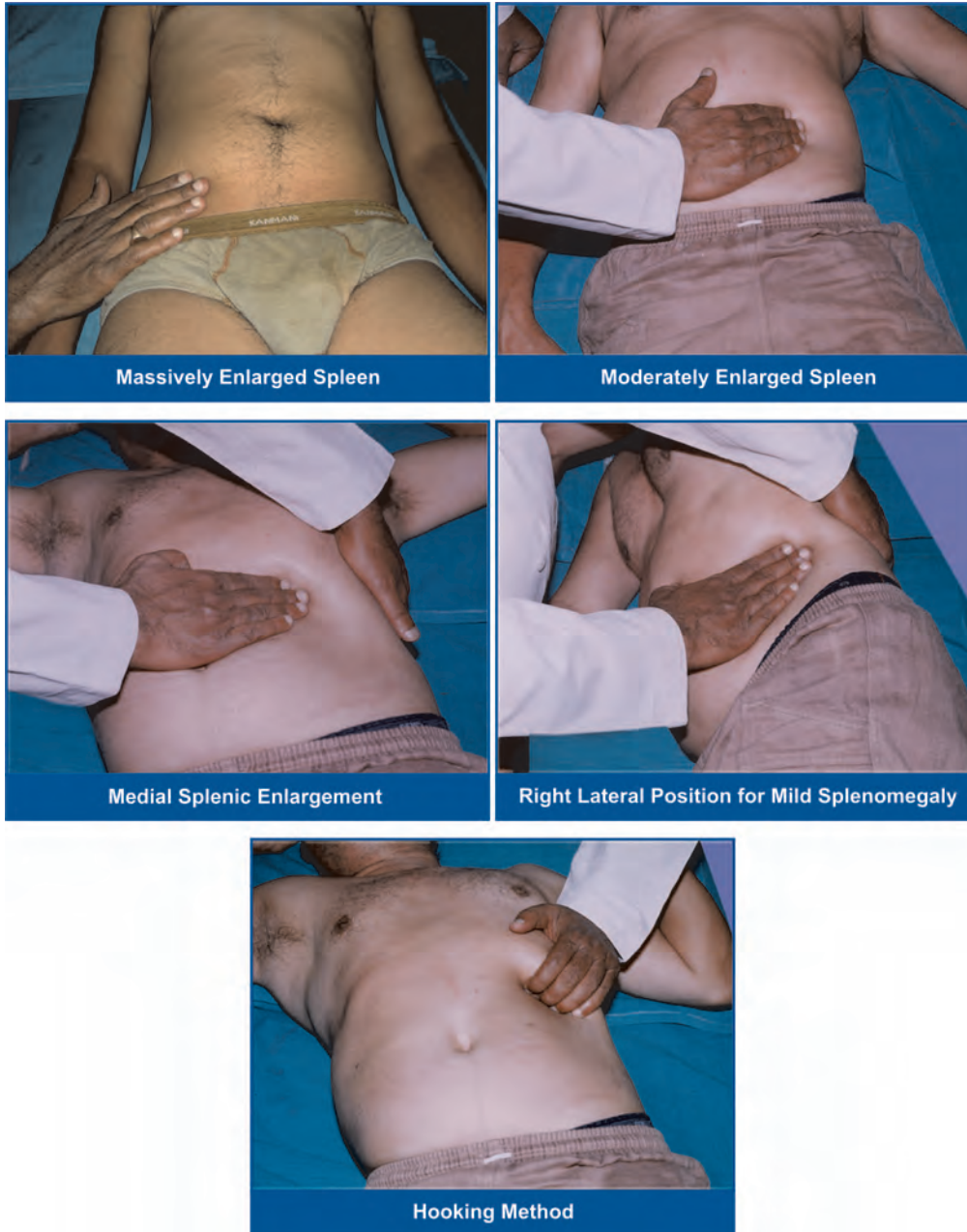

Fig. 5.9: Palpation of spleen—various techniques

is exerted over the postero-lateral aspect of the lower thorax. The patient is then asked to take a deep breath and spleen is felt at the end of deep inspiration.

Palpation of Kidneys (Fig. 5.10)

1. Use bimanual technique to palpate the kidneys.
2. Place one hand posteriorly below lower rib cage and the other over upper quadrant.
3. Push the two hands together firmly, but gently as the patient breathes out.
4. Feel for the lower pole as the patient breathes in deeply.
5. Try to trap the palpable kidney between the two hands by delaying application pressure until the end of inspiration. This helps in palpation, as the kidney slides up on expiration.



Fig. 5.10: Bimanual palpation of kidney

6. Confirm the structure of the kidney, by pushing the kidney between the two hands (ballotting) and by assessing its degree of movement during respiration.
7. Assess the size, surface and consistency of a palpable kidney.
8. Examine the left kidney from either side.

Palpation of Urinary Bladder

Normally it is not palpable. It is palpable as a smooth, firm, regular, oval shaped swelling in suprapubic region and its dome may reach as far as the umbilicus. Its lower

Difference between Left Kidney and Spleen

Features	Left kidney	Spleen
Location	Posterior L ₁ region	Anterior 9th, 10th, 11th ribs
Edge	Rounded edge	Sharp edge
Notch	Absent	Present
Insinuation of fingers between costal margin and the organ	Fingers can be insinuated	Fingers cannot be insinuated
Band of colonic resonance	Present	Absent
Enlargement	Towards lumbar region	Towards right iliac fossa (since the left colic flexure and the phrenico-colic ligament prevent the direct downward enlargement)
Movement with respiration	Restricted	Moves freely on inspiration
Bimanual palpation	Palpable	Not palpable
Ballotability	Ballotable	Not ballotable
Loin fullness and dullness	Present	Absent

Lower pole of the kidneys can at times be palpable in a thin individual. Huge spleen can be bimanually palpable

border cannot be felt. It is symmetrically placed in suprapubic region beneath the umbilicus, which is dull on percussion.



Differential Diagnosis

1. *Gravid uterus*: It is firmer, mobile side to side and vaginal signs are present.
2. *Fibroid uterus*: It is felt as a bosselated, firm swelling with different vaginal signs.
3. *Ovarian cyst*: It is eccentrically placed (left or right side).

Examination of Groins, Para-aortic Nodes and Vessels

- Examine groins for hernia
- Palpate aorta and common iliac vessels
- Para-aortic nodes are palpable when considerably enlarged and they are felt as round, firm, confluent masses in the umbilical region and epigastrium along the left border of aorta.

Tenderness

It is suggestive of disease or inflammation of an underlying organ, provided abdominal wall is normal (Fig. 5.11).

Rebound tenderness: Patients complain of sharp pain when pressure over a painful area is suddenly released. This signifies inflammation of not only the viscera but also of the parietal peritoneum.

Shifting tenderness: It may be present in acute non-specific mesenteric adenitis.

Referred or crossed tenderness: When pressure is applied to one area of abdomen there is pain or tenderness in



Fig. 5.11: Murphy's punch. Method of eliciting loin tenderness (for kidney)



another area. It is seen in acute appendicitis (Rovsing's sign) when pressure applied over descending colon elicits pain or tenderness over right iliac fossa.

Doughy feel of abdomen is diagnostic of tuberculous peritonitis. It may also be present in tropical sprue or in multiparous women.

Percussion

Defining Boundaries

Liver

Upper and lower border of right lobe of liver can be mapped out. Start anteriorly at the 4th inter costal space where the note will be resonant over lungs and work downwards vertically.

In normal liver, upper border is at 5th inter costal space where note is dull; This extends down to the lower border found at or just below right subcostal margin. The normal dullness over the upper part of liver is reduced in:

1. Severe emphysema
2. Large right pneumothorax
3. Gas or air in peritoneal cavity (perforation of a viscus).

Percussion below the right costal margin is useful in hepatomegaly. Ask the patient to breathe in deeply as you percuss, lightly keeping the fingers parallel to the rib margin. As the liver descends during inspiration, a change in note from resonance to dull signifies liver edge.

Liver span: Direct measure of liver size is 12-15 cm in height extending from 5th rib or (below right nipple in men) to the palpable border or right costal margin. Serial measurement is done to find out shrinkage or enlargement. Palpable liver size is expressed as so many cm below the right costal margin at the mid clavicular line.

Spleen

Dullness extends from left lower ribs to the left hypochondrium and left lumbar region. Splenic dullness gives way to the resonance of surrounding bowel.

Newer methods of percussion of spleen

1. *Nixon's method:* The patient is placed on the right side so that the spleen lies above the colon and stomach. Percussion begins at the lower level of pulmonary resonance in the posterior axillary line and proceeds diagonally along a perpendicular line toward the lower mid anterior costal margin. The upper border of dullness is normally 6-8 cm above the costal margin. Dullness greater than 8 cm in an adult is presumed to indicate splenic enlargement.

2. *Castell's method:* With patient supine, percussion in the lowest intercostal space in the anterior axillary (8th or 9th) produces a resonant note if the spleen is normal in size. This is true during expiration or full inspiration. A dull percussion note on full inspiration suggests splenomegaly.

Bladder

Superior and lateral borders can be defined from the adjacent bowel.

Percussion can also be Used for Detecting Fluid in the Abdomen by the Following Methods

Shifting Dullness

With the patient lying supine, percuss laterally from the midline keeping the fingers in the longitudinal axis until dullness is detected (Fig. 5.12).

In normal individuals, flanks are resonant. In patients with moderate ascites, flanks are dull (except in loculated ascites or when there are adherent loops of bowel). On shifting the patient to one side, either to the right or left lateral decubitus position, the previous dull area over the flank becomes resonant. This is due to the shift of fluid in the peritoneal cavity. This shift of fluid can be doubly confirmed by a rise in the level of dullness in the opposite flank (Fig. 5.13).

About 1000 ml of fluid should be present to elicit this sign.

Fluid Thrill

Patients lies on his back. Place one hand over the lumbar region of one side, get an assistant or the patient himself



Fig. 5.12: Percuss from the midline to the sides (resonant to dull area)



Fig. 5.13: The dull note disappears on putting the patient in lateral position due to shift of fluid



Fig. 5.15: Method for eliciting puddle's sign



Fig. 5.14: Flick or tap gently (avoid violent tapping)

to put the side of his hand firmly in the midline of the abdomen and then flick or tap gently the lumbar region (Fig. 5.14). A fluid thrill or wave is felt as a definite and unmistakable impulse by the detecting hand held flat in the opposite lumbar region. The purpose of keeping the assistant's hand is to dampen any impulse that may be transmitted through the fat of the abdominal wall. This is felt when there is a large amount of fluid under tension, i.e. > 2000 ml.

Absence of fluid thrill and shifting dullness or any of them, does not exclude diagnosis of ascites.

Puddle's Sign

This sign is elicited to detect the presence of minimal fluid when flanks are resonant. This can be elicited either by percussion or by auscultopercussion (Figs 5.15 and 5.16).



Fig. 5.16: Eliciting puddle's sign by auscultopercussion method

It can detect as little as 120 ml of ascitic fluid. Patient is to lie in the prone position for 5 minutes and goes on all 4 limbs (arm-knee position) so that the middle portion of abdomen is dependent and his back is horizontal. New percuss around umbilicus and elicit dullness. Previously resonant area becomes dull if minimal fluid is present. Place a stethoscope over umbilical region and scratch the abdominal wall from periphery towards umbilicus. A change in the quality of sound is perceived while crossing the fluid column. This sign is false-positive in massive splenomegaly and distended bladder.

USG Abdomen

It can detect as little as 30 ml of fluid.

Grading of Ascites

- + Detectable only by careful examination.
- ++ Easily detectable but of relatively small volume.



- +++ Obvious ascites but not tense.
- ++++ Tense ascites.

Chronic ascites is associated with

1. Umbilical hernia
2. Puncture marks
3. Striae
4. Divarication of recti.

In ascites, usually flanks are dull and the centre of abdomen is resonant and in ovarian or pelvic tumours, the centre of abdomen is dull and the flanks may be resonant. However, in gross ascites and in large ovarian tumours, both the flanks and the centre of abdomen may be dull on percussion.

Percussion of Cyst (Hydatid Thrill)

Keeping 3 fingers over the cyst, percuss over the middle finger. A thrill is elicited which can be felt by other 2 fingers.

Auscultation

Auscultation of abdomen is done for:

Bowel Sounds

Normal motility of the gut creates a characteristic gurgling sounds every 5-10 seconds which can be heard by unaided ear (Borborygmi).

Bowel sounds are increased in:

- a. Simple, acute, mechanical, small bowel obstruction. Increased bowel sounds with colicky pain is pathognomonic of small bowel obstruction. In between colicky pain, bowel is quiet and no sounds are audible
- b. Malabsorption
- c. Severe GI bleeding
- d. Carcinoid syndrome.

Bowel sounds are absent in

- a. Paralytic ileus
- b. Peritonitis.

In later stages of paralytic ileus, high pitched, tinkling sounds due to fluid spill over from one distended gas and fluid filled loop to the other can be heard.

Succussion Splash

It is a sound resembling shaking a half filled bottle. It is heard in:

1. Pyloric stenosis
2. Advanced intestinal obstruction
3. Paralytic ileus (with grossly distended loops of bowel)
4. Normal stomach within 2 hours after a meal.

Bruit

- Bruit over aorta can be heard above and to the left of umbilicus in cases of aortic aneurysm. Aortic bruit can also be heard over femoral artery.
- Bruit over mid abdomen is heard in renal artery stenosis.
- Bruit over common iliac artery can be heard in stenosis or aneurysm.
- Bruit over liver may be heard in:
 - a. Haemangioma
 - b. Hepatocellular carcinoma
 - c. Acute alcoholic hepatitis
 - d. Hepatic artery aneurysm.
- Bruit can also be heard in coeliac artery stenosis and carcinoma pancreas (due to compression of vessels).

Venous Hum

It is heard between xiphisternum and umbilicus due to turbulence of blood flow in well-developed collaterals as a result of portal hypertension (Cruveilhier-Baumgarten syndrome). It signifies a congenital patent umbilical vein draining into the portal vein.

Friction Rub

It is heard in perisplenitis or perihepatitis due to microinfarction and inflammation.

Splenic rub is heard in the following conditions:

- a. Chronic myeloid leukaemia
- b. Infective endocarditis
- c. Sickle cell anaemia
- d. After biopsy.



Causes of Hepatomegaly

Infective

- | | |
|---------------------------|--|
| a. Along the biliary tree | Cholangitis |
| b. Along portal vein | Amoebiasis
Schistosomiasis
Bacterial infections |
| c. Along hepatic artery | Bacterial
Typhoid, brucellosis
tuberculosis, syphilis,
Weil's disease |
| Viral | Infective hepatitis-infectious mononucleosis |
| Protozoal | Malaria, kala-azar |
| Fungal | Actinomycosis histoplasmosis |
| Parasitic | Echinococcosis (hydatid cyst) |



Congestive

Congestive cardiac failure
 Cardiomyopathy
 Constrictive pericarditis
 Budd-Chiari syndrome.

Degenerative and Infiltrative

Alcoholic fatty liver
 Lymphomas
 Leukaemias
 Multiple myeloma.

Storage Disorders

Niemann-Pick disease
 Gaucher's disease
 Amyloidosis.

Neoplasia

Hepatocellular carcinoma
 Cholangiocarcinoma
 Secondaries.

Toxins

Alcohol, arsenic
 Phosphorous, drugs.



Causes of Painful Hepatomegaly

Congestive cardiac failure
 Viral hepatitis
 Hepatic amoebiasis
 Pyemic abscess
 Hepatoma
 Actinomycosis
 Secondaries
 Budd-Chiari syndrome.



Causes of Pulsatile Liver

Tricuspid regurgitation (systolic)
 Tricuspid stenosis (diastolic)
 Aortic regurgitation.



Causes of Splenomegaly

Mild (up to 5 cm)

Congestive cardiac failure
 Acute malaria

Typhoid
 Infective endocarditis
 Septicaemia
 Systemic lupus erythematosus
 Rheumatoid arthritis
 Thalassaemia minor
 Miliary tuberculosis
 Leptospirosis
 HIV.

Moderate (5-8 cm)

Viral hepatitis
 Cirrhosis
 Lymphomas
 Leukaemias
 Infectious mononucleosis
 Haemolytic anaemias
 Splenic infarcts
 Splenic abscess
 Amyloidosis
 Haemochromatosis
 Polycythaemia.

Massive (> 8 cm)

Chronic myeloid leukaemia
 Myeloid metaplasia
 Myelofibrosis
 Hairy cell leukaemia
 Gaucher's disease
 Niemann-Pick disease
 Sarcoidosis
 Thalassaemia major
 Chronic malaria
 Kala-azar
 Congenital syphilis
 Extrahepatic portal vein obstruction
 Schistosomiasis
 Diffuse splenic haemangiomas
 Lymphoma
 Polycythaemia.



Causes of Hepatosplenomegaly

Infections

Malaria
 Kala-azar
 Infective hepatitis
 Disseminated tuberculosis
 Bacterial endocarditis
 Infectious mononucleosis.

Haematological Disorders

Anaemia (chronic haemolytic anaemia)
 Myeloproliferative disorders
 Chronic myeloid leukaemia
 Myelofibrosis
 Non-Hodgkin's lymphoma
 Hodgkin's lymphoma.

Congestive States

Congestive cardiac failure
 Constrictive pericarditis
 Cirrhosis of liver with portal hypertension
 Budd-Chiari syndrome.

Storage Disorders

Gaucher's disease
 Amyloidosis
 Glycogen storage disorders.



Causes of Hepatosplenomegaly + Lymphadenopathy

Lymphomas
 Lymphocytic leukaemia
 Infectious mononucleosis
 Disseminated tuberculosis
 Sarcoidosis
 HIV
 Disseminated histoplasmosis

Gastrointestinal System

Dysphagia

Dysphagia means difficulty in swallowing.



Causes of Dysphagia

Mechanical Dysphagia

- I. *Luminal*
 - A. Large bolus
 - B. Foreign body
- II. *Intrinsic narrowing*
 - A. *Inflammatory condition causing oedema and swelling*
 - i. Stomatitis
 - ii. Pharyngitis, epiglottitis
 - iii. Oesophagitis
 1. Viral (herpes simplex, varicella-zoster, cytomegalovirus)
 2. Bacterial
 3. Fungal (candidal)
 4. Mucocutaneous bullous diseases
 5. Caustic, chemical, thermal injury
 - B. *Webs and rings*
 1. Pharyngeal (Plummer-Vinson syndrome)
 2. Oesophageal (congenital, inflammatory)
 3. Lower oesophageal mucosal ring (Schatzki ring)
 - C. *Benign strictures* (Fig. 5.17C)
 1. Peptic
 2. Caustic and pill-induced

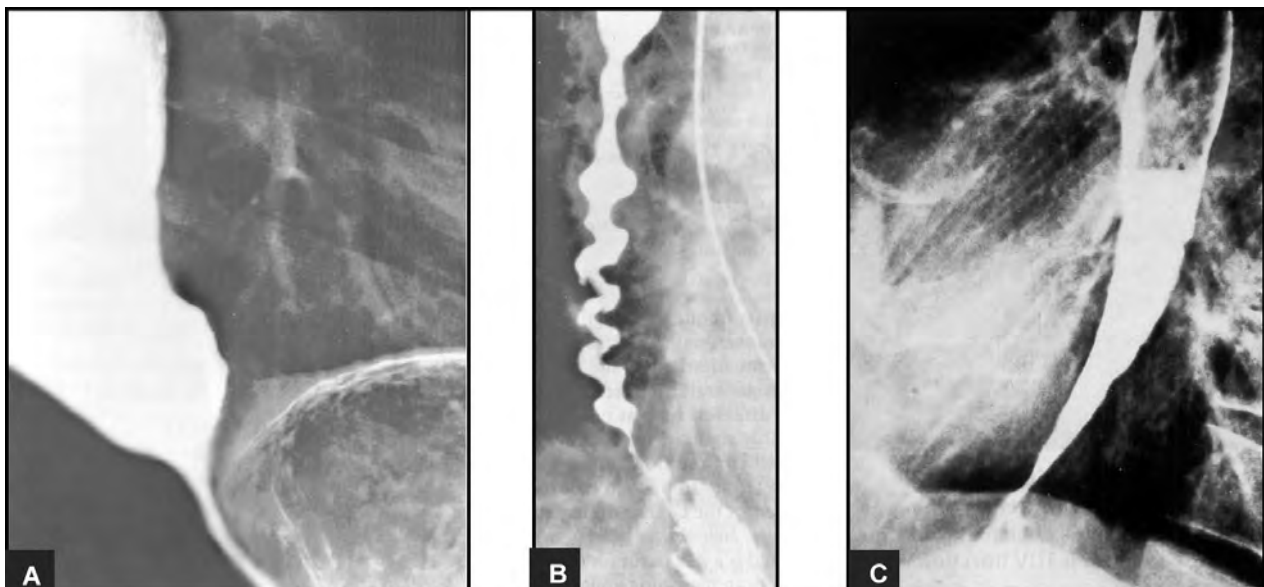

Figs 5.17A to C: (A) Achalasia cardia (B) Oesophageal spasm (C) Oesophageal stricture



3. Inflammatory (Crohn's disease, candidal, mucocutaneous lesions)
 4. Ischaemic
 5. Postoperative, postirradiation
 6. Congenital
- D. *Malignant tumours*
1. Primary carcinoma
 - a. Squamous cell carcinoma
 - b. Adenocarcinoma
 - c. Carcinosarcoma
 - d. Pseudosarcoma
 - e. Lymphoma
 - f. Melanoma
 - g. Kaposi's sarcoma
 2. Metastatic carcinoma
- E. *Benign tumours*
1. Leiomyoma
 2. Lipoma
 3. Angioma
 4. Inflammatory fibroid polyp
 5. Epithelial papilloma
- III. *Extrinsic compression*
- A. Cervical spondylitis
 - B. Vertebral osteophytes
 - C. Retropharyngeal abscess and masses
 - D. Enlarged thyroid gland
 - E. Zenker's diverticulum
 - F. Vascular compression
 - i. Aberrant right subclavian artery
 - ii. Right-sided aorta
 - iii. Left atrial enlargement
 - iv. Aortic aneurysm
 - G. Posterior mediastinal masses
 - H. Pancreatic tumour, pancreatitis
 - I. Postvagotomy haematoma and fibrosis

Motor (Neuromuscular) Dysphagia

- I. *Difficulty in initiating swallowing reflex*
- A. Paralysis of the tongue
 - B. Oropharyngeal anaesthesia
 - C. Lack of saliva (e.g. Sjögren's syndrome)
 - D. Lesions of sensory components of vagus and glossopharyngeal nerves
 - E. Lesions of swallowing centre
- II. *Disorders of pharyngeal and oesophageal striated muscle*
- A. *Muscle weakness*
1. Lower motor neuron lesion (bulbar paralysis)
 - a. Cerebrovascular accident
 - b. Motor neuron disease
 - c. Poliomyelitis, post-polio syndrome
 - d. Polyneuritis

- e. Amyotrophic lateral sclerosis
 - f. Familial dysautonomia
2. Neuromuscular
 - a. *Myasthenia gravis*
 3. *Muscle disorders*
 1. Polymyositis
 2. Dermatomyositis
 3. Myopathies (myotonic dystrophy, oculopharyngeal myopathy)
- B. *Non-peristaltic contractions or impaired deglutitive inhibition*
1. Pharynx and upper oesophagus
 - a. Rabies
 - b. Tetanus
 - c. Extrapyrmidal tract disease
 - d. Upper motor neuron lesions (pseudobulbar paralysis)
 2. Upper oesophageal sphincter (UES)
 1. Paralysis of suprahyoid muscles (causes same as paralysis of pharyngeal musculature)
 2. Cricopharyngeal achalasia
- III. *Disorders of oesophageal smooth muscle*
- A. *Paralysis of oesophageal body causing weak contractions*
1. Scleroderma and related collagen-vascular diseases
 2. Hollow visceral myopathy
 3. Myotonic dystrophy
 4. Metabolic neuromyopathy (amyloid, alcohol?, diabetes)
 5. Achalasia (classical) (Fig. 5.17A)
- B. *Non-peristaltic contractions or impaired deglutitive inhibition*
1. Oesophageal body
 - a. Diffuse oesophageal spasm (Fig. 5.17B)
 - b. Achalasia (vigorous)
 - c. Variants of diffuse oesophageal spasm
 2. Lower oesophageal sphincter
 - A. Achalasia
 1. Primary
 2. Secondary
 - i. Chagas' disease
 - ii. Carcinoma
 - iii. Lymphoma
 - iv. Neuropathic intestinal pseudo-obstruction syndrome
 - v. Toxins and drugs
 - B. Lower oesophageal muscular (contractile) ring.

Diagnostic Approach to Dysphagia

Dysphagia is a serious symptom unless it is associated with a transitory sore throat and hence it has to be investigated thoroughly, especially to exclude neoplasia.

Dysphagia occurring within one second of onset of swallowing suggests oropharyngeal cause.

When swallowing is associated with a gurgling noise or neck bulge, suspect pharyngeal pouch (*Zenker's diverticulum*). If dysphagia is constant and painful, suspect malignant stricture.

When there is difficulty in initiating swallowing, which is associated with cough or choking sensation, suspect an oropharyngeal cause of dysphagia.

If the patient complains of a sensation of stopping or sticking of food bolus, after having initiated swallowing, think of oesophageal cause of dysphagia. This may be relieved by repeated swallowing or raising the arm over the head.

Dysphagia for solid food only, suggests a mechanical obstruction. This, in turn, can be:

- a. Intermittent, e.g. lower oesophageal ring
- b. Progressive, e.g. peptic stricture, carcinoma.

Dysphagia for solid or liquid food suggests a neuromuscular disorder. This, in turn, can be

- a. Intermittent (diffuse oesophageal spasm)
- b. Progressive (scleroderma involving lower 1/3 of oesophagus, achalasia cardia).

Treatment

1. Treat the specific underlying cause.
2. Special care should be given in patients with a neurological disorder, with special attention to dietary texture, body, head and neck position, and size and frequency of food bolus administration.
 - a. The bolus size should be small in sips or bites.
 - b. Thick fluids and pudding texture are better than clear liquids.
 - c. Avoid spices, acidic foods and coffee, tea and alcohol.
 - d. Patient should remain in upright position for at least 1-3 hours after meals (to avoid aspiration).
 - e. The head of the bed should be elevated while resting and sleeping.

Achalasia Cardia

It is a condition in which there is a failure of oesophageal peristalsis along with failure of relaxation of the lower oesophageal sphincter. There is difficulty in swallowing both liquids and solids, which may be progressive, and associated with regurgitation.

Complications

1. Aspiration pneumonia
2. Carcinoma

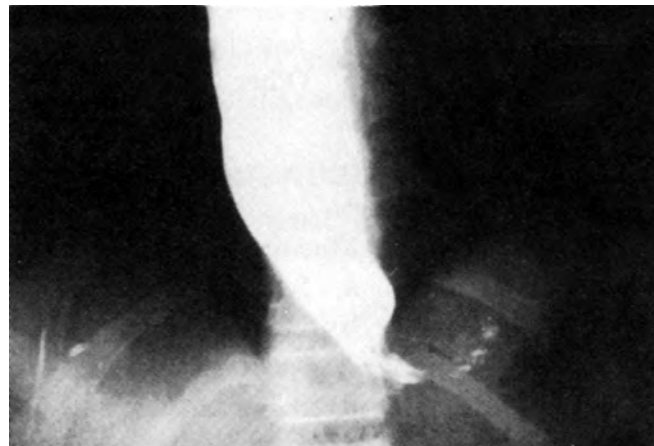

Fig. 5.18: Barium swallow—achalasia cardia

Investigations

Barium Swallow

It shows a highly characteristic appearance of proximal dilatation with distal smooth tapering (Fig. 5.18). In advanced cases oesophagus may become sigmoid.

Plain X-ray Chest

It shows absence of gastric air bubble with retrocardiac air fluid level.

Fluoroscopy

- a. Absence of peristalsis in the lower 2/3 of oesophagus
- b. Terminal part of oesophagus shows persistent beak like narrowing representing non-relaxing lower oesophageal sphincter.

Endoscopy

Upper GI endoscopy to rule out malignancy.

Pseudoachalasia

Malignancy at the gastro-oesophageal junction mimics achalasia cardia.

Manometer

- a. Basal lower oesophageal sphincter pressure is normal or elevated.
- b. Swallowing induced relaxation of lower oesophageal sphincter is reduced or absent.

Treatment

Medical

- a. Pneumatic dilatation



- b. Calcium channel blocker, nitrates and sildenafil.
- c. Botulinum toxin—Endoscopic intrasphincteric injection blocks cholinergic excitatory nerves and thereby relieves symptoms.

Surgical

Heller's myotomy
Laparoscopic myotomy

Gastro-oesophageal Reflux Disease

Burning retrosternal discomfort is the main symptom. The warning symptoms are dysphagia, odynophagia, early satiety, weight loss and bleeding. Atypical symptoms could be cough, asthma, hoarseness, chest pain, aphthous ulcers, hiccups and dental erosions.



Diagnosis

1. Oesophagoscopy
2. Ambulatory pH monitoring



Complications

Ulcerations, stricture, iron deficiency anaemia, Barret's oesophagus



Treatment

1. Lifestyle modification
2. H₂ receptor blockers, PPI
3. Surgery—Nissen's fundoplication if medical management fails.

Peptic Ulcer Disease

This refers to a disorder of the upper gastrointestinal tract caused by the action of acid and pepsin.

Peptic Ulcer

Pathogenesis

The development of peptic ulcer depends on the interplay of the following injurious and protective factors.

Injurious Factors

1. Endogenous
 - a. Acid
 - b. Pepsin
 - c. Bile acids

2. Exogenous
 - a. Ethanol
 - b. Aspirin
 - c. Other NSAIDs.

Protective Factors

Concept

1. Gastric mucosal barrier
2. Cytoprotection

Mediators

- Mucus
 - a. Surface bicarbonate
 - b. Hydrophobic layer
 - c. Mucosal blood flow
 - d. Alkaline tide
 - e. Epithelial renewal
 - f. Restitution
 - g. Prostaglandins
 - h. Epidermal growth factor.

Helicobacter pylori and Peptic Ulcer Disease

- *H. pylori* causes peptic ulcer in the stomach in the region of the gastric antrum, in 70% of the cases.
- In the duodenum, *H. pylori* colonises in that part where there is gastric metaplasia (second part of duodenum) and causes ulcer in that region in 90% of the cases.
- *H. pylori* is a spiral, gram-negative, microaerophilic, urease producing microorganism.
- It is found in the stomach deep within the protective mucus coat covering the gastric epithelial cell. Here it produces for itself an alkaline milieu, by forming ammonia from urea with the enzyme urease, as it thrives in an alkaline medium.

Pathogenesis of Ulcer Production

1. Formation of free hydroxyl radicals produced by combination of ammonia and water. These free radicals disrupt the gastric epithelial integrity thereby producing an ulcer.
2. It has chemotactic properties, attracting neutrophils and monocytes towards itself. The monocytes liberate interleukin I and tumour necrosis factor which disrupt the gastric epithelial integrity.
3. It liberates proteinases and phospholipases which disrupt the protective mucosal coat covering the gastric epithelium, thereby allowing the acid to disrupt the gastric epithelium.



Diagnosis of *H. pylori*

Invasive

1. Microscopic examination of the organism in a gastric biopsy specimen using a Giemsa stain and culture.

Non-invasive

- Urease test:** The specimen containing *H. pylori* is kept in a urea rich medium. The urease produced by the organism converts urea to ammonia, thereby making the medium alkaline. This can be confirmed by using an indicator like phenolphthalein which turns red in the alkaline medium.
- Breath test:** Patient is given ^{13}C or ^{14}C labelled urea. This is converted to ^{13}C or ^{14}C labelled ammonia by the urease producing *H. pylori* and detected in the breath of the patient.
- Elisa test:** This is done to detect antibodies to *H. pylori*.
- Stool antigen test:** Non-invasive tests like urea breath test and stool antigen test are used to assess response to treatment.

**Treatment**

The value of eradicating *H. pylori* infection is debatable, as *H. pylori* infection has been found to occur in asymptomatic patients and have been seen to recur in patients having this infection even after adequate treatment.

It may be recommended for patients with recurrent or complicated ulcers.

Any of the following combinations has to be given for 14 days.

Drugs	Doses
<i>Triple therapy</i>	
1. Bismuth subsalicylate <i>plus</i>	2 tablets QID
Metronidazole <i>plus</i>	400 mg TDS
Tetracycline	500 mg QID
2. Ranitidine bismuth citrate <i>plus</i>	400 mg BD
Tetracycline <i>plus</i>	500 mg QID
Clarithromycin or Metronidazole	500 BD or 400 mg TDS
3. Omeprazole <i>plus</i>	20 mg BD
Clarithromycin <i>plus</i>	250 or 500 mg BD
Metronidazole or	400 mg TDS
Amoxicillin	1 gm BD
<i>Quadruple therapy</i>	
Omeprazole <i>plus</i>	20 mg OD
Bismuth subsalicylate <i>plus</i>	2 tablets QID
Metronidazole <i>plus</i>	400 mg TDS
Tetracycline	500 mg QID

Stress Ulcer

This refers to an ulcer or more commonly multiple ulcers that develop during physiologic stress of serious illness.

Pathogenesis

Pathogenesis is related to a decrease in mucosal blood flow or a breakdown in mucosal defence mechanism.

The ulcer is superficial and confined to the mucosa. It may be located anywhere in the stomach and proximal duodenum but more likely to occur in the fundic mucosa.

Clinical Conditions Producing Stress Ulcer

- Elderly patients in ICU with concomitant heart and lung disease have a high postoperative prevalence of stress ulcer.
- Patients in medical ICU who require respirators.

**Treatment**

- Treatment of underlying illness
- Hourly antacid administration to keep the intragastric pH above 4
- H_2 blocker (IV infusion is better than IV bolus).
Raising the pH above 4 leads to bacterial colonisation of stomach and pharynx, which may lead to development of pneumonia.

NSAID and Peptic Ulcer

These causes mucosal injury and ulceration anywhere in the GIT from oesophagus to duodenum.

**Complications of NSAID (Apart from PUD)**

- Erosive colitis
- Pancreatitis
- Liver damage.

Mechanism of Action

- Direct mucosal injury
- Inhibition of PG (aspirin and NSAID act by inhibition of cyclo oxygenase).
(Steroids produce ulcer either by itself when administered for more than 30 days or when the total dose of prednisolone exceeds 1 gm or when given with NSAID, when the risk of ulceration increases).

**Diagnosis****Upper GI Radiography (Barium Meal Series)**

- Barium is seen within the ulcer niche, surrounded by smooth mound of oedema.
- Secondary changes (folds radiating from ulcer crater and deformities in the region secondary to spasm, oedema and scarring).



Differentiation of Benign from Malignant Ulcer

This depends on the site, size, location and presence or absence of duodenal ulcer.

Site and Location

- Benign gastric ulcer can occur anywhere, but more frequently found on the lesser curvature at the incisura.
- Malignant gastric ulcer can also occur anywhere in the stomach, but a high suspicion of malignancy must be entertained when it is located in the greater curvature of the stomach.
- Malignant ulcer is commonly associated with chronic atrophic gastritis, adenomatous polyp, pernicious anaemia and post surgery for PUD.

Size

The larger the ulcer, the more likely that it is malignant.

Co-existence of Duodenal Ulcer

If gastric ulcer is present along with a duodenal ulcer, it is highly unlikely to be malignant.

Endoscopic Differentiation between Benign and Malignant Ulcer

Signs of Malignancy (Fig. 5.19)

1. Presence of an ulcer within a definitive mass.
2. Effaced, interrupted, fused or nodular mucosal folds as they approach the margin of the crater.
3. Irregular filling defects in the ulcer crater.
4. Friability of ulcer and easy tendency to bleed.

Signs of Benign Ulcer (Fig. 5.19)

1. The mucosal folds, as they approach the edge of the ulcer crater, are seen to be smooth and symmetrical.

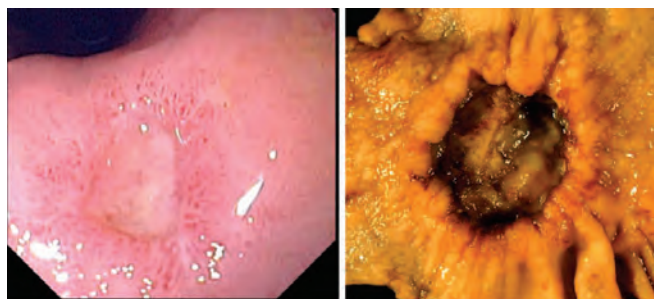

Benign gastric ulcer

Malignant gastric ulcer

Fig. 5.19: Benign and malignant gastric ulcer

2. A smooth mound of oedema surrounding the ulcer.
3. Smooth translucent band or collar surrounding the ulcer crater.



Complications of Peptic Ulcer Disease

1. Upper GI bleed
2. Perforation
3. Gastric outlet obstruction and fluid and electrolyte imbalance
4. Malignancy (with gastric ulcer only)
5. Pancreatitis
6. Gastro-colic fistula.

Zollinger-Ellison Syndrome

- This is a condition in which there is an association of peptic ulcer with a gastrin secreting pancreatic adenoma (or simple islet cell hyperplasia).
- Gastrin excites excessive acid production which can produce multiple ulcers in the duodenum and stomach.
- 50-60% of the gastrin producing pancreatic tumours are malignant.
- 30% of cases are associated with multiple endocrine neoplasia (MEN type 1).
- It is seen in 0.1% of patients with peptic ulcer disease, especially those refractory to treatment.
- This condition must be suspected in those with multiple peptic ulcers resistant to therapy, particularly if there is associated diarrhoea and steatorrhoea.
- On investigation, there is a raised fasting serum gastrin level (> 100 pg/ml) with a raised basal gastric acid output of > 15 mmol/hour (Normal BAO is 1.5-2.0 mmol/hr).
- Gastrinomas may be localised by measuring the uptake of a somatostatin analogue, $^{111}\text{Indium}$ -Pentriotide (Octreoscan).
- This condition is treated with a potassium-hydrogen ATPase inhibitor like omeprazole. The drug is started with a dose of 60 mg/day and then gradually tapered to 20 mg/day as symptoms subside.
- Since the long-term effects of omeprazole use are still unknown, it is worthwhile trying to excise the tumour, which is the definitive treatment for this condition.
- If the tumour turns out to be malignant, then the prognosis is poor, 5-year survival being only 20%.



Treatment of Peptic Ulcer

Drugs	Short-term treatment	Maintenance treatment	Side effects
<i>Antacids</i>			
1. Magnesium containing antacid	30 ml 1 and 3 hours after a meal and at bedtime	Not recommended	Diarrhoea
2. Aluminium containing antacid	30 ml 1 and 3 hours after a meal and at bedtime	Not recommended	Constipation
<i>H₂ receptor antagonist</i>			
1. Cimetidine	800 mg at night or 400 mg bd	400 mg at night	Delays elimination of warfarin, phenytoin and theophylline and should not be used concurrently with these drugs. Rarely causes confusion in the elderly and gynecomastia in males. Both effects reversible on stopping the drug Reversible confusion Sweating, urticaria, somnolence (all rare, none serious) Headache, dizziness, dry mouth (all rare, none serious). Negative cardiac inotropic effect
2. Ranitidine	300 mg at night or 150 mg bd	150 mg at night	
3. Nizatidine	300 mg at night or 150 mg bd	150 mg at night	
4. Famotidine	40 mg at night or 20 mg bd	20 mg at night	
<i>Anti-cholinergics</i>			
Pirenzepine	50 mg bd	Not recommended	Dry mouth, blurred vision
<i>*Site-protective drug</i>			
Sucralfate	2 grams bd	Not recommended	Reduces absorption of warfarin, phenytoin, tetracycline, digoxin
<i>Cytoprotective drug</i>			
1. Misoprostol	200 mg 4 times daily	Not recommended	Abortifacient activity. Avoid use in women of child bearing age. Diarrhoea may occur —do—
2. Enprostil	35 mg 2 times daily	Not recommended	
<i>Proton pump inhibitor</i>			
Omeprazole	20 mg once daily for 4-8 weeks	Not recommended	Delays elimination of diazepam, phenytoin, warfarin. Induces significant hypergastrinaemia, bacterial overgrowth
Lansoprazole	30 mg once daily for 4-8 weeks	Not recommended	
Pantoprazole	40 mg/d	Not required	
Rabeprazole	20 mg/d	Not required	

*It is known as a site protective agent as it forms a protective covering over the ulcer and promotes its healing
Sucralfate should not be combined with antacids, as it is active only in acidic medium.

Management of NSAID induced PUD

Clinical setting	Recommendations
Active ulcer	
NSAID discontinued	H ₂ receptor antagonists/PPI
NSAID continued	PPI
Prophylactic therapy	Misoprostol PPI Selective cox -2 inhibitors
<i>H. pylori</i> infection	Eradicate if active ulcer or past history of PUD

Misoprostol is contraindicated in pregnancy.

Endoscopy

Upper Gastrointestinal Endoscopy

Indications

1. Dysphagia
2. Caustic or foreign body ingestion
3. Dyspepsia
4. Persistent nausea and vomiting
5. Need to obtain small intestine biopsy
6. Acute or chronic gastrointestinal bleeding
7. Inflammatory bowel disease (as this may be associated with duodenal lesions mimicking a duodenal ulcer)



8. Chronic abdominal pain
9. Suspected polyp or cancer.

Contraindications

1. Perforated viscus suspected
2. Patient in shock
3. Combative or uncooperative patient
4. Severe inflammatory bowel disease or toxic megacolon (colonoscopy).

Preparation of the Patient

1. Patient should be fasted for 6 or more hours to ensure an empty stomach.
2. For emergency, nasogastric suction should be done before endoscopy procedure.

Therapeutic Oesophagogastroduodenoscopy

1. In case of upper gastrointestinal bleeding, due to a variceal bleed, endoscopic injection of sclerosants (sclerotherapy) of oesophageal varices is the most widely accepted therapeutic oesophagogastroduodenoscopic procedure.
2. It is also used therapeutically for banding of oesophageal varices.
3. Laser therapy through endoscopy to relieve GI obstruction by malignant growth can be done palliatively.
4. Stenting procedure can be done, thereby providing a lumen through the stent for feeding patients with mechanical obstruction to oesophagus causing dysphagia.



Complications of Endoscopy

1. Perforation of viscus
2. Bleeding
3. Cardiac arrhythmias
4. Reaction to medication (sclerosants)
5. Vasovagal reaction
6. Pulmonary aspiration.

Gastrointestinal Bleeding

Haematemesis

It is defined as the vomiting of fresh blood, either bright red or of coffee ground character.

Melaena

It is a tarry black, sticky, foul smelling stool (Other stool darkeners are iron and bismuth).

Special Features

- a. Approximately 60 ml of blood is required to produce single black stool.
- b. The blood loss > 60 ml produces melaena for more than 7 days.
- c. To produce melaena, the blood must remain in the gut for 8-14 hrs.

Haematochezia

It is the passage of red or maroon blood from the rectum, usually signifies bleeding from a source distal to the ligament of Treitz. It can also occur from massive upper GI bleed from oesophagus, stomach and duodenum.

Tilt Test

- Tilting the head end of the body upwards at an angle of 75° for 3 minutes leads to accelerated heart rate and a drop in systolic blood pressure
- Increase in heart rate of < 20 beats/min and absence of light headedness, indicates slight or compensated blood loss
- Increase in heart rate of > 30 beats/min and presence of faintness or syncope indicates decompensated blood loss and need for restorative measures.

Assessment of Bleed

Blood loss	Clinical features
a. 500 ml	No systemic signs except in elderly and anaemic patients
b. 1000 ml (20% reduction of blood volume)	Tachycardia, orthostatic hypotension, syncope, light headedness, nausea, sweating and thirst
c. 2000 ml or more (40% reduction of blood volume)	Profound shock and possibly death

- Drop in urine output < 0.5 ml/kg/hr indicates moderate to marked hypovolaemia.
- Early sign of cessation of bleeding and restoration of blood volume is return of the normal heart rate.

Aetiology

Duodenal ulcer	35%
Gastric ulcer	20%
Acute gastritis (drugs)	
Erosion/haemorrhagic gastritis	20%
Mallory-Weiss syndrome	5%
Gastric carcinoma	5%
Oesophageal varices	10%
Others	5%

(Leiomyoma, haemophilia, thrombocytopenia, Ehlers-Danlos syndrome, rupture of aorta into stomach, anticoagulants)

**Rockall Risk Scoring System for GI bleeds**

Score	0	1	2
Age	< 60 yr	60–79 yr	80 yr and above
Systolic BP	> 100 mm of Hg	> 100 mm of Hg	< 100 mm of Hg
Pulse rate	< 100/min	> 100/min	
Co-morbidity	No	IHD/cardiac failure	Renal/liver failure
Diagnosis*	Mallory Weiss tear, no lesions or signs of recent bleed	All other diagnosis	Upper GI malignancy
Endoscopic evidence of recent haemorrhage	None/dark red spot		Adherent clot/blood in upper GIT/visible vessel

*The score for metastasis liver is 3.

A score of more than 6 is said to be an indication for surgery

Laboratory Findings

1. *Complete blood count*: Mild leucocytosis and thrombocytosis develop within 6 hrs after the onset of bleeding.
2. *Card test*: It is useful for detection of occult blood in stools.
3. *Endoscopy*: It is useful for confirmation and treatment in more than 90% of cases. Risk of re-bleeding is higher if a 'visible vessel' is seen in ulcer crater.
4. *Angiography*: It is useful to detect the site of bleeding (> 0.5 ml/min).
5. *Radio-labelled RBC*: It is useful in determining low grade bleeding from GI tract and especially when the pathology is out of reach of the endoscope (> 0.1 ml/min).

Differentiation between Upper GI and Lower GI Bleed

Features	Upper GI bleed	Lower GI bleed
Site	Above the ligament of Treitz	Below the ligament of Treitz
Presentation	Haematemesis/melaena	Haematochezia
Nasogastric aspiration	Blood	Clear fluid
BUN/creatinine ratio	Increased (> 25:1)	Normal (< 25:1)
Bowel sounds	Hyperactive	Normal

**Management**

1. Admission of the patient
2. Reassure the patient
3. Establish an IV line
4. Assessment of blood loss by history and vital signs (HR, BP every hour)

5. Introduction of a nasogastric tube for assessment of the quantity and duration of bleed and can also be used for therapeutic cold water lavage in an attempt to arrest the bleed
6. Cross matching of blood to be done and haematocrit value to be determined
7. Indication for transfusion of blood
 - a. Acute or continuous blood loss
 - b. Patient in shock (HR > 120/min; systolic BP < 100 mm Hg; hourly urine output < 0.5 ml/kg/hr)
 - c. Hb < 10 gm% } limited value in the
 - d. PCV < 20% } assessment of acute bleed
8. *Therapeutic endoscopy*: The technique is useful for control of bleeding (coagulating electrodes, heated probes and laser energy).
9. Sengstaken-Blakemore's tube (for variceal bleed).

Poor prognostic factors are

1. Severe initial bleed based on transfusion requirements and the presence of shock
2. Continuous bleeding
3. Recurrent bleeding
4. Onset of bleeding during hospitalisation
5. Age over 60 years
6. Presence of other diseases (cardiac, respiratory, renal)
7. Variceal bleeding.

Diarrhoea

It is defined as an increase in daily stool weight more than 200 gm. Typically the patient may also describe an increase in stool liquidity and frequency of more than 3 bowel movements per day.

If consistency is liquid or semiformed, even one episode is considered as diarrhoea.



Mechanism of Diarrhoea

- Osmotic diarrhoea* is due to increased amounts of poorly absorbable osmotically active solutes in the gut lumen.
- Secretory diarrhoea* is due to secretion of chloride and water with or without inhibition of normal active sodium and water absorption.
- Exudation of mucus, blood and protein from sites of active inflammation into bowel lumen.
- Abnormal intestinal motility when an increased or decreased contact between luminal contents and mucosal surface.

Osmotic Diarrhoea



Clinical Features

- Osmotic diarrhoea stops when patient fasts.
- Serum osmolality is less than the osmolality of the stool fluid.
- Osmotic gap >125 milliosm/L
Osmotic gap is calculated by the formula: $290 - 2 \times \text{stool } (\text{Na}^+ + \text{K}^+)$
- pH

Carbohydrate in stool	acid pH
Milk of magnesia	alkaline pH
Poorly absorbable salt containing magnesium and sulphate	neutral pH

 e.g. carbohydrate malabsorption, antacids and laxatives containing Mg^{++} .

Secretory Diarrhoea



Clinical Features

- Stool volume > 1 litre/day
 - Stool is watery in consistency
 - Stool does not contain pus or blood
 - Diarrhoea continuous, even when patient fasts for 24-48 hours but stops when agents causing fatty acid malabsorption or laxatives are not ingested.
 - Osmotic gap < 50 milliosm/L
In mixture of osmotic and secretory diarrhoea, the osmotic gap will be between 50 and 125.
- e.g.
- Infections due to enterotoxigenic bacteria, chronic mycobacterial fungal or parasitic infections.
 - Following use or abuse of stimulant laxatives
 - Intestinal resections
 - Inflammatory bowel diseases
 - Coeliac sprue
 - Lymphoma of small intestine

- Zollinger-Ellison syndrome, VIPoma, glucagonoma
- Malignant carcinoid syndrome
- Hyperthyroidism
- Collagen vascular diseases (SLE, scleroderma, MCTD).

Clinical Classification of Diarrhoea

Acute Diarrhoea

Diarrhoea of abrupt onset of < 2 weeks of duration.



Causes

- Bacterial infection
 - Vibrio cholerae*
 - Toxigenic *E. coli*
 - Salmonella*
 - Shigella*
 - Campylobacter*
 - Yersinia enterocolitica*
 - Invasive *E. coli*
- Viral infection
 - Rota virus
 - Adenovirus
 - Norwalk agent
- Parasitic infection
 - Giardia lamblia*
 - Cryptosporidium*
 - Entamoeba histolytica*
- Drugs
 - Laxatives
 - Sorbitol
 - Antacids
 - Lactulose
 - Colchicine
 - Quinidine
 - Diuretics
 - Digitalis
 - Propranolol
 - Theophylline
 - Alcohol
 - Antibiotics
 - Heavy metals
- Food poisoning
Most common cause of acute diarrhoea is infection.

Diarrhoea in HIV

It is due to cryptosporidium, microsporidium, CMV, mycobacterium avium complex, TB, intestinal lymphoma and Kaposi sarcoma.



Investigations

- Examination of the stool*
 - Presence of WBC in stool suggests intestinal inflammation as a result of a mucosal invasion



with bacteria, parasite or toxin and are also seen in ischaemic colitis and IBD (inflammatory bowel disease)

- b. Absence of leucocytes in the stool suggests non-inflammatory, non-invasive process (viral infection, giardiasis, drug related)
 - c. Occult or gross blood in the stool suggests the presence of a colonic neoplasm, an acute ischaemic process, radiation enteritis, amebiasis or severe mucosal inflammation
 - d. *Bacteria and parasitic organisms*: Fresh stool sample must be examined for the presence of ova and parasites. Organisms that colonise the upper GI may not be found in stool sample and duodenal or jejunal aspirates or biopsies or the string test may be required. Stool culture will help to determine the bacterial pathogens in most cases. Special techniques are necessary. Example *Yersinia, Campylobacter*.
2. *Sigmoidoscopy or Colonoscopy*: It is useful in evaluation of
 - a. Bloody diarrhoea
 - b. Diarrhoea of uncertain aetiology
 - c. Inflammatory bowel disease, pseudomembranous colitis, pancreatic disease or laxative abuse (melaenosis coli).



Treatment

1. Rehydration.
2. There is no restriction of food intake. Temporary milk intolerance may occur due to secondary lactase deficiency.
3. Antidiarrhoeal drugs such as codeine phosphate, diphenoxylate or loperamide should be avoided in moderate to severe diarrhoea because they prolong the infection.
4. Antibiotic choice depends on the causative pathogen. A guideline to antibiotic choice is given below.
5. Racecadotril: It decreases hypersecretion of water and electrolytes into the intestinal lumen by preventing degradation of enkephalins. It is a potent inhibitor of enkephalinase. This drug is given at a dose of 100 mg TID in acute watery diarrhoea of either bacterial or viral aetiology. It is contraindicated in renal insufficiency, pregnancy, and breast-feeding state.
6. Octreotide is useful in hormone induced secretory diarrhoea and refractory diarrhoea.

Pathogens	Antibiotic
<i>Salmonella</i>	Ampicillin, Cotrimoxazole, Amoxicillin
<i>Shigella</i>	Cotrimoxazole, Amoxicillin, 4-Fluoroquinolones
<i>Yersinia</i>	Tetracycline
<i>Campylobacter</i>	Erythromycin, Tetracycline
<i>Clostridium difficile</i>	Vancomycin, Metronidazole
<i>Giardia lamblia</i>	Metronidazole, Tinidazole
<i>E. histolytica</i>	Metronidazole, Tinidazole, Secnidazole

Differentiation between Small Bowel and Large Bowel Diarrhoea

Features	Small bowel diarrhoea	Large bowel diarrhoea
Volume of stool	Large	Small
Colour of stool	Light	Dark
Smell of stool	Very foul	Foul
Nature of stool	Soupy and greasy	Mucinous or jelly like
Type of stool	Watery	Mucoid
Blood in stool	Rare	Common
WBCs in stool	Rare	Common
Location of abdominal pain	Mid abdomen (crampy and intermittent)	Lower abdomen (gripping and continuous)
Tenesmus	Absent	Present
Common pathogens	<i>Vibrio cholera</i> <i>E. coli</i> Rota virus, Norwalk virus <i>Campylobacter</i> <i>Giardia</i>	<i>Shigella</i> <i>E. histolytica</i>

Chronic Diarrhoea

Diarrhoea of > 4 weeks duration.



Causes

1. Infection
2. Inflammatory bowel disease
3. Drugs
4. Malabsorption
5. Endocrine
 - a. Zollinger-Ellison syndrome
 - b. Hyperthyroidism
 - c. Carcinoid
 - d. Non- β cell pancreatic tumour
 - e. Villous adenoma
6. Motility disorder
 - a. Irritable bowel syndrome
 - b. Post-vagotomy syndrome.



Differentiation between Amoebic and Bacillary Dysentery

Features	Amoebic dysentery	Bacillary dysentery
Number of stools per day	6 to 8 motions per day	More than 10 per day
Amount	Relatively copious	Small quantity
Odour	Offensive	Odourless
Colour	Dark red	Bright red
Nature	Blood and mucus mixed with faeces	Blood and mucus (with minimal faecal matter)
Reaction	Acid	Alkaline
Consistency	Not adherent to the container	Adherent to the container
<i>Microscopic examination</i>		
a. RBC	In clumps	Discrete
b. Pus cells	Scanty	Numerous
c. Macrophage	Very few	Numerous
d. Eosinophils	Present	Absent
e. Parasite	Trophozoites of <i>E. histolytica</i>	Nil

Malabsorption

Malabsorption refers to defective mucosal absorption of essential nutrients, electrolytes, minerals and vitamins. It can be due to defects in the

- Luminal phase
- Mucosal phase
- Transport phase of absorption of nutrients.

Luminal Phase

Defect in Substrate Hydrolysis

- Enzyme deficiency Chronic pancreatitis and pancreatic carcinoma
- Enzyme inactivation Zollinger-Ellison syndrome
- Rapid transit/asynchrony Post-gastric surgery

Defect in Fat Solubilisation

- Decreased bile salt synthesis Parenchymal liver disease
- Impaired biliary secretion Cholestatic jaundice
- Bile salt deconjugation, precipitation and binding Bacterial over growth; Zollinger-Ellison syndrome
- Increased bile salt loss Terminal ileal resection or disease

Defect in Luminal Availability and Processing

- Lack of intrinsic factor Pernicious anaemia
- Consumption of B₁₂ due to bacterial over growth Blind loop syndrome; prolonged use of proton pump inhibitor

Mucosal Phase

Defect in Brush Border Hydrolysis

Disaccharidase deficiency—primary or secondary.

Defect in Epithelial Transport

- Isolated defects Hartnup disease, cystinuria, congenital vitamin B₁₂ and folate deficiency
- Global defects Intestinal resection; Diffuse mucosal disease
 - Coeliac disease
 - Tropical sprue
 - Crohn's disease
 - Radiation
 - Ischaemia
 - Whipple's disease
 - AIDS

Defect in Epithelial Processing

Abetalipoproteinaemia

Transport Phase

- Lymphatic Obstruction, lymphangiectasia, primary or secondary nodal disease
- Vascular Intestinal ischaemia (atheroma, vasculitis).

Principles of Management

- Correction of nutritional deficiencies
- Treatment of the underlying disorder.

Tuberculosis of Abdomen

It commonly affects ileocaecal area in 70% of the patients. The other regions affected in decreasing order of frequency are ascending colon, jejunum, appendix, sigmoid colon, rectum, duodenum, stomach and oesophagus.

Pathological Types

Ulcerative (60%)

- Multiple superficial lesions confined largely to the epithelial surface (virulent process).
- The long axis of the ulcer is perpendicular to the long axis of the GI segment involved and hence it is prone for stricture formation (the long axis of the ulcer produced in enteric fever lies parallel to the long axis of the GI segment involved).

Hypertrophic (10%)

It is common in ileocaecal region. The feature consists of scarring, fibrosis, heaped up mass lesion that may

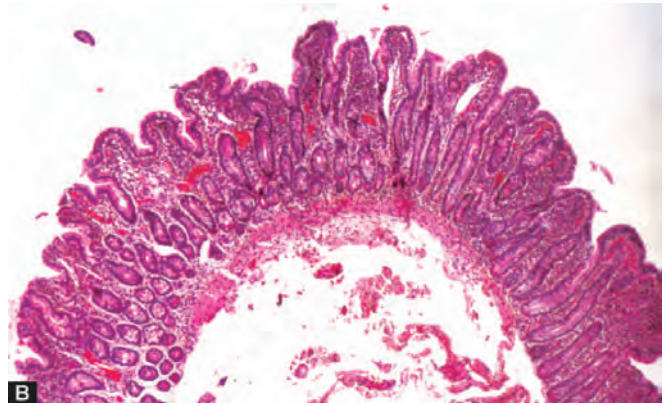
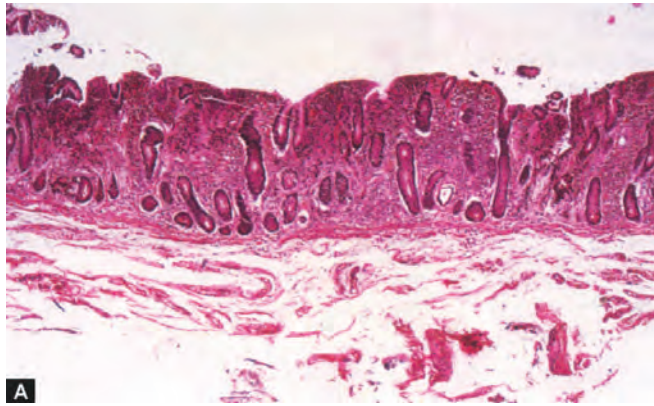

Figs 5.20A and B: (A) Coeliac sprue-jejunal mucosal biopsy flat mucosal surface with absent villi (B) Improvement after treatment

Clinical Features

Malabsorbed nutrients	Symptoms and signs
Fat	Frothy stools, watery diarrhoea, weight loss
Protein	Weight loss, muscle wasting, oedema, leuconychia
Carbohydrate	Abdominal distension, borborygmi, watery diarrhoea, flatus
Iron	Anaemia, glossitis, cheilosis, koilonychia, aphthous ulcer
Folic acid	Anaemia, glossitis
Vitamin B ₁₂	Anaemia, glossitis, neurological sequelae
Vitamin A	Hyperkeratosis, night blindness
Vitamin D	Rickets, osteomalacia, proximal myopathy
Vitamin K	Bruising and bleeding
Calcium	Paraesthesia, tetany
Magnesium	Paraesthesia, tetany
Zinc	Poor taste, acrodermatitis, poor wound healing
Bile salts	Watery diarrhoea

Small Intestine Biopsy

Diseases	Biopsy findings
Coeliac disease (Fig. 5.20)	Subtotal or partial villous atrophy
Dermatitis herpetiformis	Subtotal or partial villous atrophy
Tropical sprue	Partial villous atrophy
Whipple's disease	PAS-positive macrophages
Intestinal lymphomas	Infiltrate of abnormal lymphoid cells
Parasitic infections	Giardia, strongyloides or coccidia may be seen
Lymphangiectasia	Dilated lymphatics

mimic carcinoma and is palpable as a thickened and bulky mass.

Ascitic

Peritoneal tuberculosis is a common mode of presentation of abdominal tuberculosis. It is believed that

Drugs and Malabsorption

Drugs	Mechanisms
Colchicine	Inhibits crypt cell division and disaccharidases
Neomycin and other related antibiotics	Reduces crypt cell replication, precipitates bile salts and micellar fatty acids; inhibits disaccharidases
Methotrexate	Folate antagonist ± direct toxicity
Cholestyramine	Binds bile salts
Laxatives, PAS, biguanides	Inhibits mucosal enzyme transport activity
Alcohol	Pancreatic insufficiency; direct enterocyte toxicity; chronic liver disease

Systemic Disease Associated with Malabsorption

Diseases	Mechanisms
Thyrotoxicosis	Hyperphagia and rapid transit
Hypothyroidism	Variable villous atrophy; Pancreatic insufficiency
Addison's disease	Unclear
Hypoparathyroidism	Minor mucosal changes; occasional monilial infection
Diabetes mellitus	Pancreatic insufficiency; autonomic neuropathy; bacterial overgrowth
Collagen vascular disorders	Variable villous atrophy; amyloidosis; bacterial overgrowth

lymphatic spread from an intestinal focus may lead to peritoneal involvement. It manifests with rigidity of the abdominal wall and tenderness. The fibroblastic bands and adhesions sometimes obstruct the bowel loops and produce features of subacute intestinal obstruction.

Lympho-glandular

The predominant involvement is of the mesenteric lymph nodes. The nodes become enlarged and palpable as multiple rounded masses (tabes mesenterica). This is



Test of Malabsorption

Nutrient tested	Tests	Normal value
1. Fat	a. Measurement of fat in a 5-day collection of stool b. The synthetic bile acid is given orally and its retention is measured at 7 days by whole body counting	Excretion < 7 g/day Retention > 90%. (In severe ileal disease, retention is < 20%)
2. Carbohydrate	a. <i>Lactose tolerance test</i> : 50 g of lactose is given orally and blood samples are taken every 20 min for 2 hours b. <i>Hydrogen breath test</i> : 50 g of lactose is given orally and breath hydrogen is measured every hour for 4 hours	Rise in blood glucose > 20 mg/dL Less than 10 ppm above baseline in any sample
3. Protein	a. <i>Faecal clearance of endogenous α_1 antitrypsin</i> : This normal serum protein is excreted unchanged in the stool when there is any protein loss into the stool and is therefore measured in a 3-day collection of stool	No α_1 antitrypsin in the stool
4. Vitamins	Vitamin B ₁₂ absorption: 0.5 μ g of radiolabelled vitamin B ₁₂ is given orally followed 2 hours later by 1000 μ g of non-radioactive vitamin B ₁₂ given by intramuscular injection. Urine is collected for 24 hours	More than 16% of radioactivity appears in the urine
5. Small intestinal culture		< 10 ⁵ organisms/ml

more common in young adults and is often confused with abdominal lymphoma.



Clinical Features

Chronic abdominal pain (80-90%), diarrhoea and occasionally blood in the stool. Abdominal mass in the right iliac fossa may be palpated.



Complications

Haemorrhage, perforation, obstruction, fistula formation and malabsorption.



Investigations

Radiology

Plain X-ray of the abdomen

1. Calcified lymph nodes
2. Multiple fluid levels
3. Distended gas filled loops of the intestine or enteroliths.

Barium meal and enema

1. Hypermotility
2. 'Stierlin sign'—a defect characterised by failure of the diseased segment to retain barium which is adequately retained by adjacent areas free of disease.
3. 'String sign'—a thin stream of barium resembling a string may be commonly seen in the terminal ileum.

Ascitic Fluid Examination

- a. The ascitic fluid is an exudate.

- b. Punch biopsy of the peritoneum reveals tuberculous lesion.

Diagnosis

1. Definite diagnosis by demonstration of organism in the specimen.

Distinguishing Features between Tuberculosis and Crohn's Disease

Features	Tuberculosis	Crohn's disease
<i>Clinical</i>		
1. Duration	Months	Years
2. Course	Continuous	Remissions and exacerbations
3. Fever	Common	Less common
4. Diarrhoea	Common (constipation may occur)	Very common
5. Lump abdomen	Palpable	Not palpable
6. Ascites	Common	Uncommon
7. Fistulae (internal and external)	Rare	Common
8. Rectal and peri-rectal fistula	Rare	Common
9. Pulmonary lesion	May be present	Not present
<i>Macroscopic</i>		
10. Anal lesions	Rare	Common
11. Miliary nodes on serosa	Common	Rare
12. Length of stricture	Small	Long
13. Ulcers	Annular	Serpiginous
<i>Microscopic</i>		
14. Caseation	Usually Present	Absent
15. Acid fast bacilli	Often present	Absent
16. Fibrosis	Common	Less common

2. Radiological features
 - a. Thickened mucosa with distortion of mucosal folds
 - b. Ulcerations
 - c. Stenosis of the bowel
 - d. Pseudopolyp formation.



Differential Diagnosis

1. Crohn's disease
2. Tropical sprue
3. Chronic amoebiasis
4. Roundworm infestation
5. Lymphomas
6. Large bowel malignancy.



Treatment

Treat with 3 drug regimen of ATT for 6 months.

Inflammatory Bowel Disease

It refers to idiopathic and chronic intestinal inflammations. Ulcerative colitis and Crohn's disease are the two main types of IBD.

Differentiation between Ulcerative Colitis and Crohn's Disease

Features	Ulcerative colitis	Crohn's disease
Pain	Crampy lower abdominal pain and relieved by bowel movement	Constant pain; often in right lower quadrant and not relieved by bowel movement
Stool	Usually bloody	Stool usually not grossly bloody
Abdominal mass	No mass palpable	Mass often felt in right lower quadrant
Site of involvement	Affects colon only	May affect small and large bowel; occasionally stomach and oesophagus may be involved
Pathology	Mucosal disease (granuloma is not a feature)	Transmural disease (granulomas are sometimes seen)
Nature of involvement	Involvement of bowel continuous from rectum	Usually discontinuous involvement of bowel (skip areas)

Special Clinical Features to Crohn's Disease

1. Gallstones
2. Renal oxalate stones
3. Vitamin B₁₂ deficiency

Extraintestinal Manifestations of IBD (Common to Both Ulcerative Colitis and Crohn's Disease)

Areas	Conditions
Joints	Peripheral arthritis Sacroilitis Ankylosing spondylitis
Skin	Erythema nodosum Pyoderma gangrenosum
Eyes	Conjunctivitis Episcleritis Iritis
Liver	Fatty infiltration Chronic active hepatitis Pericholangitis Sclerosing cholangitis Bile duct carcinoma
Kidney	Pyelonephritis Renal stone
General	Amyloidosis

4. Obstructive hydronephrosis.
5. Thromboembolic episode
6. Hypercoagulable state
7. Endocarditis
8. Myocarditis
9. Pleuropericarditis
10. Interstitial lung disease



Differential Diagnosis of IBD

1. Bacterial colitis (*Campylobacter*, *Shigella*, *Salmonella*, *E. coli*, *Clostridium difficile*)
2. Parasitic colitis (amoebiasis and schistosomiasis)
3. Ischaemic colitis
4. Radiation colitis
5. Behcet's colitis
6. Sexually transmitted colitis (*Gonococcus*, *Chlamydia*, herpes and trauma)
7. Condition simulating Crohn's disease
 - a. Lymphoma
 - b. *Yersinia* infection
 - c. Tuberculosis.

Onset and Course of Symptoms

Both begin in childhood or early adulthood. Patients with ulcerative colitis experience intermittent exacerbations and almost complete remissions between attacks. Patients with Crohn's disease have recurrent symptoms of varying duration with history of growth retardation and failure to develop sexual maturity.

Physical Examination

Thin and under nourished, pallor (due to blood loss), low grade fever, mild to moderate abdominal tenderness



(characteristic of ulcerative colitis), tenderness in right lower quadrant (characteristic of Crohn's disease).



Investigations

Laboratory

- a. Complete blood count (anaemia due to blood loss, leucocytosis)
- b. ESR (Increased correlating with disease severity)
- c. *Electrolytes*
 - Hyponatraemia
 - Hypokalaemia
 - Acidosis
 - Hypocalcaemia and
 - Hypomagnesaemia
- d. *Stool examination*
 - Faecal leucocytes (not common in IBS)
 - Ova and parasites
 - Stool culture for bacterial pathogens.

Sigmoidoscopy

Ulcerative colitis (Fig. 5.21)

- Mucosal surface becomes irregular and granular.
- Mucosa becomes friable and bleeds on touch.
- In chronic condition pseudopolyps may be seen.

Crohn's disease

Rectal mucosa is normal.

Mucosal Biopsy

Ulcerative colitis

- Infiltration of mucosa with inflammatory cells
- Flattening of the surface epithelial cells
- Decreased goblet cells
- Thinning of mucosa, branching of crypts
- Crypt abscesses.

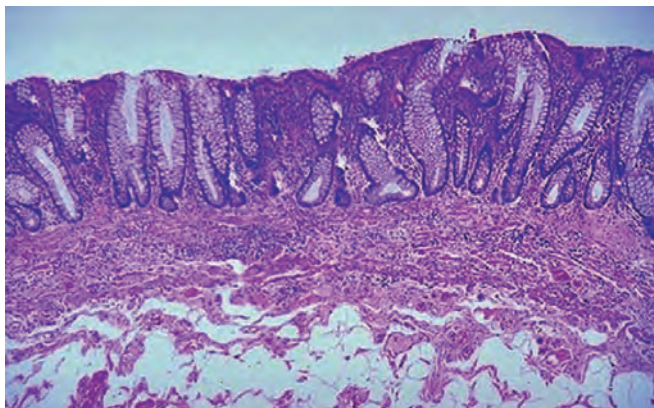

Fig. 5.21: Colitis—microscopic view



Fig. 5.22: Barium enema—loss of colonic haustrations in ulcerative colitis

All these above findings including the crypt abscess may be seen in Crohn's disease and other colitis.

Crohn's disease

Granulomas are seen.

Radiography

a. *Plain film of the abdomen*

Ulcerative colitis: Loss of haustral markings and shortening of bowel is seen in severe lesion (Fig. 5.22).

Crohn's disease: Narrowing of bowel lumen is seen.

b. *Barium enema:* It is contraindicated in toxic megacolon.

In Ulcerative Colitis

- a. Loss of haustration (pipe stem appearance)
- b. Ulcerations
- c. Pseudopolyps
- d. Shortening of bowel is seen.

In Crohn's disease skip lesions can be seen. Rose thorn appearance (linear fissures throughout bowel), string sign (tubular narrowing of terminal ileum), cobble stone appearance (ulcero nodular pattern), omega sign (concentric lesions) are also seen.

c. *Ultrasonogram:* USG shows Bull's eye appearance in transverse section of two thickened loops in Crohn's disease.



Treatment Protocol for IBD

Ulcerative Colitis: Active diseases				
	<i>Mild</i>	<i>Moderate</i>	<i>Severe</i>	<i>Fulminant</i>
Distal	5-ASA oral and/or enema	5-ASA oral and/or enema Glucocorticoid enema Oral glucocorticoid	5-ASA oral and/or enema Glucocorticoid enema Oral or IV glucocorticoid	Intravenous glucocorticoid Intravenous CSA
Extensive	5-ASA oral or enema	5-ASA oral and/or enema Glucocorticoid enema Oral glucocorticoid	5-ASA oral and/or enema Glucocorticoid enema Oral or IV glucocorticoid	Intravenous glucocorticoid Intravenous CSA
Ulcerative Colitis: Maintenance therapy				
Distal	5-ASA oral and/or enema 6-MP or azathioprine			
Extensive	5-ASA oral and/or enema 6-MP or azathioprine			
Crohn's Disease: Active disease				
<i>Mild-Moderate</i>	<i>Severe</i>		<i>Perianal or fistulising disease</i>	
5-ASA oral or enema Metronidazole and/or ciprofloxacin Oral glucocorticoids Azathioprine or 6-MP Infliximab	5-ASA oral or enema Metronidazole and/or ciprofloxacin Oral or IV glucocorticoids Azathioprine or 6-MP Infliximab TPN or elemental diet Intravenous cyclosporine		Metronidazole and/or ciprofloxacin Azathioprine or 6-MP Infliximab Intravenous CSA	
Crohn's Disease: Maintenance therapy				
<i>Inflammatory</i>	<i>Perianal or fistulising disease</i>			
5-ASA oral or enema Metronidazole and/or ciprofloxacin Azathioprine or 6-MP	Metronidazole and/or ciprofloxacin Azathioprine or 6-MP			

Note: CSA—cyclosporine; 6-MP—6-mercaptopurine; TPN—total parenteral nutrition

<i>Oral 5 ASA preparations:</i>	<i>GM/day:</i>	
	<i>Acute phase</i>	<i>Maintenance phase</i>
Sulphasalazine	4-8	2-6
Olsalazine	1-3	
Balsalazine	2.25 -6.75	
<i>Delayed release preparations:</i>		
Asacol	2.2-4.8	1.6-4.8
Claversal	1.5-3	0.75-3
<i>Sustained release preparation:</i>		
Pentasa	2-4	1.5-4

Colonoscopy and Upper GI Endoscopy

- Colonoscopy is useful in assessing progression of proctitis or colitis. It is also useful for screening for development of cancer and early detection of precancerous lesions.
- Upper GI endoscopy is useful in differentiating Crohn's disease of duodenum from peptic

ulcer disease, which it may mimic symptomatically.

Liver Function Tests

- Increased alanine transaminase (chronic active hepatitis)
- Increased alkaline phosphatase (sclerosing cholangitis).



Treatment

Medical

Diet and Nutrition

1. Avoid high fibre diet in presence of diarrhoea/dysentery
2. Diet should be nutritious
3. Supplemental fat soluble vitamins, medium chain triglycerides and parenteral vitamin B₁₂
4. In severe inflammation
 - a. Nothing by mouth
 - b. Total parenteral nutrition.

Drugs

1. Sulfasalazine started with 1 gm/day and increased to a maximum of 4 gm/day in advanced cases of ulcerative colitis and in Crohn's disease with colonic involvement.
2. *Corticosteroids*
 - a. In ulcerative colitis, it is indicated only when sulfasalazine is not effective.
 - b. In Crohn's disease, it is the first drug of choice. Dose is 40-60 mg/day and is gradually tapered and withdrawn after improvement.

Steroid enema is given when proctitis and distal colitis are present.

Parenteral glucocorticoids can be administered as hydrocortisone 300 mg/day or methylprednisolone 40-60 mg/day. ACTH is occasionally preferred for glucocorticoids.
3. *Immunosuppressants*:
 - a. Azathioprine: 50-100 mg/day
 - b. 6 mercaptopurine
 - c. Cyclosporine
 - d. Methotrexate—for remission 25 mg/week
For maintenance 15 mg/week.
4. *Antidiarrhoeals*: If no improvement of diarrhoea with steroids and sulfasalazine, codeine and lomotil may be used.
5. *Metronidazole*: It is an alternative to immunosuppressants and helps in reducing steroid usage. Dose 200 mg 4 times/day.
6. Bile acid binding resins and medium chain triglycerides are used in terminal ileum involvement in ulcerative colitis.
7. Antibiotics are indicated in toxic megacolon and severe ulcerative colitis.
8. Newer drugs:
 - a. Infliximab—Anti-TNF antibody
 - b. Tacrolimus

- c. Mycophenolate mofetil
- d. Thalidomide
- e. Natalizumab— α 4 integren specific humanized monoclonal antibody.

Psychotherapy

Surgery

Ulcerative Colitis

Indications

- a. Acute UC not responding to medical treatment
- b. Relapsing and remitting disease
- c. Responding poorly to drug therapy
- d. Complications
 - Perforation
 - Abscess
 - Uncontrollable haemorrhage
 - Unrelieved obstruction
 - Fulminating disease
 - Carcinoma.
- e. Toxic megacolon—If medical management is not effective in 10 days, total colectomy is indicated.

Procedure: The most common operation is pancolectomy with ileostomy.

Indications in Crohn's disease

Perforation
Abscess
Unrelieved obstruction
Unresponsiveness to medical treatment
Intractable disease
Fistulae.

Irritable Bowel Syndrome

Irritable bowel syndrome is the most common of all digestive disorders, affecting nearly everyone at one time in their life.



Clinical Features

Diagnostic criteria for diagnosing irritable bowel syndrome is at least three months of continuous or recurrent symptoms of abdominal pain or discomfort which is

- a. Relieved with defaecation and/or
- b. Associated with change in frequency of stool and/or
- c. Associated with a change in consistency of stool.

The above symptoms may be described by the patient as follows:

- Altered bowel frequency (> 3 bowel movements a day or < 3 bowel movements a week)
- Altered form of stool (lumpy/hard or loose/watery stool)
- Altered passage of stool (straining urgency or feeling of incomplete evacuation)
- Passage of mucus
- Bloating or feeling of abdominal distension.



Investigations

All Patients

- Stool for occult blood series
- If diarrhoea is present, stool for leukocyte, ova, parasites, bacterial pathogens
- Sigmoidoscopy
- Barium enema examination.

Selected Patients

- Upper GI and small-bowel endoscopy
- Ultrasound of gallbladder
- Abdominal CT scan
- Serum amylase level
- Lactose tolerance test
- Mucosal biopsy of small bowel or colon.

Nocturnal and bloody diarrhoea are against diagnosis of irritable bowel syndrome.



Management

For all patients:

- Reassurance and emotional support
- Stress reduction
- Avoid tranquilisers and antidepressants.
- Low dose tricyclic antidepressants may be tried.

Patients with abdominal pain and constipation:

- Increase the dietary fibre
- Avoid laxatives
- Anticholinergics or antispasmodics.

Patients with diarrhoea:

- Antidiarrhoeal agents
- Increase the dietary fibre.

Ischaemic Colitis

This is due to occlusion of the inferior mesenteric artery leading to ischaemia of the left colon.

Patient presents with colicky lower abdominal pain, nausea, vomiting and diarrhoea with the passage of blood and mucus. On examination, there is tenderness and guarding in the left iliac fossa. This episode may be transient or persistent leading to stricture formation. Some patients may present with shock and generalised abdominal pain simulating peritonitis.

A plain radiograph of the abdomen shows thumb printing at the splenic flexure and descending colon which are indentations of the bowel wall from sub-mucosal haemorrhage and oedema. A double contrast barium enema demonstrates the distribution of maximal involvement.

Most cases resolves with conservative management. Surgery is necessary when there are signs of peritonitis or when symptomatic stricture develops.

Carcinoid Tumours

Carcinoid tumours are of argentaffin cell origin and occur at many sites in the gastrointestinal tract but are most common in the appendix, the ileum and the rectum. In small intestine they are multiple. Twenty per cent of these show low-grade malignancy with metastases to the abdominal lymph nodes and the liver (rarely gallbladder, bronchus or gonads).

Carcinoid syndrome refers to the systemic manifestations produced by the secretory products of the neoplastic enterochromaffin cells (serotonin (5HT), 5-HIAA, kinins).



Clinical Features

- Symptoms are due to local invasion of the bowel or hepatic metastases
- Flushing* (after alcohol, coffee, various foods or drugs)
- Diarrhoea
- Right heart valvular lesions** (tricuspid incompetence, tricuspid stenosis, pulmonary stenosis)
- Hepatomegaly due to metastases
- Oedema
- Asthma (due to bronchospasm).

Note: *There are 4 kinds of flushes

- Paroxysmal erythema
- Facial telangiectasia
- Prolonged flushes, e.g. for 48 hours (suggests bronchial carcinoid)
- White and red patches (suggests gastric carcinoid).

**Left heart valvular lesions can occur when there is a large bronchial carcinoid as the venous effluent enters the left heart without getting inactivated in the lung.



Investigations

1. The estimation of urinary 5-HIAA in a 24-hour collection of urine is more than 15 mg.
2. CT and laparotomy are useful for localisation.
3. A gulp of whisky may help diagnostically by inducing the flush.



Management

Medical Treatment

1. Methysergide 2 mg/8 hours per oral (blocks 5 HT); may cause retroperitoneal fibrosis.

2. Cyproheptadine 4 mg/8 hour per orally prevents diarrhoea.
3. Phenoxybenzamine 20-200 mg/24 hours per orally prevents flushing.

Surgical Treatment

The treatment of carcinoid syndrome is usually palliative because hepatic metastases occurs earlier. In the absence of metastases, surgical removal of the tumour may be done.

Prognosis

Median survival is 5-8 years and 30 months if metastases are present.

Gastrointestinal Malignancies

<i>Sites, incidence and types</i>	<i>Predisposing factors</i>	<i>Clinical features</i>	<i>Investigations</i>	<i>Management</i>
<i>Oesophagus</i> Upper; least common; squamous cell carcinoma Middle; less common; squamous cell carcinoma Lower; common; adenocarcinoma	Tobacco (smoked or chewed) Alcohol, achalasia Paterson-Kelly Syndrome; Barrett's epithelium (smoking)	Progressive dysphagia, sticking of solid food, or upper GI bleed	Barium swallow; Oesophagoscopy	Radiation therapy Oesophagogastrctomy
<i>Stomach</i> Pylorus or antrum; 60%; adenocarcinoma Body; 20-30%; adenocarcinoma	Food preservatives (nitrites) pernicious anaemia <i>H. pylori</i>	Anaemia, asthenia, anorexia, dyspepsia, vomiting, weight loss	Barium meal; OGD; biopsy	Gastrectomy Chemotherapy
<i>Small Intestine</i> Duodenum or jejunum	Coeliac disease; Crohn's disease; multiple polyposis syndromes	Abdominal pain, weight loss, bleeding, obstruction or intussusception	Barium meal series	Surgical
<i>Large Intestine</i> Ascending colon; adenocarcinoma Descending colon; adenocarcinoma Rectum; adenocarcinoma	Ulcerative colitis Familial polyposis (Adenomatous polyp) Rich lymphatics predisposes to early spread of carcinoma	Most common malignancy of GIT (western) anaemia (occult bleeding) cachexia altered bowel habits and late obstruction Frank blood in the stool and obstruction early Early bleeding and mucous discharge; tenesmus	Rigid sigmoidoscopy, double contrast barium enema Colonoscopy Proctoscopy and sigmoidoscopy	Surgical Surgical Surgical
<i>Pancreas</i> Head; 60%; adenocarcinoma Body and Tail; 20%; adenocarcinoma	Smoking, high dietary fat, occupational exposure in chemical and metal industries	Epigastric pain (common) Gastrointestinal haemorrhage, diarrhoea, jaundice, abdominal mass	Raised serum alkaline phosphatase, barium meal ERCP, USG, duodenoscopy	Surgical

Gastric Ulcer and Malignancy

- Both ulcer and malignancy are common in the lesser curvature of the stomach.
- Presence of an ulcerating mass or a large ulcer > 3 cm in diameter suggests the probability of malignancy.
- Gastric ulcer with pentagastrin fast achlorhydria indicates malignancy.
- Improper preservation or refrigeration or ingestion of contaminated food leads to bacterial conversion of dietary nitrates to carcinogenic nitrites.
- Biopsy must be performed in the management and follow-up of patients with isolated gastric ulcer.

Hepatology and Pancreas

Hepatic Segments

The liver is divided into a functional right lobe and the left lobe by an imaginary line drawn between the gall bladder fossa and middle hepatic veins. For the purpose of functional anatomy, the liver has been divided into 8 segments. Each of these segments can be considered as functional units, each with a branch of hepatic artery, portal vein, bile duct and drained by a branch of hepatic vein (Fig. 5.23).

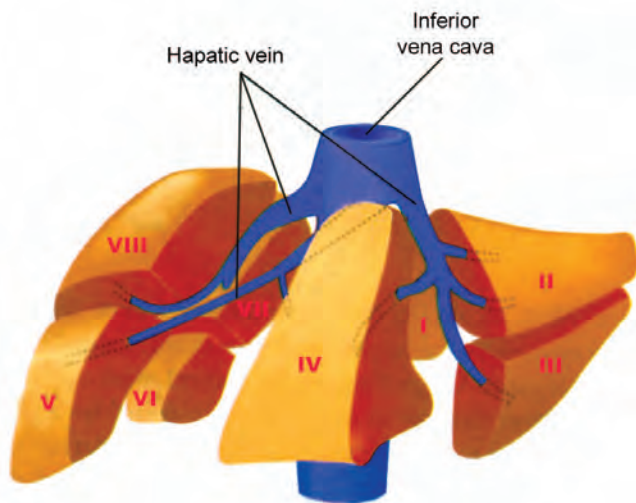

Fig. 5.23: Segmental anatomy of the liver

Liver Function Tests

Serum Enzymes

Serum enzymes are markers of hepatocellular injury and necrosis.

- a. *AST (SGOT) and ALT (SGPT)*: Serum transaminases are normally present in the blood (less than 40 units).

There are indicators of liver cell damage. Their serial determination reflects the clinical activity of the liver disease. In jaundiced patients, values greater than 300-400, suggest acute hepatocellular disease. Values more than 1000 units are observed in viral hepatitis, toxic or drug-induced liver disease, prolonged circulatory collapse. Lesser degree of elevation is found in mild viral hepatitis, diffuse and focal chronic liver disease (chronic active hepatitis, cirrhosis, secondaries). Sometimes serial estimations may be needed.

AST/ALT (SGOT/SGPT) ratio is most useful in detecting patients with alcoholic liver disease. AST/ALT ratio is greater than 2 in them due to decreased concentration of ALT in the hepatocyte cytosol. Serum of alcoholic patients are deficient in pyridoxal-5' phosphate, a co-enzyme necessary for the synthesis of transaminases especially ALT.

Uraemia depresses the aminotransferase levels. Higher degree of elevation of transaminases has a bad prognostic value.

- b. *Lactic dehydrogenase (LDH)*: LDH-5 corresponds to the liver but the elevation of LDH-1 is more sensitive for myocardial infarction and haemolysis.

Tests of Biosynthetic Function

- a. *Serum proteins*: Liver produces all the serum proteins (especially albumin, prothrombin, fibrinogen) except gamma globulin. A serum albumin value of less than 3 (normal 3.5-5.0 gm/dl) and serum globulins greater than 4 gm/dl (normal 2.0-3.5 gm/dl) suggest a chronic or progressive liver disease.

Increased globulin is as a result of increased stimulation of the peripheral reticuloendothelial compartment due to shunting of antigens past the liver and impaired clearance by Kupffer cells.

Deficiency or absence of alpha 1 globulin is found in alpha 1 antitrypsin deficiency. Increase in albumin value of 2-3 gm towards normal with treatment implies improvement in hepatic function and a more favourable prognosis.

Serum albumin has a long $t_{1/2}$ (18-20 days). Because of this slow turn over, serum albumin is not a good indicator of acute liver failure.

- b. *Prothrombin time (PT)*: The liver synthesises all the clotting factors except factor VIII. The one stage PT which reflects the activities of prothrombin, fibrinogen and factors V, VII and X is dependent on both hepatic synthesis of these factors and availability of vitamin K. Factor VII is the rate limiting factor in this pathway. Prolongation of PT (normal 11.5-12.5 seconds) by 2 seconds or more is considered abnormal.



Prolonged PT may also be present in congenital deficiencies of coagulation factors, consumption coagulopathy, drug intake and hypovitaminosis K. Prolongation of PT by more than 5-6 seconds heralds the onset of fulminant hepatic necrosis.

Prolongation of PT with no response to vitamin K therapy indicates poor long-term prognosis.

Prothrombin time is also prolonged in:

- i. Vitamin K malabsorption
- ii. Poor dietary intake of vitamin K
- iii. Antibiotic therapy (destruction of vitamin K producing commensals).

Tests of Cholestasis

Enzymes

- i. *Serum alkaline phosphatase* (normal value 3-13 KA units or 30-120 IU/L): This is derived from three sources
 1. Hepatobiliary system
 2. Bone
 3. Intestinal tract.

The hepatobiliary enzyme is differentiated from others by simultaneous estimation of 5' nucleotidase, gamma-glutamyl transpeptidase or leucine amino-peptidase. Values more than 3-10 times the normal level are suggestive of hepatobiliary diseases (extrahepatic and intrahepatic biliary obstruction, drug induced cholestasis, primary biliary cirrhosis).

Other causes of isolated alkaline phosphatase elevation:

1. Primary or metastatic tumour of liver or bone
2. Granulomatous liver disease
3. Hodgkin's disease
4. Non-Hodgkin's lymphoma
5. Liver abscess
6. CCF
7. Hyperthyroidism
8. Diabetes mellitus
9. Bone disease (Paget's disease, osteomalacia)
10. Partial extrahepatic bile duct obstruction
11. Sclerosing cholangitis
12. Pregnancy.

Persistent elevation of serum alkaline phosphatase > 30 KA units or 300 IU/L indicates obstructive jaundice.

- ii. *5'-Nucleotidase* (normal value is 0.3-3.2 Bodansky units or 2-17 U/L): This enzyme is primarily located in the liver. Serum values are elevated in hepatobiliary diseases. In screening for liver metastases, it has a high predictive value. It is done to confirm the hepatic origin of an increased alkaline phosphatase level in children

and pregnant women when there is co-existing bone disease.

iii. *Leucine aminopeptidase*: This is also useful in the diagnosis of biliary obstructive, space occupying and infiltrative diseases of the liver.

iv. *Gamma-glutamyl transpeptidase*: (Normal value—5-24 U/L) This enzyme is found in liver, pancreas and kidney. Elevated values are seen in liver, pancreas, cardiac, renal, pulmonary and biliary tract diseases. The values are elevated in alcoholic liver disease or in patients taking barbiturates or phenytoin. A GGT/AP value greater than 2.5 is suggestive of alcohol abuse. GGT is a potential marker of alcoholism.

GGT correlates with alkaline phosphatase levels and it is one of the most sensitive indicators of biliary tract disease.

MELD (Model for end stage liver disease) score:

- Designed to predict prognosis in liver disease and portal hypertension
- Assessing the need for liver transplantation
- It is calculated by using
 - i. Prothrombin time in the form of INR
 - ii. Serum bilirubin
 - iii. Serum creatinine

MELD formula:

$$3.8 \times \log(\text{total bilirubin mg/dL}) + 11.2 \times \log(\text{INR}) + 9.6 \log(\text{creatinine mg/dL})$$

Poor prognosis if the score is > 18-21

PELD score:

- It is used for children < 12 years
- It is calculated by using
 - i. Age and nutritional status
 - ii. Serum bilirubin
 - iii. Serum albumin
 - iv. PT in the form of INR

Maddrey index (Modified discriminant function):

$$4.6 (\text{Patient's PT} - \text{Control PT}) + \text{serum bilirubin mg/dL}$$

Poor prognosis if the score is > 32.

Serum Bilirubin

Serum bilirubin is measured by van den Bergh's diazo reaction. Unconjugated bilirubin requires the presence of alcohol for the diazo reaction and gives an indirect van den Bergh reaction. Conjugated bilirubin reacts directly without alcohol. Total serum bilirubin is measured with the diazo reaction carried out in alcohol, where both the conjugated and the unconjugated



bilirubin react with the reagent. The conjugated bilirubin is then measured from the diazo reaction carried out without alcohol. The difference represents the concentration of the unconjugated bilirubin.

Tests	Obstructive liver disease	Parenchymal liver disease
1. AST and ALT	Mild increase	Moderate to marked increase
2. Alkaline phosphatase	Markedly increased	May be mildly increased
3. Serum albumin	Normal	Decreased
4. Prothrombin time	Normal	Increased
5. Bilirubin	Normal or increased	Normal or increased
6. GGT	Increased	Normal or increased
7. 5' nucleotidase	Increased	Normal

Jaundice

Yellowish appearance of skin and mucous membranes resulting from an increase in bilirubin concentration in body fluids when serum bilirubin concentration exceeds 3 mg/dl. In latent jaundice, serum bilirubin level is between 1 and 2 mg/dl. Scleral tissue is rich in elastin and has a high affinity for bilirubin. Therefore, presence of scleral icterus is a highly sensitive index for detecting jaundice. It is best appreciated in natural light.

Yellowish discolouration of carotenaemia spares the sclera.

Metabolism of Bilirubin

One gm of haemoglobin yields 35 mg of bilirubin. Eighty per cent of the circulating bilirubin is derived from heme of haemoglobin which is in turn derived from senescent RBCs. Ten to twenty per cent of bilirubin comes from myoglobin, cytochromes and other haem containing proteins.

Haem is oxidised to biliverdin which is then reduced to bilirubin. Bilirubin is insoluble in aqueous solutions. In blood, bilirubin is bound to albumin at a 1:1 ratio. Unbound bilirubin can cross blood-brain barrier and causes kernicterus in neonatal hyperbilirubinaemia.

The processing of serum bilirubin by hepatocyte occurs in four steps namely hepatic uptake, cytosolic binding, conjugation and secretion.

The albumin bound bilirubin dissociates and bilirubin is subsequently transported into the hepatocyte through a saturable protein carrier.

In the hepatocyte, bilirubin binds to two cytosolic proteins ligandin and Z-protein. This limits the reflux of bilirubin back into the plasma.

The conjugation of bilirubin involves its esterification with glucuronic acid forming bilirubin monoglucuronide and diglucuronide, the reaction being catalysed by the enzyme UDP-glucuronyl transferase. Bilirubin is rendered water soluble by this mechanism and hence it is eliminated from the body in bile and urine.

Secretion of conjugated bilirubin into the bile from the hepatocyte is an active process against the concentration gradient involving a specific carrier. It is excreted in bile as a micellar complex with cholesterol, phospholipids and bile salts. It is later deconjugated and converted to urobilinogen by the colonic bacteria. By a process called enterohepatic circulation, a minor portion of bilirubin is reabsorbed. The rest is excreted in the stool (as stercobilinogen) and in urine (as urobilinogen).

Types

1. Hepatocellular jaundice (hepatic)
2. Haemolytic (prehepatic)
3. Obstructive (posthepatic).



Causes

Hepatocellular Jaundice

Viral Hepatitis—A, B, C, D, E, G and TT virus

Others—CMV, EBV, HSV, and Coxsackievirus

Toxoplasma, *Leptospira*, *Candida*, *Brucella*, mycobacteria and *Pneumocystis*.

Drugs

Halothane

Phenytoin

Carbamazepine

INH, rifampicin

Pyrazinamide

Methyldopa

Captopril, enalapril

Amitriptyline

Imipramine

Ibuprofen

Indomethacin

Ketoconazole

Fluconazole

Zidovudine

Paracetamol

Toxins

Alcohol

Carbon tetrachloride

Yellow phosphorus



Haemolytic Jaundice

- Intraerythrocytic*
 - Hereditary*
 - RBC membrane disorders (spherocytosis)
 - Disorders of glycolysis (enzyme deficiencies)
 - Haemoglobinopathies.
 - Acquired*
 - Dyserythropoietic states (B₁₂ and folate deficiency)
- Extraerythrocytic*
 - Autoimmune
 - Isoimmune
 - Alloimmune
 - Physical trauma
 - Prosthetic valve
 - Burns
 - Chemical trauma (dapsona)
 - Infections (malaria)
 - Toxic factors
 - Inflammations
 - Neoplasms.

Obstructive Jaundice

- Canalicular
 - Alcohol
 - Viral hepatitis
 - Cirrhosis
 - Lymphoma
 - Bacterial sepsis
 - Pregnancy
 - Idiopathic
 - Drugs
 - Erythromycin
 - Chlorpromazine
 - Chlorpropamide.
- Biliary
 - Calculi
 - Carcinoma pancreas
 - Tumours
 - Benign
 - Metastatic
 - Strictures
 - Biliary cirrhosis.

An Approach to Jaundice

If the physical examination shows

- Excoriation, consider cholestasis or high grade biliary obstruction
- Greenish hue (due to biliverdin) suggests long standing liver disease like biliary cirrhosis, sclerosing cholangitis, severe chronic hepatitis or long standing malignant obstruction

- Fever, epigastric or right hypochondrial tenderness suggests choledocholithiasis, cholangitis or cholestasis
- Painless jaundice suggests malignant biliary obstruction
- Enlarged tender liver suggests acute hepatitis, rapidly enlarging hepatic tumour
- Palpable gallbladder suggests distal biliary obstruction due to malignant tumour
- Splenomegaly suggests portal hypertension or haemolytic jaundice
- Palmar erythema, facial telangiectasia, Dupuytren's contracture are seen in chronic ethanol ingestion
- Evidence of hyperestrogenic state in cirrhosis (gynaecomastia, testicular atrophy, spider angiomas)
- Wasting or lymphadenopathy suggests malignancy
- Wasting and splenomegaly suggests pancreatic tumour obstructing the splenic vein or a widely metastatic lymphoma
- Look for increased JVP, KF ring, xanthomata
- Look for primaries from thyroid, GIT, breast, etc.
- Hyperbilirubinaemia
 - Predominantly unconjugated—> 85% of total bilirubin
 - Predominantly conjugated—> 15% of total bilirubin.

Congenital Jaundice

Crigler-Najjar Syndrome (Type I)

It is an autosomal recessive disorder with severe unconjugated hyperbilirubinaemia due to total absence of bilirubin uridine diphosphate—glucuronyltransferase (UDPGT). This results in kernicterus and may cause cerebral damage. This condition is uniformly fatal in the neonatal period. Bilirubin level ranges from 24-25 mg/dl. When patients survive up to 2nd decade, encephalopathy develops.



Treatment

There is no treatment.

Crigler-Najjar Syndrome (Type II)

It is an autosomal dominant disorder due to mild deficiency of UDPGT enzyme. This condition is compatible with normal life. Serum unconjugated bilirubin levels are in the range of 6-25 mg/dl. Kernicterus is uncommon.



Features	Haemolytic	Hepatocellular	Obstructive
1. Mechanism	Increased bilirubin production	Hepatocellular failure	Bile duct obstruction
2. Common cause	Haemolysis	Virus, drugs	Ca pancreas, gallstones
3. Mode of onset	Rapid	Gradual	Gradual
4. Symptoms	Anaemia, fever	Anorexia, nausea, vomiting, distaste to cigarette, coffee	Recurrent abdominal colic; fluctuating jaundice
5. Skin	Mild yellow tinged	Orange tinged	Greenish yellow
6. Urine	Colourless (absent bile pigments)	High coloured	Dark coloured (presence of bile pigments)
7. Urobilinogen	++	+	Absent
8. Pruritus	Nil	+	+++
9. Bradycardia	Nil	Rare	+
10. Motion	Normal	**Pale	Clay coloured
11. Serum bilirubin	Unconjugated	Both (conjugated and unconjugated)	Conjugated
12. AST and ALT	Normal	Grossly elevated	Slightly elevated
13. Serum alkaline phosphatase	Normal	Slightly raised	Grossly elevated
14. Coombs' test	Positive	-	-
Osmotic fragility	Increased	-	-
15. Spleen	++	+/-	-
16. Gallbladder	Not palpable	Not palpable	Palpable

*Urobilinogen is present normally in minimal quantities. In viral hepatitis, the quantum increases initially and disappears during the peak phase due to hepatocellular oedema and obstruction; it reappears during the recovery phase;

**Clay coloured stools are passed during the obstructive phase which reverts to normal colour in the recovery phase



Treatment

Phenobarbitone, UV light, liver transplant.

Gilbert's Syndrome

It is an autosomal dominant disorder. There is mild unconjugated hyperbilirubinaemia due to reduced glucuronyl transferase, mild haemolysis and defective bilirubin uptake. Patients have normal life expectancy. Serum bilirubin ranges from 1.3-3 mg/dl. Patients have normal liver serum tests and histology and there are no systemic symptoms.

Patients when placed on a diet of 300 Kcal without lipids for 24-48 hours, have an elevation of bilirubin by 100% or by 1.5 mg/dl.



Treatment

Occasionally phenobarbitone in a dose of 180 mg/day in divided doses for 2 weeks can be given to enhance the activity of glucuronyl transferase.

Dubin-Johnson Syndrome

It is an autosomal recessive disorder resulting in conjugated hyperbilirubinaemia secondary to a defect in canalicular transport of organic anions. The liver is darkly pigmented. Histologically, a yellow black

pigment is seen in lysosomes of hepatocytes. Liver may be slightly enlarged and tender. Serum bilirubin levels may rise up to 30 mg/dl. Urine coproporphyrin I is more than coproporphyrin III (the reverse of normal). Bromsulphthalein excretion is normal at 45 minutes and there is secondary rise at 120 minutes.

Patients have normal life expectancy and usually no treatment is required.

Rotor Syndrome

It is a conjugated hyperbilirubinaemia with non-pigmented liver. There is defective bilirubin uptake and reduced intrahepatic binding. Bilirubin level is usually less than 10 mg/dl. Here also, urine coproporphyrin I is more than III, but not to that extent seen in Dubin-Johnson syndrome.

Bromsulphthalein excretion is abnormal at 45 min and no secondary rise at 120 min.

Patients live normally and no treatment is required.

Viral Hepatitis

Viral hepatitis is caused by five main agents mainly hepatitis A, B, C, D and E viruses (Fig. 5.24).

Clinical Features (Fig. 5.25)

Headache, fever, malaise, anorexia, distaste for cigarettes and coffee, jaundice, upper abdominal pain due to



Differentiating Features of Hepatitis Viruses

Features	HAV	HBV	HCV	HDV	HEV	HGV
Genome	RNA	DNA	RNA	RNA	RNA	RNA
Family	Picornia	Hepadna	Flavi	Viroid	Calci	Flave
Incubation period (days)	15-45	30-180	15-150	30-180	15-60	14-35
Transmission	Faeco oral	Blood, saliva, sexually	Blood	Blood, sexually	Faeco oral	Percutaneous
Clinical						
Age group	Children, young adults	Young adults, babies, toddlers	Any age	Similar to HBV	Young adults	Unknown
Severity	Mild	Occ. severe	Moderate	Occ. severe	Mild	Unknown
Fulminant course	0.1%	0.1-1%	0.1%	5-20%	1-2%	Unknown
Progression to chronicity	None	Occasional (1-10%)	50%	Common	None	Yes
Carrier	None	0.1-30%	0.5-1%	Variable	None	Unknown
Carcinoma	No	+ esp. in neonatal infection	+	±	-	Unknown
Prognosis	Excellent	Worse with age, debility	Moderate	Acute—good; Chronic—poor	Good	Unknown
Prevention						
Active	Inactivated vaccine	Recombinant vaccine	No	Prevention of HBV infection	No	No
Passive	Immune serum globulin	Hyperimmune serum globulin; interferon 40% effective	No Interferon 50% effective	No	No	No

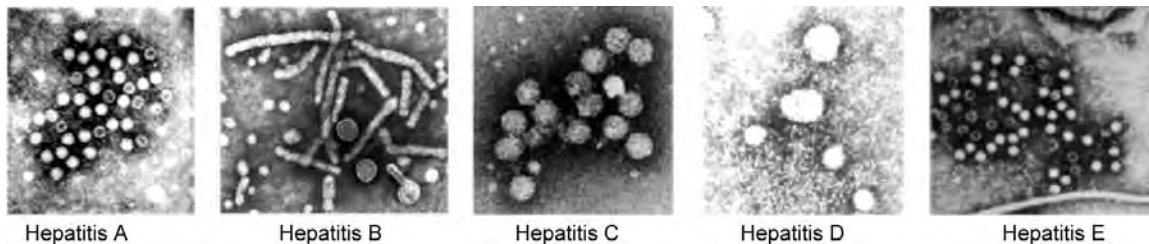

Fig. 5.24: Electron micrograph of viruses

stretching of peritoneum over enlarged liver; occasional lymphadenopathy and splenomegaly, arthralgia, skin rashes; mild illness may have an anicteric course.



Investigations

- Elevation of plasma aminotransferase activity (400–4000 U/L).
- Plasma bilirubin level (> 2.5 mg/dL up to 20 mg/dL). High bilirubin level of 20–40 mg/dL is common in sickle cell anaemia, G6PD deficiency due to superimposed haemolysis.
- Serum alkaline phosphatase level rarely exceeds 250 U/L.
- Prolongation of the prothrombin time (severe synthetic defect).
- Serological tests for HAV, HBV, HCV, CMV, EB viral infections.
 - Acute infection of HAV is marked by anti-HAV IgM in serum. Later IgG replaces IgM and persists for years conferring immunity.

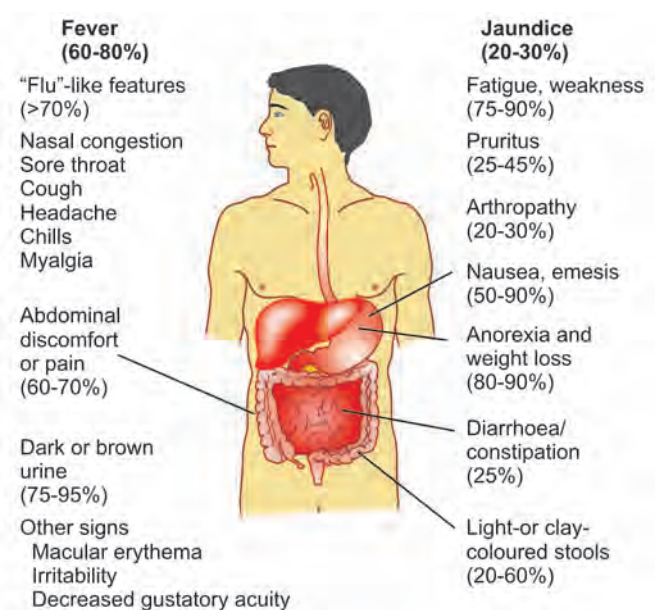

Fig. 5.25: Common symptoms in hepatitis

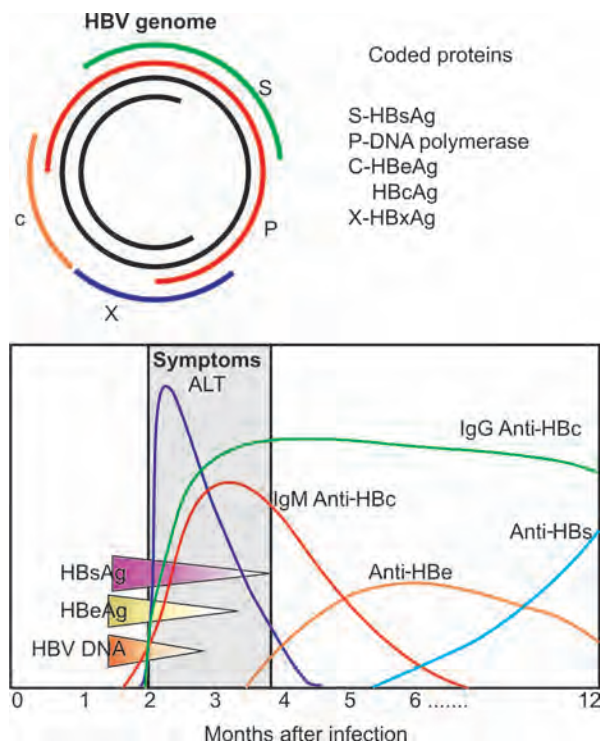
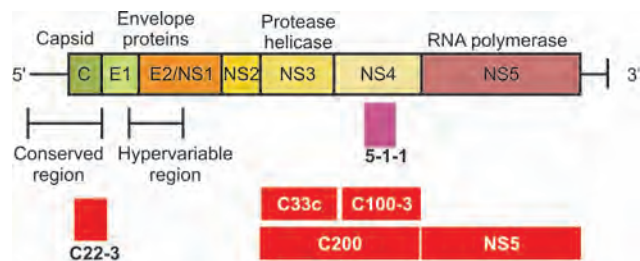

Fig. 5.26: HBV-antigens and antibodies

- b. HBsAg appears first and is a marker of active HBV infection, appearing before the onset of symptoms and declining over 3 to 6 months. HBe Ag, HBV-DNA and DNA polymerase are markers of active viral replication. Persistence of HBe Ag indicates continued viral replication and infectivity and progression to chronicity. IgM anti-HBc is usually the first antibody to appear followed shortly by anti-HBe. Appearance of anti-HBe suggests recovery (good prognosis). IgG anti-HBc slowly replaces the IgM over months. Anti HBs persists for years and confers protection against subsequent infection (Fig. 5.26).
- c. HDV can be identified by cDNA probe, radio-immunoassay for HDAg and IgM or IgG anti-HDV.
- d. Serological diagnosis of hepatitis C has advanced using newer generation of ELISA's which detect the infection earlier (Fig. 5.27).
 - i. First generation assays detect antibodies 1-3 months after the onset of hepatitis. (Antibodies against viral proteins C100-3)
 - ii. Second generation assays incorporate recombinant proteins from the nucleocapsid core region of virus (C22-3) and NS 3 region (C33c). These assays are more sensitive and detect anti-HCV 30-90 days earlier.



Laboratory findings in Acute hepatitis C progressing on to chronicity

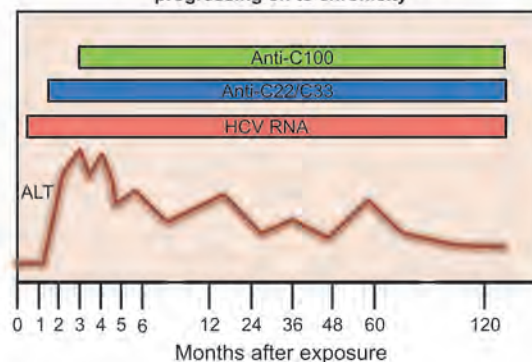

Fig. 5.27: Hepatitis C and its protein

- iii. Third generation immunoassay incorporates proteins from NS 5 region and may detect anti-HCV even earlier. Because of the non-specificity encountered in clinical samples tested for anti-HCV, a supplementary recombinant immunoblot assay is also used. The most sensitive indicator of infection is the presence of HCV RNA, which can be detected by amplification techniques within a few days of exposure.
6. Hypoglycaemia (nausea, vomiting, reduced CHO intake, poor hepatic glycogen) requiring hourly blood glucose estimation.



Complications

- Fulminant hepatic failure
- Cholestatic hepatitis
- Relapsing hepatitis (biochemical/clinical)
- Hyperbilirubinaemia (in Gilbert's syndrome)
- Renal failure
- Henoch-Schonlein purpura
- Chronic hepatitis
- Cirrhosis (HBV, HCV, HDV)
- Hepatocellular carcinoma (HBV, HCV)
- Aplastic anaemia, pancreatitis, myocarditis, atypical pneumonia, transverse myelitis and peripheral neuropathy are rare complications.



Diagnostic Approach in Patients Presenting with Acute Hepatitis

HBsAg	IgM anti-HAV	IgM anti-HBc	Anti-HCV	Interpretation
+	-	+	-	Acute hepatitis B
+	-	-	-	Chronic hepatitis B
+	+	-	-	Acute HAV + chronic hepatitis B
+	+	+	-	Acute hepatitis A + B
-	+	+	-	Acute hepatitis A + B (HBsAg ↓)
-	+	-	-	Acute hepatitis A
-	-	+	-	Acute HBV (HBsAg ↓)
-	-	-	+	Acute hepatitis C



Management

1. Bed rest
2. Nutritious diet, glucose and fruit drinks
3. Drugs are best avoided (sedatives, hypnotics, alcohol). Oral contraceptive pills can be resumed after clinical or biochemical recovery.
4. In severe acute hepatitis B treatment with Lamivudine at 100 mg/d orally may be tried.
5. In acute hepatitis C, antiviral therapy with interferon alpha 3 million units subcutaneously thrice weekly helps in reducing the rate of chronicity.
6. HAV and HEV do not induce chronic hepatitis or cirrhosis and specific treatment is not available. Give supportive treatment and liver transplantation in the event of FHF.
7. IFN- α (standard or pegylated) SC for 6 months in HCV acute infection. Ribavirin can be added.
6. Alarming elevated ESR—poor prognosis.
7. Recurring attacks of hypoglycaemia—poor prognosis.
8. Hepatorenal syndrome—poor prognosis.
9. Mortality is high in patients with other diseases like carcinoma, lymphoma or chronic liver disease.

Chronic Hepatitis (CH)

It is defined as biochemical or serologic evidence of continuing inflammatory hepatic disease for more than 6 months, with symptoms and without steady improvement. Histologically, CH can be divided into three forms.

Age and the virus type decide the incidence of chronic hepatitis. Hepatitis B—when infection occurs at birth, 90% develop chronic hepatitis whereas in adults only 1-5% develop chronic liver disease. In hepatitis C, 85-90% develop chronic hepatitis.

Older Classification

1. *Chronic persistent hepatitis*: It occurs typically with HBV, HCV, HBV-HDV infections.

The portal tracts are infiltrated with inflammatory cells (lymphocytes, macrophages, plasma cells). The infiltrate is limited to portal tracts and does not spill out into the hepatic parenchyma.

2. *Chronic active hepatitis*: It commonly occurs with HBV, HCV, HBV-HDV infections and other non-viral causes like drugs, metabolic disorders and autoimmune hepatitis.

Pathologically, it is characterised by piecemeal necrosis and fibrosis extending from the portal tracts into the hepatic parenchyma leading to cirrhosis. An exuberant portal inflammatory infiltrate spills out of portal tracts.

3. *Chronic lobular hepatitis*: It refers to lobular inflammation with spotty necrosis.

Newer Classification

The classification of chronic hepatitis is based on

1. Cause

Prognosis

Overall mortality is 0.5%.

Prognostic Indicators

1. HAV and HEV infections have good prognosis; Prognosis is variable in HBV, HCV and HDV infections. HBV and HCV infections are associated with chronicity; HBV and rarely HCV infection may lead to malignancy. HEV can cause a high mortality in pregnancy.
2. Enormous increase of AST/ALT indicate bad prognosis.
3. Bilirubin levels more than 20 mg/dL suggests bad prognosis. However, enormous rise more than 40 mg/dL is common in patients with associated G6PD deficiency or sickle cell anaemia.
4. If the liver is not enlarged, it indicates fulminant hepatic necrosis.
5. *Prothrombin time*: It is a very sensitive index. Prolongation of prothrombin time by 4–5 seconds indicates a bad prognosis.



- Histologic activity or grade
- Stage or degree of progression

Cause

HBV, HBV plus HDV, HCV, autoimmune hepatitis, drug induced chronic hepatitis and cryptogenic chronic hepatitis.

Grade

This is based on histological activity. The histologic features assessed are:

- Periportal necrosis including piecemeal necrosis and/or bridging necrosis.
- Intralobular necrosis
- Portal inflammation
- Fibrosis

This is known as histological activity index or Knodell-Ishak score.

Stage

This is based on the degree of fibrosis.

- Stage 0 - No fibrosis
 Stage 1 - Mild fibrosis
 Stage 2 - Moderate fibrosis
 Stage 3 - Severe fibrosis
 Stage 4 - Cirrhosis

Correlation between Earlier and Contemporary Classification of Chronic Hepatitis

Old classification	New classification	
	Grade	Stage
Chronic persistent	Minimal or mild	0 or 1
Chronic lobular	Mild or moderate	1
Chronic active	Mild, moderate or severe	1, 2 or 3



Causes of Chronic Hepatitis

- Viral (HBV, HCV, HDV)
- Drugs (alpha-methyl dopa, isoniazid)
- Alcoholic liver disease
- Non-alcoholic steatohepatitis
- Metabolic causes
 - Primary biliary cirrhosis
 - Sclerosing cholangitis
 - Alpha-1-antitrypsin deficiency
 - Wilson's disease
 - Haemochromatosis
- Autoimmune hepatitis
 - Type I (antiactin/lupoid)
 - Type II (anti-liver kidney microsomal)
 - Type III (anti-soluble liver antigen)
- Cryptogenic

Clinical and Lab Features of Chronic Hepatitis

Types	Diagnostic tests	Auto-antibodies	Therapy
Chronic hepatitis B	HBsAg, IgG anti-HBc, HBeAg, HBV DNA	-	Alpha interferon
Chronic hepatitis C	Anti-HCV, HCV RNA,	Anti-LKM ₁ *	Alpha interferon
Chronic hepatitis D	Anti-HDV, HDV RNA, HBsAg, IgG anti HBc	Anti-LKM ₃	? Alpha interferon
Auto-immune	ANA, anti-LKM ₁ ±, Hyperglobulinaemia	**ANA, Anti-LKM ₁	Prednisone, azathioprine
Drug associated	-	uncommon	withdraw drug
Cryptogenic	All negative	None	Prednisolone Azathioprine

* Liver kidney microsome

** Antinuclear antibody



Management of Chronic Hepatitis B

Algorithm for management (Fig. 5.28)

Drugs

Three parameters are taken into account for the management of chronic hepatitis B.

- HBeAg
 - HBV DNA level
 - ALT level
- Inactive non-replicative HBV carrier
 - Undetectable HBeAg
 - Normal ALT level
 - HBV DNA < 10⁴ copies/mL
 - No treatment is required
 - HBV DNA > 10⁵ copies/mL with either positive or negative HBe Ag
 - Treatment is essential if ALT is elevated
 - If ALT is not elevated, do a liver biopsy
 - No treatment if liver HP is normal
 - Treatment is essential if liver HP is abnormal

In case of cirrhosis (both compensated and de-compensated) treat with oral agents and IFN is contra-indicated. Do liver transplantation in case of ESLD.

The following are the goals of treatment for HBV:

 - Total clearance of HBV DNA
 - Normalisation of liver enzymes
 - HBeAg and HBsAg seroconversion (disappearance of antigens and appearance of antibodies)
 - Normalisation of liver histology

The following drugs are used to treat HBV infection:

 - IFN- α 2a and 2b—SC either 10 million units thrice weekly or 5 million units daily for 4-6 months or

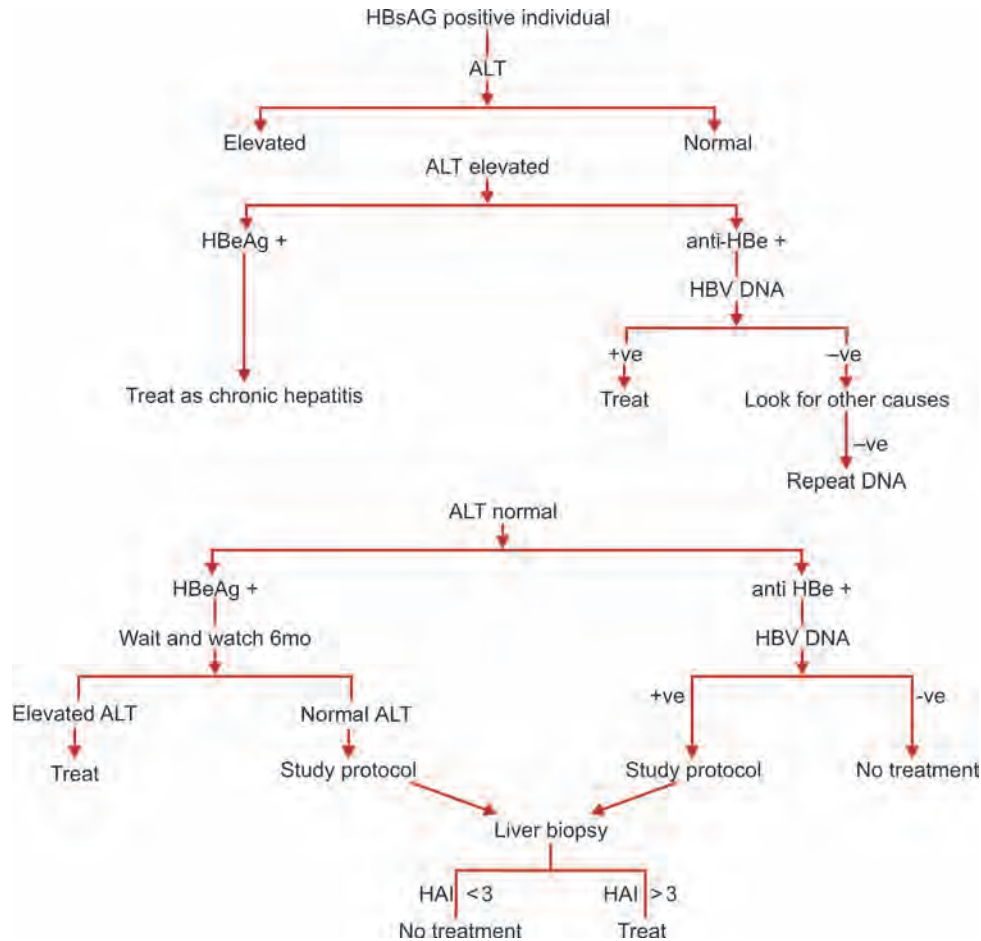

HAI—Histological activity index

Fig. 5.28: Algorithm, diagnosis and management of chronic hepatitis B

peginterferon α 2a 180 mcg weekly or 2b 100 mcg weekly for 48 weeks. Their use is contraindicated in de-compensated liver disease. IFN is pegylated by adding polyethylene glycol (PEG) and this prolongs the half-life and improves the bio-availability. Adverse effects of IFN therapy are fatigue, myalgia, arthralgia, fever, bone marrow suppression (neutropenia, thrombocytopenia, anaemia) depression, alopecia, and thyroiditis

- Lamivudine 100 mg daily orally for 48 weeks. Lamivudine resistance occurs early in HBV and HIV co-infected patients and treat them with adefovir and entecavir.
- Adefovir 10 mg daily orally for 48 weeks. It is also useful in lamivudine resistant cases and can safely be given in the presence of de-compensated liver disease. Dose modification is required in renal failure patients.
- Entecavir 0.5 mg orally and 1 mg orally in case of lamivudine resistance for 48 weeks.

- Telbivudine, clevudine, and entricitabine are under trial.
- Liver transplantation is indicated in FHF and ESLD. To prevent recurrence of HBV after liver replacement, combine lamivudine/adefovir/entecavir with hepatitis B immunoglobulin therapy.
- Since HDV is a co-infection with HBV, IFN α is the treatment of choice.



Management of Chronic Hepatitis C

Chronic HCV is Classified into 4 Groups

	Group I	Group II	Group III	Group IV
Anti-HCV	+	+	+	—
HCV RNA	—	+	+	+
ALT	NI	NI	Raised	NI
Management	No treatment	Under follow-up	IFN + Ribavirin	Liver biopsy

Drugs

HCV genotypes 1 and 4:

Peg IFN- α 2a 180 mcg SC weekly or Peg IFN- α 2b 1.5 mcg/kg SC weekly and ribavirin 1000-1200 mg/day orally for 48 weeks

HCV genotypes 2 and 3:

Peg IFN- α 2a 180 mcg SC weekly or Peg IFN- α 2b 1.5 mcg/kg SC weekly and ribavirin 800 mg/day orally for 24 weeks

- Antiviral therapy is not recommended in de-compensated cirrhosis and pregnancy (teratogenicity of ribavirin).
- If ribavirin is contraindicated, use only peg IFN.
- For HCV and HIV co-infected patients, duration of therapy is for 48 weeks irrespective of genotypes.
- Ribavirin is contraindicated in renal failure and in patients on haemodialysis.
- Adverse effects of ribavirin – haemolysis, teratogenicity, cough, dyspnoea, pneumonitis

NB: HCV has 6 genotypes. HCV 1 has poor response to therapy.

IgA is increased in alcoholic liver disease.

IgM is increased in primary biliary cirrhosis.

IgG is increased in chronic active hepatitis.

Prevention of Hepatitis**For HAV**

Anti-HAV immune globulin: When administered before exposure or during early incubation period, IG is effective in preventing clinically apparent type A hepatitis. Immunoglobulin attenuates infection but does not abort it. A dose of 0.02 ml/kg IM gives passive immunity for three months to those at risk (travellers, household contacts) and during incubation.

Hepatitis A vaccine: An inactivated protein vaccine (Harvix) grown in human diploid cells. *Dose:* 2 ml IM into the deltoid, two doses 2–4 weeks apart, if > 16 yr old. Immunity lasts for 1 year. If booster is given after 6 months, immunity lasts for 10 years.

For HBV

Pre-exposure prophylaxis (Health workers, doctors, paramedicals): Three IM injections (deltoid, not gluteal) of Hepatitis B vaccine is recommended at 0, 1 and 6 months. Pregnancy is not a contraindication to vaccination.

Vaccines available are

1. Recombivax-HB (10 μ g HBsAg)
2. Engerix-B (20 μ g HBsAg).

Dosage

Recombivax-HB

- 2.5 μ g HBs for children < 11 yrs of age of HBsAg negative mothers
- 5 μ g for infants of HBsAg positive mothers and for children and adolescent 11–19 years of age
- 10 μ g for immunocompetent adults
- 40 μ g for dialysis patients and immunosuppressed.

Engerix-B

- 10 μ g for children aged 10 and under
- 20 μ g for immunocompetent children > 10 yr of age and adults
- 40 μ g for dialysis patients and for immunosuppressed.

Post-exposure prophylaxis: A combination of vaccine and HBIG are recommended.

Perinatal exposure of infants born to HBsAg positive mothers: A single dose of HBIG, 0.5 ml IM in the thigh immediately after birth + complete course of 3 injections starting within 12 hours of life.

Accidental needle stick, other mucosal penetration: A single IM dose of HBIG, 0.06 ml/kg soon after exposure + full course of vaccination within first week of exposure.

Sexual contact: A single IM dose of HBIG (0.06 ml/kg) within 2 weeks + complete course of vaccination.

It gives a protection of 80–90% for five years. Booster immunization is recommended for haemodialysis patients especially when anti-HBs levels fall < 10 mIU/ml.

Autoimmune Hepatitis (AIH)

AIH is a chronic inflammation of the liver of unknown aetiology associated with circulating auto-antibodies and hypergammaglobulinaemia.

**Clinical Features**

It occurs most often in women (10-30 years and late middle age). The common symptoms are fever, fatigue, intermittent jaundice, weight loss, and pruritus. They may present with urticaria, hepato-splenomegaly and lymphadenopathy.

Patients may present with FHF or asymptomatic elevation of ALT or with signs of cirrhosis liver.



Extrahepatic manifestations may be found in 30-50 % of cases and that include autoimmune thyroiditis and haemolytic anaemia, grave's disease, ulcerative colitis, and rheumatoid arthritis.



Investigations

- Elevated levels of serum aminotransferases (AST and ALT)
- Circulating autoantibodies (antinuclear antibody, anti-smooth muscle antibody, and liver-kidney microsomal antibody)
- Hypergammaglobulinaemia
- Liver biopsy—piecemeal necrosis or interface hepatitis.



Treatment

- Prednisone alone 40-60 mg/day
- Prednisone and azathioprine 1-2 mg/kg/day till remission occurs (> 1-2 years)
- Relapse (20-30% of cases) requires retreatment
- Life-long low dose therapy in some cases
- Salvage therapy in refractory cases – Cyclosporine, tacrolimus, mycophenolate mofetil
- Liver transplantation for ESLD.

Polycystic Liver Disease (Fig. 5.29)

- It is genetically linked to chromosome 19
- 50% of cases are often associated with autosomal dominant polycystic kidney disease
- They are thin walled and contain clear or brown fluid due to altered blood
- Cyst may vary in size from pin's head to a child's head

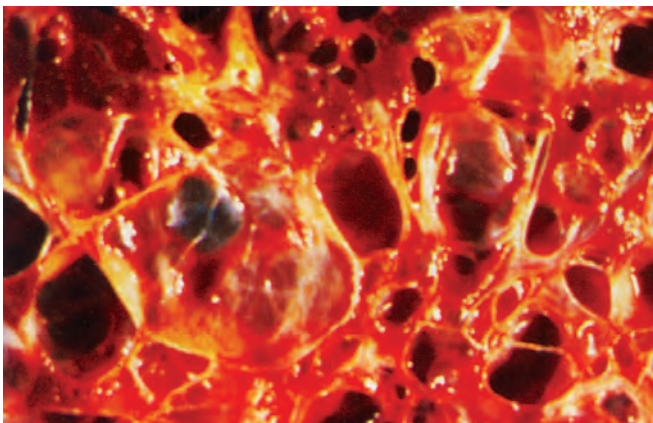

Fig. 5.29: Polycystic disease—liver

- They never contain bile (No continuity with biliary tract)
- Complications – Haemorrhage, infection and very rarely carcinoma.
- Surgery is very rarely necessary.

Liver Abscess

Liver is the organ commonly involved in the development of abscesses. It may be solitary or multiple. Amoebic abscesses are single and pyogenic abscesses are multiple. In developing countries, abscesses are due to parasitic infection (amoebic, echinococcal, other protozoal or helminthic organisms). In developed countries, abscesses are due to bacterial infection.



Causes

1. Organisms reaching the liver via the portal vein (amoebiasis, appendicitis, actinomycosis of right iliac fossa).
2. Via arterial supply (septicaemia, pyaemia, facio-cervical actinomycosis, infected hydatid cyst).
3. Direct invasion from adjacent structures (subphrenic abscess, empyema).
4. Via biliary tree (ascending cholangitis due to stone, strictures).
5. Direct penetrating injury.



Clinical Features

Patient may present with fever, pain, tenderness in right upper quadrant, chills, anorexia, nausea, vomiting or jaundice, 50% of patients have hepatomegaly. It may present as FUO, especially in the elderly.



Investigations

1. Elevation of serum alkaline phosphatase (in 90%).
2. Elevation of serum bilirubin (in 50%).
3. Elevation of serum transaminases (in 45%).
4. Leucocytosis, normochromic normocytic anaemia, hypoalbuminaemia.
5. *Chest X-ray occasionally shows elevation of right hemidiaphragm, right basal infiltration or a right pleural effusion.
6. Imaging studies—USG, CT scan (Fig. 5.30), gallium or indium labelled WBC scan, MRI.

Note: *Elevation of right hemidiaphragm is common in amoebic liver abscess (Fig. 5.31).

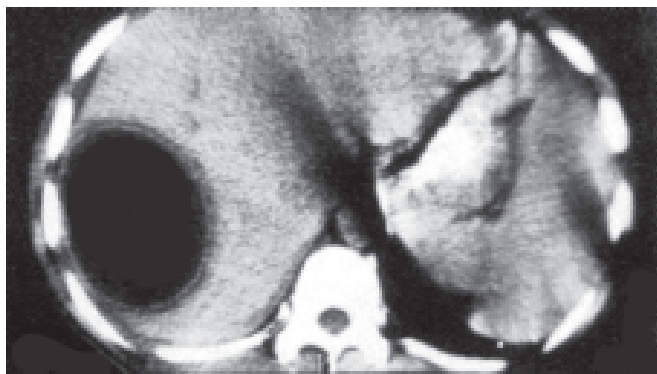

Fig. 5.30: CT scan—hepatic abscess



Fig. 5.31: X-ray—amoebic liver abscess with elevated right hemidiaphragm and minimal pleural effusion



Management of Pyogenic Abscess

1. Antimicrobials according to aetiology. In haematogenous spread of infection, *S. aureus*, *Streptococcus milleri* are involved. In abscesses following pelvic/intraperitoneal source of infection, anaerobes or mixed flora are common. Abscesses due to *E. histolytica*, *Candida* are seen in immunocompromised patients.
2. Drainage of abscess using either percutaneous or pigtail catheter can be done. Failure of this procedure suggests
 - a. Multiple abscesses
 - b. Viscous abscess contents
 - c. Associated diseases.

If there is a lack of response to percutaneous drainage in 4 to 7 days, primary surgical intervention is needed.

Amoebic Abscess

Symptoms and signs may be non-specific. Common in alcoholics. Most common site is postero-superior quadrant of right lobe of liver. Pus is chocolate coloured and anchovy sauce like (broken down liver cells, leucocytes, RBCs) or green in colour if admixed with bile.



Complications

1. Sterile pleural effusions
2. Contiguous spread from liver
3. Frank rupture into pleural space
4. Hepatobronchial fistula (good prognosis)
5. Rupture into peritoneum, pericardium (grave prognosis).

Rupture can occur during medical therapy and may require surgical drainage.



Treatment

1. Water sanitation; take fruits and vegetables after washing and after removing the skin. Cysts in water are disinfected by iodination.
2. *Drugs:*
Metronidazole—800 mg orally or 500 mg IV tid for 10 days
or
Tinidazole—2 gm orally OD for 3 days
or
Ornidazole—2 gm orally.
These drugs are given along with a luminal agent (paromomycin 500 mg tid for 10 days or diloxanide furoate 500 mg tid for 10 days).
3. *Aspiration*
 - a. To rule out pyogenic abscesses especially if they are multiple
 - b. Failure to respond clinically in 3–5 days
 - c. Threat of imminent rupture
 - d. Left lobe abscess to prevent rupture into pericardium or peritoneum
 - e. Large abscesses of more than 10 cm in size
4. Surgery in cases of bowel perforation and rupture of abscess into pericardium.

Steatosis

Microvesicular steatosis:

1. Acute fatty liver of pregnancy
2. Reye's syndrome (aspirin toxicity in children)



3. Drugs
 - Sodium valproate
 - Tetracyclines
 - Salicylates
 - Yellow phosphorus
4. Toxins – bacillus cereus

Macrovesicular steatosis:

1. Centripetal obesity—DM (type 2), Insulin resistance, hyperinsulinaemia
2. Drugs—glucocorticoids, oestrogen, tamoxifen, amiodarone, methotrexate
3. Nutritional—starvation, protein deficiency (Kwashiorkor), choline deficiency
4. Liver disease
 - Wilson's disease, chronic hepatitis C (genotype 3)
 - Indian childhood cirrhosis, jejunoileal bypass
 - Alcoholic liver disease (initially micro and then to macrovesicular)

Non-Alcoholic Fatty Liver Disease

It is a syndrome that encompasses several clinical entities that range from simple steatosis to non-alcoholic steatohepatitis (NASH). 1-2% of simple steatosis patients have the risk of developing cirrhosis over a period of 20 years.

NASH is defined as steatosis with hepatocellular ballooning and lobular inflammation. It may end up with fibrosis and end stage liver disease in the absence of significant alcohol consumption (Figs 5.32A and B).

- 25% progress to cirrhosis in 10-15 years
- 70% of cases of cryptogenic cirrhosis have NASH as the underlying aetiology

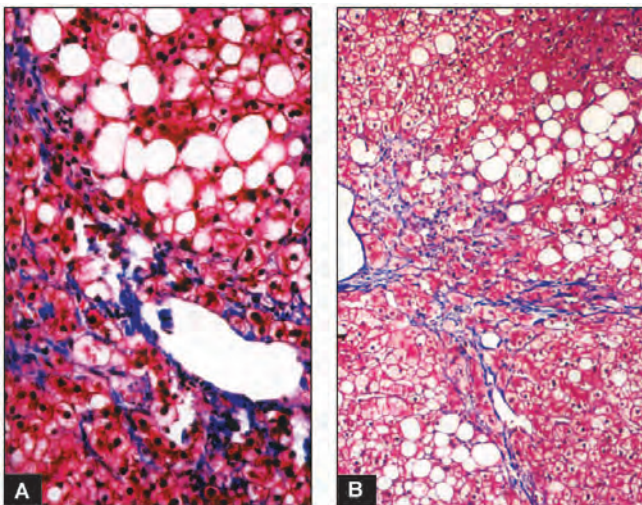

Figs 5.32A and B: (A) Non-alcoholic steatohepatitis (NASH)—Early stage (B) Late stage—chickenwire fibrosis

- NASH is associated with insulin resistance and metabolic syndrome (DM, HTN, dyslipidaemia and obesity)
- Abnormal ferritin values are seen in 50% of NASH patients and the increased level may be a marker of insulin resistance.

Diagnosis

- Elevated aminotransferases (ALT > AST)
- Liver biopsy showing
 - i. Macrovesicular steatosis
 - ii. Mallory hyaline changes
 - iii. Perivenular and perisinusoidal fibrosis



Treatment

- Correct obesity by diet control and exercise
- Use thiozolidinediones to improve insulin sensitivity in DM
- Treat hyperlipidaemia with statins
- Liver transplantation for end stage liver disease

Cirrhosis of Liver

Cirrhosis is defined as an irreversible chronic injury of the hepatic parenchyma and include extensive fibrosis in association with the formation of regenerative nodules.

Nodules may vary from < 3 mm (micronodules) to several cm in size (macronodules).



Causes of Cirrhosis of Liver

1. Viral hepatitis (HBV ± Delta virus, HCV)
2. Alcohol
3. Non-alcoholic steato-hepatitis (NASH)
4. Metabolic
 - Haemochromatosis
 - Wilson's disease
 - α_1 antitrypsin deficiency
 - Diabetes mellitus
 - Galactosaemia
 - Tyrosinosis
 - Fanconi's syndrome
 - Hereditary fructose intolerance
 - Type IV glycogen storage disease
5. Prolonged cholecystitis—intra- and extrahepatic
6. Hepatic venous outflow obstruction
 - Veno-occlusive disease,
 - Budd-Chiari syndrome
 - Constrictive pericarditis

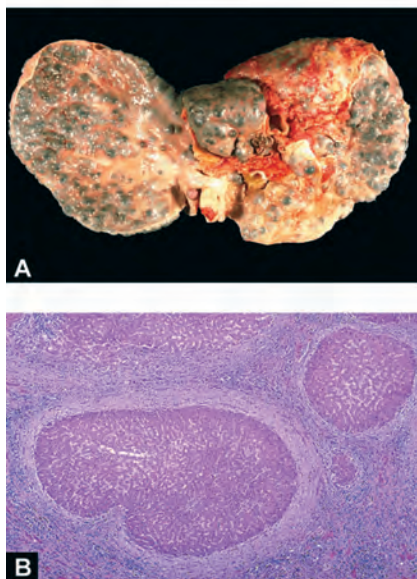

Figs 5.33A and B: (A) Macronodular cirrhosis
(B) Micronodular cirrhosis

7. Disturbed immunity (lupoid hepatitis)
8. Toxins and drugs: Methotrexate and amiodarone
9. Intestinal bypass, gastroplasty
10. Indian childhood cirrhosis/malnutrition
11. Syphilis in neonates
12. Cystic fibrosis
13. Schistosomiasis
14. Cardiac failure (chronic right sided heart failure, tricuspid insufficiency)
15. Cryptogenic—unknown aetiology.

Morphological Classification (Figs 5.33A and B)

- a. Micronodular cirrhosis (Laennec's cirrhosis)
- b. Macronodular cirrhosis (postnecrotic or viral)
- c. Mixed type.

Aetiopathological Classification

- a. Alcoholic cirrhosis or Laennec's cirrhosis (60–70%)
- b. Postnecrotic or postviral cirrhosis (10%)
- c. Biliary cirrhosis (5–10%)
- d. Cardiac cirrhosis
- e. Metabolic cirrhosis (Rare)
- f. Miscellaneous.

Alcoholic Cirrhosis

It is characterised by diffuse fine scarring, fairly uniform loss of liver cells and small regenerative nodules.

Aetiopathogenesis

Safe weekly limits of alcohol

In males 21 units

In females 14 units

(1 unit = 10 gm of alcohol, 30 cc of whisky, 100 cc of wine, 250 cc of beer).

Cirrhosis is 6 times greater when consumption is 40–60 gm/day, roughly double the safety limit. Cirrhotic dose—180 gm of ethanol/day for 25 years, i.e. 6 times the safety limit.

The early insult to the liver includes hepatocyte degeneration and necrosis. Damaged hepatocytes contain mallory bodies. The degeneration causes fibrosis followed by regeneration resulting in the formation of nodules.



Clinical Features

Anorexia, weight loss, muscle wasting, jaundice and fatigue are common symptoms. Signs of liver cell failure, parotid and lacrimal gland enlargement and clubbing of fingers occur. A firm nodular liver either enlarged, normal or decreased in size may be present. There may be mild to moderate splenomegaly. Later signs of portal hypertension and hepatic coma develop.

Enlarged Liver in Cirrhosis

1. Early stage of cirrhosis (especially in alcoholic)
2. Primary biliary cirrhosis
3. Primary sclerosing cholangitis
4. Haemochromatosis
5. Wilson's disease

Pathophysiologic Consequences of Cirrhosis

1. Alteration of hepatic blood flow causing portal hypertension
2. Reduction in functional cell mass resulting in:
 - a. Decreased synthesis of albumin, coagulation factors and other proteins
 - b. Decreased detoxification.

Importance of Platelet count

Progressive decline in platelet count is an important marker and the first clue for the evolution of cirrhosis in a patient with chronic liver disease.



Investigations

1. AST/ALT (SGOT/SGPT) ratio is greater than 2 in alcoholic patients due to severely depressed ALT by alcohol.



Elevation of AST more than ALT is also seen in Wilson's disease and established cirrhosis secondary to HBV infection (In contrast to ALT > AST in chronic hepatitis B).

2. Prolonged serum prothrombin time due to reduced synthesis of vitamin K dependent clotting factors.
3. Serum albumin is depressed and serum globulins are increased due to impaired protein synthesis by liver.
4. Leucopenia and thrombocytopenia due to hypersplenism and due to the effect of alcohol on the bone marrow.
5. Glucose intolerance (due to insulin resistance).
6. Elevated ammonia level in hepatic encephalopathy.
7. Other abnormalities include hypomagnesaemia, hypophosphataemia, hyponatraemia, hypokalaemia and respiratory alkalosis.
8. Ultrasonography to find liver size and obstructive disorders of hepatobiliary tree.
9. Liver biopsy to confirm the diagnosis.



Treatment

Treatment is purely symptomatic.

1. Alcohol should be forbidden.
2. Diet enriched with proteins and amino acids.
3. Drugs must be administered with caution as almost all the drugs undergo metabolism through liver.

Postnecrotic Cirrhosis

It is characterised by extensive loss of liver cells, stromal collapse and fibrosis resulting in broad bands of connective tissue containing the remains of portal triads and irregular nodules of regenerating hepatocytes.

Aetiology

1. Hepatitis B, C viral infections (especially among homosexuals and intravenous drug abusers).
2. Chronic active hepatitis.
3. Drugs and toxins (arsenicals, INH, methotrexate, methyl dopa).
4. Alcoholic and primary biliary cirrhosis leads to post-necrotic cirrhosis in later stages.

Pathogenesis

The liver is shrunken, distorted in shape. Nodules of variable size are seen.

Cryptogenic Cirrhosis

The diagnosis of cryptogenic cirrhosis is reserved for those patients in whom no aetiology can be demon-

strated. Clinical features, diagnosis and treatment are almost similar to alcoholic cirrhosis.

Biliary Cirrhosis

There are two types of biliary cirrhosis

1. Primary biliary cirrhosis
2. Secondary biliary cirrhosis.

Primary biliary cirrhosis is characterised by chronic inflammation and fibrous obliteration of intrahepatic bile ducts. Secondary biliary cirrhosis is characterised by partial or complete obstruction of larger extrahepatic bile ducts.

Aetiology and Pathogenesis of Primary Biliary Cirrhosis

Aetiology unknown. Commonly seen in women of 30–50 years of age.

Primary biliary cirrhosis is associated with autoimmune diseases like CRST syndrome (calcinosis, Raynaud's phenomenon, sclerodactyly, telangiectasia), sicca syndrome, autoimmune thyroiditis. The autoantigen commonly involved is 74-kDa E₂ component of pyruvate dehydrogenase complex.

An increased level of IgG antimitochondrial antibody and increased levels of serum IgM, cryoproteins consisting of immune complexes are seen in 80–90% of patients. Lymphocytes are prominent in the portal regions and surround damaged bile ducts.

Secondary biliary cirrhosis is caused by postoperative strictures and gallstones.



Clinical Features

Patients may be asymptomatic. Earliest symptom is pruritus. Other symptoms include jaundice, fatigue, melanosia, steatorrhoea, malabsorption of fat soluble vitamins, elevation of serum lipids resulting in xanthelasma and xanthomas. Later, signs of hepatocellular failure and portal hypertension develop. Fever and right upper quadrant pain (cholangitis/biliary colic) may occur in secondary biliary cirrhosis (Fig. 5.34).



Investigations

1. Two- to five-fold increase in serum alkaline phosphatase and elevation of serum 5' nucleotidase are seen.
2. There may be an increased titre of more than 1 : 40 of antimitochondrial antibody. It is a specific and sensitive test.

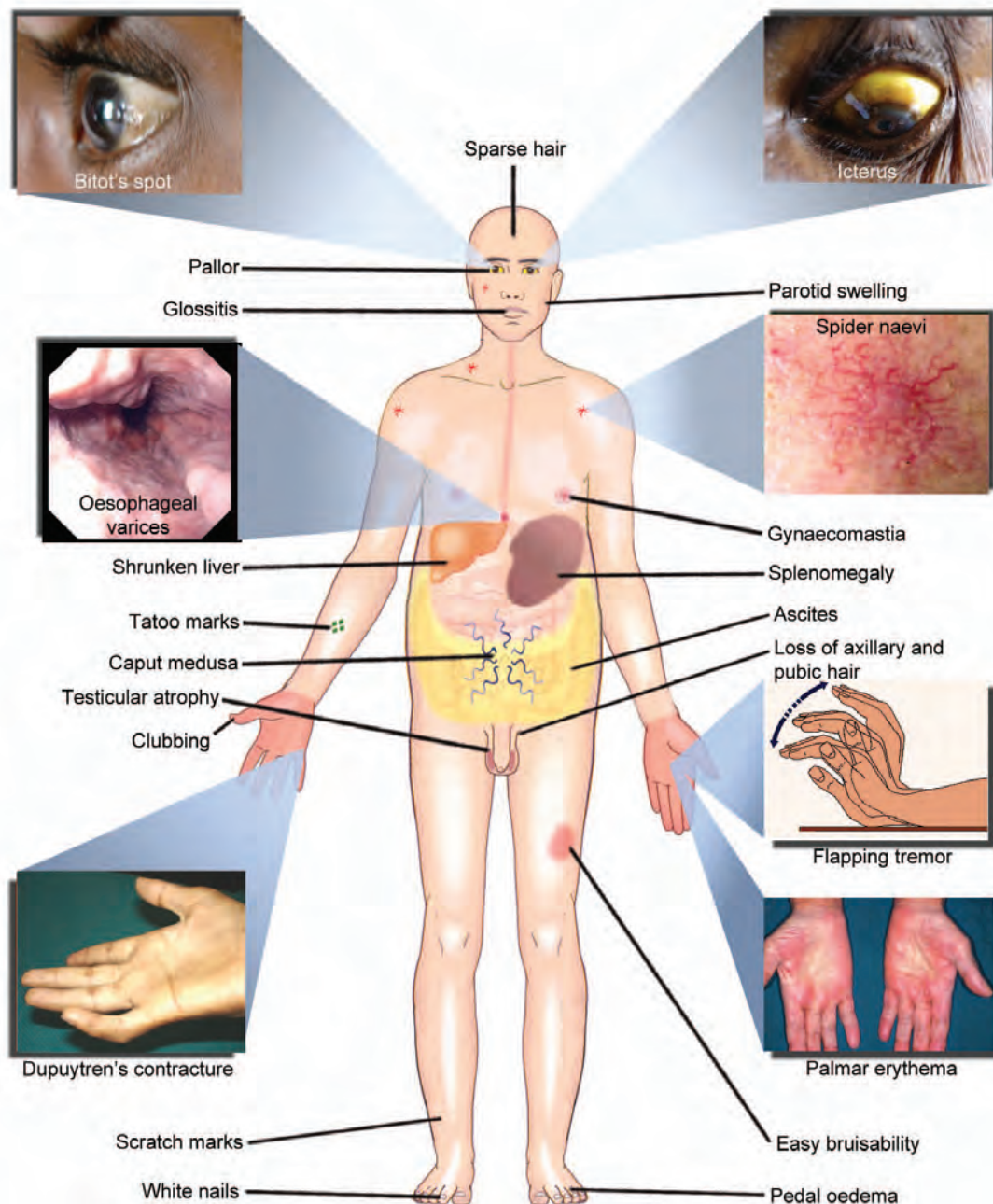

Fig. 5.34: Clinical manifestations of cirrhosis

3. Elevated serum cholesterol and lipoproteins are seen.
4. Raised serum bilirubin in terminal stages.
5. Liver biopsy

Stage 1 Necrotising inflammatory process (acute and chronic inflammatory cells) of the portal triads with destruction of medium and small sized bile ducts

Stage 2 Ductule proliferation

Stage 3 Expansion of periportal fibrosis due to scarring.

Stage 4 Micro or macronodular cirrhosis.

Treatment

- No specific therapy for primary biliary cirrhosis.
1. Colchicine in the dose of 0.6 mg orally twice daily.



2. Methotrexate in a low dose and cyclosporine are used to slow the progression or arrest the disease.
3. Ursodiol 13 to 15 mg/kg/day is shown to produce symptomatic improvement and improvement in serum biochemical parameters.
4. Symptomatic treatment includes antipruritic agents and cholestyramine 8 to 12 gm/day for pruritus and hypercholesterolaemia.
5. Low fat diet for steatorrhea.
6. Vitamin A, D, K supplements parenterally for correction of deficiencies.
7. Secondary biliary cirrhosis is treated by surgical means or endoscopic relief of the obstruction.

Cardiac Cirrhosis

Aetiology

Prolonged severe right sided congestive heart failure may lead to chronic liver injury and cardiac cirrhosis.

Pathogenesis

In chronic right heart failure, retrograde transmission of elevated venous pressure leads to congestion of liver. Hepatic sinusoids become dilated and engorged with blood. Macroscopically the liver is referred to as 'nutmeg liver'.



Clinical Features

Liver is enlarged, firm, non-tender and non-pulsatile in spite of TR. Signs and symptoms of right heart failure are seen (Fig. 5.34).



Investigations

Mild elevation of serum bilirubin and serum AST levels. Investigations for chronic heart disease (X-ray, ECG, Echo).



Treatment

Treat the underlying cardiovascular disorder.



Complications of Cirrhosis

1. Portal hypertension
2. Ascites
3. Hepatic encephalopathy
4. Spontaneous bacterial peritonitis
5. Hepatorenal syndrome
6. Hepatocellular carcinoma
7. Coagulopathy
8. Hepato-pulmonary syndrome
9. Malnutrition
10. Bone disorders—osteopenia, osteoporosis, osteomalacia
11. Haematological—anaemia, neutropenia, thrombocytopenia, haemolysis.

Portal Hypertension

Normal pressure in the portal vein is 10–15 cm saline or 7–10 mm Hg.

Portal hypertension is present when the sustained elevation of portal pressure is > 10 mm of Hg but the risk of variceal bleeding is greater only when it is > 30 cm saline or > 12 mm of Hg.

Classification

The obstruction to portal blood flow can occur at three levels

1. Portal vein (prehepatic)
2. Intrahepatic (presinusoidal, sinusoidal, postsinusoidal)
3. Hepatic veins (posthepatic).



Clinical Features

Patients may present with any of the complications of portal hypertension namely

1. Collateral circulation and varices
2. Ascites
3. Congestive splenomegaly, hypersplenism
4. Encephalopathy
5. Congestive gastropathy.

Prehepatic	Intrahepatic			Posthepatic
	Presinusoidal	Sinusoidal	Postsinusoidal	
a. Portal vein thrombosis	a. Schistosomiasis	a. Cirrhosis	a. Alcoholic hepatitis	a. Inferior vena caval web
b. Splenic arteriovenous fistula	b. Sarcoidosis	b. Primary biliary cirrhosis	b. Veno-occlusive disease	b. Tricuspid insufficiency
c. Constriction of the veins	c. Metastatic carcinoma	c. Cryptogenic; alcohol-induced cirrhosis	c. Hepatic vein thrombosis	c. Pericarditis
	d. Congenital hepatic fibrosis			

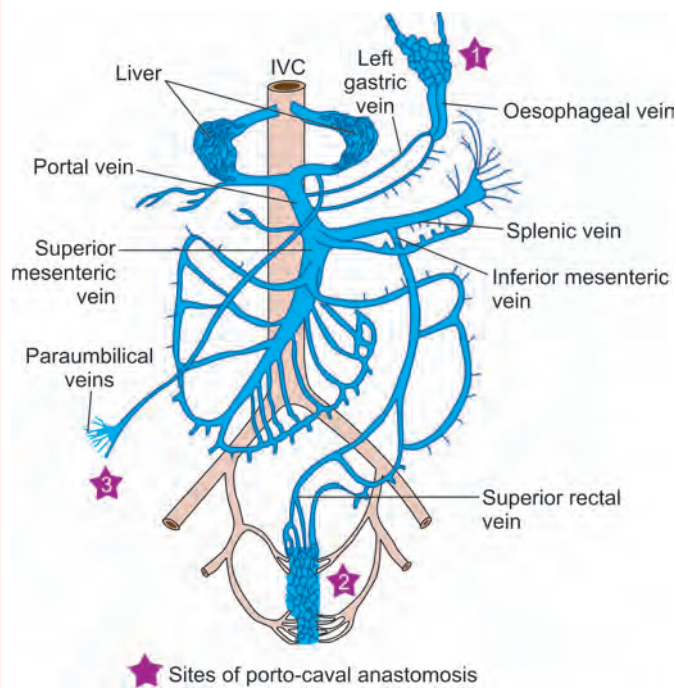

Fig. 5.35: Portal venous system

Collateral Circulation (Varices)

Extensive portal-systemic venous communications develop in order to decompress the high-pressure portal venous system. Maintenance of portal hypertension after the collaterals are formed, is attributed to a resultant increase in splanchnic blood flow.

Major Sites of Collaterals (Fig. 5.35)

1. Oesophageal and gastric varices (left gastric vein and short gastric vein join with intercostal, diaphragmatic, oesophageal and azygos veins of the caval system).
2. Hemorrhoids (Superior haemorrhoidal vein of the portal system to middle and inferior haemorrhoidal veins of the caval system).
3. Caput medusae (remnants of the umbilical circulation of the foetus present in the falciform ligament may form a large paraumbilical vein).
4. Other sites of anastomoses are retroperitoneal veins, lumbar veins, omental veins and veins over bare area of the liver.



Investigations

1. *Fibreoptic oesophagoscopy*: Shows the presence of oesophageal and gastric varices.
2. Measurement of portal venous pressure by either percutaneous transhepatic skinny needle catheteri-

sation or through transjugular cannulation of the hepatic veins. Wedged hepatic venous pressure is high in sinusoidal and postsinusoidal portal hypertension.

3. *USG abdomen*: Features of portal hypertension such as splenomegaly, collaterals, cause of liver disease (occasionally) or portal vein thrombosis can be detected. Portal vein size can be assessed. (Normal portal vein size is 1 cm; when portal vein size is 2 cm, it is said to be dilated; when it is more than 3 cm, it is said to be aneurysmally dilated).
4. *Portal venogram*: Site and the cause of portal venous obstruction can be detected and is also performed prior to surgical therapy.



Complications

- Variceal bleeding
- Congestive gastropathy
- Hypersplenism
- Ascites
- Renal failure
- Hepatic encephalopathy.



Management

1. Beta-blockers like propranolol or nadolol can be used due to their vasodilatory effects on both the splanchnic arterial bed and the portal venous system in combination with reduced cardiac output. Propranolol prevents recurrent bleeding from severe portosystemic gastropathy in cirrhotic patients.
2. Treatment of alcoholic hepatitis, chronic active hepatitis and other diseases results in fall in portal venous pressure and reduction in variceal size.

Variceal Bleeding

Variceal bleeding occurs when portal venous pressure is more than 12 mm Hg. Mostly bleeding arises from oesophageal varices within 3–5 cm of the oesophago-gastric junction or from gastric varices.

Factors Predisposing to Bleeding

- Large varices
- Endoscopic variceal stigma (red spots, red stripes)
- High portal pressure
- Liver failure
- Drugs (NSAIDs)
- Tense ascites.

Usually there are no precipitating factors.



Modified Child's Classification

Variables	Scores		
	1	2	3
Encephalopathy (degree)	Nil	Slight-moderate	Moderate-severe
Ascites (degree)	Nil	Slight	Moderate-severe
Bilirubin (mg/dl)	< 2	2–3	> 3
Albumin (gm/dl)	≥ 3.5	2.8–3.4	< 2.8
Prothrombin index (%)	> 70	40–70	< 40
Prothrombin time (in seconds)	≤ 14	15–17	≥ 18

Scores are summed to determine Child's class.
 Class A 5–7 (suitable for surgery)
 Class B 7–10 (marginal risk for surgery)
 Class C more than 10 (unsuitable for surgery).



Clinical Features

Symptoms and signs of shock (tachycardia, systolic BP less than 90 mmHg, urine output less than 30 ml/hour).



Management

Variceal bleeding is a life-threatening emergency.

All patients with cirrhosis and GI bleed should receive broad spectrum antibiotics such as ciprofloxacin.

1. Replacement of blood, coagulation factors by fresh, frozen plasma (in coagulopathy).
2. Monitor CVP, PCWP, urine output and mental status.

Treatment of sequelae of portal hypertension especially variceal bleeding is titrated to reduce the hepatic venous pressure gradient (HVPG) to < 12 mm of Hg or 20% from the baseline (HVPG = Wedged hepatic venous pressure – Free hepatic venous pressure).

When the HVPG is not feasible or available, reduction of resting pulse rate by 25% -using β -blockers is reasonable.

3. **Vasoconstrictors**

a. **Vasopressin:** 0.1–0.5 units/minute for 4–12 hours and subsequently reduce the dose and continue up to 48 hours. It reduces blood flow in portal venous system. Side effects are myocardial, GIT, peripheral ischaemia, ARF, hyponatraemia. Concurrent use of venodilators like nitroglycerin IV infusion, sublingual isosorbide dinitrate may enhance the effectiveness of vasopressin and reduce complications.

Terlipressin: Terlipressin can be used as a better alternative to vasopressin in the control of acute

variceal bleeding because of the beneficial effects in patients with hepatorenal syndrome.

- b. **Somatostatin:** It is a direct splanchnic vasoconstrictor (250 μ g bolus followed by constant infusion of 250 μ g/hr is as effective as vasopressin).
 - c. **Octreotide:** It is a synthetic somatostatin analogue given in a dose of 50 μ g IV bolus followed by 50 μ g/hour. These drugs can be repeated if the bleeding is severe.
 - d. Short acting nitrates (nitroglycerin) via transdermal (10 mg every 12 hours), sublingual (0.6 mg every 30 minutes) or IV (40–400 μ g/min to maintain systolic BP > 90 mm Hg) routes can be tried. They reduce peripheral vasospastic effects of vasopressin and lower the portal pressure further via direct vasodilation of portal-systemic collaterals.
4. Balloon tamponade of bleeding varices by a triple or four lumen Sengstaken-Blakemore's tube with two balloons (gastric/oesophageal). Complications like aspiration pneumonitis, oesophageal rupture are common depending on the length of time the balloon is kept inflated. Hence, it has to be deflated after 24 hours. If bleeding has stopped, the tube may be removed in another 24 hours.
 5. Endoscopic sclerotherapy can be done using sclerosants like sodium morrhuate, absolute alcohol, tetradecyl, ethanolamine oleate, etc. After control of bleeding, sclerotherapy has to be continued for several weeks to months till the varices are fully obliterated.
 Complications – ulceration, stricture, perforation, pleural effusion, ARDS, sepsis
 6. Endoscopic band ligation of varices.
 It is the procedure of choice in non-bleeding varices. Complications include superficial ulceration, stricture and dysphagia.
 7. **Surgery:** Creation of portal systemic shunt to permit decompression of portal system.
 - a. Non-selective shunts to decompress entire portal system, e.g. end to side or side to side portocaval and proximal splenorenal anastomosis. Portal systemic encephalopathy is common.
 - b. Selective shunts decompress only the varices allowing blood flow to the liver itself, e.g. distal splenorenal shunt.
 - c. Splenectomy—for isolated fundal varices caused by splenic vein thrombosis.

No prophylactic shunt surgery or sclerotherapy should be done on patients with non-bleeding varices.



8. Prevention of recurrent bleeding
 - a. Oral beta-blockers, long-acting nitrates
 - b. Sclerotherapy
 - c. Band ligation
 - d. Transjugular intrahepatic portosystemic stent shunting (TIPSS)
 - e. Portosystemic shunt surgery.
9. *Liver transplantation*: It is curative for portal hypertension (not in the acute setting of variceal bleed) and should be reserved for patients with advanced liver disease.

Prognosis

Forty to seventy per cent of those bleeding from varices for the first-time die. The prognosis depends upon the various criteria given in modified Child's classification.

Unfavourable Signs

1. Jaundice
2. Ascites
3. Hypoalbuminaemia
4. Encephalopathy.

Ascites

Ascites refers to accumulation of free fluid in peritoneal cavity.



Causes of Ascites

1. Hepatic cirrhosis
2. Malignant disease
 - a. Hepatic
 - b. Peritoneal
3. Infection
 - a. Tuberculosis
 - b. Bacterial peritonitis
4. Hypoproteinaemia
 - a. Nephrotic syndrome
 - b. Protein losing enteropathy
 - c. Malnutrition
5. Cardiac failure; constrictive pericarditis (ascites precox)
6. Hepatic venous occlusion
 - a. Budd-Chiari syndrome
 - b. Venocclusive disease
7. Pancreatitis (ascitic fluid amylase > 1000 units/L)
8. Lymphatic obstruction—chylous ascites
9. Uncommon causes
 - a. Meig's syndrome
 - b. Vasculitis

- c. Hypothyroidism
- d. Renal dialysis.

Features	Transudate	Exudate
Ascitic fluid protein	< 25 gm/L	> 25 gm/L
Serum-ascitic fluid	> 1.1/dL	< 1.1/dL
Albumin gradient		
Specific gravity	< 1.018	> 1.018

Pathogenesis

Ascites occurs because of the imbalance between the formation and resorption of peritoneal fluid. In cirrhosis of liver, the ascites is due to:

1. Portal hypertension.
2. Renal changes resulting in increased sodium and water resorption. There is stimulation of renin-angiotensin-aldosterone system, increased ADH release and decreased release of natriuretic hormone or third factor.
3. Imbalance between the formation and removal of hepatic and gut lymph.
4. Hypoalbuminaemia.
5. Elevated plasma vasopressin and epinephrine levels in response to a volume-depleted state, accentuates renal and vascular factors.

Portal hypertension is not associated with ascites unless there is concomitant hypoalbuminaemia.

Transudate	Exudate
1. Cirrhosis of liver	1. Bacterial infections
2. Right sided venous hypertension	2. Tuberculosis
3. Hypoalbuminaemia (nephrosis, protein losing enteropathy)	3. Tumour
4. Constrictive pericarditis	
5. Hepatic venous thrombosis	
6. Meig's syndrome	

Ascitic fluid should be analysed in the following ways:

1. Gross appearance: Blood stained fluid is unusual in uncomplicated cirrhosis. It suggests TB/neoplasm.
2. Protein content (given in the table).
3. Differential cell count: If the fluid is a transudate, and contains > 250 WBCs/mL, it suggests tumour or infection. Detailed cytoanalysis is given in the table in next page.
4. Cytology for the presence of malignant cells.
5. Gram's stain, smear and culture for AFB.

Spontaneous Bacterial Peritonitis (SBP)

It is defined as infected ascitic fluid in the absence of recognisable secondary cause of peritonitis. It is



SAAG directly correlates with portal pressure. If SAAG is > 1.1 (High gradient) ascites is due to portal hypertension
SAAG: (Serum albumin – Ascitic fluid albumin Gradient)

Conditions	Colour of ascitic fluid	Specific gravity	Protein in gm/lit	RBC >10,000/ μ L	WBC/ μ L	Other tests
Cirrhosis of liver	Straw coloured/ bile stained	< 1.016 (95%)	< 25	1%	< 250 (mesothelial)	
Neoplasm	Straw coloured Hgic, mucinous, chylous	Variable > 1.016	> 25	20%	> 1000 variable cells	Cytology, cell block, peritoneal biopsy
Tuberculosis hgic, chylous	Clear, turbid, > 1.016	variable	> 25	7%	> 1000 (70%)	Peritoneal biopsy, stain, culture for AFB
Pyogenic peritonitis	Turbid or purulent	If purulent > 1.016	If purulent > 25	Unusual	lymphocytes Predominantly polymorphs	Positive gram stain or culture
CCF	Straw coloured	Variable < 1.016	Variable 15–53	10%	< 1000 (90%) mesothelial/ mononuclear	
Nephrosis	straw coloured/ chylous	< 1.016	< 25 (100%)	Unusual	< 250, mesothelial / mononuclear	If chylous ether extraction/ Sudan stain
Pancreatic ascites (Pseudocyst)	Turbid/Hgic/ chylous	Variable > 1.016	Variable > 25	Variable/ blood stained	Variable	— amylase in ascitic fluid/ serum

associated with an ascitic protein of < 1 gm/dL. SBP can occur in upto 30% of individuals.

Organisms

Coliforms, streptococci, Campylobacter; usually infection is blood-borne.

Ascitic fluid infection can also be due to *staph. aureus* and enterococcus. *E. coli* infection is more common.

Mechanism: Bacterial translocation from the gut through mesenteric node.

Cultures are more likely to be positive when 10 ml of ascitic fluid is inoculated into two culture bottles at the bed side.

If more than two organisms are identified in culture, secondary bacterial peritonitis due to perforation should be considered.



Clinical Features

Fever, abdominal pain, tenderness. Reduced bowel sounds and worsening of hepatic encephalopathy.

Criteria for Diagnosis

1. Clinical features + polymorphs > 250/cmm
2. If polymorphs > 500/cmm, even without clinical features.



Management

Inj cefotaxime 1 gm IV tds for 5-7days is the preferred empirical therapy.

Prophylactic maintenance therapy can be done using T. Norfloxacin 400 mg/day or T. Ciprofloxacin 750 mg weekly.

Chylous Ascites

The fluid is milky, creamy and turbid due to the presence of thoracic or intestinal lymph. Sudan staining of fat globules microscopically and increased triglyceride content (> 1000 mg/dL) by chemical examination clinches the diagnosis.

However, triglyceride concentration of > 200 mg/dL is sufficient for the diagnosis.



Causes

Due to lymphatic obstruction from trauma, tumour, TB, nephrosis, pancreatitis, filariasis or congenital lymphatic obstruction.

Mucinous Ascites

Occurs in pseudomyxoma peritonei or colloid carcinoma of stomach or colon with peritoneal implants.



Investigations

1. Ascitic fluid analysis
2. *Plain abdomen X-ray*: Demonstrates haziness of the abdomen with loss of psoas shadow.
3. *Ultrasonogram of abdomen*: It detects as little as 30 ml of ascitic fluid in the right lateral decubitus position. Loculated collections can also be identified.
4. *CT scan abdomen*: In addition to evaluation of intra-abdominal anatomy, it detects small amounts of ascites also.



Management

1. Daily weight chart, IO chart, bed-rest
2. Indications for diuretics:
 - a. Gross ascites
 - b. Tense ascites with umbilical hernia
 - c. For facilitating biopsy, scan or venogram
 Spironolactone can be given as single dose – 100 mg od. Frusemide 40-80 mg/day may be added particularly in patients who have peripheral oedema. If adequate ascitic fluid is not mobilised, the dose of spironolactone and frusemide can be increased upto 400-600 mg and 120-160 mg/day respectively.
3. Fluid restriction up to 1500 ml/day and salt restriction of 2 gm/day
4. Paracentesis in severe distension causing respiratory embarrassment
5. Peritoneal shunt in intractable ascites
6. Albumin can be infused
7. Treat the cause.

Refractory Ascites

Refractory ascites is defined as ascites unresponsive to a sodium restricted diet and high dose diuretic treatment. It is of two types.

1. Diuretic resistant ascites
2. Diuretic intractable ascites

Diuretic resistant ascites:

Ascitic fluid cannot be mobilised or the recurrence cannot be prevented due to lack of response to 40 mmol sodium diet with intensive diuretic therapy (spironolactone 400 mg/day and frusemide 160 mg/day).

Diuretic intractable ascites:

Ascitic fluid cannot be mobilised and the recurrence cannot be prevented due to the development of diuretic induced complications that preclude the use of an effective diuretic dosage. Renal impairment, hepatic encephalopathy or electrolyte disorder are the usual contraindications for effective diuretic therapy.

In about 10–20% of patients with ascites, medical therapy is a failure. The conditions contributing to refractory ascites resulting in worsening of the primary liver disease are:

- a. Active inflammation
- b. Portal or hepatic vein thrombosis
- c. GI bleed
- d. Infection
- e. SBP
- f. Malnutrition
- g. Hepatoma
- h. Superimposed cardiac and renal disease
- i. Hepatotoxic and nephrotoxic drugs.



Treatment

1. *Peritoneovenous shunt (LeVeen or Denver shunt)*: PV shunt routes the ascitic fluid subcutaneously from the peritoneal cavity into the internal jugular vein through a pressure activated one-way valve. The complications are peritonitis, sepsis, DIC, CCF and ruptured oesophageal varices. Shunt may get occluded in 30% of the patients and may require replacement. Contraindications to this procedure are sepsis, CCF, malignancy and history of variceal bleeding.
2. *Therapeutic paracentesis*: The procedure involves removal of 4–6 litres of ascitic fluid until the abdomen is completely evacuated. Dietary sodium restriction and diuretics should be continued to prevent rapid reaccumulation of ascitic fluid. The procedure may be repeated every 2–4 weeks. But it may result in protein and opsonin depletion which can pre-dispose to SBP. Albumin infusion is very costly and its replacement after large paracentesis remains controversial.
3. *Liver transplantation*: The 12 months survival of patients with ascites refractory to medical therapy is only 25%. The survival increases to 75% with liver transplantation.

Fulminant Hepatic Failure

It is a rare syndrome in which hepatic encephalopathy results from sudden severe impairment of hepatic function. It occurs within 8 weeks of onset of precipitating illness, in the absence of pre-existing liver disease.



Causes

1. Any viral hepatitis (*HDV + HBV increases risk)



2. *Drugs (paracetamol excess, INH, methyldopa, halothane)
3. Fulminant Budd-Chiari syndrome
4. Acute fatty liver of pregnancy
5. Toxins—carbon tetrachloride
6. Weil's disease
7. Wilson's disease
8. Reye's syndrome.

Note: *Poor prognosis.



Clinical Features

Patients may present with neuropsychiatric changes, stupor, coma, symptoms and signs of cerebral oedema, profuse sweating, haemodynamic instability, tachyarrhythmias, tachypnoea, fever, papilloedema, decerebrate rigidity, deep jaundice, coagulopathy, bleeding, renal failure, acid-base disturbance, hypoglycaemia, acute pancreatitis, cardiorespiratory failure and infections.

Poor Prognostic Indicators

1. Age < 10 or > 40 years
2. If hepatic failure is due to halothane or non-A, non-B hepatitis
3. Duration of jaundice of 1 week before the onset of encephalopathy
4. Serum bilirubin > 18 mg/dL
5. Coma
6. Rapid reduction in liver size
7. Respiratory failure
8. Prolongation of prothrombin time
9. Factor V level < 20%
10. In acetaminophen overdose, blood pH < 7.3, serum creatinine > 3 mg/dL and prolonged prothrombin time.



Treatment

1. Endotracheal intubation
2. Prevent GI bleeding with H₂ receptor blockers and antacids
3. Monitor serum glucose level and administer 10–20% dextrose when needed
4. IV mannitol may be beneficial
5. N. acetylcysteine therapy in paracetamol poisoning.
6. FFP to control active bleeding.
7. Liver transplantation should be considered in patients with grade III and IV encephalopathy and other adverse prognostic indicators.

Hepatic Coma (Hepatic Encephalopathy)

It is a complex neuropsychiatric syndrome characterised by disturbances in consciousness level and behaviour, personality changes, fluctuating neurological signs, asterixis and distinctive electroencephalographic changes.

There are two types of hepatic coma:

1. Acute or subacute—reversible
2. Chronic—progressive leading to irreversible coma and death.

Precipitating Factors

1. Increased nitrogen load (gastrointestinal bleeding, excessive dietary protein, uraemia, constipation).
2. Electrolyte imbalance (hypokalaemia, alkalosis, hypoxia, hypovolaemia).
3. Drugs (narcotics, tranquilizers, sedatives, diuretics).
4. Others (infection, surgery, acute and progressive liver disease).
5. Large binge of alcohol.
6. Large volume of paracentesis.
7. TIPS.

Pathogenesis

Abnormality in the nitrogen metabolism in which ammonia and/or other amines (octapamine, amino acids and GABA) formed in the bowel by the action of urease containing organisms, are carried in the portal circulation to the liver, fail to get detoxified due to hepatocellular disease or portal systemic shunt of blood or both. These substances enter systemic circulation where they interfere with cerebral metabolism.



Clinical Features

- Main feature is the derangement of consciousness, altered sleep rhythm, increased psychomotor activity followed by progressive drowsiness, stupor and coma. Severe brain oedema may occur.
- There may be extrapyramidal signs. There may be exaggeration of deep tendon reflexes and plantars may be extensors.
- There is also dysarthria, mild alexia, with focal or generalised seizures.
- Asterixis or flapping tremor is a characteristic feature of impending hepatic coma.
- Change in hand writing, constructional apraxia and fetor hepaticus, a unique musty odour of the breath due to mercaptans may also be present.

Classification

Hepatic coma can be classified into four stages as follows:

Stage	Mental status	Asterixis	EEG
I	Euphoria or depression, mild confusion, slurred speech, disorders of sleep	+/-	Usually normal
II	Lethargy, moderate confusion	+	Abnormal
III	Marked confusion; incoherent speech; patient is arousable from sleep	+	Abnormal
IV	Coma; patient initially responsive to noxious stimuli, later becomes non-responsive	-	Abnormal

Diagnosis

It is only by exclusion

1. No pathognomonic liver function abnormality
2. Elevation of serum ammonia
3. CSF analysis is normal
4. CT scan of brain does not show any abnormality
5. EEG shows high voltage, slow wave forms (reduced alpha rhythm and increased delta activity; delta waves 3–4 cycles/second). It is the earliest sign in hepatic encephalopathy. There is slowing or flattening of waves with 3:1 high-voltage waves.

In the presence of jaundice, portal hypertension or ascites, the cause for coma is most likely to be of hepatic origin.

Treatment

1. Elimination of precipitating factors.
2. Nasogastric aspiration (in case of bleeding) and protection of airway with a endotracheal tube.
3. Avoid constipation and favour bowel emptying by bowel wash, enema or by lactulose (30–50 ml 3 to 4 times daily) or lactitol.
4. Bowel sterilisation by neomycin 1 gm qid or ampicillin. Neomycin helps in decreasing ammonia production or its absorption from the bowel. Rifaximin 400 mg tid can also be used.
5. Avoid drugs, especially sedatives and diuretics.
6. Protein is restricted and vegetable based protein may be given.
7. IV mannitol as a fast drip for reducing cerebral oedema.
8. The use of agents like levodopa, bromocryptine, ketoanalogues of amino acids and intravenous infusion of amino acids in the treatment of acute hepatic encephalopathy is unclear. So also haemo-

perfusion to remove toxic substances and treatment of cerebral oedema.

9. Zinc supplementation is sometimes helpful.
10. Liver transplantation.

Hepatorenal Syndrome

It is a progressive functional renal failure occurring in patients with severe liver disease. Mostly patients have decompensated cirrhosis and tense ascites. The kidneys are anatomically, histologically and functionally normal.

Hepatorenal syndrome occurs in 10% of patients.

Precipitating factors:

- SBP
- Large volume of paracentesis without volume expansion.

Defective clearance of vasoconstrictor substances by the liver leads to intra-renal vasoconstriction and ultimately hepatorenal syndrome. There are two types.

1. *Type I:* Acute onset of rapidly progressive (< 2 weeks) oliguric renal failure unresponsive to volume expansion with doubling of initial serum creatinine value greater than 2.5 mg/dL or 50% reduction in the initial 24 hours creatinine clearance—less than 20 ml/minute. It has poor prognosis and 80 % mortality at 2 weeks.
2. *Type II:* There is reduction in GFR with increased creatinine level, but is stable and slowly progressive and it has better prognosis.

Pathogenesis

The haemodynamic alterations in kidneys are as a result of decreased effective blood volume and increased sympathetic tone. Increased intra-abdominal and renal venous pressure and alteration of balance between vasoactive humoral agents such as renin-angiotensin, prostaglandins, thromboxanes, kinins, endotoxins, and renal kallikrein may play a role. Involvement of endothelin-1 and 3 has been implicated in hepatorenal syndrome. Role of nitric oxide has also been suggested as one of the mechanisms.

Criteria for Diagnosis of Hepatorenal Syndrome

Major criteria

1. Chronic or acute liver disease with advanced hepatic failure and portal hypertension.
2. Low GFR indicated by S creatinine > 1.5 mg% or creatinine clearance less than 40 ml/min.
3. Absence of treatment with nephrotoxic drugs, shock, infection or significant fluid loss.



- No sustained improvement in renal function after diuretic withdrawal and volume expansion with 1.5 litres of isotonic saline.
- Proteinuria < 500 mg% and no USG evidence of obstructive or parenchymal renal disease.

Additional criteria

- | | |
|-----------------------|---------------------|
| 1. Urine volume | < 500 ml/d |
| 2. U. Na ⁺ | < 10 mEq/litre |
| 3. U osmolality | > Plasma osmolality |
| 4. Urine RBC | < 50/hpf |
| 5. S. Na ⁺ | < 130 mEq/litre |



Management

- Identification, removal and treatment of any factors precipitating renal failure (diuretics to be stopped, blood volume to be replenished during dehydration or hemorrhage, infections to be treated, avoid nephrotoxic drugs).
- Saline or salt poor albumin or plasma to be administered till diuresis occurs. If diuresis does not occur, infusion is to be stopped.
- Systemic vasoconstrictor telipressin may be used.
- Currently midodrine (α agonist) with octreotide and IV albumin are used to treat hepatorenal syndrome.
- Dialysis*: It is indicated in patients with potentially reversible liver disease to allow the liver to regain its function.
- Surgery*: Liver transplantation and portacaval shunts have been tried. Liver transplantation is the only definitive treatment.

Hepatopulmonary Syndrome

Hepatopulmonary syndrome is characterised by:

- Advanced chronic liver disease
- Arterial hypoxaemia (decreased PaO₂)
- Intra-pulmonary vasodilatation (Defective clearance of vasodilator substances by the liver leads to intra-pulmonary vasodilatation)
- No primary cardio-pulmonary disorder



Clinical Features

- Dyspnoea in upright posture (Platypnoea)
- Oxygen desaturation in upright position (Orthodeoxia)



Investigations

- Contrast enhanced ECHO
- Technitium Tc⁹⁹ macro-aggregated albumin lung perfusion scan



Treatment

- Oxygen supplementation to maintain PaO₂ > 60 mm of Hg
- Drugs like almitrine, methylene blue and even garlic powder which increase pulmonary vascular resistance and pulmonary arterial pressure are used.
- TIPS may be used
- Liver transplantation is the only effective mode of treatment.

Hepatocellular Carcinoma (Hepatoma)

Hepatoma is 4 times more common in men. It commonly arises in a cirrhotic liver.

Aetiology

- Chronic hepatitis B, C infection especially in a cirrhotic liver
- Aflatoxin B₁ (loss, inactivation or mutation of the P⁵³ gene)
- Haemochromatosis
- Alpha-1 antitrypsin deficiency
- Alcoholic cirrhosis; rarely in primary biliary cirrhosis
- Thorotrast, arsenic (causes angiosarcoma also)
- Oestrogens, androgens, anabolic steroids (causes adenoma also). Contraceptive steroids used for > 8 years may increase the risk by 4-fold
- NASH (non-alcoholic steatohepatitis).

Pathology

Macroscopically, there is a single mass or multiple nodules. Microscopically, tumour is made up of well-differentiated cells secreting bile.



Clinical Features

Patients may present with fever of unknown origin, abdominal pain, right upper quadrant abdominal mass, friction rub or bruit over the liver, haemorrhagic ascites or occasionally intra-abdominal bleeding.

Paraneoplastic manifestations are:

- Erythrocytosis (due to erythropoietin like substance)
- Hypercholesterolaemia
- Hypercalcaemia (due to PTH like substance)
- Hypoglycaemia
- Acquired porphyria
- Dysfibrinogenaemia
- Cryofibrinogenaemia.



Investigations

1. Serum alkaline phosphatase: mildly elevated
2. Serum alpha-fetoprotein > 500 µg/l; persistence of levels over 500–1000 µg/l in an adult with liver disease and without obvious GIT tumours or gonadal malignancies suggests hepatocellular carcinoma. Increasing levels suggest progression of the tumour or recurrence after hepatic resection/chemotherapy/chemoembolisation
3. *Imaging techniques:* USG abdomen detects tumours of 2–3 cm in size; CT scan of the liver helps in the accurate evaluation of tumour and also to identify enlarged lymph nodes (Fig. 5.36)
4. *Liver biopsy:* Diagnostic biopsy can be taken in an area localised by USG or CT. Risk of tumour cell migration along the biopsy track is small. Since the tumours are vascular, biopsies should be done with caution
5. Detection of des gamma carboxyl prothrombin
6. Cytology of ascitic fluid rarely shows malignant cells
7. Laparoscopy or minilaparotomy can be done to take the biopsy under direct vision
8. Investigations to rule out paraneoplastic syndrome
9. *Angiography:* Celiac axis angiography can determine operability in a patient with hepatoma or solitary metastasis to the liver.



Fig. 5.36: CT scan—hepatoma left lobe



Management

1. Surgical resection (hepatoma or single metastasis confined to one lobe)
2. Hepatic artery embolisation with chemotherapy
3. Alcohol ablation via USG guided percutaneous injection

4. USG guided cryoablation
5. Immunotherapy using monoclonal antibodies tagged with cytotoxic agents
6. Gene therapy with retrievable vectors containing genes which express cytotoxic agents
7. *Liver transplantation:* Recurrence/metastasis in the transplanted liver is common.

Prognosis

If untreated, patients usually die within 3–6 months of diagnosis. Monitor course of illness with serial USG, alpha-fetoprotein especially in HBsAg positive patients or patients with cirrhosis due to hepatitis C infection.

Metabolic Liver Disease Wilson's Disease (Fig. 5.38)

Wilson's disease is an autosomal recessive disorder. The genetic defect is on chromosome 13. In 95% of patients, there is also an absence or deficiency of serum ceruloplasmin, the main copper transporting protein in blood, usually associated with the defect in ceruloplasmin gene on chromosome 3.



Clinical Features (Fig. 5.37)

The average age at presentation of liver dysfunction is 6–20 years, but it can manifest later in life.

It can present as neuro-psychiatric disorder, chronic active hepatitis, fulminant hepatitis, cirrhosis of liver, acquired haemolytic anaemia, ophthalmic problems like sunflower cataracts and Kayser-Fleischer rings (copper deposits laid in the Descemet's membrane around the periphery of cornea).

Renal abnormalities are due to accumulation of copper within the renal parenchyma resulting in decreased GFR, proximal tubular defects resembling Fanconi's syndrome, renal tubular acidosis, haematuria and proteinuria.



Investigations

1. *Serum ceruloplasmin:* Low, often less than 20 mg/dl.
2. *Serum copper level:* Total serum copper often decreased but free copper is elevated. Free copper is calculated by finding the difference between total serum copper and the amount of copper bound to ceruloplasmin (0.047 µmol of copper/mg of ceruloplasmin).
3. *Urine copper excretion:* Levels greater than 1.6 mmol/day is suggestive of Wilson's disease. However, urine

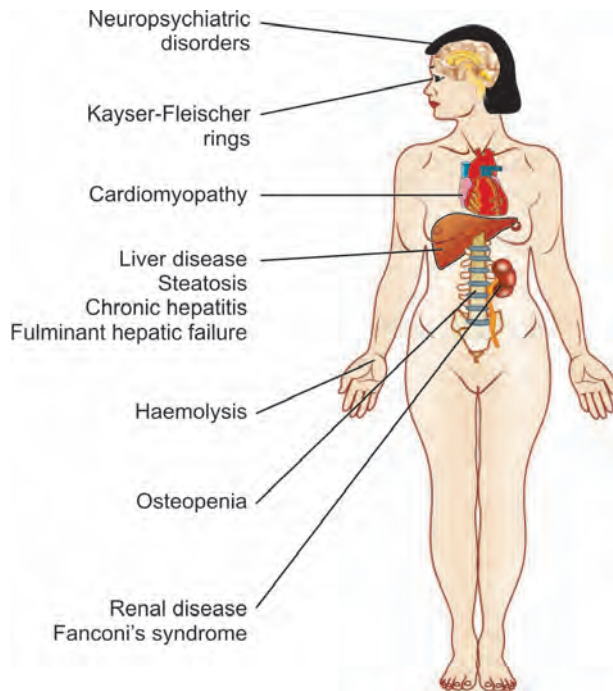

Fig. 5.37: Clinical manifestations of Wilson's disease

copper levels are high in other conditions like cirrhosis, chronic active hepatitis or cholestasis.

4. *Liver biopsy*: It should be done for histology and for hepatic copper estimation. Hepatic copper

concentration more than 250 $\mu\text{g/gm}$ of dry tissue is compatible with the diagnosis of Wilson's disease.

5. *Kayser-Fleischer ring*: It is present in all patients with Wilson's disease who have neurological manifestation. It should be sought with slit-lamp examination.
6. Low serum alkaline phosphatase and elevated aminotransferase.
7. *Radiocopper loading test*: In normal persons after giving radioactive copper, it disappears from serum within 4–6 hours. A secondary rise of radioactivity appears after the isotope is incorporated into ceruloplasmin production. In patients with Wilson's disease, the secondary rise is absent since they cannot incorporate radiocopper into ceruloplasmin.



Management

See table below.

Haemochromatosis

It is a disorder in which there is excessive iron absorption either alone or in combination with parenteral iron loading, leading to progressive increase in total body iron stores.

Disease status	1st choice	2nd choice
Hepatitis/Cirrhosis without de-compensation	Zinc	Trientine
Hepatic de-compensation		
Mild	Trientine and Zinc	Penicillamine and Zinc
Moderate	Trientine and Zinc	Hepatic transplant
Severe	Hepatic transplant	Trientine and Zinc
Initial neurologic/psychiatric	Tetrathiomolybdate and Zinc	Trientine and Zinc
Maintenance	Zinc	Trientine
Pre-symptomatic	Zinc	Trientine
Paediatric	Zinc	Trientine
Pregnant	Zinc	Trientine

Zinc should not be ingested simultaneously with trientine as it chelates zinc.

Zinc acetate – 50 mg of elemental zinc three times daily

Trientine hydrochloride – 500 mg bid an hour before or two hours after food.

Tetrathiomolybdate 120 mg/day (20 mg tid with meals and 60 mg at bed time 2 hours after dinner) along with zinc therapy.

Anti-copper therapy must be life-long.

Liver transplantation is ideal for end stage liver disease.

Low copper containing diet should be taken. Foods rich in copper, like organ meats, shell-fish, dried beans, peas, whole wheat, and chocolate should be avoided.

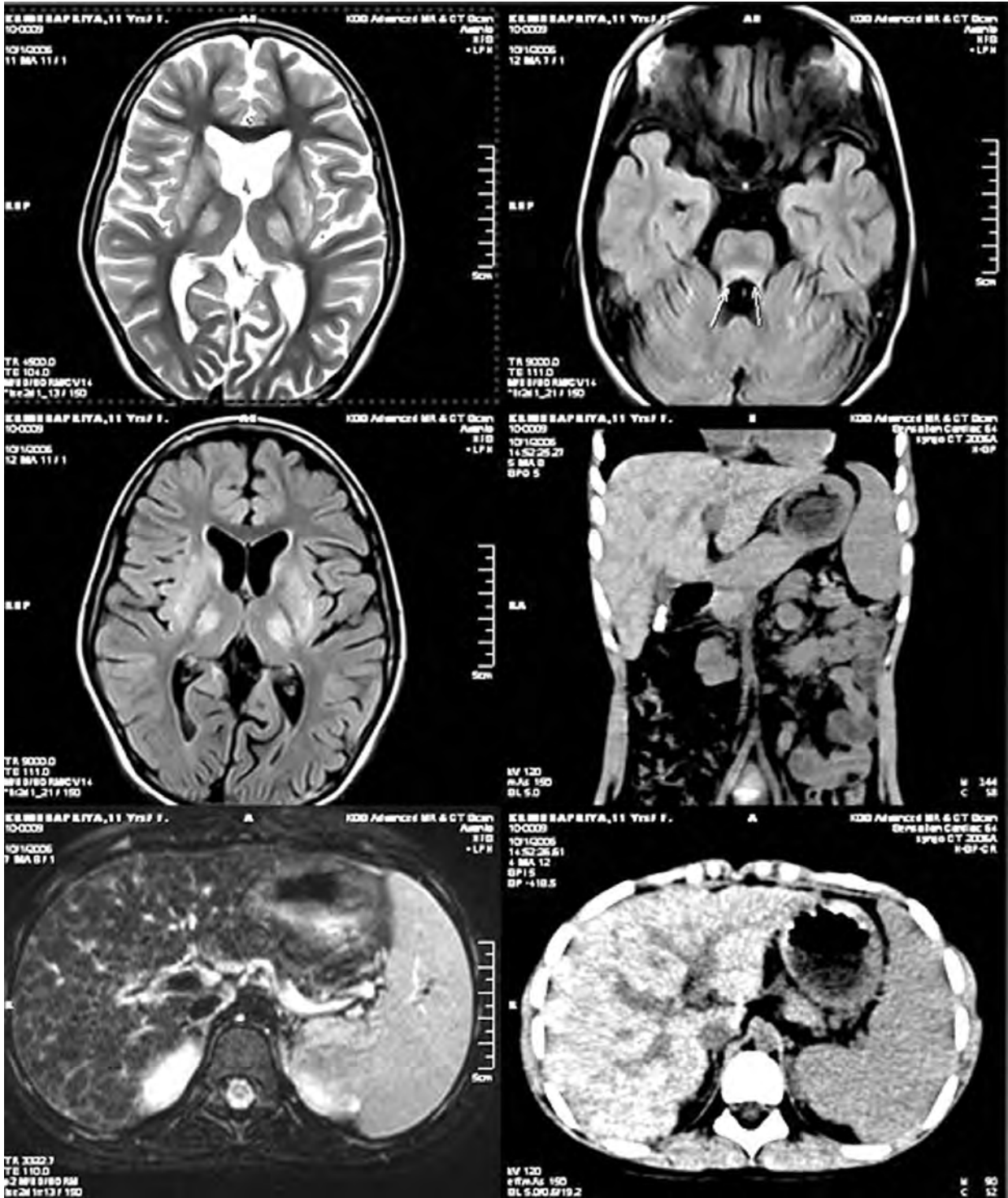

Fig. 5.38: Wilson's disease: T2-weighted axial MRI demonstrates symmetric hyperintense signals in the putamen, posterior internal capsule, and thalami (arrows), "face of the giant panda" in midbrain with high signal in tegmentum and normal red nuclei (arrows), hypointensity of central tegmental tracts with hyperintensity of aqueductal opening to fourth ventricle (arrows).

CT abdomen: chronic liver disease (cirrhosis) with splenomegaly

MRI abdomen: diffuse hypointensities suggestive of copper deposition



Classification

1. Primary or idiopathic
2. Secondary
 - a. Refractory anaemia
 - b. Chronic liver injury
 - c. Dietary iron overload
 - d. Porphyria cutanea tarda
3. Parenteral iron overload
 - a. Multiple blood transfusions
 - b. Excessive parenteral iron
 - c. Haemodialysis

Idiopathic Haemochromatosis

It is an autosomal recessive disorder with the abnormal gene located in the HLA A6 locus on short arm of chromosome 6.



Clinical Features (Fig. 5.39)

Lethargy, weight loss, change in skin color, loss of libido, abdominal pain, arthralgia, symptoms of diabetes mellitus (65%) are common modes of presentation.

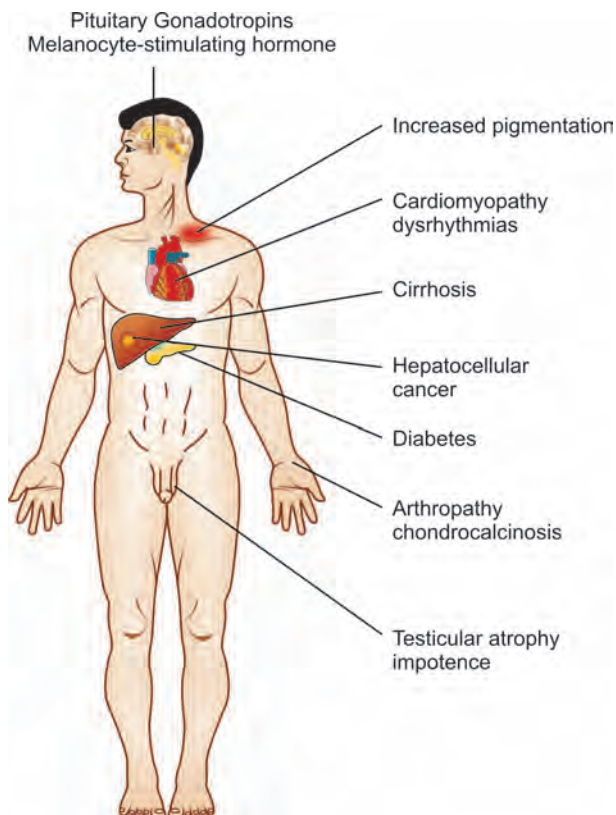

Fig. 5.39: Clinical manifestations—haemochromatosis

Patients have hepatomegaly, skin pigmentation, testicular atrophy, loss of body hair, CCF (due to congestive cardiomyopathy) and arthritis (osteoarthritis, pseudogout).

Hepatoma can occur in 30% of patients with cirrhosis. Arrhythmias (atrial and ventricular tachyarrhythmias) and AV blocks are common.



Investigations

1. Serum iron and total iron binding capacity. Serum iron more than 180 to 300 $\mu\text{g}/\text{dl}$ and elevated TIBC suggest haemochromatosis.
2. *Serum ferritin*: It is the most specific screening test for increased iron stores. Serum ferritin level is between 600–900 $\mu\text{g}/\text{L}$ (normal 10–200 $\mu\text{g}/\text{L}$).
3. Transferrin saturation is 50–100% (normal 22 to 46%)
4. Total iron binding capacity is between 200–300 $\mu\text{g}/\text{dL}$ (normal 250–370 $\mu\text{g}/\text{dL}$)
5. *Liver biopsy*: It is helpful in estimating tissue iron by histochemical staining. Hepatic iron concentration by dry weight can also be done and levels > 1000 $\mu\text{g}/100$ mg of dry weight suggests IHC.
6. *CT scan and MRI*: Increased level of iron in liver is associated with an increased CT density or attenuation coefficient. MRI is sensitive in the detection of moderate iron overload.



Management

1. *Phlebotomy*: There is 250 mg of iron in 500 ml of blood. The body burden of iron in IHC is more than 20 gm, a weekly phlebotomy of 500 ml of blood for 2–3 years may be needed to achieve a haemoglobin of 11 and serum ferritin of 10.
2. *Desferrioxamine*: It is an iron chelating agent given in a dose of 40–80 mg/kg/day, subcutaneously. It removes 10–20 mg of iron/day.
3. Oral deferasirox is effective in thalassemia and secondary iron overload.
4. Avoid alcohol.
5. Plan liver transplantation for end stage liver disease.

Prognosis

Hepatocellular carcinoma occurs in one-third of the patients with IHC and cirrhosis, despite iron removal.



Causes of Death

Death may be due to CCF, hepatocellular failure, portal hypertension or hepatoma.

Budd-Chiari Syndrome

It is characterised by thrombosis of larger hepatic veins and sometimes inferior vena cava.

Aetiology

1. Primary proliferative polycythaemia
2. Paroxysmal nocturnal haemoglobinuria
3. Antithrombin III, protein C, S deficiency
4. Pregnancy and oral contraceptive pills
5. Obstruction due to tumours (CA of liver, kidney or adrenals)
6. Congenital venous web
7. Inferior venacaval stenosis



Clinical Features

- Upper abdominal pain
- Tender hepatomegaly
- Marked ascites
- Peripheral oedema (only when IVC is occluded)



Investigations

1. Doppler USG
2. CT and MRI to demonstrate hepatic vein or IVC occlusion
3. Liver biopsy – centrilobular congestion with fibrosis



Treatment

1. Treat the underlying cause
2. Streptokinase followed by heparin and anticoagulants in case of suspected thrombosis
3. Angioplasty for hepatic vein stricture
4. TIPS
5. Liver transplantation

Acute Pancreatitis

The pathologic spectrum of acute pancreatitis varies from oedematous pancreatitis (mild and self-limiting) to necrotising pancreatitis.

In haemorrhagic pancreatitis, there is interstitial haemorrhage.



Causes (Fig. 5.40)

1. Biliary disease (gallstones)
2. Alcohol ingestion (acute and chronic alcoholism)

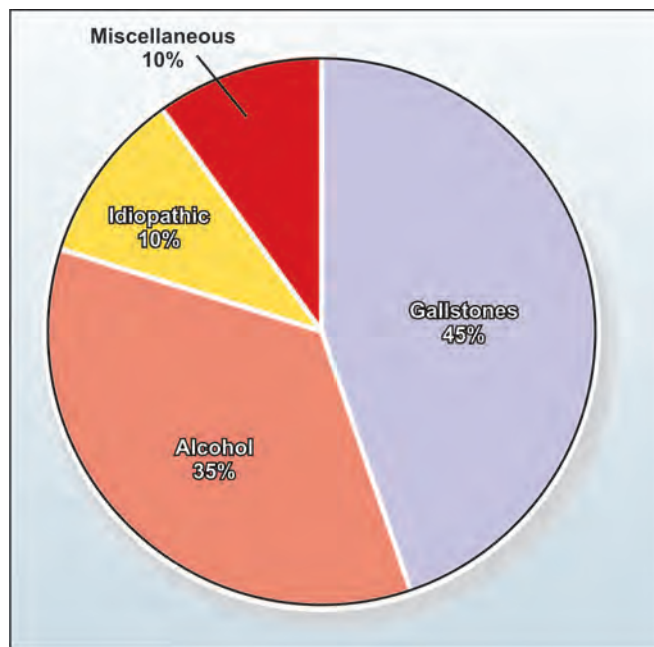

Fig. 5.40: Acute pancreatitis

3. Postoperative (abdominal, non-abdominal)
4. Post-ERCP
5. Trauma
6. Metabolic
 - a. Renal failure
 - b. After renal transplantation
 - c. Hypertriglyceridaemia
 - d. Hypercalcaemia (hyperparathyroidism drugs)
 - e. Acute fatty liver of pregnancy
7. Infections (viral hepatitis, mumps, ascariasis, mycoplasma)
8. Drug induced
 - a. *Definite association:* sulfonamides, oestrogens, frusemide, thiazides, tetracycline, valproic acid.
 - b. *Probable association:* acetaminophen, ethacrynic acid, procainamide, metronidazole, NSAIDs, ACE inhibitors.
9. *Connective tissue disorders:* SLE, thrombotic thrombocytopenic purpura
10. Penetrating peptic ulcer
11. Obstruction to ampulla of Vater (regional enteritis, duodenal diverticulum)
12. Hereditary pancreatitis, pancreas divisum.



Clinical Features

Abdominal pain (mild to severe and constant), nausea, vomiting, abdominal distension (gastric hypomotility) and chemical peritonitis, low grade fever, tachycardia, hypotension (due to exudation of blood and plasma



proteins, vasodilatation due to release of kinin peptides and systemic effects of proteolytic and lipolytic enzymes released into the circulation), jaundice (due to oedema of the head of the pancreas), erythematous skin nodules (due to subcutaneous fat necrosis), basal rales, pleural effusion, diminished bowel sounds, palpable pancreatic pseudocyst, bluish discoloration around the umbilicus (Cullen's sign), bluish red or green brown discoloration of the flanks (Turner's sign); latter two signs indicate severe necrotising pancreatitis.



Investigations

1. *Serum amylase* (no correlation between enzyme level and severity of pancreatitis): Levels increase up to 72 hours and return to normal in 1–2 weeks. Other causes of serum amylase elevation are:
 - a. Pancreatic trauma, carcinoma
 - b. Non-pancreatic disorders—mumps, calculus, macroamylasaemia, DKA, burns, pregnancy, renal transplantation, cerebral trauma, morphine, Ca lung, breast, oesophagus
 - c. Other abdominal causes: biliary tract diseases, perforated or penetrating peptic ulcer, intestinal obstruction, ectopic pregnancy, chronic liver disease.

Serum amylase level has no prognostic value.

2. Serum lipase measurement is preferable to serum amylase as it is equally sensitive and has greater specificity (normal serum lipase 0–160 U/L)
 - Marked elevation of peritoneal or pleural fluid amylase > 5000/dL also suggests pancreatitis.
 - Persistently elevated amylase suggests pancreatic abscess, pseudocyst or non-pancreatic cause.
3. *Abdomen and chest X-ray*: To rule out other causes, perforated viscus.
4. *CT scan*: It is helpful even when the amylase level is normal. CT may show phlegmon (solid mass of swollen inflamed pancreas), pseudocysts (Fig. 5.41) or even pancreatic fluid collection.
5. *USG and radionuclide scanning*: These are useful in evaluating gallbladder and biliary tree (Fig. 5.42).

Poor Prognostic Indicators

1. Ranson/Imrie criteria (scores 7–8)
2. Haemorrhagic peritoneal fluid
3. Organ failure
4. Obesity

1. Ranson/Imrie Criteria

- A. *At admission or diagnosis*
 1. Age > 55 years

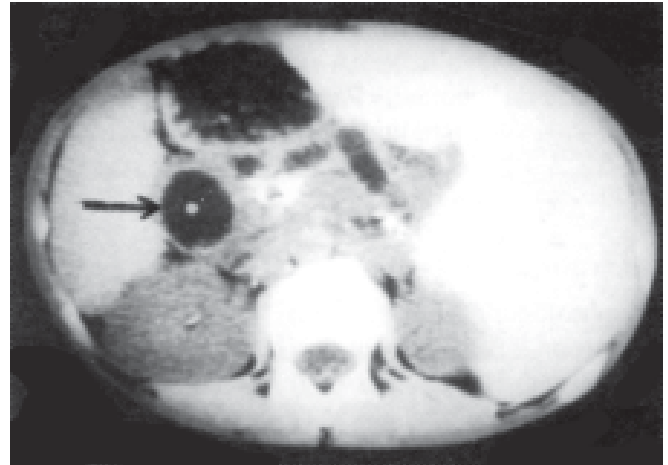

Fig. 5.41: CT scan—pseudocyst pancreas



Fig. 5.42: Endoscopic retrograde pancreatography—pseudopancreatic cyst

2. Leucocytosis > 16,000/cmm
 3. Hyperglycaemia > 200 mg/dL
 4. Serum LDH > 400 IU/L
 5. Serum AST > 250 IU/L.
- B. *During initial 48 hours*
 1. Haematocrit fall > 10%
 2. Fluid sequestration > 4000 ml
 3. Hypocalcaemia < 8 mg/dL
 4. Hypoxaemia (PO_2 < 60 mm Hg)
 5. BUN rise > 5 mg/dL after IV fluids
 6. Hypoalbuminaemia < 3.2 gm/dL.

Prognosis

Mortality correlates as follows considering criteria from A and B.

- | | |
|---------------|---------------|
| 0–2 criteria, | mortality 2% |
| 3–4 | mortality 15% |

5–6	mortality 40%
7–8	mortality 100%.

2. Haemorrhagic Peritoneal Fluid

Key indicators of poor prognosis:

Hypotension—BP < 90 mmHg, tachycardia > 130/min, PO₂ < 60 mmHg, oliguria < 50 ml/hour, serum calcium < 8 mg/dL; serum albumin < 3.2 gm/dL.

Severe Acute Pancreatitis

It is more common in old (> 70 years) and obese (BMI > 30) individuals.

It is often associated with shock, respiratory failure (PaO₂ < 60 mm of Hg), renal failure (serum creatinine > 2 mg) and GI bleed. Multi-organ failure is common with Ranson criteria > 3 and Apache II score > 8.



Differential Diagnosis

Acute abdomen, myocardial infarct.



Complications

Systemic

- Shock and renal failure
- Diabetes mellitus
- Hypocalcaemia (Rx 10 ml of 10% calcium gluconate IV slowly)
- Subcutaneous fat necrosis
- Respiratory failure
- DIC
- Transient hyperglycaemia.

Pancreatic (after 1 week)

Abscess, pseudocyst.

Gastrointestinal

Haemorrhage, ileus, duodenal obstruction (mechanical), obstructive jaundice.



Management

The basic principles of management are:

- Nil orally
- IV fluids and colloids to maintain normal intravascular volume
- Pain relief using analgesic
- Nasogastric suction to decrease gastrin release from stomach
- Monitor pulse, BP, urine output, Serum amylase, Serum lipase, glucose, calcium and blood gases.

- Laparotomy and debridement in haemorrhagic pancreatitis
- Antibiotic therapy using agents that achieve high pancreatic tissue concentration decreases the mortality especially in necrotising pancreatitis. The agents include imipenem, ofloxacin and ciprofloxacin.
- Other drugs with variable efficacy include
 - Glucagon
 - H₂ receptor blocker
 - Protease inhibitor—aprotinin
 - Glucocorticoids
 - Calcitonin
 - NSAIDs
 - Octreotide
 - Lexipilafant—platelet activating factor inhibitor
 - Gabexate methylate—an antiprotease.

Chronic Pancreatitis (Fig. 5.43)

Chronic inflammation of pancreas may present as episodes of acute inflammation superimposed on a previously injured pancreas or as chronic damage with persistent pain or malabsorption.

Prolonged consumption of socially acceptable levels of alcohol, i.e. 30 gm/day or less may result in pancreatitis. Cholelithiasis, stenosis of sphincter of Oddi, may cause pancreatitis or it may be familial.

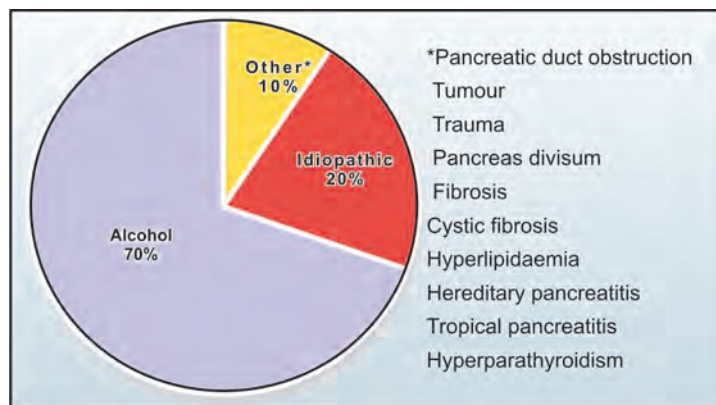

Fig. 5.43: Chronic pancreatitis



Clinical Features

Pancreatitis pain is continuous or intermittent or even it may be absent. Referred pain may be felt over anterior chest or flank. Pain is often increased by alcohol or fat rich heavy meals.



Weight loss, diarrhoea, steatorrhoea, minimal abdominal tenderness and mild fever also occur.



Investigations

1. Plain abdomen X-ray shows calcification of pancreas
2. USG and CT show pancreatic atrophy, calcifications, dilatations and stricture of CBD (Fig. 5.44).

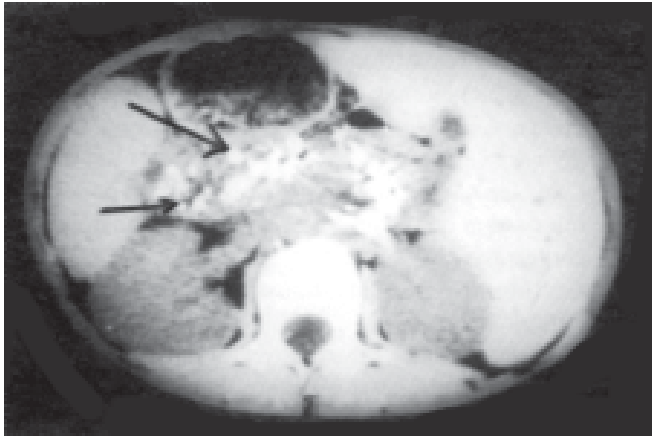

Fig. 5.44: CT scan—pancreatic calcification

3. ERCP while planning surgery
4. Pancreatic function tests
 - a. *N-benzoyl-tyrosyl-PABA test*: Normal test excludes pancreatic insufficiency
 - b. *Secretin/CCK/stimulation test*: To confirm pancreatic insufficiency
 - c. *GTT*: It is done to demonstrate diabetes mellitus
 - d. Fecal fat excretion after 5 days stool collection to demonstrate steatorrhoea
 - e. *LFT*: Increased alkaline phosphatase indicates biliary obstruction.



Treatment

1. *Pancreatic extracts*: 10,000–12,000 lipase units/meal. It causes reduction in faecal fat excretion.
2. H₂ blockers and antacid to prevent inactivation of pancreatic extract by gastric acid.
3. Abstinance of alcohol, low fat diet (medium chain triglycerides do not require lipase for absorption and hence can be given).
4. Operations for unremitting pain
 - Pancreatectomy
 - End to end or side to side pancreatico-jejunostomy.

Tropical Pancreatitis

Tropical pancreatitis is a juvenile form of chronic calcific non-alcoholic pancreatitis found almost exclusively in the tropical world. It is characterised by recurrent abdominal pain, intraductal pancreatic calculi, exocrine pancreatic insufficiency and diabetes. The unique features of this condition are:

1. Affects younger people
2. Relatively accelerated course
3. Not associated with alcoholism.

Aetiology

This is not clearly established. The theories are:

1. Under nutrition .
2. Cassava diet which contains cyanogenic glycosides
3. Familial and genetic predisposition
4. Oxidant stress
5. Infectious—Coxsackie and viral hepatitis.



Clinical Features

Affects males mostly with a mean age of 20 years, usually with poor socio-economic status. The usual findings include protein energy malnutrition, bilateral parotid enlargement, abdominal distension, growth retardation and a peculiar cyanotic hue of the lips. The abdominal pain is classically epigastric with radiation to back, persistent and precipitated by heavy fat rich diet or alcohol. Exocrine pancreatic deficiency manifests in the form of steatorrhoea and correlates directly with endocrine damage.

Comparison between Alcoholic and Tropical Pancreatitis

	<i>Alcoholic pancreatitis</i>	<i>Tropical pancreatitis</i>
Age	35–45	20–40
Sex	Males	Males more than females
Diabetes	Less common	More common
Steatorrhoea	More common	Less common
Calculi	Less common	More common
Malignancy	Less common	More common

Liver Transplantation

Liver transplantation has become an accepted life saving procedure when applied earlier in the natural history of end stage liver disease. Orthotopic liver transplantation means implantation of a donor organ, after removal of the native organ, in the same anatomic location.



Cadaver Donor Selection

Cadaver donor liver for transplantation is procured primarily from victims of head injury. Previously, liver transplant allocation was based upon Child Turcotte Pugh score which used five variables; namely, ascites, bilirubin, albumin, encephalopathy, and prothrombin time. Now the allocation is based upon Meld – Score model for end-stage liver disease that includes bilirubin, creatinine, and prothrombin time.

Indications

In Children

1. Biliary atresia
2. Neonatal hepatitis
3. Inherited disorders of metabolism
 - a. Wilson's disease
 - b. Tyrosinaemia
 - c. Glycogen storage diseases
 - d. Lysosomal storage diseases
 - e. Crigler-Najjar syndrome—Type I
 - f. Familial hypercholesterolaemia
 - g. Haemophilia
 - h. Protoporphyrria
 - i. Hereditary oxalosis
4. α_1 -antitrypsin deficiency
5. Congenital hepatic fibrosis
6. Alagille's disease (arteriohepatic dysplasia with paucity of bile ducts, congenital cardiac malformations like PS)
7. Byler's disease—Intrahepatic cholestasis, progressive liver failure, MR, growth retardation.

In Adults

1. Primary biliary cirrhosis
2. Secondary biliary cirrhosis
3. Primary sclerosing cholangitis
4. Caroli's disease (multiple cystic dilatations of biliary tree)
5. Cryptogenic cirrhosis
6. Chronic active hepatitis with cirrhosis
7. Hepatic vein thrombosis
8. Fulminant hepatitis
9. Alcoholic cirrhosis*
10. Chronic viral hepatitis*
11. Primary hepatocellular carcinoma*
12. Hepatic adenoma.

Note: *Controversial indications for liver transplant.

Contraindications

1. Life-threatening systemic disease

2. Uncontrolled extrahepatic bacterial or fungal infection
3. Pre-existing cardiopulmonary disease
4. HIV
5. Active drug/alcohol abuse
6. Multiple uncorrectable life-threatening congenital anomalies.

Relative Contraindications

1. Age > 60 years
2. Highly replicative HBV infection
3. Portal vein thrombosis
4. Pre-existing renal disease (not associated with liver disease)
5. Intrahepatic or biliary sepsis
6. Severe hypoxaemia (right to left intrapulmonary shunts)
7. Previous extensive hepatobiliary surgery
8. Uncontrolled serious psychiatric disorders.



Complications

I. Hepatic

- a. Primary graft failure (as a result of ischaemic injury to the organ)
- b. Vascular compromise (thrombosis/stenosis of portal vein or hepatic artery anastomoses)
- c. Failure or obstruction of biliary anastomosis
- d. Rejection.

Postoperative Jaundice

1. *Prehepatic*: Transfusion (increased Hb pigment, due to haemolysis, haematomas, ecchymoses and other collections of blood).
2. *Intrahepatic*
 - a. *Early intrahepatic*: Drugs or anaesthesia, hypoperfusion injury due to shock, sepsis, benign postoperative cholestasis
 - b. *Late intrahepatic*: Post-transfusion hepatitis, recurrent pulmonary disease.
3. *Posthepatic*: Biliary obstruction and decreased renal clearance of conjugated bilirubin.

II. Nonhepatic

1. Fluid overload in the postoperative period due to massive fluid losses and fluid shifts
2. Continuous monitoring of cardiac and pulmonary function
3. Renal dysfunction (hypoperfusion and ATN)
4. Intraoperative bleeding



5. Anaemia (upper GI bleed or transient haemolytic anaemia, usually of autoimmune origin, transient thrombocytopenia, aplastic anaemia)
6. Bacterial, fungal and viral infections.

In the Immediate Post Transplantation Period

- a. Pneumonia
- b. Wound infections
- c. Infected intra-abdominal collections
- d. UTI
- e. IV line infections.

Beyond the 1st Post Transplantation Period: CMV, herpes, fungal infections (*Aspergillus*, *Nocardia*, *Candida*, *Cryptococcus*), mycobacterial and parasitic infections (*Pneumocystis carinii*, *Toxoplasma*).

Immunosuppression

Various combinations of cyclosporine, glucocorticoids, azathioprine, OKT₃ have been tried.

Live Donor Transplantation

Due to shortage of availability of cadaver organs, live donor transplantation comes into practice. Here, transplantation of the right lobe of the liver from a healthy adult into an adult recipient or left lobe of the liver into a child recipient is carried out.

Auxiliary Liver Transplantation

Although orthotopic liver transplantation provides a means of rapidly restoring liver function in patients with acute liver failure, it carries with it two significant disadvantages:

1. The need for life-long immunosuppression
2. The elimination of the possibility that the native liver may spontaneously regenerate.

These are circumvented by auxiliary liver transplantation, in which an additional segment of liver is implanted to provide temporary support.

Nowadays, a part of the native liver is replaced with an equivalent section of donor organ. This is called auxiliary partial orthotopic liver transplantation (APOLT). This technique has been found useful in Crigler-Najjar syndrome.

Split Liver Transplantation

One cadaver organ can be split between two recipients—adult and one child.

Adult receives right lobe and the child receives left lobe of cadaver liver.

Bioartificial Liver

This newly invented technique has been used in patients with acute liver failure as a bridge until the native liver regenerates or until a donor organ becomes available.

Systems using cultured human hepatocytes, that would have the capacity to remove toxins and provide synthetic functions have been employed.

Extracorporeal liver assist device (ELAD) uses cultured human hepatoblastoma cells grown in the extracapillary space of a hollow fibre dialyser. Venous blood is pumped through the fibres, leading to the ultrafiltration of plasma into the extracapillary space. Return of the ultrafiltrate to the patient allows the delivery of high molecular weight products including clotting factors.

Success Rate

Long-term survival is 60–80%.

Molecular Adsorbent Re-circulating System (MARS)

MARS is based upon the principle of albumin dialysis. It consists of three compartments – blood circuit, albumin circuit and renal circuit. Here the blood is dialysed against an albumin containing solution across a suitable membrane. The albumin bound toxins are potentially taken up by the binding sites of the dialysate albumin and thus removed from the blood.



Chapter 6

Haematology

SYMPTOMS

- FATIGUE
- BREATHLESSNESS
- PICA
- FEVER
- INTERCURRENT INFECTIONS
- JAUNDICE
- BLEEDING MANIFESTATIONS (gum bleeding, petechiae, purpura)
- BONY PAIN
- DYSPHAGIA

SIGNS

- Chipmunk facies
- Pallor
- Angular stomatitis
- Glossitis
- Koilonychia
- Jaundice
- Enlarged tonsils
- Generalised lymphadenopathy
- Skin nodules/ulceration
- Gum hyperplasia/bleeding
- Purpura
- Signs of cardiac/renal failure
- Hepatomegaly and Splenomegaly
- Abdominal lymphadenopathy
- Testicular enlargement
- Signs of peripheral neuropathy
- Features of subacute combined degeneration of cord
- Fundus examination
- Meningism

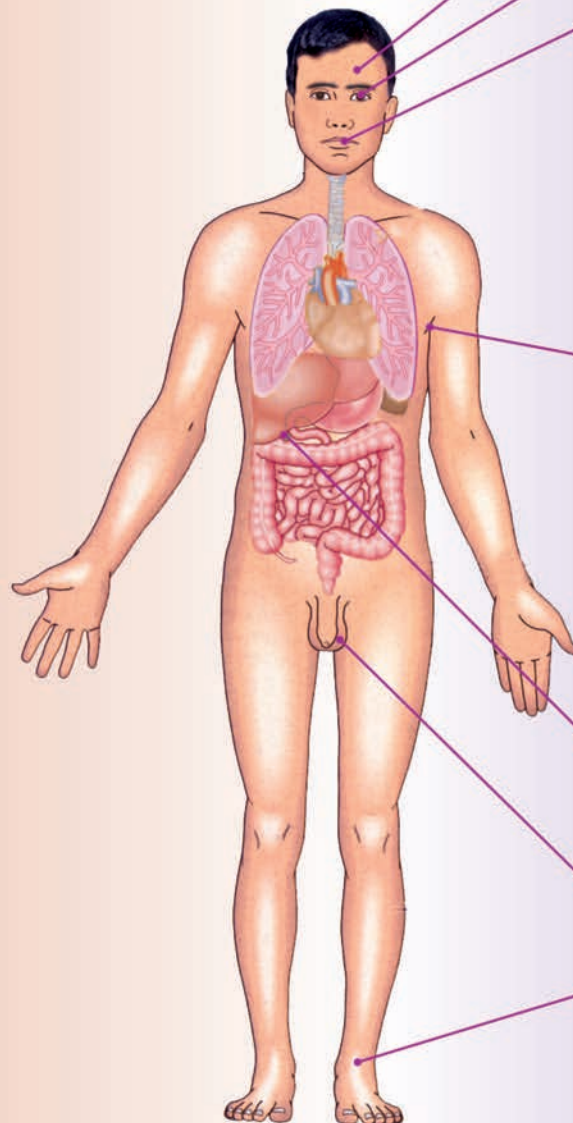

Haematopoiesis and Haematopoietic Growth Factors

Proliferation of the early haematopoietic cells occurs as the embryo grows and becomes a foetus (10-12 weeks). During early foetal life, after the sixth week of pregnancy upto the second trimester, the liver and the spleen are the major sites for haematopoiesis. The sites of haematopoiesis gradually shift from the liver and spleen to the medullary cavities of the bones. At birth, virtually medullary cavities of every bone contribute to this proliferative process. Pluripotential cells remain in other organs of the reticuloendothelial system as haematopoietic "rest cells." These give rise to extramedullary haematopoiesis when there is a demand.

Haematopoietic Stem Cells

These are a unique clone of cells capable of differentiating into the multiple cell lines of the haematopoietic system (Fig. 6.1). Stem cell proliferation is under direct influence of haematopoietic growth factors present in the reticuloendothelial system.

Haematopoietic Stem Cell Differentiation

Name of the cell	Function
Erythrocytes	Hb present in the erythrocytes helps in the O ₂ and CO ₂ transport mechanism of blood; it has a minor role in the acid-base balance.
Neutrophils	These are phagocytes capable of ingesting bacteria and fungi by chemotaxis and opsonisation. The bacteria are killed by O ₂ dependent (H ₂ O ₂ production, myeloperoxidase release) and O ₂ independent (lysozyme, lactoferrin release, and reduction of pH in the phagosome) mechanisms. They also produce transcobalamin III, a vitamin B ₁₂ binding protein which increases in leukaemia. They liberate tissue damaging substances after ingestion of uric acid crystals.
Eosinophils	These are weakly phagocytic and are associated with allergic reactions. They ingest antigen-antibody complexes and can process foreign proteins. They also have a role in the containment of parasitic infestation.
Basophils	These are poor phagocytes and can bind to IgE molecule. Degranulation of basophils can occur with release of histamine (type I hypersensitivity). They also contain heparin which participates in the metabolism of lipids.
Monocytes	These are phagocytic and constitute the monocyte-macrophage system which removes debris as well as micro-organisms by phagocytosis; they help in the collection and presentation of antigenic material to the lymphocytes. They help in the lysis of tumour cells. They also produce IL-I and TNF and other mediators

of acute phase reaction. They produce platelet derived growth factor and helps in healing and tissue remodelling. Tissue thromboplastin is produced in response to bacterial endotoxin, thereby activating extrinsic coagulation pathway leading to intravascular coagulation.

Lymphocytes

These arise from committed stem cells of the marrow and migrate to thymus (T-cells). Others become B-cells (bursa of fabricius in birds). A few become null cells. T-cells are involved in cell mediated immunity. B-cells are involved in humoral immunity by producing antibodies.

Thrombocytes (platelets)

They respond quickly to ADP, thrombin and collagen and adhere to vascular subendothelium by becoming spherical. There are three types of storage granules. α granules contain fibrinogen, vWF. Dense granules contain ADP and serotonin. They also have lysosomes which contain acid hydrolases. The release of contents causes platelet aggregation and fibrin deposition on the platelet surface. On activation, platelets release arachidonic acid which results in the formation of thromboxane A₂ which in turn stimulates platelet aggregation.

Nature of the Marrow Stem Cell

- Renewal capacity
- Great proliferative and differentiative potential
- Gives rise to all lympho-haematopoietic lineages
- Relatively quiescent but cycling population—easily induced into cell cycle
- Potential for giving rise to variety of non-haematopoietic cells.

Stem Cell Diseases

- Acute myelocytic leukaemia
- Chronic myelogenous leukaemia
- Myelofibrosis and myeloid metaplasia
- Polycythaemia rubra vera
- Aplastic anaemia
- Cyclical neutropenia
- Paroxysmal nocturnal haemoglobinuria

Therapeutic Application of Stem Cells

- Restoration of haematopoiesis after ablative chemoradiotherapy
- Treatment of marrow disorders like aplastic anaemia
- Treatment of immunodeficiency diseases
- Helps in the healing of chronic skin wounds
- Utilisation as a vehicle for gene therapy

Haematopoietic Growth Factors

These are heterogenous group of cytokines that stimulate progenitor cells of haematopoietic system and induce

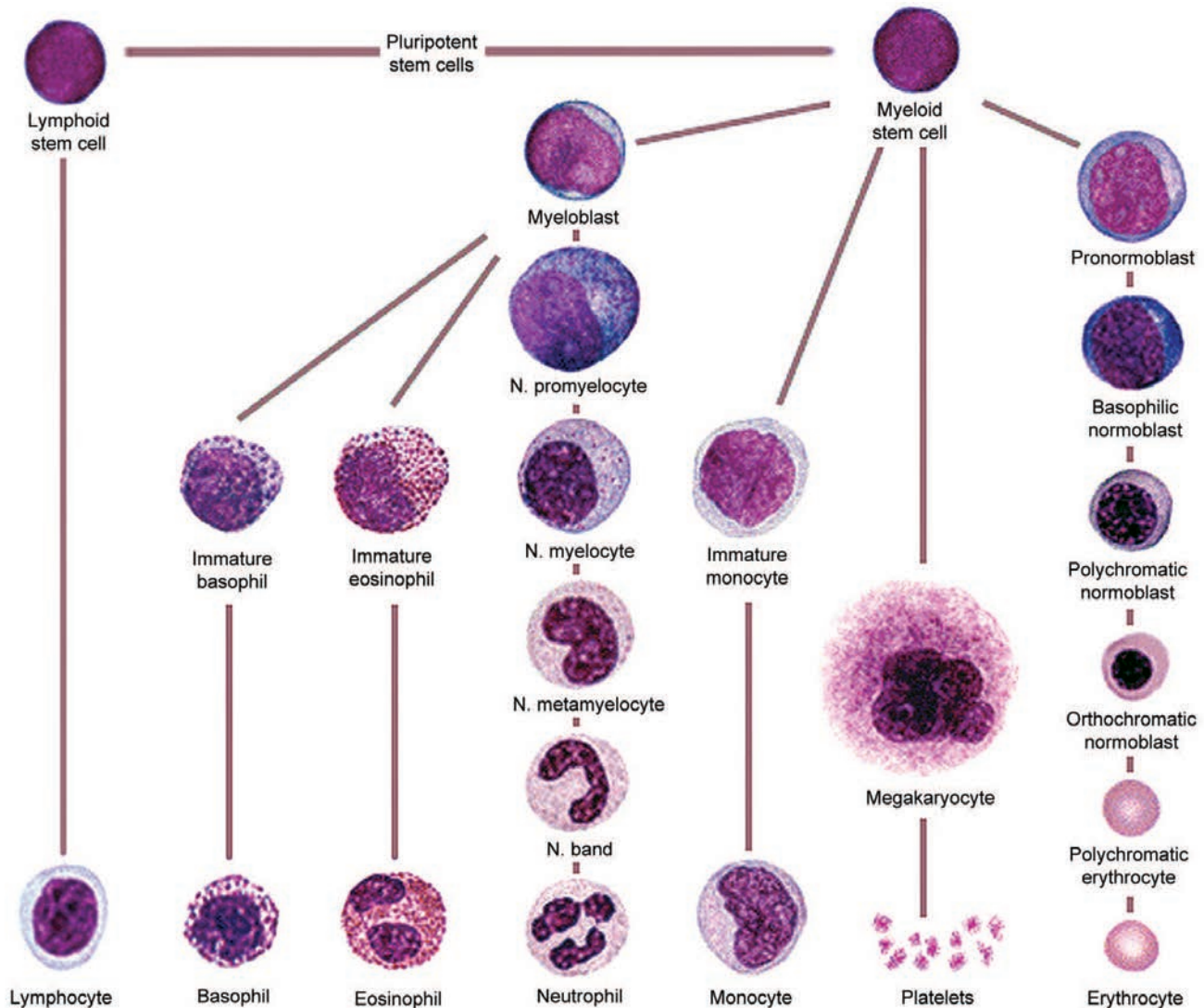

Fig. 6.1: Differentiation of haematopoietic cells

proliferation and maturation. These hormones play a critical role in the regulation of all haematopoietic cells in health and disease.

Major Growth Factors

1. **Erythropoietin:** This is synthesised by the peritubular cells of the kidney in response to hypoxaemia and is always present in minute amounts in human urine. About 10% of endogenous erythropoietin is secreted by the liver. The plasma half-life of erythropoietin in anaemic patients is 6-9 hours, and it shortens with continued therapy. The gene coding for erythropoietin is located on chromosome 7 (C_7 , q11-22).
Normal serum level is 10 to 25 IU/L.
2. **Interleukin (IL-3):** T-lymphocytes produce IL-3, and this factor is not lineage specific. IL-3 appears to stimulate production and renewal of the pluripotent stem cell compartment, and for its differentiation into all myeloid cell lines and lymphocytes. The gene coding for IL-3 is located on chromosome 5 (C_5 , q23-31).
3. **Granulocyte macrophage colony-stimulating factor (GM-CSF):** GM-CSF is synthesised and secreted by bone marrow stromal cells, fibroblasts, T-cells, and endothelial cells. GM-CSF stimulates the growth of progenitors of granulocytes, monocytes, and erythrocytes, and often causes eosinophilia as well. It activates granulocytes and monocytes/macrophages

Other Cytokines Affecting Hematopoiesis

Cytokines	Gene locus	Function
IL-1		Endogenous pyrogen, induces production of other cytokines from other cells, Co-stimulates stem cells, modulates immune response
IL-2		T-cell growth factor, inhibits myelopoiesis
IL-3		Stimulates multiple haematopoietic lineages
IL-4		Stimulates B-cells and modulates immune response
IL-5 or B-cell stimulating factor-2		Potent eosinophil-differentiation factor; causes a rise in peripheral eosinophils
IL-6		Major mediator of inflammation and immune response; important growth factor for myeloma cells
IL-7	Long arm of chromosome-8	Important growth and differentiation factor for T-cells; acts synergistically with IL-2 and IL-6
IL-8	Long arm of chromosome-4 (C ₄ q)	A potent chemotactic activating factor for neutrophils and also for T-cells and eosinophils
IL-9	Chromosome-5 (C ₅ q31)	Acts synergistically with IL-4 to potentiate antibody production by B-cells
IL-10	Chromosome-1	Potent immunosuppressant of macrophage function and down regulates MHC class II antigen expression on macrophages
IL-11		An inflammatory mediator stimulating the synthesis of hepatic acute phase reactants
IL-12		Produces gamma interferon (IFN- γ) from T-cells and NK cells and helps in the differentiation of helper T-cells
IL-13	—	Similar in action to IL-4 on B-cells and monocytes, induces production of IFN- γ by large granular lymphocytes and stimulates T-cells
IL-14	—	Induces B-cell proliferation and inhibits immunoglobulin synthesis
IL-15	—	Shares activity with IL-2, facilitates IFN- γ and TNF- α production along with IL-12, stimulates proliferation of activated T-cells, NK cells and masT-cells.
IL-16	—	CD 4 + T-cell chemattractant and growth factor stimulator.

IL-17	—	Stimulates adherent T-cell types like macrophages to secrete various cytokines, induces T-cell proliferation, stimulates granulopoiesis.
IL-18	—	Similar to IL-12, augments CMI, modulates T,B and NK cells function, induces IFN- γ in type 1 helper T and NK cells.
Stem cell factor (SCF)		Promotes masT-cell proliferation along with IL-3 and IL-4
IL-19		Induces IL-6 and TNF- α and cellular apoptosis
IL-20		Keratinocyte proliferation
IL-21		Myeloma cell survival factor, T and NK cell regulation
IL-22		IL-10 homolog, acute phase production by hepatocytes
IL-23		Autoimmune inflammation of the brain, overlaps with IL-11 and 12
IL-24		Tumour apoptosis
IL-25		Lymphoid cell proliferation, induces IL-4, IL-5, and IL-13
IL-26 to 29		Identified and under evaluation

and enhances phagocytosis and other functions of these cells.

4. *Granulocyte colony-stimulating factor (G-CSF)*: G-CSF is a potent, low-molecular-weight glycoprotein that stimulates proliferation and maturation of granulocyte precursors. This factor is produced by stromal cells, monocytes, macrophages, and endothelial cells. Within 48 hours after administration, the number of circulating neutrophils dramatically increases. The effect is lineage specific and dose-dependent. The gene coding for G-CSF is located on chromosome 17 (C₁₇, q11-21).
5. *Macrophage colony-stimulating factor (M-CSF)*: M-CSF is secreted by stromal cells, macrophages and fibroblasts. It is a potent stimulator of macrophage function and activation resulting in stimulation and elaboration of other cytokines resulting in increased expression of MHC class II antigen on macrophages and enhanced cytotoxicity. There is a slight to moderate rise in white blood cells after its administration. The gene for M-CSF is located on chromosome 5 (C₅, q33).
6. *Interleukin-2 (IL-2) or T-cell growth factor (T-CGF)*: IL-2 is synthesised and secreted by activated T-cells, primarily helper-T cells. IL-2 leads to clonal expansion of antigen-specific T-cells and the induction of the



expression of IL-2 receptors (CD₂₅) on the surface membrane of T-cells. It induces non-MHC restricted cytotoxic lymphocytes. It also stimulates proliferation of NK cells and B-cells.

7. *Interleukin-4 (IL-4) or B-cell stimulating factor (BSF-1)*: This is a potent growth factor derived from activated T-cells and mast cells. IL-4 induces the proliferation and differentiation of B-cells and the expression of MHC class II antigens on resting B-cells. IL-4 can also activate T-cells, monocytes/macrophages, mast cells, fibroblasts, and endothelial cells.
8. *Thrombopoietin*: This is the major regulator of megakaryocyte proliferation, differentiation, and platelet production. It stimulates and supports the survival of primitive stem cells.

These cytokines may be important in contributing to the delicate balance and regulation of haematopoiesis. Through recombinant DNA technology, many of these cytokines have become available in sufficient quantities to allow clinical studies to be performed.

Commercially Available Haematopoietic Growth Factors and their Clinical Uses

Factor	Clinical uses
Recombinant human granulocyte-macrophage colony-stimulating factor	Acceleration of myeloid recovery in patients with non-Hodgkin's lymphoma, ALL or Hodgkin's disease who are undergoing autologous BMT
Recombinant human granulocyte colony-stimulating factor	Neutropenia in non-myeloid malignant disease in patients receiving myelosuppressive drugs or chemotherapy
Recombinant human erythropoietin	Anaemia of chronic renal disease (in dialysis-dependent patients)
Interleukin-2	Advanced renal cell carcinoma
IFN- α	Early stage CML, hairy cell leukaemia, mycosis fungoides, Sezary syndrome, malignant melanoma, multiple myeloma, HTLV 1 associated leukaemia or lymphoma
IFN- β	Relapsing remitting multiple sclerosis,
IFN- γ	Graft versus host disease, Chronic granulomatous disease, Idiopathic pulmonary fibrosis
IL-11	Chemotherapy induced thrombocytopenia
Thrombopoietin	Thrombocytopenia
TNF- α	Used in isolated limb perfusion in sarcoma and melanoma
Keratinocyte growth factor (KGF)	Human recombinant KGF decreases gut GVHD by preserving graft versus leukaemia effect. May be used in wound healing and prostate cancer
Monocyte/macrophage CSF	May be used in renal cell carcinoma, melanoma and severe fungal infections
Stem cell factor	Haematopoietic progenitor stimulation, mobilisation of stem cells when used along with G CSF and in aplastic anaemia

Normal Reference Values in Haematology

1. Haemoglobin and Haematocrit

Age	Hb g/dl	Hct
Birth	17	52
Childhood	12	36
Adult		
Man	16 \pm 2	47 \pm 6
Woman	14 \pm 2	42 \pm 6
Pregnant	12 \pm 2	37 \pm 6

2. Mean corpuscular volume (MCV)

$$\frac{\text{Hct} \times 10}{\text{RBC count} \times 10^6} = 90 + 8 \text{ fl}$$

3. Mean corpuscular haemoglobin (MCH)

$$\frac{\text{Hb g/dl} \times 10}{\text{RBC count} \times 10^6} = 30 + 3 \text{ pg}$$

4. Mean corpuscular haemoglobin concentration (MCHC)

$$\frac{\text{Hb g/dl} \times 10}{\text{Hct}} \quad \text{OR} \quad \frac{\text{MCH}}{\text{MCV}} = 33 + 2\%$$

5. Mean corpuscular diameter

Mean corpuscular diameter of 50 cells in smear = 7.5 μ (Male and Female)

6. RBC count

Male 4.5 to 5.5 millions/mm³
Female 4 to 4.5 millions/mm³

7. RBC life span

120 days (100 – 120)

8. Red cell distribution width

RDW = 11 to 16

9. Reticulocyte count

Male 1.6 + 0.5%
Female 1.4 + 0.5%

Absolute Reticulocyte Count

Absolute Reticulocyte Count = % of reticulocytes \times RBC count/mm³

An increase in reticulocytes to greater than 100,000/mm³ suggests a hyper-proliferative bone marrow associated with loss or destruction of RBCs.

Anaemia with low reticulocyte count suggests impaired RBC production.

Reticulocyte Index*

$$\% \text{ of reticulocytes} \times \frac{\text{Observed Hct}}{\text{Normal Hct}} \times \frac{1}{2}$$

(*Reticulocyte percentage can be corrected for the reduction in red cell counts in anaemia by multiplying the percentage with the ratio of observed Hct to normal

Hct. This corrected reticulocyte percentage can further be adjusted by taking into account in anaemia there is premature release of reticulocytes and a correction will entail dividing the corrected reticulocyte % by 2 termed as reticulocyte index.)

Peripheral Film Morphology (Fig. 6.2)

- Acanthocytes/Spur cells*: RBC shows many irregular spicules—E.g. Abetalipoproteinaemia
- Anisocytosis*: Variations in the size of RBCs—E.g. Iron deficiency anaemia, Megaloblastic anaemia, Thalassaemia
- Poikilocytosis*: Variations in the shape of RBCs—E.g.
 - Hypochromia*: Less stained RBCs—E.g. Iron deficiency anaemia, Sideroblastic anaemia
 - Microcytosis*: Small sized RBCs < 75 fl—E.g. Iron deficiency anaemia, Thalassaemia, Congenital sideroblastic anaemia
 - Macrocytosis*: Increased size RBCs— MCV > 100 fl— E.g. B₁₂ or Folate deficiency anaemia
 - Dimorphic picture*: Combination of microcytosis and macrocytosis—E.g. Partially treated iron deficiency anaemia, mixed deficiency of Fe, folate or B₁₂, Post-transfusion, Sideroblastic anaemia

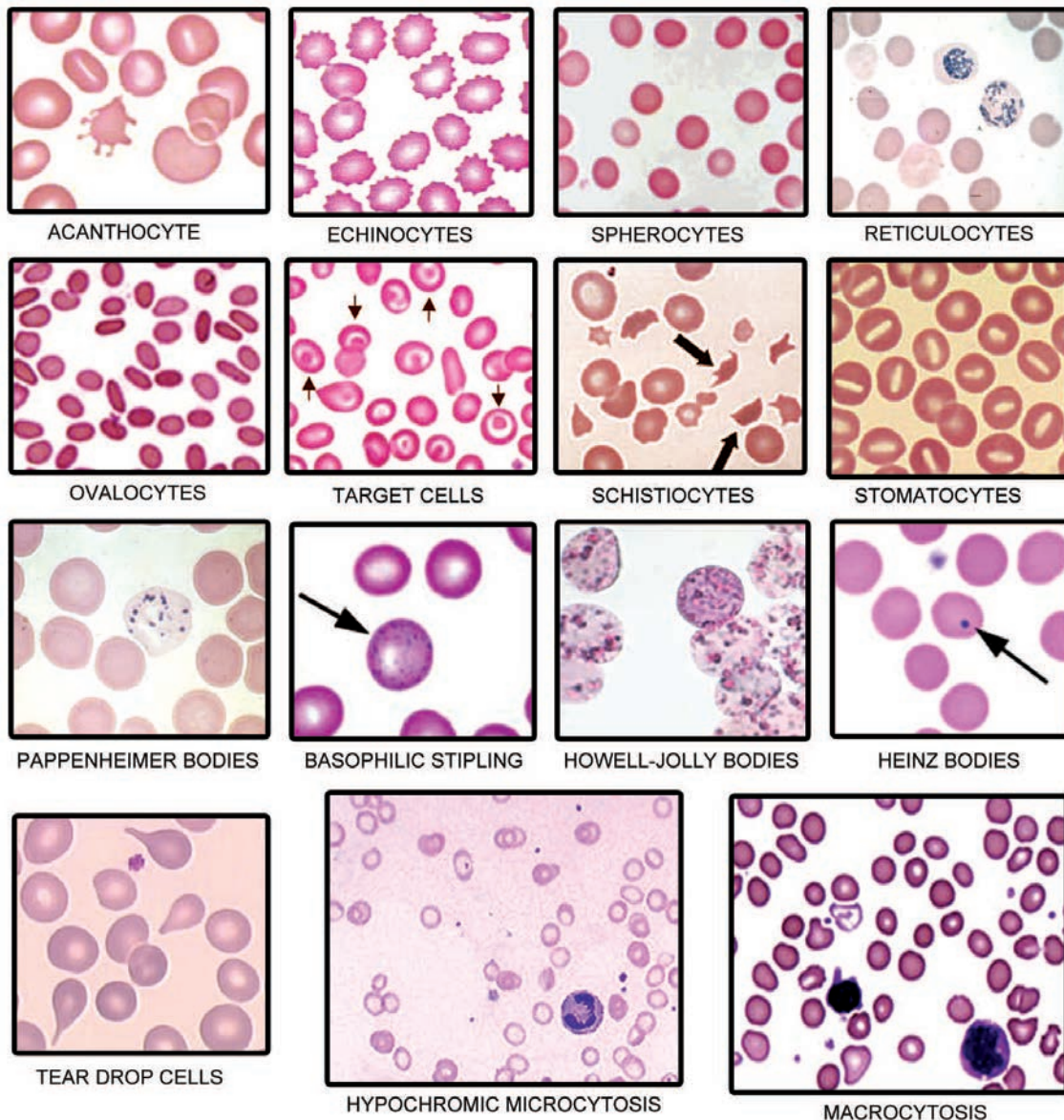

Fig. 6.2: Morphology of RBCs in peripheral smear



- h. *Burr cells*: Regularly placed spines in RBCs—E.g. Uraemia
- i. *Schistocytes*: Fragmented RBCs—E.g. Intravascular haemolysis
- j. *Basophilic stippling*: Speckling of RBCs with fine dots on basic staining—E.g. Lead poisoning, Thalassemia, Dyserythropoietic anaemias
- k. *Howell Jolly bodies*: Nuclear remnants seen in RBCs—E.g. Post-splenectomy, Hyposplenism, rarely in leukaemia, iron deficiency anaemia, megaloblastic anaemias
- l. *Heinz bodies*: Precipitated haemoglobin in RBCs—E.g. Unstable haemoglobins, oxidation stress
- m. *Spherocytes*: Small densely stained RBCs with loss of central pallor—E.g. Hereditary spherocytosis, Immunohaemolytic anaemias
- n. *Target/Mexican hat cells*: RBCs with a dark centre surrounded by a light band which is again encircled by a darker ring—E.g. Thalassemia, Hb S and C, Liver disease
- o. *Pappenheimer bodies*: Granules of siderocytes – E.g. Lead poisoning, Carcinomatosis, Post-splenectomy
- p. *Reticulocytes*: Young RBCs with a network of precipitated basophilic substance denoting active blood regeneration.
- q. *Stomatocytes*: Cup shaped RBCs having a slit like central zone of pallor due to lack of RBC membrane protein 7.2 (stomatins) and Rh proteins.

WBC Count

Total count—4000—11000 cells/cmm

Differential count:

Polymorphs—40–75% ($2.2-8.6 \times 10^3/\mu\text{L} = 2,200-8,600$)

Lymphocytes—20–45% ($0.8-3.5 \times 10^3/\mu\text{L} = 800-3,500$)

Monocytes—2–10% ($0.2-0.8 \times 10^3/\mu\text{L} = 200-800$)

Eosinophils—4–5% ($0.04-0.5 \times 10^3/\mu\text{L} = 40-500$)

Basophils—0–1% ($0.01-0.12 \times 10^3/\mu\text{L} = 10-120$)

ESR

Male—0–20 mm/hour

Female—0–30 mm/hour

Automated Full Blood Analysis

Causes of Spurious Results

Result	Conditions
Increased haemoglobin	Lipaemia, Jaundice, very high WBC count
Decreased haemoglobin	Blood collection while an infusion flowing, Improper sample mixing
Increased MCV	Non-ketotic hyperosmolality, Cold agglutination
Increased WBC count	Presence of nucleated RBCs
Decreased platelet count	Platelet clumping or satellitism, Clots in sample

Anaemia

Anaemia may be defined as a state in which the blood haemoglobin level is below the normal range for the patient's age and sex (Males < 12 g/dL; females < 10 g/dL).

WHO Definition

Male < 13 g/dl

Female < 12 g/dl



Causes of Anaemia

1. Decreased or ineffective marrow production
 - a. Inadequate iron, B₁₂ or folate, trace elements (zinc, cobalt)
 - b. Hypoplasia of bone marrow
 - c. Infiltration by malignant cells.
2. Peripheral causes (increased RBC destruction or loss)
 - a. Blood loss
 - b. Haemolysis
 - c. Hypersplenism.

Practical Classification of Anaemia

Microcytic Anaemias (MCV < 80 fL)

- Iron deficiency anaemia
- Thalassemia
- X-linked sideroblastic anaemia
- Lead poisoning
- Rheumatoid arthritis
- Hodgkin's lymphoma
- Myelofibrosis with myeloid metaplasia

Macrocytic Anaemias (MCV > 100 fL)

- B₁₂/Folate deficiency
- Myelodysplastic syndrome
- Liver disease
- Reticulocytosis
- Hydroxyurea treatment
- Excess alcohol intake

Normocytic Anaemias (MCV 80–100 fL)

Intrinsic causes:

- Idiopathic aplastic anaemia
- PNH associated aplastic anaemia
- Ineffective erythropoiesis—MDS and CMD
- Congenital dyserythropoiesis (CDA types I, II, III)

Extrinsic causes:

- Renal insufficiency
- Endocrine disorders

- Anaemia of chronic disease
- Immune mediated red cell aplasia
- Marrow infiltrative disorders
- Haemolytic anaemias
- Drug associated
- Toxin associated
- Radiation associated.

Classification

Classification of anaemia is based on reticulocyte index.

Reticulocyte Index < 2.5

Maturation Disorder

In maturation disorder, the defect is either in the cytoplasm or in the nucleus. The end result is either microcytosis or macrocytosis.

Cytoplasmic Defect (Microcytic-hypochromic)

- Iron deficiency
- Thalassaemia
- Sideroblastic anaemia

Nuclear Defects (Macrocytic-Hyperchromic)

- Folate deficiency
- Vitamin B₁₂ deficiency
- Drug toxicity
- Refractory anaemia

Hypoproliferative Marrow

It results in normocytic-normochromic anaemia.

Marrow damage:

- Infiltration
- Fibrosis
- Aplasia

Decreased stimulation:

- Inflammation
- Metabolic defect
- Renal disease

Reticulocyte Index > 2.5

Haemorrhage

Blood loss

Haemolysis

- Membrane abnormality
- Haemoglobinopathy
- Intravascular haemolysis
- Autoimmune defect

- Fragmentation haemolysis
- Metabolic defect

In the presence of anaemia

1. *Normal MCV* suggests anaemia of acute loss or chronic disease (normocytic-MCV between 78 to 98 fL).
Causes: Chronic disease, bone marrow failure, haemolysis, hypothyroidism, renal failure and pregnancy.
2. *Low MCV* suggests iron deficiency or thalassaemia (microcytic-around 75 fL).
Causes: Iron deficiency, thalassaemia, congenital sideroblastic anaemia.
3. *High MCV* suggests B₁₂ or folate deficiency (macrocytic-MCV > 100 fL).
Causes: B₁₂ and folate deficiency, alcoholic liver disease, reticulocytosis, marrow infiltration, hypothyroidism.

Symptoms and Signs

The clinical presentation of anaemia depends on the rapidity with which anaemia develops and the pathological mechanism behind it.

- a. *Chronic progressive anaemia:* Lassitude, fatigue, loss of stamina, breathlessness, tachycardia, pallor of skin and mucous membrane, and signs of cardiac failure in severe anaemia including cardiac dilatation, systolic flow murmurs, oedema etc.
- b. *Blood loss anaemia:* Hypovolaemia dominates the clinical picture.
10–15% loss—Vascular instability
> 30% loss—Postural hypotension and tachycardia
> 40% loss—Hypovolumic shock, confusion, dyspnoea, diaphoresis, tachycardia, hypotension.
- c. *Haemolytic anaemia:* Acute back pain due to intravascular haemolysis, haemoglobinuria, signs of renal failure.

Iron Deficiency Anaemia

Haemoglobin is normally the largest iron compartment of the body. Hb is 0.34% iron by weight. In an adult, total iron content of Hb compartment is about 2 gm.

Haemoglobin at birth is about 20 gm/dl and it gets reduced to 10 gm/dl at 3 months of age. In males, normal Hb level is about 14 gm/dl and in females about 12 gm/dl.

Iron Metabolism

Iron taken in diet is absorbed at all parts of GI tract especially duodenal mucosa. Acid medium favours iron absorption. Acid medium favours formation of soluble

macromolecular complexes of iron with vitamin C, sugar, amino acid or bile in the duodenum. Only 10% of the ingested iron is absorbed.

Normal serum iron level is 50 to 150 mg/dl.

Frank iron deficiency increases absorption by 30- 40% and in iron overload, absorption decreases.

Iron absorption is increased in (1) ferrous state, (2) increased erythropoiesis (3) iron deficiency.

Iron absorption is decreased in (1) ferric state, (2) in the presence of phosphates and phytates, (3) bone marrow hypoplasia.

The absorbed iron is stored in the form of ferritin (water soluble form) and haemosiderin (water insoluble form). In men, storage compartment contains about 1000 mg of iron and in women, it ranges from 0-500 mg; In one-third of healthy women, there is no significant iron in storage compartment. The storage organs are liver, spleen, lymph nodes and bone marrow.

Iron is transported after binding with transferrin, a cytoplasmic protein. Transport iron compartment contains 3 mg of iron. Transferrin concentration in plasma is measured by estimating total iron binding capacity or immunologically.

Normally 1 mg of elemental iron is lost from shedding of senescent cells of gastrointestinal tract and genitourinary tract, and from desquamation of skin.



Causes of Iron Deficiency (Fig. 6.3)

1. Increased iron utilisation (increased demand)
 - Postnatal growth spurt
 - Adolescent growth spurt
 - Erythropoietin therapy
2. Physiologic iron loss
 - Menstruation
 - Pregnancy
3. Pathologic iron loss
 - Gastrointestinal bleeding
 - Genitourinary bleeding
 - Pulmonary haemosiderosis
 - Intravascular haemolysis
 - Phlebotomy for polycythaemia rubra vera
4. Decreased iron intake
 - Cereal rich diet
 - Pica, food fads, malabsorption
 - Acute or chronic inflammation.

Physiological Causes

In children, iron available during birth is adequate for erythropoiesis till 3 to 4 months and later weaning food

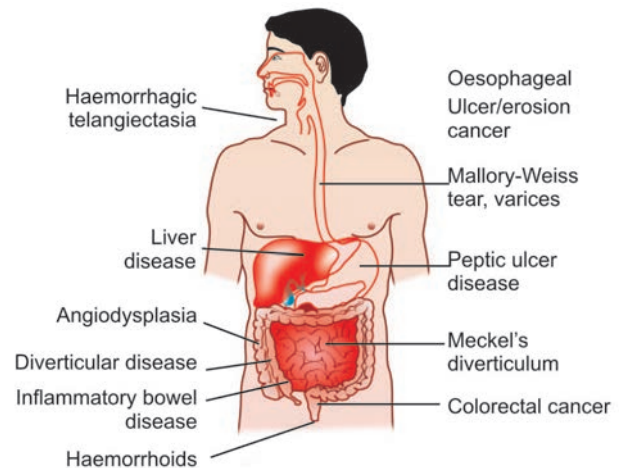

Fig. 6.3: GIT causes for iron deficiency anaemia

rich in iron should be substituted. If weaning is delayed, anaemia develops.

Prematurity and haemorrhage from the cord at birth deprive the infant of normal iron store.

In adolescents, iron deficiency occurs during growth spurt and also occurs because of food fads.

In Adults (Menstruating Women)

Menstruation causes an average loss of 30 mg of iron per month.

In pregnancy, there is no menstrual loss. However, additional iron is needed for the foetus, the placenta, and for the increased red cell mass and for the blood loss during delivery.

Iron requirement in males	1 mg per day
Iron requirement in females	2 mg per day
Iron requirement in pregnancy	3 mg per day

In Post-menopausal Women and Adult Men

Most common cause of iron deficiency in this group is gastrointestinal bleeding (drug-induced gastritis, gastrointestinal malignancy, peptic ulcers).

At All Ages

Hookworm infestation, schistosomiasis, diet deficient in iron are causes of iron deficiency at all ages, especially elderly.

Stages in Iron Deficiency Anaemia

There are three stages in the development of iron deficiency anaemia.

- a. Negative iron balance
- b. Iron deficient erythropoiesis
- c. Iron deficiency anaemia.



Clinical Features

Patients may have angular stomatitis, atrophic glossitis, koilonychia, brittle hair, pruritus, pica, Plummer-Vinson syndrome (postcricoid web) or menorrhagia.



Investigations

1. *Haemoglobin level:* When Hb is greater than 10 gm/dl, symptoms of anaemia develop only on exertion or on exposure to hypoxia or high altitude. If Hb level is less than 7 gm/dl, patient is symptomatic even at rest. There is also loss of pigmentation in palmar crease (Fig. 6.4).
2. Microcytic, hypochromic (MCHC < 32%) RBCs in the peripheral smear.
3. Raised platelet count may suggest bleeding.
4. Perl's Prussian blue technique demonstrates empty iron stores in the bone marrow.
5. Serum ferritin level is low (first to reflect iron deficiency). It is often less than 12 mcg/L; values > 80 mcg/L, rules out iron deficiency anaemia (normal ferritin level-15 to 400 mcg/L).
6. *Iron absorption is increased and the total iron binding capacity rises.
7. Chromium labelled red cells may be used to measure blood loss into the gut.
8. RBC protoporphyrin is increased—> 200 µg/dl (normal value -30-50 µg/dl).
9. Serum levels of transferrin receptor protein is increased—(normal 4-9 µg/dl).

Note: *Serum iron, TIBC and transferrin saturation have a very limited diagnostic value since the results are

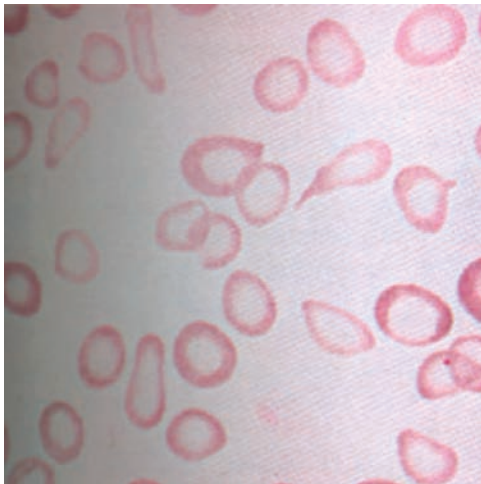

Fig. 6.4: Iron deficiency anaemia—hypochromic microcytes

variable during physiological conditions and during inflammatory diseases.



Differential Diagnosis

1. Anaemia of chronic disease
2. Thalassemias
3. Haemoglobinopathies (Hb E)
4. Chronic liver disease
5. Chronic renal disease
6. Myelodysplastic disorders (refractory anaemia with ringed sideroblasts)
7. Myeloproliferative disorders
8. Hereditary sideroblastic anaemia
9. Myxoedema
10. Congenital atransferrinaemia.



Management

1. Treat the underlying cause.
2. Iron replacement by ferrous sulphate 200 mg tds orally. 200 mg of ferrous sulphate contains 60 mg of elemental iron. Oral therapy is safest and cheapest. Avoid enteric coated and sustained release tablets. Haemoglobin rises by 1 gm/dl/week or by 1% per day (accompanied by a reticulocytosis). Continue until haemoglobin is normal and for 6-8 months to replenish stores. If there is no response to oral iron therapy, consider the following:
 - a. Incorrect diagnosis
 - b. Noncompliance
 - c. Blood loss exceeding rate of replacement
 - d. Marrow suppression by tumour, chronic inflammation
 - e. Malabsorption
 Other oral Fe preparations—Ferrous fumarate, ferrous gluconate, polysaccharide iron, carbonyl iron.
3. *Parenteral iron therapy:* It is given for those who are unable to absorb iron from the GI tract or to those who have intolerance to oral iron.

100 mg of iron (IM) are required to increase the haemoglobin level by 4% but the total dose of iron should not exceed 2.5 gm.
4. Alternative parenteral Fe preparations:
 - a. Sodium ferric gluconate—No test dose is needed. 125 mg in 100 ml of normal saline infused IV over 1 hour and not to exceed 250 mg/day. It is not given as single dose because of adverse reactions like hypotension.

Differential Diagnosis of Microcytic, Hypochromic Anaemia

Features	Iron-deficiency anaemia	β -thalassaemia trait	Anaemia of chronic disease	Sideroblastic anaemia
Serum iron	↓	Normal	↓	↑
TIBC	↑	Normal	↓	Normal
Serum ferritin	↓	Normal	↑	↑
Red cell protoporphyrin	↑	Normal	↑	↑ or Normal
Hb A ₂	↓	↑	Normal	↓

- b. Iron sucrose—100 mg in 100 ml of normal saline infused IV over 30 minutes and repeated 1-3 times/week.

Iron Requirement

Total dose = Hb deficit (gm/dL) × lean body weight (lb) + 1000 (mg of iron needed for storage).

Each 2 ml of iron dextran contains 100 mg of iron. A test dose of 0.5 ml should be given before therapy.

Iron Dextran-IV (In IM Intolerance)

500 mg of the compound is given with 100 ml of sterile saline; and infused after a test dose of 1 ml and if there is no adverse reaction.

Side effects are fever, chills, arthralgia, lymphadenopathy, splenomegaly, aseptic meningitis, anaphylactic shock, rarely sarcomas at the site of injection, and haemochromatosis.

In conditions simulating iron deficiency anaemia (β -thalassaemia, sideroblastic anaemia, anaemia of chronic disease), a therapeutic trial of iron should be given. It is half corrected in 3 weeks and fully corrected in three months in case of iron deficiency anaemia and not in the other conditions.

Oral iron therapy (200 mg tds) raises Hb by 1%

7 days of oral therapy raises Hb by 1 gm%

Parenteral iron (100 mg), raises Hb by 4%.

If the Hb deficit is 7 gm, oral iron replacement should be continued for at least 7 weeks; Therapy should be continued for 6 to 8 months for replacing iron stores.

Oral iron therapy is safest and cheapest. Avoid parenteral iron therapy unless it is strongly indicated.

With iron therapy, the reticulocyte count peaks in 5-10 days, and the Hb rises over 1-2 months.

Megaloblastic Anaemia

This term refers to abnormal haematopoiesis characterised by dys-synchronous nuclear and cytoplasmic maturation in all myeloid and erythroid cell lines due to aberrant DNA synthesis as a result of single

or combined deficiency of either cobalamin (Vit B₁₂) or folate.

Similar changes occur in other organs like uterine cervix, aerodigestive tract also and can be mistaken for carcinoma.

A MCV of > 100 fL should prompt the physician to go for further investigations.



Causes of Macrocytosis

1. MCV > 110 fL
Vitamin B₁₂ or folate deficiency.
2. MCV 100-110 fL
 - a. Alcohol
 - b. Liver disease
 - c. Hypothyroidism
 - d. Haemolysis
 - e. Pregnancy
 - f. Marrow infiltration
 - g. Myelodysplastic states
 - h. Drugs (zidovudine, azathioprine).



Causes of Vitamin B₁₂ Deficiency

1. Inadequate intake: Vegans (rare) pure vegetarians who do not consume milk and milk products.
2. Malabsorption:
 - a. Defective release of cobalamin from food
 - i. Drugs that block acid secretion
 - ii. Gastric achlorhydria
 - iii. Partial gastrectomy
 - b. Inadequate production of intrinsic factor (IF)
 - i. Pernicious anaemia
 - ii. Total gastrectomy
 - iii. Congenital absence of IF
 - iv. Functional abnormality of IF
 - c. Disorders of terminal ileum
 - i. Tropical sprue
 - ii. Non-tropical sprue
 - iii. Regional enteritis
 - iv. Intestinal resection

- v. Neoplasms
- vi. Granulomatous lesions
- vii. Selective cobalamin malabsorption
- d. Competition for cobalamin
 - i. Fish tapeworm (*Diphyllobothrium latum*)
 - ii. Bacteria (blind loop syndrome)
- e. Drugs – PAS, Neomycin, Colchicine
- f. Other rare causes
 - i. Nitrous oxide
 - ii. Transcobalamin II deficiency
 - iii. Congenital enzyme defects.

Metabolism of Vitamin B₁₂

1. Sources of vitamin B₁₂ are bacteria and animal tissue.
2. Serum level of vitamin B₁₂ is 200-600 pg/ml.
3. Requirement of vitamin B₁₂ is 1 mcg/day.
4. Total body store of vitamin B₁₂ is 5 mg. The storage lasts for 5 years. More than 50% is stored in the liver.
5. The ingested vitamin requires a gastric glycoprotein called intrinsic factor facilitating intestinal absorption, in the terminal ileum (distal 3-4 feet).
6. It is attached to a carrier protein (transcobalamin II) within the ileum and transported into the liver (major site of storage).

Transcobalamin I binds most of serum cobalamin and it has no physiological role.

Transcobalamin III is localised to specific neutrophil granules and the level of this carrier protein is increased in myeloproliferative disorders especially CML.

In pernicious anaemia, serum B₁₂ level is < 100 pg/ml.



Causes of Folate Deficiency

1. Dietary cause (poor intake of vegetables, elderly on tea and toasts, junk food anorexia nervosa, haemodialysis patients).
2. Malabsorption (alcoholism, celiac and tropical sprue, Crohn's disease, scleroderma, hypothyroidism).
3. Increased demand of folate-pregnancy, cell proliferation as in haemolysis, neoplasia, hyperthyroidism, ineffective erythropoiesis (pernicious anaemia, sideroblastic anaemia).
4. Drugs (phenytoin, methotrexate, trimethoprim, pyrimethamine, alcohol).

Folic acid deficiency may develop within a few months. Vitamin B₁₂ deficiency takes years to develop. Folate deficiency does not cause neurologic symptoms.

Metabolism of Folate

Normal folate requirement is 100 µg/d. Most dietary folate is available as polyglutamates. Green vegetables especially asparagus, spinach, lettuce, greenbeans are

good sources. However, cooking destroys non-protein bound folates found in these vegetables. Yeast and liver contain protein bound folates resistant to cooking.

Total body storage capacity is upto 5 mg (3-4 months supply).

Serum level of folate is 5-20 ng/ml. Folate is absorbed mainly in jejunum. 5-methyl tetrahydrofolate is the only physiologic form of circulating folate and is loosely bound to albumin. This is converted within the cell to tetrahydrofolate and to various co-enzyme forms. All cellular folate co-enzymes are polyglutamated forms of this vitamin.



Clinical Features

Pallor (lemon colour), smooth tongue, cardiac "hemic" systolic murmur, hepatomegaly, rarely splenomegaly. Neurologic picture in vitamin B₁₂ deficiency ranges from mental inattentiveness to severe mental confusion with or without dorsal and lateral column signs (subacute combined degeneration). However, some signs are not reversible with cobalamin therapy.



Investigations

1. Blood film shows hypersegmented polymorphs (B₁₂ deficiency-earliest sign; in folate deficiency > 5 lobes are present) (Fig. 6.5).

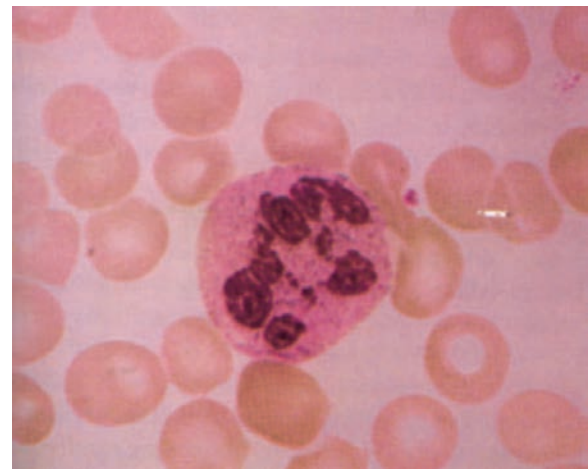

Fig. 6.5: Pernicious anaemia—macrocytosis with multilobed neutrophil

2. Increased ESR (malignancy)
3. Thyroid function tests
4. Serum B₁₂ level
5. Red cell folate level
6. Bone marrow biopsy
 - a. Megaloblastic—B₁₂ or folate deficiency (Fig. 6.6)

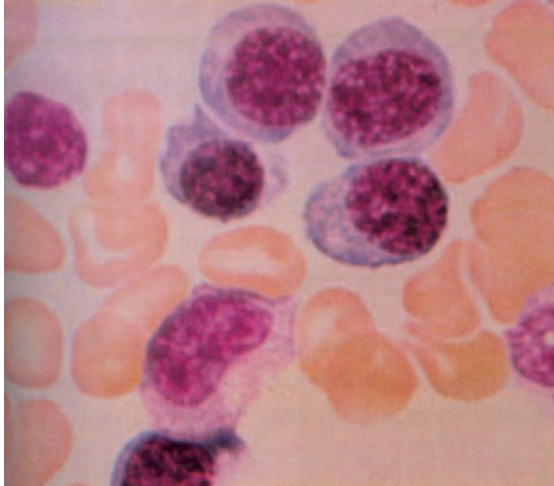

Fig. 6.6: Pernicious anaemia—megaloblasts in bone marrow

- b. Normoblastic—liver damage, myxoedema
 - c. Increased erythropoiesis—bleeding or haemolysis
 - d. Abnormal erythropoiesis—sideroblastic anaemia, leukaemia, aplastic anaemia.
7. *Schilling test*: It helps to identify the cause of B₁₂ deficiency. This determines whether a low B₁₂ is due to malabsorption or lack of intrinsic factor by comparing the proportion of an oral dose (1 mg) of radioactive B₁₂ excreted in urine with and without the concurrent administration of intrinsic factor. The blood must be saturated prior by giving an IM dose of 1000 mcg of B₁₂. If intrinsic factor increases absorption, the lack of it is likely to be the cause. If not, look for other causes like blind loops, diverticula and terminal ileal disease.

Beware of diagnosing pernicious anaemia before the age of 40 years and in younger age groups; most common cause would be GI malabsorption.

Useful Clues for Diagnosis

- Serum B₁₂ level less than 200 pg/ml.
- Serum folate level less than 4 ng/ml.
- RBC folate level is more diagnostic because it does not fluctuate frequently.
- Both homocysteine and methyl malonic acid serum values are increased in B₁₂ deficiency, but only homocysteine level is increased in folic acid deficiency (MMA normal level).

The presence of antibodies to intrinsic factor is diagnostic of pernicious anaemia.

Effects of B₁₂ and Folate Deficiency

Effects	B ₁₂ deficiency	Folate deficiency
Megaloblastic anaemia	Present	Present
Glossitis and Cheilitis	Present	Present
Intestinal malabsorption	Present	Present
Neurologic complications	Present	Absent
Elevated serum homocysteine	Yes	Yes
Elevated serum methylmalonic acid	Yes	No



Management

1. In B₁₂ deficiency, hydroxocobalamin 1000 mcg twice during the first week, then 1000 mcg weekly for a further 6 doses. Bone marrow shows a striking change within 48 hours; within 2 to 3 days the reticulocyte count begins to rise (> 50% in 10 days); 1000 mcg of cyanocobalamin per month for life-long should be given.

Rapid regeneration of the blood depletes the iron reserves of the body and hence ferrous sulphate 200 mg daily should be given soon after the commencement of treatment and the picture will be dimorphic then.

In combined deficiency, folic acid replacement alone worsens B₁₂ deficiency and hence it should not be given alone.

2. In folate deficiency 5 mg of folic acid/day orally is given. 5 mg once a week is given as maintenance therapy.

Folate supplements 350 mg daily is given for all pregnant women. In methotrexate therapy, to overcome the metabolic block, folinic acid 15 mg daily orally or as a IM/IV injection in a dose of 3 mg/ml are given.

3. Treat the intercurrent infections (UTI or respiratory infections).
4. When Hb level is < 5 gm/dl, transfusion therapy should be given (1 unit of packed red cells over 10-12 hours).

Hb increases by 1 gm/dL/week on specific therapy; WBC and platelet count should normalise within 1 week of therapy.

5. *Methylcobalamin*: It is the active co-enzyme of vitamin B₁₂. Oral methylcobalamin therapy is as effective as conventional injection therapy and useful for long-term management of vitamin B₁₂ deficiency and also in the treatment of autonomic and peripheral neuropathy. The dosage schedule can be 1,500 micrograms

PO/day for 7 days every 1-3 months or 500 micrograms/day for replacement therapy. The higher dose of 1-5 mg/day can be used in the management of diabetic, alcoholic, and chronic renal failure neuropathy.

In case, megaloblastic anaemias are not responsive to B₁₂ or folate, think of

1. Antineoplastic agent administration
2. Inborn errors of metabolism (hereditary orotic aciduria, inborn errors of folate metabolism)
3. Myelodysplastic syndromes.

With therapy, reticulocytosis should begin within one week, followed by a rise in Hb over 6-8 weeks.

Megaloblastic Disease without Anaemia

1. *Acute megaloblastic disease:*
 - It is seen following nitrous oxide anaesthesia
 - Any patients with serious illness requiring intensive care
 - Resembles immunocytopenias with decreased leukocytes and platelets without anaemia
 - Peripheral smear is normal but bone marrow is megaloblastic
 - They respond with B₁₂ and folate
2. *Cobalamin deficiency without anaemia:*
 - Seen in elderly due to folate fortification
 - Serum transcobalamin II levels decreased
 - Serum cobalamin levels may be normal or low
 - They respond with B₁₂.

Anaemia of Chronic Disease (ACD) (Sideropenic anaemia, simple anaemia)

This is mild and nonprogressive anaemia, occurring over a period of 3-4 weeks and remains static thereafter.

ACD is most often associated with chronic infections, inflammatory diseases, trauma, and neoplastic diseases.



Causes of ACD

1. Anaemia of chronic inflammation
 - a. Infection
 - b. Connective tissue disorders
 - c. Malignancy

There is disturbed iron metabolism and hypoferraemia despite normal body iron stores.

Interleukin-1, TNF- α and IFN- γ are inflammatory mediators, which play a major role in the pathophysiology of ACD by stimulating release of lactoferrin from granulocytes. There is diversion of iron from the

dynamic pool to the intracellular storage pool and an insufficient supply of iron for erythropoiesis in the bone marrow.

Interleukin-I: It suppresses erythropoietin production.

TNF- α : It suppresses response to erythropoietin in erythroid cells.

Hepacidin: It is a substance released from liver in the setting of inflammation, which causes decreased iron absorption and utilisation.

Hypoferraemia and disturbance in iron kinetics is the hallmark of ACD.



Clinical Features

The signs and symptoms are referable to the underlying disease. Anaemia is usually mild and non-progressive, rarely less than 9 gm/dL.

Anaemia of chronic inflammation: Anaemia is never severe. If it is severe, search for other causes like bleeding or drug-induced myelosuppression.

Anaemia due to renal disease: This is of normochromic and normocytic type. This is due to lack of secretion of erythropoietin and suppression of its production by toxins. Some patients have evidence of haemolytic jaundice due to defect in hexose monophosphate shunt pathway.

In addition to aluminium toxicity, iron deficiency resulting due to blood loss also aggravates anaemia.

In some forms of acute renal failure the correlation between anaemia and renal function is weaker. Patients with haemolytic uraemic syndrome have increased erythropoiesis in response to haemolysis despite renal failure requiring dialysis. Polycystic renal disease also has a similar degree of erythropoietin deficiency. By contrast, patients with diabetes mellitus have more severe erythropoietin deficiency for a given level of renal failure.

Anaemia due to hypometabolic states (Anaemia secondary to endocrine failure): This may be due to hypothyroidism (associated pernicious anaemia, menorrhagia), Addison's disease, hypogonadism, and panhypopituitarism.

Anaemia of liver disease: This can be normocytic or slightly macrocytic. Stomatocytes (increased membrane due to deposition of cholesterol and phospholipid) and target cells may be seen in the peripheral smear.

In alcoholics, there is direct suppression of erythropoiesis. Ringed sideroblasts may be seen (due to malnourishment). Haemorrhage, gastritis, varices, and duodenal ulcer may worsen anaemia.

Diagnosis of Hypoproliferative Anaemias

Tests	Iron deficiency	Inflammation	Renal disease	Hypometabolic states
Anaemia	Mild to severe	Mild	Mild to severe	Mild
MCV (fL)	60–90	80–90	90	90
Morphology	Microcytic	Normocytic	Normocytic	Normocytic
Serum Fe (µg/dl)	< 30	< 50	Normal	Normal
TIBC	> 360	< 300	Normal	Normal
Saturation (%)	< 10	10–20	Normal	Normal
Serum ferritin (µg/L)	< 15	30–200	115–150	Normal
Iron stores	0	2–4 +	1–4 +	Normal

Guidelines for Erythropoietin/Darbepoetin

Indication	Erythropoietin	Darbepoetin
Chemotherapy induced anaemia/MDS	40,000 U/week	100 µg/week
Anaemia due to renal failure	50–150 U/kg tiw	0.45 µg/kg/week
Anaemia in HIV infection	100–200 U/kg tiw	Not approved
Anaemia of chronic disease	150–300 U/kg tiw	Not approved
Anaemia-unwilling to accept transfusion or Anaemic individual undergoing major surgery	300 U/kg/d × 1–2 wk	Not approved

(tiw – thrice weekly)

Anaemia due to protein starvation: It occurs in elderly and in children with marasmus.

On re-feeding they develop anaemia. They also have deficiency of iron, folic acid and B₁₂.



Investigations

See Table above.



Management

- Anaemia resolves when underlying cause is treated.
- Anaemia of chronic inflammation is not responsive to haematinics like iron, folate, vitamin B₁₂.
- Anaemia is never severe and transfusion is rarely indicated.
- Anaemia of uraemia corrects dramatically after renal transplantation. Anaemia is proportional to azotemia (except in polycystic kidney disease). Recombinant human erythropoietin can be given to maintain haematocrit between 0.32 to 0.37. Hypertension and thrombosis are common after erythropoietin therapy. (See Table above).
- Treatment of anaemia secondary to endocrine failure is by giving appropriate hormone replacement.
- Anaemia of liver disease may improve with improvement in liver function.
- Anaemia associated with malignancy may improve with cytotoxic drugs.
- Epo level is not useful for diagnosis, but levels < 200 mU/mL suggests patients benefit from Epo. Higher doses of Epo is required to treat ACD than for the therapy of renal anaemia. If no response has been observed at 900 units/kg/week, further dose increase is unlikely to be effective.

Haemolytic Anaemia

Haemolysis is said to occur when the mean RBC survival is less than 120 days. If the bone marrow does not compensate sufficiently, haemolytic anaemia results.



Causes

Congenital

- Membrane abnormalities (hereditary spherocytosis, hereditary elliptocytosis, acanthocytosis, stomatocytosis, Hereditary pyropoikilocytosis)
- Haemoglobin abnormalities (thalassaemias, haemoglobin S, C, D)
- Red cell enzyme defects (G6PD, pyruvate kinase, hexokinase, glutathione reductase deficiency).

Acquired

- Immune
 - Isoimmune
 - Autoimmune

Warm antibody type (IgG)

Idiopathic, SLE, lymphoma, chronic lymphatic leukaemia, ovarian teratoma, Evan's syndrome, drugs-methyl dopa.

Cold antibody type (IgM)

Cold haemagglutinin disease, paroxysmal cold haemoglobinuria (PCH), mycoplasma pneumonia, lymphoma, infectious mononucleosis, SLE, viral infections, chronic lymphatic leukaemia.

Drug related

Drug adsorbed onto RBC surface: penicillin, cephalosporins

Immune complex mediated: sulphonamides, quinidine.

c. Alloimmune (antibodies acquired by blood transfusions, or pregnancy, directed against transfused RBCs).

2. *Nonimmune*

- Mechanical (artificial valves, burns, march haemoglobinuria)
- Infection (malaria, *Clostridium welchii*, bartonellosis)
- Drugs (sulfonamide, snake venom-viper, nitrofurantoin)
- Dyserythropoietic (paroxysmal nocturnal haemoglobinuria).

**Investigations**

- Blood film shows polychromasia, macrocytosis, spherocytes (hereditary spherocytosis), elliptocytes, sickle cells (sickle cell anaemia), target cells (thalassaemias).
- Direct Coombs' test:* This test identifies red cells coated with antibody and/or complement and a positive result usually indicates an immune cause for the haemolysis.
- Lifespan of RBC:* This is determined by chromium labelling and the major site of RBC breakdown may also be identified.
- Urinary haemosiderin:* The presence of this indicates chronic intravascular haemolysis.
- Other tests:* Increased serum bilirubin (never exceeds 6 mg%), increased LDH, decreased haptoglobin (absence of haptoglobin is a strong indicator of haemolytic disease and its presence does not exclude haemolysis) and increased urinary urobilinogen suggest haemolytic jaundice.

**Management**

- Treat the cause for both warm and cold AIHA.

Warm AIHA:

- Glucocorticoids – Prednisone 1 mg/kg. The response is seen in 10 days. On cessation of haemolysis, the dose of prednisone can be tapered over 2-3 months
- IV immunoglobulin is less effective than in ITP (40%)
- Splenectomy for steroid resistant AIHA.
- Rituximab 375 mg/m² IV weekly for 4 doses.

Idiopathic cold AIHA:

- Glucocorticoids and splenectomy are not useful.
- Rituximab is effective
- Warm RBC transfusion to 37°C
- Plasma exchange to remove offending IgM antibody.

Hereditary Spherocytosis (HS)

This is inherited as an autosomal dominant disorder. There is a qualitative and quantitative deficiency of vital skeletal proteins of RBC membrane namely spectrin and/or ankyrin.

There are defects in cytoskeletal proteins.

Ankyrin – 50% of patients

Protein 3 – 25% of patients

Spectrin – 25% of patients

Protein 4.2 – less often

Loss of normal spectrin of RBC membrane results in loss of lipids from the membrane leading to loss of surface area and altered RBC morphology. Hence, RBCs lose their normal biconcave shape and become spherocytic with a decrease in surface to volume ratio.

Ankyrin is a protein that links spectrin to protein 3. Other defects can be, deficient spectrin associated with impaired assembly of spectrin with protein 4.1.

**Clinical Features**

Mild anaemia (Hb 8-12 gm/dl), splenomegaly, gallstones, jaundice, growth retardation.

**Investigations**

- Presence of haemolytic state.
- Increased osmotic fragility of RBCs:* RBCs when exposed to a series of hypotonic saline solutions, haemolyse at higher salt concentration than do normal cells. When patient's blood is incubated at 37°C for 24 hours, glucose deprived cells exhibit increased osmotic fragility due to increased sodium influx.

Increased osmotic fragility is also seen in autoimmune haemolytic diseases, whereas increased resistance to haemolysis is seen in thalassaemia, iron deficiency and some forms of liver disorders.

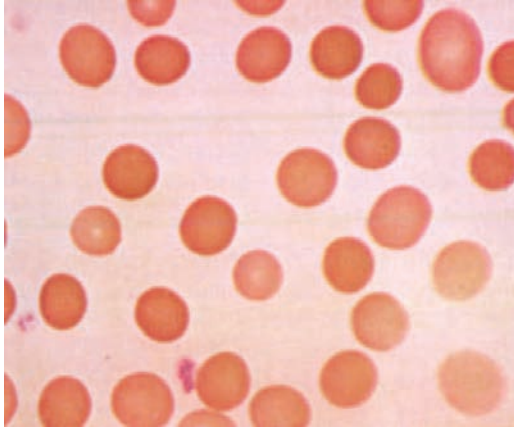

Fig. 6.7: Hereditary spherocytosis—spherical red cells without central pallor

3. Presence of spherocytes in the blood film (Fig. 6.7)
4. Increase in MCHC.



Management

1. *Splenectomy*: This is indicated
 - a. When anaemia causes health impairment
 - b. Haemolytic or aplastic crises (Parvovirus infection)
 - c. Family history of death from the same disease
 - d. Evidence of cholecystitis and cholelithiasis is present.

Pneumovax should be given 1-2 months prior to splenectomy.

Vaccine against haemophilus also should be given prior to splenectomy. Splenectomy is postponed upto 4 years of age to minimise the risk of serious infections.
2. Daily penicillin V, 250 mg 12 hourly is prescribed for at least 5 years following splenectomy.
3. Blood transfusion in severe haemolytic crises.
4. Folic acid 5 mg per day orally is prescribed to support the increased erythropoiesis.

Sickle Cell Disease

This is a haemolytic anaemia resulting from the homozygous inheritance of a gene which causes an amino acid substitution in the haemoglobin molecule (beta-6 glutamate → valine) creating HbS due to point mutation. It is common in black Africans and their worldwide descendants.

Classification

1. Homozygote (SS)—sickle cell anaemia

2. Heterozygote (AS)—sickle cell trait (protects from *falciparum* malaria).

Symptomatic sickling occurs in homozygotes. Heterozygotes are asymptomatic and present with mild anaemia except in situation of hypoxia, anaesthesia, when veno-occlusive events occur.

Factors Increasing Sickling

1. Low oxygen tension
2. Low pH
3. Increased 2, 3 diphosphoglycerate (2, 3 DPG)
4. Decreased RBC water content (increased serum osmolality)
5. Fever
6. Sluggish blood flow.

Pathogenesis

In the deoxygenated state, the HbS molecules polymerize and causes sickling of RBCs. Sickle cells are rigid, and haemolyse, and block small vessels to cause infarction. Deoxygenated Hb align in parallel forming tactoids that distort the RBC into the classic sickle and oak leaf shaped cells.



Clinical Features

Anaemia (Hb 6-8 gm/dl), reticulocytosis (10-20%), jaundice, painful swelling of hands and feet, and splenomegaly in the early stages (later autosplenectomy occurs) can occur. Chronic ill-health, renal failure, bone necrosis, infections, leg ulcers can result.



Complications

1. *Thrombotic crisis/infarction crisis*: Thrombosis occurs due to exposure to cold, dehydration, infection, ischaemia, fever, pregnancy, psychic stress, surgery, causing severe pain in the bones and other organs. It may simulate acute abdomen or pneumonia. Convulsions, focal neurological signs, priapism, hand foot syndrome (sickle dactylitis) proliferative retinopathy, leg and ankle ulcers, may also occur. *Salmonella* infection is common.
2. *Aplastic crisis*: This is usually due to parvovirus infection and is characterised by a low reticulocyte count.
3. *Sequestration crisis*: Due to RBC trapping, the spleen and liver enlarge. Anaemia becomes very severe which can be an acute manifestation and cause death in infants. Later, repeated infarction and fibrosis of

spleen leads to 'autosplenectomy'. Functional asplenia occurs much earlier (early childhood).

4. *Haemolytic crisis*: Rare.
5. *Acute chest syndrome*: Symptoms of chest pain, fever and cough with tachypnoea and arterial oxygen desaturation mimics pneumonia, pulmonary embolism or infarction. It is due to *in situ* sticking with the lung producing pain and dysfunction. Repeated episodes denote decreased survival.



Investigations

1. *Peripheral smear*: Shows Howell-Jolly bodies due to autosplenectomy, target cells, nucleated RBCs, RBC fragments, occasional thrombocytosis and leukocytosis.
2. *Hb electrophoresis at alkaline pH*: HbS can be detected by starch or agarose gel electrophoresis.
3. "*Sickle Prep*" test: This is performed by depriving RBCs of oxygen using metabisulphite or dithionite compounds as reducing agents and placing a coverslip over a drop of blood on a glass slide. The RBCs sickle *in situ*.

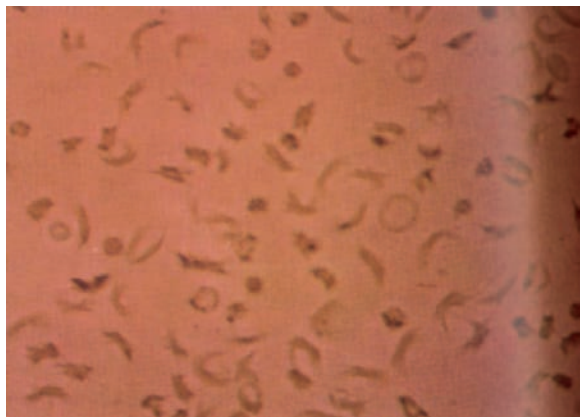

Fig. 6.8: Sickle cell anaemia—sickling due to sodium metabisulphite

Sickling is less in the presence of other haemoglobins like HbA₂, HbF.

Prevention

Antenatal tests are helpful for the diagnosis in the first and second trimester of pregnancy by using recombinant DNA technology. Amniocentesis, chorionic villous biopsy can be done as early as 7-10 weeks.



Management

1. *Infarction crisis*: Analgesia (sustained release morphine) IV fluids (100-200 ml/hr).

2. *Blood transfusion*: If PCV or reticulocytes fall sharply, in CNS or lung complications or when Hb level is < 6 gm/dL, blood transfusion can be given. If Hb level is > 9 gm/dL give a partial exchange transfusion.
3. Treatment of infection by antibiotics.
4. Oxygen through nasal prongs at a rate of 3-4 litres/minute to promote oxygenation at the pulmonary and arterial levels.
5. *Treat complications*
 - a. CNS complications—exchange transfusion
 - b. Acute splenic sequestration-exchange transfusion/splenectomy
 - c. Retinal lesions—exchange transfusion + long-term ophthalmic follow-up laser/surgery
 - d. Priapism—if it fails to resolve in 24 hours, exchange transfusion is given
 - e. Aplastic crisis—RBC transfusion to maintain haematocrit in the range of 18-20%. It usually resolves in 7-10 days.
6. *Antisickling agents*
 - a. Hydroxyurea increases HbF to 14-15%
 - b. Butyrate compounds increases HbF by increasing number of erythroblasts expressing gamma globin.
 - c. Decibitane can elevate HbF.
7. Folic acid 1 mg orally, daily.
8. Pneumovax in functional asplenia.
9. Bone marrow transplantation is under evaluation.
10. Monitor PCV, reticulocyte count, liver and spleen size.
11. Gene therapy is under investigation.

Splenomegaly is rare in sickle cell disease after the age of 5 years. If splenomegaly is present after 5 years, think of concomitant thalassaemia.

Thalassaemia

Haemoglobin consists of 2 different pairs of peptide chains (one alpha and the other beta) with the haem molecule attached to each peptide.

Adults have 95% HbA ($\alpha_2\beta_2$) + 5% HbA₂ ($\alpha_2\delta_2$).

Foetuses have HbF ($\alpha_2\gamma_2$) which continues to persist in beta-thalassaemia.

In thalassaemias, there is a reduced rate of production of one or more globin chains leading to precipitation of globin, and anaemia occurs as a result of ineffective erythropoiesis and haemolysis. This is common in Mediterranean areas and Far east.

Types

1. Alpha thalassaemia (reduced production of alpha chains)
2. Beta thalassaemia (reduced production of beta chains)
3. Haemoglobin H disease
4. Hb Barts
5. Beta thalassaemia intermedia.

Beta-Thalassaemia Major (Homozygotes) (Cooley's Anaemia)

Anaemia is very severe and the patients live only for a short time without blood transfusion. Bone marrow hyperplasia produces frontal bossing and prominent malar eminences which is seen in the skull X-ray as 'hair on end' appearance (Figs 6.9 and 6.10). Hb with



Fig. 6.9: Hair on end appearance



Fig. 6.10: Hair on end appearance

absent β -chains and only with insoluble α -chains are toxic to the erythroblasts resulting in their intramedullary destruction which causes ineffective bone marrow expansion by the release of erythropoietin in response to anaemia. There is growth retardation, splenomegaly, hepatomegaly and cardiomegaly.

These patients will have a characteristic chip-munk facies.

Beta-Thalassaemia Minor (Heterozygotes)

The course is very mild and often this anaemia is detected only when a therapy for a mild hypochromic anaemia fails. Symptoms are minimal.

Alpha-Thalassaemia

There are four alpha genes in chromosome 16 in normal individuals. Both sexes are affected. It may present as hydrops fetalis (all genes deleted) or haemoglobin H (3 genes deleted), or mild hypochromic microcytic anaemia (2 genes deleted) or asymptomatic (1 gene deleted).



Investigations

1. Thalassaemia major
 - a. Profound hypochromic anaemia, severe red cell dysplasia and plenty of target cell (Fig. 6.11)
 - b. Absence or severe reduction of HbA
 - c. Raised HbF
 - d. Family history showing both parents having thalassaemia minor.
2. Thalassaemia minor
 - a. Mild anaemia, microcytic hypochromic RBCs (total iron binding capacity, serum iron, ferritin levels are normal)
 - b. Some target cells, punctate basophilia
 - c. Raised HbA₂ 4-6% (normal HbA₂ 1.5 to 3%)
 - d. Family history with one parent having thalassaemia minor.

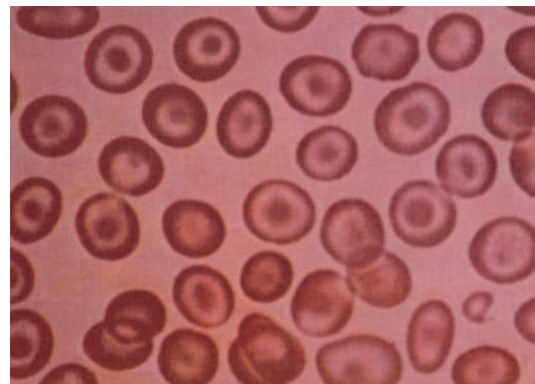

Fig. 6.11: Beta thalassaemia—plenty of target cells

To Differentiate between Iron Deficiency Anaemia and β -Thalassaemia Trait

Mentzer index (MCV/RBC in million) } > 13 - Iron deficiency anaemia
 } < 13 - β -thalassaemia trait

Normal MCV is 78-98 fl; MCV is often < 65 in β -thalassaemia trait. In iron deficiency anaemia, it is > 75 .

Prevention

Antenatal diagnosis is by PCR amplification of the globin gene.



Management

1. Regular blood transfusion to maintain hematocrit in the range of 30-35% or Hb in the range of 10 gm%.
2. Allogeneic bone marrow transplantation for erythropoietic failure.
3. Avoid iron therapy. Desferrioxamine is used as an iron chelating agent.
4. Splenectomy if hypersplenism occurs.
5. Give folate supplementation.
6. Manipulation of globin chain expression and gene therapy.
7. β -thalassaemia is difficult to manage.

Pancytopenia

Pancytopenia with hypo-cellular bone marrow

- Acquired aplastic anaemia
- Constitutional aplastic anaemia (Fanconi's)
- Rare aleukemic AML
- Some myelodysplastic syndrome
- Some acute lymphoid leukaemia
- Some lymphomas of bone marrow

Pancytopenia with cellular bone marrow

Primary bone marrow diseases

- Myelodysplasia syndromes
- Myelofibrosis
- Some aleukemic leukaemia
- Myelophthisis
- Bone marrow lymphoma
- Hairy cell leukaemia
- Paroxysmal nocturnal haemoglobinuria

Secondary to systemic disorders

- Hypersplenism
- B₁₂, Folate deficiency
- Severe infection
- SLE
- Alcohol

- Brucellosis
- Sarcoidosis
- Tuberculosis
- Leishmaniasis

Hypocellular marrow \pm Pancytopenia

- Q fever
- Legionnaires' disease
- Starvation
- Anorexia nervosa
- Mycobacterial infections.

Aplastic Anaemia

It is characterised by peripheral blood pancytopenia in association with bone marrow hypocellularity involving granulocytic, erythroid and megakaryocytic cell lines.

It is common in patients less than 20 years and greater than 60 years.

Aetiology of Aplastic Anaemia

1. Idiopathic (more than 50%)
2. Drug-induced (dose dependent, idiosyncratic)
 - a. Antimicrobials (chloramphenicol, sulfonamides, penicillins, quinacrine)
 - b. Anticonvulsants (phenytoin, trimethadione, ethosuximide, carbamazepine)
 - c. Antithyroid agents (carbimazole, tapazole, propylthiouracil)
 - d. Antidiabetic agents (tolbutamide, chlorpropamide, carbutamide)
 - e. Analgesics (phenylbutazone, aspirin, indomethacin)
 - f. Sedatives or tranquilizers (chlordiazepoxide, phenothiazines)
 - g. Miscellaneous (gold compounds, D-penicillamine, bismuth, ticlopidine, thiocyanates, acetazolamide)
3. Chemical or toxin (benzene, carbon tetrachloride, insecticides)
4. Radiation
5. Infection (hepatitis, parvovirus, tuberculosis, HIV)
6. Pregnancy (remits following delivery in some)
7. Thymoma (usually associated with pure red cell aplasia)
8. Paroxysmal nocturnal haemoglobinuria (PNH develops in 5-10% of patients with aplastic anaemia and 25% of patients with PNH develop aplastic anaemia)
9. Constitutional (Fanconi's anaemia, familial aplastic anaemia, dyskeratosis congenita)

10. Associated with myelodysplasia (patients with aplastic anaemia may develop a myelodysplastic syndrome later).



Clinical Features

Patient presents with weakness, fatigue, recurrent infections, bleeding in the form of ecchymoses, petechiae, epistaxis, or other more serious haemorrhage. Infection may aggravate thrombocytopenia.

On examination, patient is pale, may show evidence of bleeding, gingivitis, stomatitis, pharyngitis or proctitis; splenomegaly develops later in the course of the disease. *Hepatomegaly and lymphadenopathy are infrequent and suggest the association of other disease processes.*



Investigations

1. Anaemia (normocytic and normochromic)
2. Neutropenia (absolute neutrophil count $< 1500/\mu\text{l}$)
3. Lymphocytes show functional abnormalities due to cytotoxicity or by release of inhibitory cytokines.
4. Thrombocytopenia ($< 150,000/\mu\text{l}$)
5. Peripheral blood smear shows mild macrocytosis. Granulocytes and platelets are reduced.
6. Serum iron is elevated with saturation of iron-binding capacity.
7. *Bone marrow aspiration (Fig. 6.12):* This often yields a small amount of material. Smear reveals a

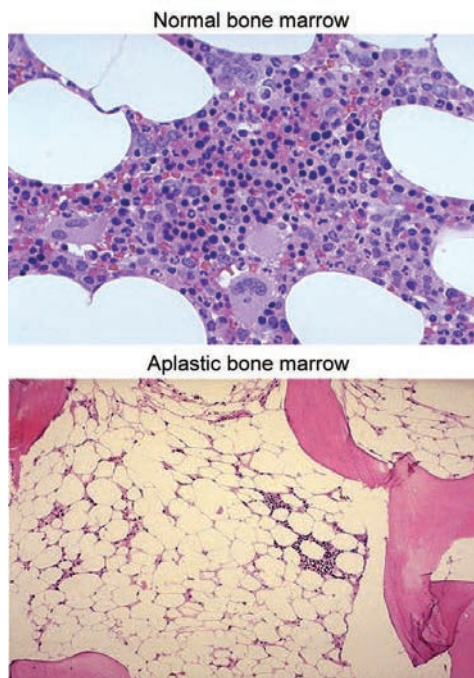

Fig. 6.12: Aplastic anaemia

predominance of lymphocytes, plasma cells, and occasional residual granulocytic, erythroid, or megakaryocytic elements. Bone marrow biopsy shows hypocellularity with predominance of fat cells. Iron stores are usually increased.

Criteria for Severe Aplastic Anaemia*

Blood

Neutrophils	$< 500/\mu\text{l}$
Platelets	$< 20,000/\mu\text{l}$
Reticulocytes	$< 1\%$ (corrected)

Bone marrow

Severe hypocellularity
Moderate hypocellularity with $< 30\%$ of residual cells being haematopoietic

*Note: Any two blood criteria and either one marrow criterion.

In very severe disease, the absolute neutrophils count is less than 200/microlitre.



Management

1. *General measures:* Avoiding exposure to crowd, strict aseptic precautions, prophylactic use of oral non-absorbable antibiotics, regular use of antiseptic soaps on the skin, use of electric razors, soft toothbrush, stool softeners are recommended. Intramuscular injections should be avoided.
2. Blood product replacement (RBC, platelet transfusions)
3. *Antibiotic therapy:* Fever or any sign of infection is an indication for empiric broad-spectrum antibiotic therapy.
4. Haematopoietic growth factors like GM-CSF, G-CSF, erythropoietin are given.
5. *Bone marrow transplantation:* It is the treatment of choice for patients less than 40 years of age. In HLA matched sibling donors, the results are better in untransfused patients (80% long-term survival) than in transfused patients (60-75% survival).
6. *Immunosuppression*
 - a. *Antithymocyte globulin (ATG):* It acts through elimination of activated suppressor T-cells. The recommended dosage is 10-20 mg/kg body weight daily for 8-14 days as an infusion along with prednisone 40 mg/sqm/day for 2 weeks to prevent serum sickness.
 - b. *Cyclosporine A:* In a dose of 3-7 mg/kg/day in 2 doses with weekly dose adjustments and continued for 3 months.

- c. ATG plus cyclosporine A
 - d. High dose of cyclophosphamide or mycophenolate mofetil can be tried.
7. Other measures
- a. *Corticosteroids*: It should be given for patients refractory to other modalities of treatment and also for patients with immunologic mechanism responsible for marrow suppression
 - b. Splenectomy for pancytopenia.

Blood Transfusion

The total blood or its individual components can be transfused. It is highly beneficial and at the same time it is highly risky with potentially life threatening side effects.

Indications

- Blood loss in accidents.
 - Blood loss in surgery.
 - Severe anaemia (iron deficiency, thalassaemia, aplastic anaemia, anaemia of chronic disease-connective tissue disorders, infections, malignancy)
 - Bleeding disorders
 - Extensive burns
- One unit of RBCs increases the Hb by 1g/dL in the average adult.

Manipulation of Blood Products

- Packed cell transfusion for severe anaemia to avoid volume overload
- Plasma transfusion
- Platelet transfusion
- Leukoreduced blood products are recommended:
 - i. To avoid non-haemolytic febrile reactions due to cytokines released from WBCs
 - ii. To prevent CMV infection
 - iii. To prevent the formation of platelet allo-antibodies
- Irradiation of blood products eliminates immunologically competent lymphocytes and is used for immunocompromised bone marrow or organ transplant recipients.
- Washed RBCs for patients in whom plasma protein may cause serious reaction (IgA deficient recipient).

Precautions

1. Use 18 gauge needle for adequate free flow.
2. Observe the patient for 5-10 minutes after starting the transfusion and then at regular intervals.

3. Transfusion should be completed within 4 hours of delivery to the bedside.
4. Duration of infusion – 2-3 hours



Complications

Transfusion—transmitted infections:

- HIV-1 and 2
- Human T-lymphotropic virus type 1
- Hepatitis B and C
- CMV transmission from RBC and platelet transfusion
- Bacterial transmission

Non-infectious complications:

- Acute haemolytic reactions due to ABO- incompatible blood as evidenced by fever, chills, back pain, chest pain, nausea, vomiting, hypotension and acute renal failure.

Management: Transfusion should be stopped immediately. Replace the IV line. Do Coombs' test along with freshly voided urine examination for free Hb.

Maintain urine output 100 mL/hour either with the use of IV fluids, diuretics or mannitol, if needed. The excretion of free Hb can be accelerated by adding sodium bicarbonate to IV fluid for alkalinisation of urine.

- Delayed haemolytic transfusion reactions occur 3-10 days after transfusion with a fall in Hb and Hct level. The treatment is similar to acute haemolytic reactions.
- Non-haemolytic febrile reactions are due to cytokines released from WBCs. Use acetaminophen and pre-storage leukoreduced blood products.
- Allergic reactions—It is an IgE mediated response to serum proteins in the form of urticaria, bronchospasm or hypotension. The treatment is symptomatic.
- Anaphylactic reactions—It is commonly due to IgA deficient patient receiving IgA containing blood products. Glucocorticoids are useful.
- Volume overload—Slow the rate of transfusion and use diuretics.
- Transfusion related acute lung injury (TRALI)—similar to ARDS within 4 hours of transfusion. Stop the transfusion and provide ventilatory assistance.
- Transfusion associated graft versus host disease—It is seen in immunocompromised patients due to infusion of immunocompetent T-lymphocytes. The symptoms include rash, elevated liver enzymes, and pancytopenia. The mortality is > 80%. Irradiation of blood products prevents this type of reaction.

- Post-transfusion purpura—Bleeding starts 7-10 days after transfusion and is due to severe thrombocytopenia.

Adverse effects due to massive transfusion:

- Hypothermia due to transfusion of chilled blood. Use blood warming device.
- Citrate intoxication especially in patients with hepatic dysfunction.
- Hypocalcaemia—Treat with IV calcium gluconate.
- Hypokalaemia—It is due to metabolically active RBCs consuming potassium from plasma.
- Hyperkalaemia is rare and is due to renal failure or muscle injury.

Disorders of the White Cells

The Neutrophils

Absolute count: $2.5-7.5 \times 10^9/l$ (2500-7500/ μL)

Neutrophils constitute about 40-75% of WBCs.



Causes of Neutrophilia (>10,000/ μL)

1. Bacterial infection
2. Trauma
3. Burns
4. Surgery
5. Haemorrhage
6. Inflammation
7. Myocardial infarction
8. Polyarteritis nodosa
9. Myeloproliferative disorders.
10. Drugs (steroids, lithium, epinephrine)
11. Malignant disease (stomach, breast, lung)
12. Rheumatoid arthritis
13. Cytokines (G-CSF, GM-CSF)
14. Metabolic-DKA, uraemia
15. Splenectomy.



Causes of Neutropenia (< 2,500/ μL)

1. Viral infection (hepatitis, infectious mononucleosis, HIV, influenza)
2. Bacterial infection (brucellosis, typhoid fever, miliary tuberculosis, fulminant sepsis) esp. when count is < 1,000/ μL .
3. Protozoal diseases—kala-azar, malaria
4. Drugs (antithyroid drugs, antimalarials, anticonvulsants, ACE inhibitors, antiarrhythmics)
5. Nutritional deficiency (vitamin B₁₂, folate)

6. Collagen vascular disorders (Felty's syndrome, SLE, lymphoma)
7. Cyclical neutropenia.

The Lymphocytes

Absolute count: $1.3-3.5 \times 10^9/l$ (1300-3500/ μL)

It constitutes about 20 to 45% of WBCs.



Causes of Lymphocytosis (> 5,000/ μL)

1. Infections
 - a. Viral infection (EB virus, CMV, Rubella)
 - b. Toxoplasmosis
 - c. Whooping cough
 - d. Brucellosis
 - e. Tuberculosis
 - f. Syphilis
2. Malignancy
 - a. Acute and chronic lymphatic leukaemia.
 - b. Non-Hodgkin's lymphoma
3. Others
 - a. Serum sickness
 - b. Thyrotoxicosis
 - c. Adrenal insufficiency.



Causes of Lymphocytopenia (< 1,000/ μL)

- a. Steroid therapy
- b. Uraemia
- c. Legionnaire's disease
- d. AIDS
- e. Infiltration of bone marrow
- f. After chemotherapy or radiotherapy
- g. Whipple's disease
- h. Severe right sided heart failure
- i. Immunoglobulin disorders (ataxia telangiectasia, thymic dysplasia)
- j. Intestinal lymphangiectasis (due to increased lymph loss)
- k. Acute stressful illness (MI, sepsis, pneumonia).

The Eosinophils

Absolute count: $0.04-0.44 \times 10^9/l$ (40-440/ μL)

It constitutes about 1 to 6% of WBCs.



Causes of Eosinophilia (> 500/ μL)

1. Asthma and allergic disorders
2. Parasitic infections (strongyloidiasis, hookworm diseases, scabies, ascariasis, filariasis*)

3. Hypereosinophilic syndrome (Loeffler's syndrome); associated with an eosinophil count of more than $1.5 \times 10^9/l$ for more than 6 weeks; treated with steroids or cytotoxic drugs)
4. Collagen vascular disorders (polyarteritis nodosa, SLE, rheumatoid arthritis, scleroderma)
5. Skin disorders (pemphigus, psoriasis, eczema, eosinophilic cellulitis, fascitis)
6. Tumours (eosinophilic leukaemia, lymphomas, Hodgkin's disease, myeloproliferative disorders)
7. Sarcoidosis
8. Immunodeficiencies (Wiskott-Aldrich syndrome, hyper-IgE syndrome, IgA deficiency)
9. Endocrine disease (Addison's disease, hypopituitarism)
10. Interstitial nephritis
11. Postsplenectomy
12. Postviral illness.

*Note: *Tropical eosinophilia:* It is caused by lymphatic filarial species. Major symptoms and signs are nocturnal cough and wheeze, fever, weight loss, lymphadenopathy \pm hepatosplenomegaly. Investigations reveal - increased ESR, absolute eosinophil count $> 3000/\mu L$, and raised serum IgE levels. It is treated with diethylcarbamazine 100 mg tds for 2 weeks.

Eosinophilia-myalgia syndrome: Consists of myalgia, arthralgia, fever with rashes, swelling of the arms, and an intense eosinophilia due to contaminants in L-tryptophan containing dietary supplements.



Causes of Eosinopenia ($< 40/\mu L$)

1. Acute stressful illness
2. Steroid therapy.

The Monocytes

Absolute count: $0.2-0.8 \times 10^9/l$ (200-800 cells/ μL)
It constitutes about 2 to 10% of WBCs.



Causes of Monocytosis (More than $800/\mu L$)

1. Infection (TB, brucellosis, syphilis, bacterial endocarditis)
2. GIT disorders (inflammatory bowel disease)
3. Collagen vascular diseases (SLE, polyarteritis nodosa, rheumatoid arthritis)
4. Haematological disorders (acute monocytic and myelomonocytic leukaemia, Hodgkin's disease)
5. Sarcoidosis.

Difference between Leukaemia and Leukaemoid Reaction

Leukaemia	Leukaemoid reaction
1. No specific aetiology	Inflammatory disease recognised (pneumonia, vasculitis)
2. Neutrophils: Left shift with myeloid cells earlier than bands; WBC $> 100,000/\mu L$	Mature neutrophils $> 90\%$ and WBC usually $< 50,000/\mu L$
3. Leukocyte alkaline phosphatase (LAP) low in CML	Leukocyte alkaline phosphatase (LAP) high
4. Eosinophilia, basophilia, or monocytosis frequently seen	Not seen
5. Platelets—qualitatively abnormal, large; count $> 1,000,000/\mu L$; abnormal aggregation; thrombocytopenia may occur	Platelets—small; not more than $600,000-700,000/\mu L$ with normal aggregation
6. Splenomegaly (25-75%)	No splenomegaly
7. Bone marrow—megakaryocytic and platelet clumping; possibly fibrosis	Bone marrow—hyperplastic with normal karyotype
8. Karyotype may be abnormal, esp. in CML with the Philadelphia chromosome; bcr-abl by Southern blot or PCR; clonality by X-linked inactivation techniques	None of these changes are seen



Causes of Monocytopenia ($< 100/\mu L$)

1. Acute stressful illness
2. Steroid therapy
3. Aplastic anaemia
4. Leukaemia
5. Chemotherapy or immunosuppressives.

The Basophils

Absolute count: $0-0.1 \times 10^9/l$ (0-100 cells/ μL)
It constitutes about 0 to 1% of WBCs.



Causes of Basophilia ($> 100/\mu L$)

1. Infections (viral, TB)
2. Myeloproliferative disorders (CML, polycythaemia rubra vera)
3. Malignancy
4. Systemic mastocytosis (urticaria pigmentosa)

5. Myxoedema
6. Post-splenectomy
7. Ulcerative colitis
8. Allergic disorders.

Myeloproliferative Disorders

These are a group of disorders characterised by proliferation of each or all of the precursors for myeloid elements—RBC, WBC and platelets.

Predisposing Conditions

- Old age – Median age 60 years
- Male preponderance
- Congenital disorders – Down syndrome, monozygous twinning
- Fanconi's anaemia
- Systemic mastocytosis
- PNH
- Idiopathic sideroblastic anaemia
- Pernicious anaemia
- Cigarette smoke
- Ionising radiation
- Viruses – HTLV-1, EBV
- Chemicals
Benzene, Toluene, Cancer chemotherapeutic agents, pesticides, hair-dyes, industrial solvents
- Occupation – Petroleum workers, Rubber factory, Miners

Classification

RBC	Polycythaemia
WBC	Chronic myeloid leukaemia
Platelets	Essential thrombocythaemia
Fibroblasts	Primary myelofibrosis (agnogenic myeloid metaplasia)

They may undergo transformation into acute leukaemia. Blood count reflects two processes:

1. Proliferating cell line (may involve other myeloid elements also)
2. Marrow infiltration (may cause a decrease in normal cells).

The WHO has included three more entities:

1. Chronic neutrophilic leukaemia
2. Chronic eosinophilic leukaemia
3. Chronic MPD – Unclassified

The WHO has also named a specific group presenting neither as MPD or MDS:

- i. Chronic myelomonocytic leukaemia
- ii. Atypical CML

- iii. Juvenile myelomonocytic leukaemia
- iv. MPD/MDS – Unclassified.

Polycythaemia Vera

It is a myeloproliferative disorder with an absolute increase in red blood cell mass. It is associated with lower levels of erythropoietin and an absolute increase in the number of myeloid stem cells which are extremely sensitive to small amounts of erythropoietin. Median age of presentation is 60 years with male preponderance.



Clinical Features

Clinical symptoms are due to increased blood volume, viscosity, vascular stasis, thrombotic tendency and haemorrhagic diathesis. Patients are plethoric and cyanotic (owing to stagnation and deoxygenation of blood in periphery).

Angina, CNS disturbance, gout (hyperuricaemia), headache, dizziness, hypertension, GI symptoms, peptic ulcer disease, haematemesis, melena, abdominal pain, (splenic or renal infarction) pruritus exaggerated by a warm bath due to release of histamine from basophils may also occur. Splenomegaly is present in most cases (75%).

Erythromelalgia is a syndrome of unknown aetiology involving the lower limbs and manifested usually by erythema, warmth and pain of the affected appendage and digital infarction. It is usually responsive to salicylates.



Investigations

1. PCV is elevated > 60%
2. Elevated RBC count 7-10 million/ μ L
3. Hb level > 18 gm/dL in males and > 16 gm/dL in females
4. Elevated white cell and platelet counts
5. Hypercellular marrow with erythropoiesis or granulopoiesis and megakaryocytes
6. Absent iron stores
7. Elevated serum B_{12} levels > 900 pg/ml
8. Elevated neutrophil alkaline phosphatase score
9. Hyperuricaemia, pseudohyperkalaemia (due to release of potassium from platelets during *in vitro* coagulation).

Criteria for Diagnosis of Polycythaemia Vera

Category A

1. Total red cell mass:
Male \geq 36 ml/kg
Female \geq 32 ml/kg

2. Arterial oxygen saturation $\geq 92\%$
3. Splenomegaly.

Red cell mass can be normal in PV if there is massive splenomegaly or bleeding.

Category B

1. Thrombocytosis (platelets $> 400 \times 10^3/\mu\text{L}$)
2. Leukocytosis (white blood cells $> 12 \times 10^3/\mu\text{L}$)
3. Increased leukocyte alkaline phosphatase (LAP) score
4. Serum $\text{B}_{12} > 900 \text{ pg/ml}$ or B_{12} binding capacity $> 2200 \text{ pg/ml}$.

PV is diagnosed when A1 + A2 + A3 or A1 + A2 and any 2 from category B are present.

Over a period of time, these patients may progress to myelofibrosis or CML.



Causes of Secondary Erythrocytosis (Secondary Polycythaemia)

1. Increased production of erythropoietin secondary to hypoxia
 - a. High altitude
 - b. Lung disorder
 - c. Smoking
 - d. Cyanotic congenital heart disease
 - e. High affinity haemoglobins (Hb-M)
 - f. Supine hypoventilation
 - g. Carbon monoxide toxicity
 - h. Sleep apnoea syndrome
2. Inappropriate erythropoietin production: Tumours of kidney, liver, lung, uterus, and cerebellum.
 - a. Renal cysts
 - b. Hydronephrosis
 - c. Hypernephroma
 - d. Renal artery stenosis
 - e. Renal transplantation
 - f. Hepatoma
 - g. Pheochromocytoma
 - h. Uterine fibromyoma
 - i. Cerebellar haemangioblastoma
 - j. Meningiomas
 - k. Adrenal adenomas
 - l. Bartter's syndrome
 - m. Androgen therapy
 - n. Recombinant erythropoietin therapy.

Spurious or Low Plasma Volume Polycythaemia (Geisbock Syndrome)

This is due to reduced plasma volume. It often occurs with stress, hypertension, occlusive vascular disease.

Erythropoietin

Erythropoietin increase suggests hypoxia or autonomous production of Epo as a cause for erythrocytosis. In PV, the Epo is normal or decreased but never increased. A normal Epo does not exclude hypoxia as a cause.



Management

1. Venesection (500 ml) of blood is removed in one sitting and it may be repeated within a day or two if necessary until hematocrit comes down to 50%. Iron removed in phlebotomy = Hematocrit/cc \times volume of blood removed.
2. Chemotherapy with hydroxyurea is equally effective. It is less leukaemogenic compared to radioactive phosphorus.
3. Symptomatic thrombocytosis or splenomegaly can be treated with interferon alfa.
4. Anagrelide-a quinazolin derivative and platelet anti-aggregant that also lowers platelet count and can also control thrombocytosis.
5. Allopurinol may be given during chemotherapy to avoid hyperuricaemia.
6. Intractable pruritus can be controlled with hydroxyurea or IFN- α or PUVA therapy.
7. Allogenic bone marrow transplantation in young patients
Drug chemotherapy should be as short as possible to avoid leukaemic reaction.

Prognosis

Median lifespan in treated patients is more than 10 years. Acute leukaemia develops in those patients treated with radioactive phosphorus, chlorambucil.

Overtime polycythaemia vera may progress to myelofibrosis or CML.

Essential Thrombocythaemia (Primary Thrombocytosis)

This is characterised by a very high platelet count of more than $600 \times 10^9/\text{l}$. Platelet is abnormal morphologically and functionally and the disease may present with thrombosis or bleeding.



Causes of Thrombocytosis

- Iron deficiency anaemia
- Hyposplenism
- Post-splenectomy
- Malignancy

- Collagen vascular disease
- Inflammatory bowel disease
- Infections
- Haemolysis/haemorrhage
- Polycythaemia vera
- Idiopathic myelofibrosis
- Essential thrombocytosis
- Idiopathic sideroblastic anaemia
- Myelodysplasia (5q – syndrome)
- CML
- Post surgery
- Rebound (cessation of ethanol intake, correction of vitamin B₁₂ and folate deficiency).



Clinical Features

Thirty per cent of patients are asymptomatic; others present with GI bleed, arterial clotting, paraesthesias, erythromelalgia (burning feet), vascular headaches. Splenomegaly is present in 75% and hepatomegaly is rare (20%). Some patients show Howel-Jolly bodies as an evidence of autosplenectomy.

Diagnostic Criteria

- a. Platelet count greater than 600,000/ μ L on two occasions.
- b. Palpable spleen (60-75% of cases).
- c. Haemoglobin and haematocrit in normal range (normal red cell mass: men < 36 ml/kg; female < 32 ml/kg).
- d. Adequate iron stores in the bone marrow.
- e. Absence of Philadelphia chromosome (Ph¹ negative). In addition, the abl/bcr gene rearrangement is not found.
- f. Minimal to absent marrow fibrosis (reticulin).
- g. No known cause for reactive (or secondary) thrombocytosis.



Management

Treatment depends on urgency.

1. In an asymptomatic young patient < 40 years, consider aspirin 60 mg/day and observe.
2. Busulphan or hydroxyurea 25 mg/kg/day orally if the platelet count is > 800 \times 10⁹/l.
3. Bleeding can be controlled with Epsilon amino-caproic acid.
4. Interferon alpha is given for extreme thrombocytosis in a dose of 2-4 mU/m² SC, daily or 3 times a week.
5. When the blood film shows megakaryocytic leukaemia, it is treated like AML.

6. Anagrelide, 0.5-1.0 mg qid PO (causes isolated platelet reduction with minimal toxicity) is under trial.

Primary Myelosclerosis (Myelofibrosis)

There is intense marrow fibrosis with resultant haemopoiesis in the spleen and liver (myeloid metaplasia) causing massive splenomegaly.



Clinical Features

Patients have lassitude, weight loss, night sweats, heat intolerance, aches in muscles, bones and joints. There is marked splenomegaly. The causes of death are MI, GI bleed, leukaemic transformation, infection, major thrombosis.

Exuberant extramedullary haematopoiesis can cause ascites, pulmonary hypertension, intestinal or ureteric obstruction, increased ICT, spinal cord compression and skin nodules. Gout due to hyperuricaemia is also seen.



Investigations

1. Blood film shows macrocytic anaemia, leucoerythroblastic picture, tear drop poikilocytes
2. Neutrophil alkaline phosphatase score is high
3. Raised urate levels
4. Bone marrow biopsy shows an excess of megakaryocytes and increased reticulin and fibrous tissue replacement. Usually there is dry tap.

Diagnostic Criteria

1. Splenomegaly (may be huge)
2. Anaemia (haemolytic and decreased production components)
3. Leukocytosis or thrombocytosis may be seen in 60% of patients
4. Leukoerythroblastic peripheral blood picture
5. Tailed (dacrocytes) cells on blood smear
6. Bone marrow fibrosis (reticulin), which may be extensive (Fig. 6.13)
7. Osteosclerosis seen on skeletal X-rays.



Management

1. Blood transfusion
2. Folic acid (50 mg/day)
3. Androgen therapy (oxymetholone 50 mg/day)

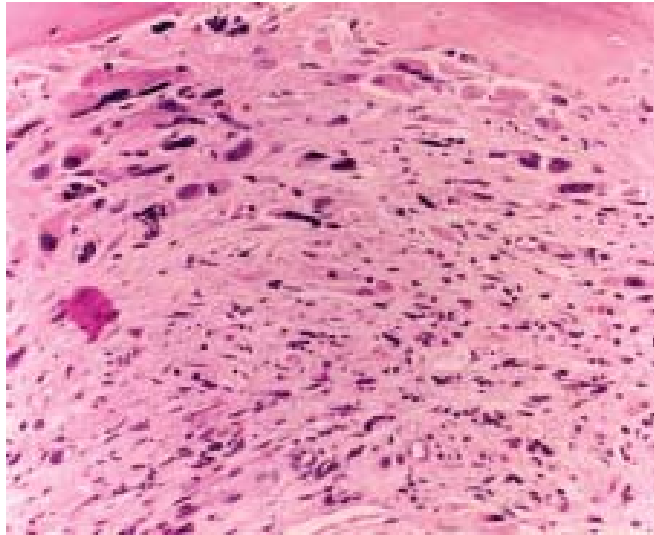

Fig. 6.13: Bone marrow—myelofibrosis

4. Corticosteroids (prednisolone 40 mg/day)
5. Cytotoxic drugs (hydroxyurea upto 2 gm/day)
6. Splenectomy (in mechanical embarrassment due to massive splenomegaly, severe haemolysis, hypermetabolism, painful splenomegaly, hypersplenism).
Splenectomy is contraindicated in active DIC with fibrinolysis, elevated fibrin split products, increased D-dimer, elevated fibrin monomer, hypofibrinogenaemia.
7. Radiation to the spleen in small daily doses of 25 to 50 cGy for painful splenomegaly. Focal radiation for controlling extramedullary haematopoiesis.
8. Bone marrow transplantation.

Prognosis

The disease is progressive with steady deterioration.

Myelophthisic Anaemia

It is a term used to define conditions producing marrow fibrosis and the resulting clinical features are similar to primary idiopathic myelofibrosis.

Bone marrow fibrosis is also seen in the following conditions:

1. Other MPDs
2. Hairy cell leukaemia
3. Carcinoma (breast, prostate, ovary) metastatic to bone marrow
4. Radiation therapy for lymphoma and other neoplasms
5. Benzene exposure
6. Miliary tuberculosis
7. Granulomatous diseases

8. Parathyroid disease
9. Paget's disease.

Conditions associated with increased leukocyte alkaline phosphatase score

1. Polycythaemia vera
2. Myelosclerosis
3. Essential thrombocythaemia
4. Hairy cell leukaemia.

Conditions associated with decreased leukocyte alkaline phosphatase score

1. CML
2. Paroxysmal nocturnal haemoglobinuria
3. Aplastic anaemia.

Haematological Malignancies

They can be arising from cells of myeloid or lymphoid series. The myeloid group is further sub-classified into acute myeloid leukaemia and chronic myeloid leukaemia.

The WHO has classified lymphoid malignancies into those arising from T-cells or B-cells and Hodgkin's disease.

Lymphoid Malignancies

B-cell

Precursor B lymphoblastic leukaemia/Lymphoma (Precursor B-cell acute lymphoblastic leukaemia)

Mature B-cell Neoplasms

- B-cell chronic lymphocytic leukaemia/small lymphocytic lymphoma
- Hairy cell leukaemia
- B-cell lymphoma of MALT type (Extranodal – mucosa associated lymphoid tissue)
- Mantle cell lymphoma
- Follicular lymphoma
- Diffuse large B-cell lymphoma
- Burkitt's lymphoma/Burkitt cell leukaemia
- Plasma cell myeloma/Plasmacytoma

T-cell

Precursor T-lymphoblastic lymphoma/Leukaemia (Precursor T-cell acute lymphoblastic leukaemia)

Mature T-cell Neoplasms

- T-cell prolymphocytic leukaemia
- T-cell granular lymphocytic leukaemia
- Adult T-cell lymphoma/leukaemia (HTLV-1+)
- Aggressive NK cell leukaemia
- Extranodal NK/T-cell lymphoma – nasal type
- Mycosis fungoides/Sezary syndrome
- Peripheral T-cell lymphoma
- Anaplastic large cell lymphoma.

Hodgkin's Disease



Leukaemias

Leukaemias are malignant neoplasms of the haematopoietic stem cells, arising in the bone marrow, that flood the circulating blood or other organs. They are classified on the basis of the cell type involved and the state of maturity of leukaemic cells.

Acute Myeloid Leukaemia

The incidence of AML steadily increases with age. Ninety per cent of cases of AML occurs in adults. The incidence is greater after the age of 65.

Aetiology

1. Hereditary
 - Down's syndrome, Patau's syndrome, Klinefelter's syndrome
 - Inherited diseases like Ataxia telangiectasia, Bloom's syndrome, Fanconi's anaemia
2. Radiation
3. Chemical and other occupational exposures
No direct evidence suggests a viral aetiology.

Classification

The categorisation of acute leukaemias into biologically distinct groups is based on morphology, cytochemistry, and immunophenotyping as well as cytogenetic and molecular techniques.

According to WHO, the diagnosis of AML is established by the presence of > 20% blasts in blood and/or bone marrow. The WHO classification modified the FAB system by reducing the number of blasts required for the diagnosis and incorporating molecular (including cytogenetics), morphologic (multilineage dysplasia) and clinical features (such as a prior haematologic disorder) in defining disease entities.

World Health Organisation Classification

- I. AML with recurrent genetic abnormalities
- II. AML with multilineage dysplasia (Following myelodysplastic or myeloproliferative disorder)
- III. AML and myelodysplastic syndromes – therapy related
- IV. AML not otherwise categorised
 1. AML minimally differentiated

FAB classification AML (Fig. 6.15)

Class/incidence	Morphology	Comments
M 0–Minimally differentiated AML (2-3%)	Blasts lack cytological and cytochemical markers of myeloblast. Express myeloid antigens (CD ₁₃ and CD ₃₃), Resembles myeloblasts ultrastructurally	
M 1–AML without differentiation (20%)	Very immature cell but >3% peroxidase positive with few granules or Auer rods, little maturation beyond myeloblast stage	Associated with Inv (3)
M 2–AML with maturation (30–40%)	Full range of myeloid maturation Auer rods positive in most cases	Younger age –myeloid sarcomas, Presence of t(8;21) denotes favourable prognosis
M 3–Acute pro-myelocytic leukaemia (5-10%)	Majority of cells are hypergranular promyelocytes, Many Auer rods/cell – Faggot cells	Patients are younger and develop DIC, t (15;17) is characteristic
M 4–Acute myelomonocytic leukaemia (15-20%)	Myeloid elements resemble M 2 AML Monoblasts stain positive for non-specific esterases	
M 4 Eo–myeloblastic with abnormal eosinophils	Presence of chromosome 16 abnormalities defines this subset with marrow eosinophilia	Excellent prognosis
M 5–Acute monocytic leukaemia (10%)	M 5a –Monoblasts with promonocytes predominate in marrow and blood M 5b – Mature monocytes predominate in peripheral blood	Old patients, high incidence of organomegaly, Lymphadenopathy and tissue infiltration
M 6–Acute erythroleukaemia (Diguglimo's syndrome) (5%)	Dysplastic erythroid precursors predominate (> 50%) Myeloblasts as in M 1	Advanced age, 1% denova AML 20% therapy related AML
M 7–Acute megakaryocytic leukaemia (1%)	Megakaryocytic blasts predominate GP II b/IIIa (CD 41/61) positive Often with prominent marrow fibrosis	Least common type

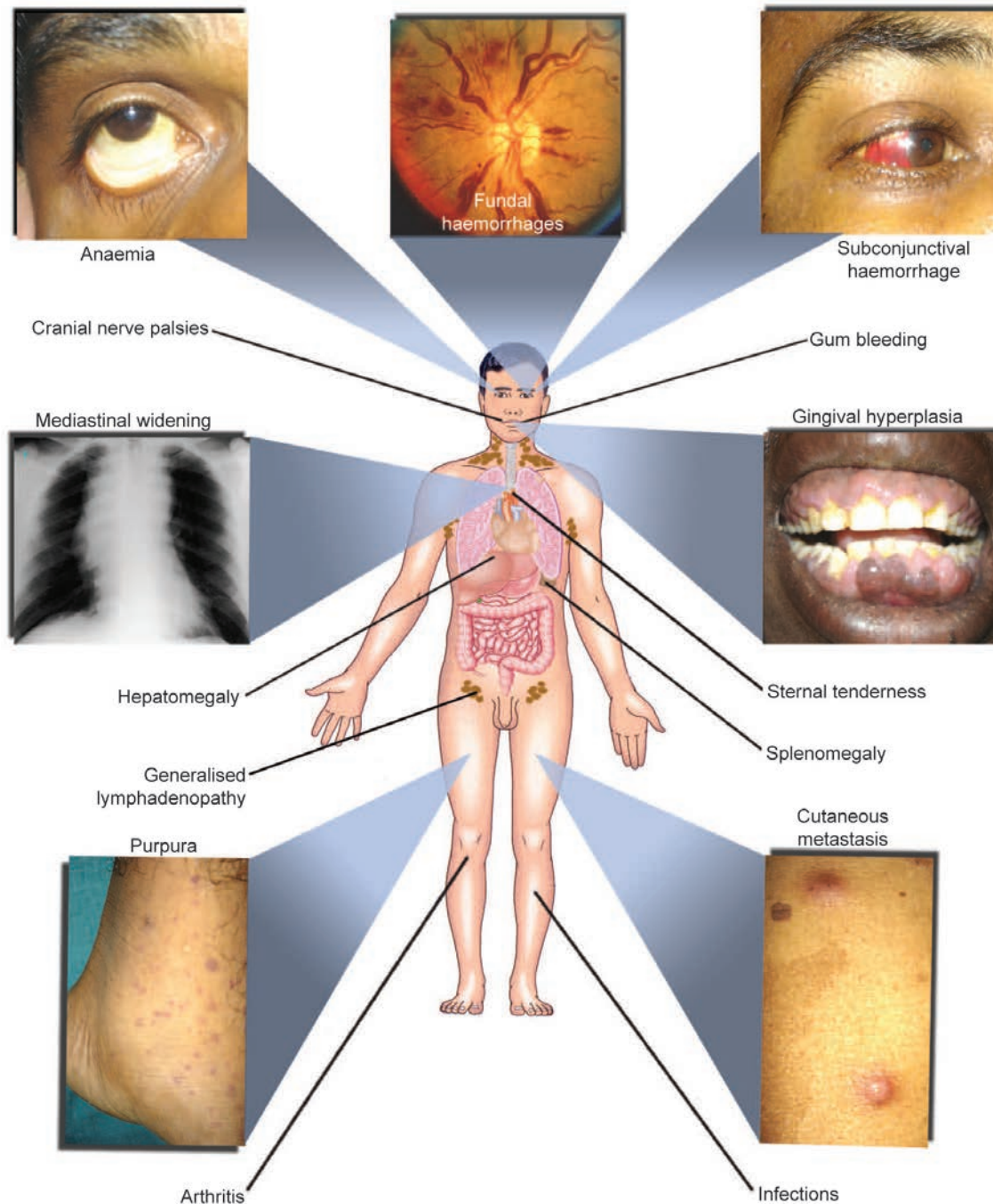

Fig. 6.14: Clinical features in acute leukaemia

2. AML without maturation
3. AML with maturation
4. Acute myelomonocytic leukaemia
5. Acute monoblastic and monocytic leukaemia
6. Acute erythroid leukaemia
7. Acute megakaryoblastic leukaemia
8. Acute basophilic leukaemia

9. Acute panmyelosis with myelofibrosis
10. Myeloid sarcoma



Clinical Features (Fig. 6.14)

The onset is abrupt and stormy. The symptoms include fatigue (50%), anorexia, weight loss, fever (10%), easy

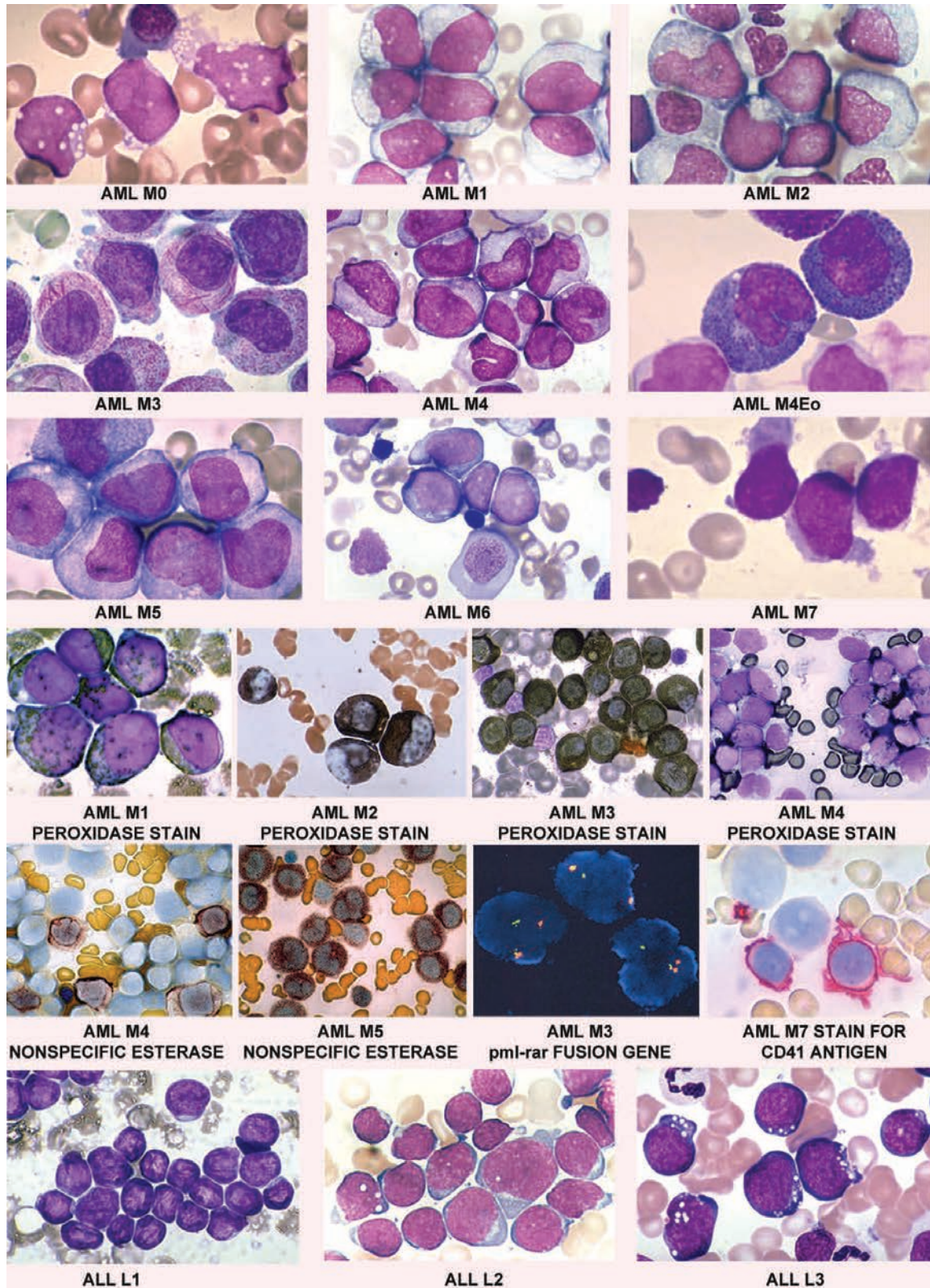

Fig. 6.15: Acute leukaemia (Myeloid and Lymphoid)

bruising/bleeding (5%), headache, cough, diaphoresis, and bone pain. Rarely, patients may present with a mass lesion (granulocytic sarcomas or chloromas). The signs include lymphadenopathy, hepatomegaly, splenomegaly, sternal or bone tenderness, evidence of infection and haemorrhage. Infiltration of gingival, skin, meninges and soft tissues is characteristic of M4 and M5 subtypes. DIC is more common with M3.



Investigations

WBC count

Average—15,000/ μ L

25–40%—< 50,000/ μ L

20%—> 100,000/ μ L

Less than 5%—No leukaemic cells in periphery (Aleukemic leukaemia)

RBC—Normochromic normocytic anaemia

Platelets—decreased

Bone marrow examination: > 20% blasts establish the diagnosis. Bone marrow examination is essential to exclude acute leukaemia in patients with pancytopenia.

Differentiation between myeloblasts and lymphoblasts is made morphologically and by cytochemistry.

Myeloblast	Lymphoblast
Delicate nuclear chromatin	Condensed chromatin
2 or 4 nucleoli	Absence of conspicuous nucleoli
More cytoplasm (granular)	Scanty agranular cytoplasm
Peroxidase positive	Peroxidase negative
PAS negative	PAS positive
	High levels of Tdt

Further subtyping of AML—Myeloblasts of M4 and M5 subtypes are strongly positive for non-specific esterase and lysozyme. The diagnosis of M6 is made if erythroid precursors are > 50% of all nucleated cells and blasts > 20% of non-erythroid cells (WHO).

Biochemical investigations: Elevated serum uric acid
Elevated LDH levels.

Imaging for mass lesions: Suitable imaging is needed for suspected mass lesions causing symptoms.

Prognostic factors in AML

Clinical	Favourable	Unfavourable
Age	< 40 years	> 60 years
Leukaemia	De novo	Secondary
WBC count	< 10,000	100,000
DIC	Absent	Present

LDH	Normal	Increased
Serum albumin	Normal	Decreased
FAB type	M3, M4, Eo	M0, M5a, M5b, M6, M7
Cytogenetics	T (15; 17), inv 16	5q ⁻ , 7 ⁻ , + 8
Auer rod	Positive	Absent
Bone marrow		
Fibrosis	Absent	Present
Cytoreduction	Rapid	Slow
Complete remission	Single	Multiple
Pronormoblasts	Rare	Many
Eosinophils	Present	Absent

Performance status is equally important in assessing the prognosis.

Complete Remission

The following criteria must be achieved on completion of induction phase.

Peripheral Smear

Neutrophil count > 1500/ μ L

Platelet count > 100,000/ μ L

No circulating blasts.

Bone marrow

Cellularity > 20% with trilineage maturation

< 5% blasts and no Auer rods

No extramedullary leukaemia

Note: Haemoglobin or Hct are not considered for complete remission.



Management

The treatment of AML is divided into two phases.

1. Induction
2. Post remission management

Induction

Standard drugs – Cytarabine + An Anthracycline (7 × 3 regimen) ± Etoposide.

Post Remission Management

1. High dose Cytarabine – 3 g/m²/day on 1, 3, 5 days every 12 hourly.
2. Bone marrow transplantation—Allogenic/Autologous
3. Novel therapies in old age

The addition of etoposide does not increase the CR rate but increases CR duration.

Treatment of Promyelocytic Leukaemia

Tretinoin (all trans retinoic acid) induces the differentiation of leukaemia cells bearing

Drug	Mechanism	Dosage	Duration
Cytarabine	'S' phase specific Interferes with DNA synthesis	100–200 mg/m ² /day IV	1–7 days
Anthracyclines Daunorubicin	Inhibition of Topoisomerase II Leading to DNA breaks	40–60 mg/m ² /day IV	1, 2, and 3 days
(OR) Idarubicin		12–13 mg/m ² /day IV	1, 2, and 3 days

t (15; 17) translocation, and it is not effective in other forms of AML.

- Tretinoin—45 mg/m²/day PO with an anthracycline until remission is achieved.
- Maintain with tretinoin or anthracycline.

Complications of Therapy

Myelosuppression, pulmonary toxicity, Irreversible cerebellar damage with high dose cytarabine, DIC, retinoic acid syndrome.

Supportive Care

- Blood transfusion to maintain Hb more than 8 g%.
- Platelet transfusion
- Use of growth factors – CSF, G-CSF in high risk patients to hasten neutrophil recovery
- Broad-spectrum antibiotics – Antibacterial/Antifungal

Relapse

Once relapse occurs, patients are rarely cured with standard dose chemotherapy and should be planned for BMT.

Chronic Myeloid Leukaemia (CML)

CML affects adults between 25 and 60 years of age, and accounts for 15 to 20% of all cases of leukaemia.

Radiation is an aetiological agent. Cigarette smoking accelerates progression to blastic crisis.

Peak incidence—fourth and fifth decades of life. It is a myeloproliferative disorder with a slight male preponderance.

The course has three phases:

1. Chronic phase—responds to treatment (3 to 5 years)
2. Accelerated phase (occasionally seen)
3. Blast crisis phase—disease transforms into acute leukaemia, either myeloid or lymphatic.

About 85% of patients develop acute leukaemia either abruptly or after 3–6 months of an accelerated phase most commonly myeloid and lymphoid in 30%.

Cytogenetic and Molecular Aspects

Ninety per cent of patients with CML have Philadelphia chromosomes (Ph). Ph chromosomes occur as a result of reciprocal translocation of material between chromosomes 22 and 9. The fragment of chromosome 9 that joins the breakpoint cluster (BCR) carries Abelson (ABL) oncogene which forms chimeric gene with the remains of the BCR. This codes for 210 kDa protein with tyrosine kinase activity which may play a causative role in the disease.



Clinical Features

CML presents with tiredness, lethargy, anorexia, weight loss, abdominal fullness, abdominal pain and discomfort due to traction of a massive splenomegaly (spleen often enlarges greater than 15 cm). Splenic friction rub may be heard in cases of splenic infarction.

About 20% are asymptomatic. The following symptoms may denote development of acute phase.

- Fever
- Rapid weight loss
- Recurrence of bone pain or bone tenderness after successful treatment
- Splenic pain
- Signs of infection or bleeding
- Lymphadenopathy
- Cutaneous infiltration
- Meningeal leukaemia



Investigations

1. Normocytic normochromic anaemia
2. Mean WBC count is $220 \times 10^9/l$ (range 9.5 to $600 \times 10^9/L$) or (2–6 lakhs/ μL)

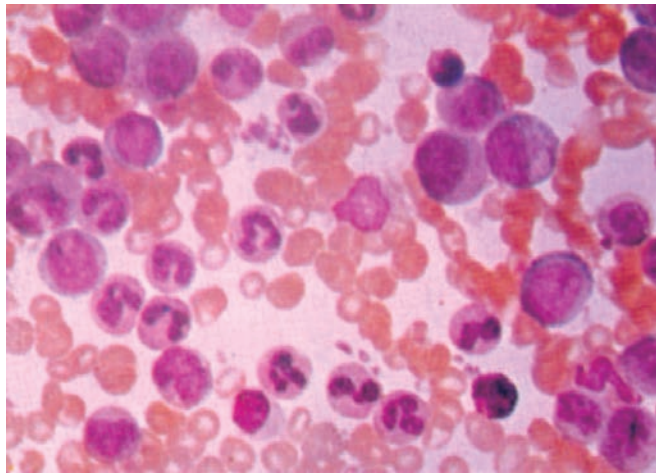

Fig. 6.16: CML-granulocytes in different stages of maturation

3. Mean platelet count is $445 \times 10^9/l$ (range $162-2000 \times 10^9/L$)
4. *Leucocyte alkaline phosphatase*: Absent in granulocytes in CML
5. Plasma uric acid and alkaline phosphatase are increased
6. Serum B_{12} level is increased due to increase in transcobalamin III which is present in neutrophil granules.
7. Bone marrow shows increased cellularity especially myeloid and megakaryocytic (Fig. 6.16).

Marrow and blood show basophilia, eosinophilia and monocytosis.

8. Disease acceleration is denoted by
 - Blasts 10–19% in blood or bone marrow
 - Basophils > 20% in blood or bone marrow
 - Platelets < 100,000/ μ L unrelated to therapy or > 10, 00,000/ μ L unresponsive to therapy
 - Increasing splenic size
 - Increasing WBC count unresponsive to therapy
 - Cytogenetic clonal evolution
 - Progressive anaemia
- Blastic crisis is established by
 - Blasts > 20% in bone marrow or peripheral blood smear
 - Extramedullary blast formation
 - Large foci or clusters of blasts in bone marrow
9. All patients have evidence of translocation by cytogenetics, fluorescent in situ hybridisation (FISH) or by molecular methods.



Management

1. *Allogeneic or syngeneic bone marrow transplant*: It is useful for patients in early chronic phase. In accelera-

ted and blast transformation phases, the response is poor.

2. *Imatinib mesylate*: Imatinib mesylate is an inhibitor of tyrosine kinase activity of BCR-ABL proteins and thereby inducing apoptosis. It produces much better haematologic and cytogenetic responses than the previous standard therapy. Dosage is 400 mg/day PO. Side effects include fluid retention, nausea, muscle cramps, diarrhoea, skin rashes and myelosuppression.

Dasatinib (100 mg/day) and nilotinib are newer tyrosine kinase inhibitors used for all stages of CML with resistance or intolerance to prior therapy including imatinib.

3. *Alpha interferon*: It is given in a dose of 3–9 mega units/day/IM or SC. It causes induction and maintenance of remission in chronic phases of the disease in 70% of patients. It also causes reduction in the percentage of Ph positive cells in 20% and elimination of Ph positive cells in 5% of the patients. Interferon causes flu-like syndrome, weight loss, tiredness, nausea, vomiting, diarrhoea, and headache. In patients who do not tolerate, dose can be reduced to 3 mega units 3 times per week. It should not be given for patients above 75 years because of neurotoxicity.
4. *Chemotherapy with busulphan and hydroxyurea*:
 - a. Busulphan causes severe bone marrow depression and pulmonary fibrosis but has a smoother course. Dose 2–4 mg/day orally in chronic phase of the disease.
 - b. Hydroxyurea in a dose of 2–4 gm per day is gradually tapered when the WBC count comes under control. After sometime, it can be stopped and can be reintroduced when the count rises above $20 \times 10^9/l$ (20,000/ μ L).
5. *Treatment of accelerated phase and blast crisis*: Hydroxyurea is very useful in this stage. When blast transformation occurs, treatment is according to the type of blasts, i.e. whether the type is lymphoblastic or myeloblastic as already described.
6. *Leukapheresis and Splenectomy*: Leukapheresis is useful in emergencies where leucocytes related complications such as pulmonary failure and CVA occur and also in pregnant women. Splenectomy is reserved for painful splenomegaly unresponsive to chemotherapy or for significant anaemia or thrombocytopenia.

Summary

Allogeneic SCT is currently the only curative therapy for CML, when feasible, is the treatment of choice. When HLA matched compatible donor is not available, treat them with imatinib. If major cytogenetic remission occurs



continue imatinib. If imatinib fails to cause cytogenetic remission, manage them with HLA-compatible unrelated donor, IFN- α , autologous SCT and new drugs.

Prognosis

Overall survival is 4-5 years from diagnosis. Fifteen per cent risk of death in the first 12 months and the risk becomes 20-25% annually thereafter. Death seldom occurs during chronic phase. Mean survival is about 3 years. Patients who lack Ph chromosome have a poor prognosis.

Poor Prognostic Factors

Sokal index – for chemotherapy treated patients

- Elderly
- Increased percentage of circulating blasts
- Increased spleen size
- Decreased platelet count
- Cytogenetic clonal evolution

Hasford system – for interferon α treated patients

- Elderly
- Increased percentage of circulating blasts
- Increased spleen size
- Decreased platelet count
- Increased percentage of eosinophils and basophils

Response Criteria in CML

Haematologic:

Complete response

WBC count < 10,000/ μ L with normal morphology.

Normal haemoglobin and platelet count.

Incomplete response

WBC count > 10,000/ μ L

Cytogenetic: Percentage of bone marrow metaphases with t (9; 22)

Complete response 0

Partial response < 35

Minor response 36–85

No response 85–100

Molecular: Presence of BCR/ABL transcript by RT-PCR.

Complete response—none

Incomplete response—Any

Complete haematologic response requires disappearance of splenomegaly.

RT-PCR: Reverse transcriptase – Polymerase chain reaction.

Ph Chromosome Negative CML (5%)

Fifty per cent of the patients who are Ph negative show BCR (breakpoint cluster region) positive in their chromosomes and they behave as Ph positive CML and should be treated accordingly. In the rest, the absolute monocyte count is high and they respond poorly to treatment.

Median survival is less than one year. These patients go in for blast crisis frequently. The response to treatment is poor and they have a very short survival.

Special Clinical Problems in CML

- False platelet counts—It happens because the granulocytes become disrupted and automated platelet counting machine enumerates the large leucocyte granules as platelets.
- Pseudo-hyperkalaemia—Marked thrombocytosis may elevate serum potassium concentration because the platelets release potassium during the clotting reaction.
- Pseudo-hypoglycaemia—Leucocytes metabolise glucose from serum in test tube thereby producing false low values.
- Pseudo-hypoxaemia—Oxidative respiration is used by monocytes and immature leucocytes and therefore false low oxygen tension is seen in patients with severe thrombocytosis or granulocytosis because of oxygen consumption in test tubes.

Acute Lymphoblastic Leukaemia (ALL)

ALL is predominantly seen in children. It constitutes 75% of childhood leukaemias. Peak incidence is seen in 3–7 years. There is increased preponderance for males than females.

Aetiology

1. Radiation
2. Genetic disorders—There is increased predisposition in certain genetic disorders like—Down's syndrome, Bloom's syndrome, Fanconi's anaemia and Ataxia telangiectasia.
3. Viruses—Estein Barr virus, HTLV.

Classification

Majority arise from B-progenitor cells, 20% from T-cells, and 5% from mature B-cells.

FAB Classification (Fig. 6.15)

- L 1 Small round blasts with scanty cytoplasm
- L 2 Pleomorphic large blasts with more cytoplasm and prominent nucleoli
- L 3 Vacuolated cytoplasm with vesicular nuclei

Immunologic subtype	% of cases	FAB-subtype	Cytogenetic abnormalities
Pre-B ALL	75	L 1, L 2	t (9;22), t (4;11), t (1;19)
T-cell ALL	20	L 1, L 2	14q 11, or 7q 34,
B-cell ALL	5	L 3	t (8;14), t (8;22), t (2;8)



Clinical Features

Onset is abrupt and stormy. The duration of symptoms is usually less than four weeks at the time of diagnosis. Fatigue and weakness are common symptoms. Progressive marrow failure leads to pallor, petechiae, bleeding and fever.

Signs

Pallor, petechiae, mucosal bleeding	– 50%
Bone pain, arthralgias, fever	– 25%
Splenomegaly	– 60%

Other signs are hepatomegaly, lymphadenopathy, and signs of increased ICT due to leukaemic infiltration of meninges. Children with T-cell type show anterior mediastinal mass. Testes may be involved. Unusual presentation of ALL includes aplastic anaemia, isolated renal failure, hypoglycaemia, pulmonary nodules, skin nodules and bone marrow necrosis.

Differential Diagnosis

- Idiopathic thrombocytopenia
- Aplastic anaemia
- Infectious mononucleosis
- Pertussis.



Investigations

- Anaemia
- Thrombocytopenia
- WBC count
 - 50%— < 10,000/cmm
 - 20%— > 50,000/cmm
- Peripheral smear shows lymphoblasts
- Bone marrow shows infiltration by malignant lymphoblasts
- Chest X-ray—Mediastinal mass
- Bone X-ray—Altered medullary trabeculae, cortical defects or subepiphyseal resorption.
- CSF analysis for leukaemic cells
- Elevated uric acid value
- Renal function tests to detect renal impairment.



Management

It has four phases:

1. Induction
2. Consolidation
3. Maintenance
4. CNS prophylaxis

Remission Induction: (4–6 weeks)

Vincristine 1.5 mg/m² (maximum 2 mg) IV/week
 Prednisolone 40 mg/m² (maximum 60 mg) PO/day
 L – Asparaginase 10,000 U/m² thrice weekly
 In addition for high risk patients add –
 Daunorubicin 20 mg/m²/week

If normal bone marrow is not achieved in 6 weeks, treatment can be carried out for additional two weeks.

No response at 8 weeks time constitutes induction failure and signifies poor prognosis.

Consolidation: Consolidation is carried out by multiple drug combinations involving drugs like methotrexate, 6-mercaptopurine, high dose cytarabine, and cyclophosphamide.

Maintenance:

6-mercaptopurine 50-75 mg/m²/day
 Methotrexate 20 mg/m²/w

This regimen is usually given for a period of 18 months. Periodic re-induction with other induction drugs is given during this phase.

CNS Prophylaxis: For patients with good prognosis – Intrathecal methotrexate weekly for 5-6 weeks followed by repeat intrathecal methotrexate every 8 weeks for the total duration of maintenance therapy.

For poor risk patients/CNS involvement at the time of presentation, triple therapy (Intrathecal) is advised. Methotrexate, hydrocortisone 12 mg/m², cytosine arabinoside 24 mg/m² with cranial radiation 1800–2000 rads in 12 fractions in over 2-3 weeks.

Poor Prognostic Factors

1. Age < 1 year or > 9 years
2. WBC > 50,000/cmm
3. Mediastinal mass
4. CNS involvement
5. Male sex
6. Late achievement of complete remission
7. L 3
8. Immunophenotype
 - Pro B-cell ALL
 - Pro T-cell, Pre T-cell and mature T-cell ALL
9. t(9;22), t(1;19), t(4;11)
 Abnormal 11q 23 re-arrangement

Hyperdiploidy indicates good prognosis.



Treatment of Relapse

1. Bone marrow relapse – Allogenic bone marrow transplant.

2. CNS relapse – Cranial radiation, triple intrathecal therapy, and systemic therapy.
3. Testicular relapse – Bilateral testicular irradiation and systemic therapy.

Supportive care and antibiotics especially cotrimoxazole given prophylactically reduces overall incidence of infection.

Advised to have adequate hydration and add allopurinol to prevent urate nephropathy.

Chronic Lymphocytic Leukaemia (CLL)

This is the most common variety of leukaemia, with a male: female ratio of 2:1. Patients median age group is above 45 years with a peak around 60 years. CLL constitutes 25% of all leukaemias.

Staging	Median	Survival
Stage 0	Absolute lymphocytosis > $15 \times 10^9/l$ ($15,000/\mu L$)	> 10 yrs
Stage 1	Stage 0 + enlarged lymph nodes	7 yrs
Stage 2	Stage 0 + enlarged liver or spleen or both	7 yrs
Stage 3	Stage 0 + anaemia-non-autoimmune (Hb < 11 gm/dl) \pm stage 1 or 2	3 yrs
Stage 4	Stage 0 + platelets < $100 \times 10^9/l$ or < $100,000/\mu L$ \pm anaemia, organomegaly	3 yrs



Clinical Features

Weight loss, infection, bleeding, enlarged rubbery non-tender nodes, late hepatosplenomegaly.



Investigations

1. *Mild anaemia*: Coombs' positive haemolytic anaemia with warm antibody type may occur.
2. *WBC count*: Between 50 and $200 \times 10^9/l$ or $50,000$ to $200,000/\mu L$ (may be up to $1000 \times 10^9/l$). 95% of the cells are small lymphocytes (Fig. 6.17).
3. Platelet count is low, normal or mildly reduced.
4. Total proteins and immunoglobulin levels are low as B-lymphocytes fail to produce antibodies.



Management

The degree of lymphocytosis is not an indication to initiate therapy. Unless the patient is symptomatic with lymphadenopathy and hepatosplenomegaly, treatment should be withheld.

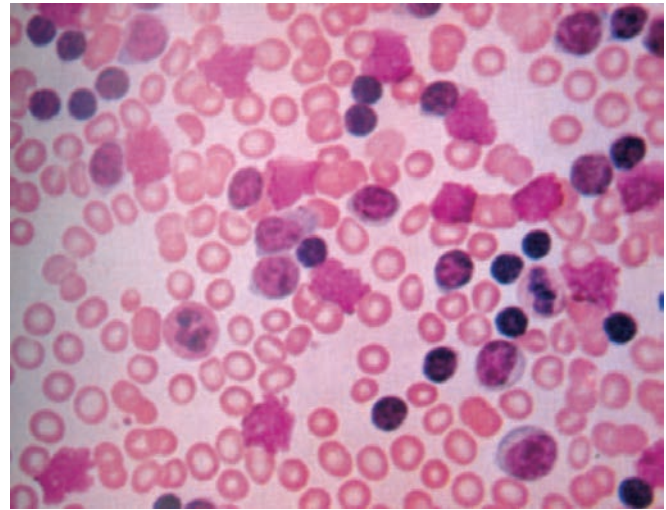

Fig. 6.17: CLL-predominant lymphocytes

Clinical criteria	Management	Prognosis
No anaemia/thrombocytopenia and < 3 areas of lymphoid enlargement	No specific treatment required	Median survival > 12 years
No anaemia/thrombocytopenia + > three areas of lymphoid enlargement	Chlorambucil (5 mg/day orally) in symptomatic patients; local radiotherapy to lymph nodes and to reduce spleen size	5-10 years
Anaemia or thrombocytopenia regardless of the no. of areas of lymphoid enlargement	Red cell transfusion; prednisolone 40 mg/day \times 2-4 weeks in bone marrow failure	2-3 years

Cyclophosphamide: This can be used as an alternative to chlorambucil. Oral doses of 2-3 mg/kg/day for 5 days every 3 weeks for remission induction. IV cyclophosphamide (600 mg/m^2) every 3-4 weeks can also be used.

Autoimmune haemolysis should be managed with steroids and hypogammaglobulinaemia with IV immunoglobulins whether chemotherapy is given or not.

Newer Drugs

1. Fludarabine, 25-30 mg/m² IV daily for 5 consecutive days every 4 weeks, is an excellent second-line therapy.
Fludarabine is preferred in young patients.
2. Cladribine (2-chlorodeoxyadenosine), 0.2 mg/kg IV continuous infusion daily for 7 days every 4 weeks

or 0.14 mg/kg daily over 2 hours for 5 consecutive days every 4 weeks, is also an excellent second-line therapy.

3. Monoclonal antibodies like rituximab and alemtuzumab can be used. Rituximab is continued with first line drugs.
4. In refractory CLL : Alemtuzumab - Fludarabine.

Hairy Cell Leukaemia

It is a lymphoproliferative B-cell disorder, with a male:female ratio of 6 : 1. The cells are characteristically hairy and express CD 25 and FM C7. The acid phosphatase staining reaction in the cells is resistant to the action of tartrate (tartrate resistant acid phosphatase). The neutrophil alkaline phosphatase levels are always high.



Complications

Vasculitis, frequent infections.



Management

Splenectomy was the mainstay of treatment. Nowadays alpha-interferon is used in doses of 3 mega units per day reducing to 3 times a week. Deoxycytosine and 2 chlorodeoxyadenosine (cladribine) are also tried.

- However, a single 7-day course of chlorodeoxyadenosine (cladribine) induces remission in > 90% of patients and 5 year survival exceeds 50%.

Myelodysplastic and Preleukaemic Syndromes (MDS and PLS)

- Disease of elderly (65-70 years) with slight male preponderance.

MDS and PLS are synonyms for a group of clonal disorders of the bone marrow that are characterised by dysmyelopoiesis and peripheral blood cytopenias. They can progress to acute leukaemia or the patient may succumb to complications of the cytopenias.

The primary mechanisms of suppression of normal cell production and replacement by defective cells are responsible for the major signs and symptoms.

Patient may present with anaemia, recurrent infections due to neutropenia and functional impairment of the neutrophils and bleeding manifestations because of thrombocytopenia and functional impairment of platelets.

The abnormal clone of cells progress to produce acute leukaemia because of some secondary change, which

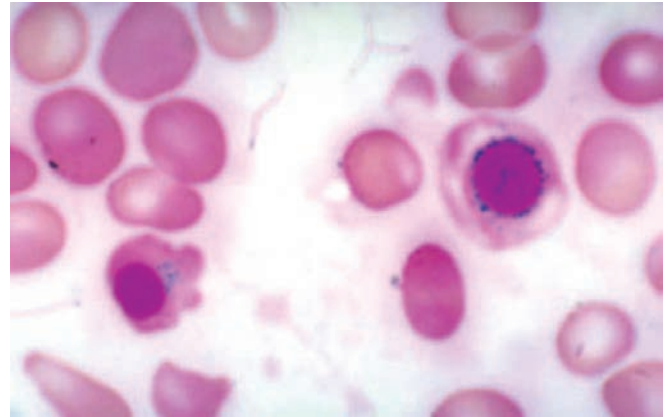

Fig. 6.18: Ringed sideroblasts

may be either due to clonal evolution or due to failure of host defense mechanisms.

Clinicopathologic Forms of MDS/PLS

WHO classification:

1. Refractory anaemia (RA)
2. Refractory anaemia with sideroblasts (RARS)
3. Refractory cytopenia with multilineage dysplasia (RCMD)
4. RCMD with ringed sideroblasts (RCMD-RS) (Fig. 6.18)
5. Refractory anaemia with excess blasts – 1 (RAEB-1)
6. RAEB-2
7. Myelodysplastic syndrome unclassified (MDS-U)
8. MDS with isolated deletions (5q)

The changes in classification by WHO were made due to the following reasons:

- The distinction between RAEB-t and AML seems arbitrary and grouped together as acute leukaemia.
- CMML behaves more like a myeloproliferative disorder and removed it from MDS.
- Separated refractory anaemias with dysmorphic change restricted to erythroid lineage from that with multilineage dysplasia.

Diagnosis

1. *Bone marrow aspiration*: This shows hypercellular marrow with evidence of dysplasia. Blast cells are seen (< 20%).
2. *Chromosome analysis*: This frequently reveals abnormality in chromosomes 5 or 7.

Prognosis

In FAB subtypes, first two conditions have a chronic course and the latter three conditions have an aggressive course and often terminate in acute leukaemia.



Management

Treatment is often unsatisfactory. Conservative therapy is warranted for patients who have a chronic course. If there are life-threatening complications due to cytopenias, aggressive treatment is warranted. Corticosteroid, vitamin B₁₂, folic acid and androgen therapy are ineffective.

Aggressive therapy with antileukaemic agents (low dose cytosine arabinoside 20 mg SC, twice daily) is useful for young patients only and in older patients, this is ineffective.

Amifostine—An organic thiophosphonate that block apoptosis can improve blood counts.

Azacitidine—75 mg/m² daily for 7 days every four weeks (4 cycles)

Decitabine—15 mg/m² by continuous IV infusion every 8 hours for 3 days.

Lenatidomide—A thalidomide derivative used orally 10 mg/day.

Bone marrow transplantation has proved effective in young patients (30% success rate). Recombinant cytokines, erythropoietin, CSF-G, CSF-GM are used to ameliorate the cytopenias. This modality of treatment is expensive.

The Lymphomas

Lymphomas are malignant proliferation of the lymphoid system. They are divided into Hodgkin's and non-Hodgkin's types by histology. NHL accounts for 70% of lymphomas.

Hodgkin's Disease

There is progressive, painless enlargement of lymphoid tissues throughout the body. It occurs equally in both sexes with a slight male preponderance and it has two peaks of incidence, one in adolescence and early adult life and a second at 45-75 years of age.

EB virus involvement is thought to be one of the aetiologies.

Pathological Classification

Types	Prognosis
Lymphocyte predominant	Very good
Nodular sclerosing	Good
Mixed cellularity	Fair
Lymphocyte depleted	Poor

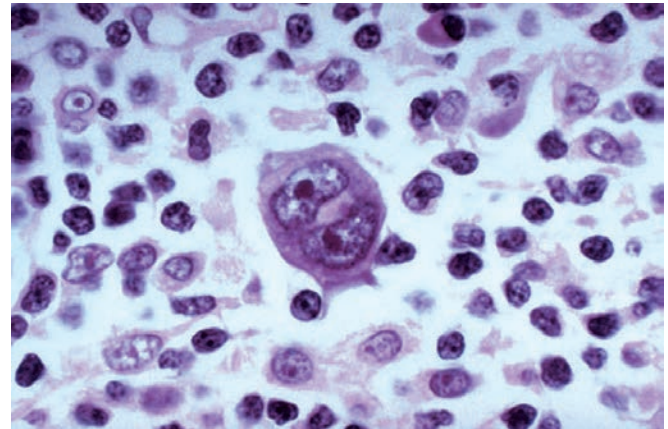

Fig. 6.19: Reed-Sternberg cell

Characteristically, cells with mirror image nuclei (*Reed-Sternberg cells*) are seen (Fig. 6.19).

Nodular lymphocyte predominant Hodgkin's disease is a distinct form from classical Hodgkin. It tends to have a chronic relapsing course and sometimes transforms into diffuse large B-cell lymphoma.



Clinical Features

Patients present with enlarged, painless lymph nodes (cervical 50%, mediastinal 25%, axillary 18%, inguinal 16%, abdominal 9%), alcohol induced pain over the enlarged nodes, and features due to the mass effect of the node. Twenty-five per cent have constitutional symptoms like fever, weight loss, night sweats, and pruritus. Pel Ebstein type of fever (fever alternating with long periods of normal or low temperature) may occur.

Hepatosplenomegaly may also be present.



Investigations

1. Lymph node biopsy may show the characteristic pathological pattern.
2. Bone marrow biopsy may be found to be abnormal later.
3. Liver biopsy may be diagnostic in patients with hepatomegaly.
4. Lymphopenia when occurs indicates a bad prognosis.
5. Moderate eosinophilia may occur in 10-15% of the patients.

Clinical Staging (Ann-Arbor classification)

Stage I Involvement of a single lymph node region (I) or extra-lymphatic site (E)

Stage II	Involvement of two or more lymph node regions (II) or an extra-lymphatic site and lymph node regions on the same side (above or below) of the diaphragm (IIE)
Stage III	Involvement of lymph node regions on both sides of the diaphragm with (IIIE) or without (III) localised extra-lymphatic involvement or involvement of the spleen (IIIS) or both (IIISE)
Stage IV	Diffuse involvement of one or more extra-lymphatic tissues, e.g. liver or bone marrow. The lymphatic structures are lymph nodes, spleen, thymus, Waldeyer's ring, appendix and Peyer's patches.

Each stage is subdivided into A or B depending on the absence or presence of symptoms. The symptoms are weight loss more than 10% for the last 6 months, unexplained fever > 38°C, night sweats (hypercatabolic state).



Management

Radiotherapy

It is indicated for stages IA and IIA. Radiotherapy is indicated also for lesions causing pressure problems. It is also given after chemotherapy to sites where there was originally bulk disease.

Irradiation between 3600 to 4400 cGy is given to contiguous regions of lymphoid tissue.

Radiation Fields

All major sites of lymphoid tissue above the diaphragm-mantle field.

The periaortic and splenic nodes or spleen-spade field.

Periaortic and splenic field including the iliac, hypogastric and inguinal nodes-inverted Y field.

Poor Prognostic Indicators for Radiotherapy

1. A mediastinal mass greater than one-third of the chest diameter
2. Age greater than 40
3. "B" symptoms
4. Extranodal disease, 2-4 or more lymph node sites
5. ESR over 30 mm/hr
6. Male sex
7. Mixed cellularity in histology.

Chemotherapy

Combination chemotherapy is helpful for obtaining lasting remissions.

Indications for Chemotherapy

1. All patients with B symptoms
2. Stage II disease with more than 3 areas of involvement
3. Stage III and stage IV disease.

Chemotherapy is usually given with MOPP and MVPP regimens which employ mustine hydrochloride as the alkylating agents.

MOPP— Mustine, Oncovin (Vincristine), Procarbazine, Prednisolone

MVPP— Mustine, Vinblastine, Procarbazine, Prednisolone

ChIVPP— Chlorambucil, Vinblastine, Procarbazine, Prednisolone

All regimens cause myelotoxicity. There is a small risk of development of acute leukaemia, 7-10 years later.

ABVD— Adriamycin, Bleomycin, Vinblastine, Dacarbazine regimen do not carry the risk of development of acute leukaemia.

Prognosis

Five-year survival rate in stage IA is 90% and in stage IIA, it is more than 70%. Patients who relapse while on therapy have a poor prognosis. In such cases autologous bone marrow transplantation may be tried if bone marrow is free.

Non-Hodgkin's Lymphoma (NHL)

There is a malignant monoclonal proliferation of lymphoid cells (majority of B-cells and minority of T-cells).

Working Classification

Three grades (low, intermediate, high).

Staging by Ann-Arbor Classification

Stage I	Involvement of a single lymph node region or a single extra-lymphatic organ or site
Stage II	Involvement of 2 or more lymph node regions on the same side of the diaphragm
Stage III	Involvement of lymph node regions on both sides of the diaphragm
Stage IV	Diffuse or disseminated involvement of one or more extra-lymphatic organs.



Clinical Features

Commonly presents with lymphadenopathy; may also be symptomless; infection is common; systemic symp-

toms as in Hodgkin's lymphoma. B-symptoms may be present. However, they are not useful in predicting the prognosis. If the nodes are more than 10 cm, the disease is advanced. It warrants ENT and GIT examination since lymphomas of both sites often co-exist.



Investigations

1. Lymph node biopsy under CT guidance
2. Laparotomy may be required for diagnostic purposes in cases of inadequate samples
3. *Bone marrow biopsy*: Bone marrow involvement indicates stage IV disease
4. Positive Coombs' test in the presence of complicating hemolytic anaemia
5. Test for HIV since it may also present with generalised lymphadenopathy.



Management

1. Radiotherapy
2. Chemotherapy (usually single drug is used).

In low grade lymphomas

- a. Radiotherapy is used for stage I and II A.
- b. Single agent chemotherapy for stage IIB, III and IV.
Chlorambucil 20 mg/m²/day for three days every month. Once response is achieved, therapy is discontinued for a number of years. Relapse can also be treated in the same way. When there are more primitive lymphocytes, combination chemotherapy is used.
- c. Interferon has also been tried.
- d. Autologous bone marrow transplant has been done on experimental basis.
- e. Rituximab induces an objective response in 50% of patients with follicular lymphoma without the usual toxicities of chemotherapy.

In high grade lymphomas

- a. Stage I disease is treated with radiotherapy.
- b. Stage II, III and IV diseases are treated with intensive combination chemotherapy.

CHOP regimen is used here (cyclophosphamide, adriamycin, vincristine and prednisolone).

Prognostic Factors in Diffuse Aggressive Lymphoma

Features	Good prognosis	Bad prognosis
Age	< 60 years	> 60 years
Stage	I or II	III or IV
Number of extranodal sites	0 or 1	more than 1
LDH	< normal	> normal

Survival Rate—Diffuse Large B-cell Lymphoma

	Localised disease	Disseminated disease
Characteristics	Stage I or II Small tumour volume Good prognostic factors	Stage III or IV Localised but bulky tumour Bad prognostic factors
Complete response	> 80%	50%
Relapse	< 20%	40%
10 year survival	70-80%	30%

Clinical Differences between Hodgkin's and Non-Hodgkin's Lymphomas

Hodgkin's disease	Non-Hodgkin's lymphomas
1. Cellular derivation-unresolved	90% B-cell; 10% T-cell; Rarely monocytic
2. Localised to a single group of nodes (cervical, mediastinal, para-aortic)	Involvement of multiple peripheral nodes
3. Spreads by contiguity	Noncontiguous spread
4. Mesenteric nodes and Waldeyer's ring rarely involved	Commonly involved
5. Extranodal involvement-uncommon	Common
6. Bone marrow involvement-uncommon	Common
7. Chromosomal translocation- yet to be described	Common
8. Curability > 75%	< 30-40%

Lymphoma—Pregnancy

Problems

- Aggressive histology of tumour with poor maternal prognosis
- Need for immediate efficacious treatment
- Adverse effect of chemotherapy/radiation on the foetus



Management

First trimester: Terminate pregnancy and advocate standard therapy.

Second and third trimester: No drug toxicity for the foetus. Advocate standard regimens and the outcome will be identical to non-pregnant women.

- Delay the treatment until delivery for indolent lymphomas.
- Do not use CT scan or isotopes for staging.

Plasma Cell Dyscrasias

These are a group of disorders characterised by the expansion of a single clone of immunoglobulin (Ig)

secreting cells and are associated with increase in levels of homogenous Ig or its fragments.

Examples of Monoclonal Gammopathies

1. Multiple myeloma
2. Waldenstrom's macroglobulinemia
3. Heavy chain disease (γ , α , μ)
4. Primary or immunocyte associated amyloidosis
5. Monoclonal gammopathy of undetermined origin (benign IgG, IgA, IgD, IgM, and rarely free light chains, biconal gammopathies, idiopathic Bence-Jones proteinuria).

Multiple Myeloma

It is a malignant neoplasm of plasma cells.

Incidence : 5/100,000

Peak age group : 60 years and above

Multiple myeloma is characterised by the appearance of M protein in the serum and/or urine.

IgG 55%

IgA 25%

Light chain disease 20% (No serum M component; only Bence-Jones proteinuria)

Immunopathology

Bone marrow is infiltrated with aggregates of abnormal plasma cells (Fig. 6.20). The neoplastic plasma cells are mature or immature leading to multifocal destructive bone lesions.

In myeloma, the transformation of B-lymphocytes to plasma cells manufacturing immunoglobulins is defective resulting in the production of abnormal monoclonal immunoglobulin. Hence, the immunity is also defective.



Clinical Features

There is a long preclinical phase, extending up to 25 years. Symptoms due to bone marrow infiltration are pain, pathologic fracture and hypercalcemia (confusion, weakness, lethargy, constipation and polyuria). Recurrent infections and symptoms due to hyperviscosity syndrome are common. Renal insufficiency occurs in up to 50% of the patients due to interstitial infiltrates of chronic inflammatory cells, protein casts consisting of albumin, immunoglobulin and Tamm-Horsfall protein, metastatic calcifications and pyelonephritis.



Complications

1. Hypercalcaemia
2. Hyperuricaemia

3. Renal failure
4. Infections
5. Skeletal-pathological fractures
6. Hyperviscosity syndrome
7. Spinal cord compression.

Variant Forms of Myeloma

1. Smouldering myeloma (SMM M-protein level > 3 gm/dL in the serum, >10% atypical plasma cells in the bone marrow but no anaemia, renal insufficiency or skeletal lesions).
2. Plasma cell leukaemia (> 20% plasma cells in the peripheral blood and absolute plasma cell count is around 2000/mL).
3. Nonsecretory myeloma (no M-protein in the serum or in the urine).
4. IgD myeloma (M-protein is smaller, and Bence-Jones proteinuria is of gamma type. Extramedullary plasmacytomas, plasma cell leukaemia, and amyloidosis are common).
5. Osteosclerotic myeloma (associated with the acronym **POEMS**-Polyneuropathy, Organomegaly, Endocrinopathy, M-protein, Skin changes).
6. Solitary plasmacytoma.



Investigations

Diagnosis of myeloma requires the detection of at least two of the following abnormalities:

1. Monoclonal Ig light chains in blood or urine
2. Infiltration of bone marrow with malignant plasma cells
3. Osteolytic bone lesions.

Minimal criteria for the diagnosis of multiple myeloma include (Figs 6.20 and 6.21):

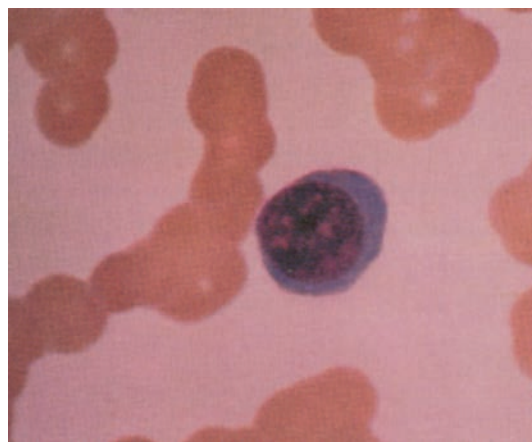

Fig. 6.20: Multiple myeloma-plasma cell and excessive rouleaux formation

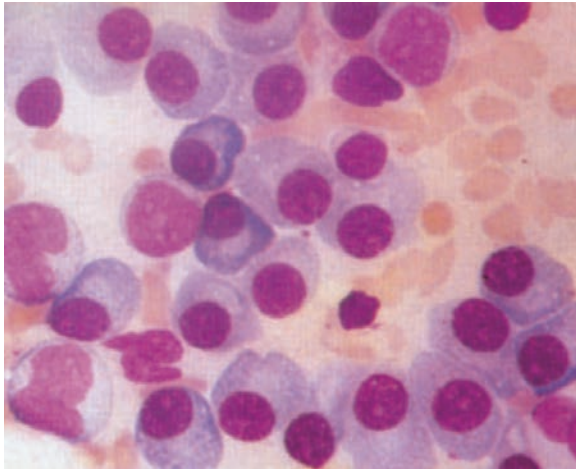

Fig. 6.21: Multiple myeloma-myeloma cells and blast cells in bone marrow'

1. The presence of at least 10% abnormal, immature plasma cells in the bone marrow, or
2. Histologic proof of an extramedullary plasmacytoma
3. The usual clinical features of multiple myeloma.

Along with the above mentioned features if at least one of the following abnormalities are present, multiple myeloma is diagnosed.

- a. An M-protein in the serum > 3 gm/dL (Fig. 6.22)
- b. M-protein in the urine
- c. Osteolytic lesions.

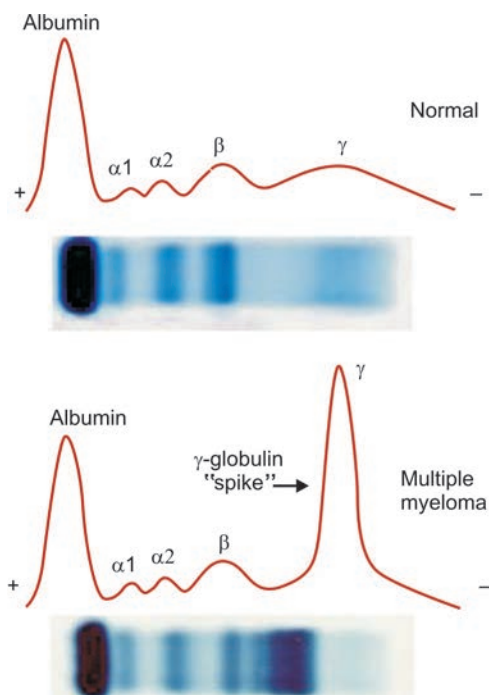

Fig. 6.22: Serum electrophoresis



Fig. 6.23: Pathological fracture in myeloma patient

Other investigations are:

1. Renal function tests (blood urea, creatinine, electrolytes)
2. Blood calcium and albumin (hypercalcaemia)
3. X-ray and isotope bone scan (bone fracture) (Fig. 6.23)
4. Plasma Ig level (degree of immune paresis)
5. Blood count and reticulocyte count (degree of marrow failure)
6. Bleeding time and coagulation screen (to ascertain degree of haemostasis)
7. Serum β_2 microglobulin to find out disease activities.

Monoclonal gammopathy of undetermined significance (MGUS) also resembles multiple myeloma. The former condition is characterised by an M-protein level less than 3 gm/dL in the serum, less than 10% plasma cells in the bone marrow, no anaemia or osteolytic bone lesions, normal serum albumin, nil or small amounts of M-proteins in the urine, and no evidence of progression. Patients with MGUS should be observed indefinitely. No treatment is needed.

Exclusion Criteria—Multiple Myeloma

- Connective tissue disorders
- Chronic infection
- Carcinoma
- Lymphoma

Myeloma Staging System

Stage	Criteria	Estimated tumour burden $\times 10^{12}$ cells/m ²
I	All of the following: 1. Haemoglobin > 10 g/dL 2. Serum calcium < 12 mg/dL 3. Normal bone X-ray or solitary lesion 4. Low M-component production a. IgG level < 5 g/dL b. IgA level < 3 g/dL c. Urine light chain < 4g/24 h	< 0.6 (Low)
II	Fitting neither I nor III	0.6–1.20 (intermediate)
III	One or more of the following: 1. Haemoglobin < 8.5 g/dL 2. Serum calcium > 12 mg/dL 3. Advanced lytic bone lesions 4. High M-component production a. IgG level > 7 g/dL b. IgA level > 5 g/dL c. Urine light chains > 12 g/24 h	> 1.20 (High)
Level	Stage	Median survival (Months)
Subclassification based on serum creatinine levels		
A. < 2 mg/dL	I A	61
B. > 2 mg/dL	II A, B	55
	III A	30
	III B	15
Staging based on β_2 – Microglobulin levels		
< 3.5 μ g/mL—Albumin > 3.5	I (28%)	62
< 3.5 μ g/mL—Albumin < 3.5		
or β_2 M > 3.5 to 5.5 μ g/mL	II (39%)	44
> 5.5 μ g/mL	III (33%)	29
β_2 – Microglobulin level is the single most powerful tool in prediction of prognosis and can replace staging.		

Indications for Treatment

- Elevated M protein in the serum
- Elevated M protein in the urine
- Decreased haemoglobin level
- Increased calcium or creatinine
- Lytic bone lesions
- Extramedullary plasmacytoma



Management

1. Patients should be given at least 3 litres of fluid daily to preserve normal renal function. Serum β_2 microglobulin level < 4 mg/L and free light chains < 0.1 unit per gram creatinine in the urine are indicators of normal renal function. High fluid intake also helps in relieving hypercalcaemia.
2. Pamidronate 15-30 mg slow IV infusion helps in lowering serum calcium.

3. Allopurinol 300 mg orally daily to prevent excessive formation of uric acid.
4. *Chemotherapy.*

Indications for Chemotherapy

- a. Stage II or III disease
- b. Stage I patients exhibiting Bence-Jones proteinuria, progressive lytic lesions, vertebral compression fractures, recurrent infections or rising serum M component.

Primary Chemotherapy

- Various options are available. Conventional ones are:
- A. Melphalan 10 mg/m² PO on days 1-4 and prednisolone 60 mg/m² PO on days 1-4 for a cycle frequency of 4-6 weeks.
 - B. VAD – cycle frequency is 4 weeks.
Vincristine 0.4 mg/m² IV for 4 days
Adriamycin (Doxorubicin) 9 mg/m² IV for 4 days
Dexamethasone 40 mg PO on days 1-4, 9-13, and 17-21.
 - C. Dexamethasone alone 40 mg PO 1-4 days every other week.
 - D. Thalidomide—Start at a lower dose 100 mg/day PO and escalate to 400 mg PO daily at night. This drug can be used with or without dexamethasone.
 - E. Bortezomib (Velcade)—A proteasome inhibitor that degrades ubiquitinated proteins has recently been used. Adverse effects are thrombocytopenia and neuropathy.

Duration of Therapy

Patients should be treated until a plateau phase (stabilisation of M protein levels for several months) is achieved. Once the patient is stabilised follow either one of the schedules:

- Observation without further therapy until disease progression occurs
- Maintenance therapy with oral prednisolone
- High dose regimen with SCT

For patients in whom disease progresses following therapy, Cyclophosphamide along with VAD, thalidomide, and bortezomib or arsenic trioxide can be tried.

Prognosis

The median survival is around 2-3 years with treatment. Fifty per cent of patients are alive for 2 years.

Poor Prognostic Indicators

- a. Hb < 7 gm/dL
- b. Severe hypoalbuminaemia
- c. Intractable renal failure (urea > 10 mmol/l or 60 mg/dL)

- d. Thrombocytopenia
- e. High β_2 microglobulin levels
- f. Plasma cell leukaemia
- g. Bence-Jones proteins > 6 mg/dl of urine
- h. Multiple bony lesions.
- i. S calcium > 12 mg%

Other causes of Bence-Jones proteinuria

1. Primary amyloidosis
2. Waldenström's macroglobulinaemia
3. Malignant lymphoproliferative disorders
4. Idiopathic Bence-Jones proteinuria.

Idiopathic Bence-Jones proteinuria: In this condition, there is excretion of small amounts of monoclonal light chains in the urine. Most patients who excrete upto 1 gm of B-J protein per day may progress to develop multiple myeloma or amyloidosis even after 20 years and hence they have to be observed regularly and indefinitely.

Biclonal or triclonal gammopathies: It can occur in 3-4% of patients with monoclonal gammopathy. IgG and IgA are the most frequent combinations. In two-thirds of patients, the biclonal gammopathies are of unknown significance. In the remainder multiple myeloma, amyloidosis, lymphoproliferative disorders, macroglobulinaemia are common. Immunoelectrophoresis or immunofixation is the diagnostic methods available.



Differential Diagnosis of Polyclonal Gammopathies

1. Connective tissue (autoimmune) diseases
2. Chronic liver disease-especially chronic active hepatitis
3. Chronic infections
4. Lymphoproliferative diseases
5. Normal persons.

An Approach to Bleeding Disorders



History

If a patient presents with bleeding, history should be taken carefully regarding the following:

1. *Site of bleeding:* Muscle and joint bleeding indicates coagulation disorder whereas superficial bleeding (purpura), epistaxis or GI bleeding suggest platelet disorder.
2. *Duration:* Duration gives an idea whether disease is congenital or acquired.

3. *Precipitating factors:* If there are no precipitating factors and if the bleeding occurs spontaneously, it suggests a severe disease.
4. History of previous operations, dental extraction, etc. is useful to find out if there is any antecedent bleeding disorder.
5. *Family history:* It is helpful to rule out genetically transmitted diseases like haemophilia.
6. History of hepatic or renal failure, paraproteinaemia or a collagenosis which may present with bleeding.
7. *History of drug intake:* NSAIDs particularly aspirin inhibit platelet function for upto 10 days following a single tablet ingestion.

Examination

Look for

- a. Bruises, purpura, scars, telangiectasia of lips and tongue (hereditary haemorrhagic telangiectasia)
- b. Examination of joints (haemophilia)
- c. Stigmata of liver disease
- d. Splenomegaly (thrombocytopenia due to hypersplenism).



Investigations

1. *Platelet count:* Normal count $150-350 \times 10^9/l$ (150,000-350,000/ μ L). In congenital and acquired thrombocytopenia, the count is low.
2. *Bleeding time:* Normal bleeding time is < 8 min; In thrombocytopenia and in other platelet disorders, bleeding time is prolonged.

It is a clinical test which assesses platelet endothelial interaction without involving the clotting mechanism.

Ivy's method for BT: Place a cuff around the upper arm and inflate to 40 mm Hg. After cleaning the forearm make two puncture marks in the skin with a standard lancet, taking care to avoid damaging superficial veins. Remove the blood oozing from the wound every 15 seconds with filter paper without pressing on the skin until bleeding ceases.

Normal: < 8 minutes. Take the average of two experiments.

3. *Prothrombin time (PT):* It indicates the integrity of extrinsic coagulation pathway. Normal PT is 12-14 seconds. Prothrombin time is prolonged in factors II, V, VII, X deficiency, liver disease, warfarin therapy and DIC.

When the prothrombin time is used for diagnosis as a screening test, values obtained above the reference range will be further investigated with specific quantitative assays as clinically indicated.

When the PT is used for therapeutic monitoring of oral anticoagulants, the lack of standardisation is a more serious problem. Therefore, calculation of INR is a method of standardisation to avoid these complications and helps in comparison to standard values.

INR only has meaning for patients on a stable dose of anticoagulants and on treatment for at least one week.

Guidelines for anticoagulants – Target levels for INR Disorders

Disorders	INR
1. Atrial fibrillation	2-3
2. Above knee DVT	2-3
3. Pulmonary embolism	2-3
4. Recurrent embolism	3.5
5. Prosthetic heart valves	3-4.5

Excessive anticoagulation

- INR < 6—Reduce the dose of drug or omit the drug
- INR 6-8—Stop the drug and start when INR < 5
- INR > 8—Stop the drug and give 1-2.5 mg vitamin K
- Major bleed—Stop the drug and give prothrombin complex concentrate or fresh frozen plasma along with vitamin K 5 mg IV.

Duration of therapy—Anticoagulants

1. Situational DVT	6 weeks to 3 months
2. Idiopathic DVT	3-6 months
3. Recurrent idiopathic DVT	12 months
4. VTE with ongoing risk factors	Long term/Indefinite
5. Pulmonary embolism	6 months
6. Massive pulmonary embolism	Long term/Indefinite
7. Valvular heart disease with poor LV systolic function	Long term/Indefinite
8. AF/Age > 75 years/H/O embolism	Long term/Indefinite
9. MI with LV dysfunction/LV thrombus	Long term/Indefinite
10. Cardiomyopathy with LV thrombus	Long term/Indefinite
11. MI with good LV function	Maximum 3 months
12. Prosthetic valve	Long term/Indefinite

4. *Activated partial thromboplastin time (PTT)*: It indicates the integrity of intrinsic coagulation pathway. Normal PTT is 30-40 seconds. PTT is prolonged (60-85 sec) in deficiency of factors II, V, VIII, IX, X, XI, haemophilia A and B, von Willebrand's disease and DIC.
5. *Fibrinogen level*: Normal level is 1.5-3.0 gm/dl. The level is low in congenital hypofibrinogenaemia.

6. *Clot retraction time*: Abnormal prolongation of clot retraction time indicates platelet function defects like Glanzmanns thrombasthenia, Bernard-Soulier syndrome, etc.
7. *Activated clotting time*: ACT is similar to aPTT except that fresh whole blood is used (rather than citrated plasma used in aPTT). Normal range: 70-120 seconds. This test is used to monitor heparin anticoagulation. Most patients with lupus anticoagulants that prolong the aPTT have a normal ACT.
8. *Plasma thrombin time*: It tests the time taken for fibrinogen conversion to fibrin. It indirectly measures plasma fibrinogen concentration and it is prolonged in the following conditions:
 - Afibrinogenaemia
 - Hypofibrinogenaemia
 - Therapeutic or circulating anticoagulants
 - Inherited dysfibrinogenaemias.

Bleeding Disorders

Bleeding may occur as a result of qualitative or quantitative defects in platelets.

Qualitative Platelet Disorders

1. *Congenital*
 - a. Disorders of membrane glycoproteins (thrombasthenia, Bernard-Soulier syndrome)
 - b. Disorders of platelet secretion of ADP/prostaglandins (storage pool disorders)
 - c. Defective platelet aggregation (platelets fail to aggregate with ADP, collagen, epinephrine or thrombin).
2. *Acquired*
 - a. Drugs
 - i. NSAIDs (aspirin, indomethacin)
 - ii. Antibiotics (penicillins, cephalosporins)
 - iii. Heparin
 - iv. Beta-blockers
 - v. Dextran
 - b. Uraemia.

Quantitative Platelet Disorders

Thrombocytopenia: Spontaneous bleeding occurs when the platelet count falls below $30 \times 10^9/L$ unless the function is also compromised, e.g. NSAID intake.

Platelet count > 60,000	No bleeding
30,000-60,000	Bleeding with trauma
< 30,000	Spontaneous bleed



Causes

- Decreased production of platelets
Marrow failure
 - Hypoplasia of the marrow (idiopathic, or drug induced)
 - Megaloblastoses (B_{12} or folate deficiency)
 - Infiltration of the bone marrow (leukaemia, myeloma, carcinoma).
- Decreased platelet survival:
 - Immune thrombocytopenic purpura (ITP)
 - Viral infections (HIV)
 - DIC
 - Drugs (quinine, quinidine, methyl dopa)
 - SLE
 - Lymphoma
 - Thrombotic thrombocytopenic purpura (TTP)
- Platelet sequestration (hypersplenism)
- Defective platelet aggregation (aspirin, heparin)
- Dilutional (massive blood transfusion).

Immune Thrombocytopenic Purpura (ITP)

It is an autoimmune disorder due to the presence of autoantibodies directed against platelet membrane glycoprotein IIb and IIIa resulting in premature removal of platelets by macrophage monocyte system. Sometimes the reaction is immune complex mediated.



Clinical Features

In children: Typically presents 2-3 weeks after a viral infection with sudden onset of purpura, nasal or oral bleeding.

In adults: ITP involves females more commonly and has an insidious onset. Symptoms and signs of collagen vascular disorders (like rheumatoid arthritis) may be present. The course is chronic with remissions and relapses.

Presence of splenomegaly does not favour the diagnosis of ITP.



Investigations

- Blood film shows decreased platelet count
- Bone marrow shows increase in megakaryocytes.



Management

In children, the disease is usually self-limiting within a few weeks.

- If the platelet count is $< 10 \times 10^9/L$, prednisolone 2 mg/kg/day is given till the count rises (i.e. within 2-3 days)
- Bleeding from nose, GIT, retinal haemorrhages, intracranial bleeding should be treated accordingly (platelet or fresh blood transfusion)
- Intravenous immunoglobulin for fresh bleeding persisting for a few days following steroid introduction.

Treatment in adults:

- Prednisolone 1 mg/kg/day till the platelet count rises but the response is less rewarding.
- Persistent or life-threatening bleeding should be treated accordingly (platelet or fresh blood transfusion).
- Intravenous IgG (1 gm/kg) should be given if the patient has haemorrhage or if there is life-threatening bleeding. It acts by blocking monocyte-macrophage Fc receptors.
- Relapse is treated by increasing prednisolone dose.
- Splenectomy is considered if there are two relapses. Pneumococcal, meningococcal and *H. influenzae* vaccination should be given subcutaneously before splenectomy. Splenectomy is curative in 70% of the patients.

If the patient responds to prednisolone, a large dose should be given preoperatively to raise the platelet count over 50,000/ml.

If he does not respond to steroids, a 5-day course of gamma globulin IV, 0.4 gm/kg body weight/day, can be used to raise platelet count transiently.

If there is no response, a platelet transfusion (2 units/10 kg of body weight) may be given at the time of intubation for anaesthesia.

- If splenectomy fails, long-term maintenance with prednisolone 5 mg/day should be given.
- If bleeding persists, despite splenectomy, vincristine 2 mg IV weekly for 3 doses, small dose of steroids, danazol 200 mg PO qid, cyclophosphamide 2 mg/kg/day PO, or immunoglobulin infusions 0.4 gm/kg IV daily for 5 days should be considered.

ITP in Pregnancy

It is difficult to differentiate from gestational thrombocytopenia, pre-eclampsia, and HELLP (haemolysis, elevated liver enzymes, low platelets) syndrome and is a diagnosis of exclusion

- Treatment is similar to non-pregnant ITP and are reserved for platelet counts $< 30,000/\text{microlitre}$ or bleeding complications.
- They can safely undergo vaginal delivery or caesarean section if the platelet count is $> 50,000/\text{microlitre}$.

- Platelet transfusion for patients with a platelet count < 10,000/microlitre or bleeding episodes.
- Since most antiplatelet antibodies are IgG and are able to cross the placenta, 5% of neonates are likely to have severe thrombocytopenia and at risk for intracranial haemorrhage.

Thrombotic Thrombocytopenic Purpura (TTP)

TTP is characterised by thrombocytopenia, microangiopathic haemolytic anaemia, increased LDH levels, fever, transient neurologic deficits and renal failure. This is due to widespread hyaline microthrombi found in arterioles and capillaries.

Pathogenesis—Due to antibodies to ADAM TS-13

Causes include:

1. Pregnancy
2. Metastatic cancer
3. HIV infection
4. High dose chemotherapy
5. Mitomycin C
6. Antiplatelet agents like ticlopidine.

The presence of severe Coombs' negative haemolytic anaemia with fragmented RBC in peripheral smear, thrombocytopenia and minimal activation of coagulation confirms the diagnosis.

Patient presents commonly in fourth decade. TTP is treated with corticosteroids, platelet aggregation inhibitors and exchange transfusions. Plasma exchange removing 40 ml/kg body weight of plasma and replacement with an equal volume of fresh frozen plasma daily until platelet count rises to 1,00,000/ μ L with decrease in LDH.

Platelet infusion is contraindicated because it promotes microthrombi formation. Immunomodulatory therapies have been reported to be successful in refractory or relapsing TTP. Immunosuppression with cyclophosphamide, azathioprine, or vincristine may be beneficial.

Rituximab, an anti-CD20 monoclonal antibody has proved to induce remission.

Splenectomy is performed in those who show minimal improvement.

Microangiopathic Haemolytic Anaemia

The microangiopathic haemolytic anaemias are mechanical haemolytic anaemias in which the red cell fragmentation is due to contact between red cells and the abnormal intima of partly thrombosed, narrowed, or necrotic small vessels.

Causes

- Haemolytic uraemic syndrome
- Thrombotic thrombocytopenic purpura
- Disseminated intravascular coagulation
- Disseminated carcinoma
- Malignant hypertension
- Eclampsia
- Immune disorders—SLE, scleroderma, polyarteritis nodosa, Wegener's granulomatosis, acute glomerulonephritis, renal transplant rejection
- Haemangiomas.

HIT-Heparin Induced Thrombocytopenia (White Clot Syndrome)

- Thrombocytopenia develops between 5-14 days after heparin therapy.
- Platelet count falls below 100,000/ μ L or > 50% decrease from the original count.
- More common with unfractionated heparin than with LMWH.
- Platelet count fall that begins before day 5 of heparin therapy is unlikely to be HIT except in cases of heparin exposure within 3 months.
- 3-5% patients exposed to unfractionated heparin develop this complication.
- HIT—An immunoglobulin mediated complication—Antibody formation to platelet factor 4 (PF4) and heparin (Fig. 6.24).
- In HIT, thrombocytopenia resolves within 3-7 days of heparin withdrawal.
- HIT markedly increases the risk of thrombosis rather than bleeding.
- Venous thrombosis is more common than arterial.
- In HIT, thrombotic tendency can last for 30 days.
- 10-20% of patients who generate HIT-IgG develop skin lesions at the site of heparin injection. Majority of these patients do not develop thrombocytopenia. Some of these patients develop skin lesions and thrombocytopenia and they appear to be at very high risk for arterial thrombosis.

Diagnosis

Detection of antibodies—antiheparin/PF4 by ELISA.

Diagnostic algorithm for HIT—4 Ts:

1. Thrombocytopenia
2. Timing of platelet count drop
3. Thrombosis
4. Thrombocytopenia—Exclude other evident causes.



Treatment

- Stop heparin.

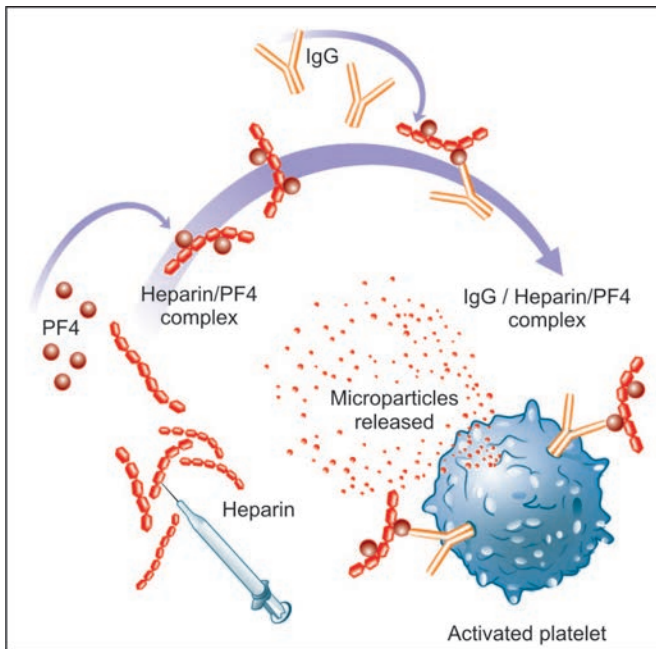

Fig. 6.24: Pathogenesis—Heparin induced thrombocytopenia

- Do not give platelet transfusion.
- Evaluate for deep vein thrombosis.
- Use alternative anticoagulants such as lepirudin, argatroban, bivalirudin, danaparoid or fondaparinux.

Lepirudin (Recombinant hirudin). It is a direct thrombin inhibitor that is used for the treatment of HIT. The drug is given as bolus 0.4 mg/kg followed by 0.15 mg/kg/hour as continuous IV infusion. No drug is available for reversal of its effect. Dose modification is essential in renal insufficiency.

Argatroban is a synthetic direct thrombin inhibitor that is used for HIT therapy.

Reversal agent is not available. The drug is given as IV infusion 2 mcg/kg/minute and not to exceed 10 mcg/kg/minute. The drug is cleared by the liver and dose modification is required in hepatic dysfunction. Warfarin dose has to be adjusted with frequent estimation of INR when argatroban is infused.

Disorder due to Deficiency of Clotting Factors

HAEMOPHILIA A

Reduction of factor VIII results in haemophilia A.

Incidence: 1/10,000 persons

Factor VIII is synthesised by the liver primarily and also by spleen, kidney and placenta. It is bound to the von Willebrand factor (vWF).

The normal factor VIII gene has been cloned and used for treating patients. Haemophilia is a X-linked disorder. All daughters of haemophiliacs are obligate carriers and sisters have a 50% chance of being a carrier. If a carrier has a son, he has a 50% chance of having haemophilia and a daughter has a 50% chance of being a carrier.

Females can be haemophiliacs when

1. She is born to an affected father and a carrier mother (25%)
2. She has a defective gene with Turner's syndrome (45 XO)
3. When lyonisation (inactivation of normal X-chromosome) has occurred.



Clinical Features

The normal factor VIII level is 50-100% (0.5-1.5 U/mL) and is usually measured by a clotting assay. If factor VIII level is < 2%, patient presents with recurrent, spontaneous haemarthrosis which later leads to osteoarthritis, muscle haematomas involving calf and psoas muscles (it may lead to compression of femoral nerve and paraesthesia in thigh and weakness of the quadriceps and contraction and shortening of the Achilles tendon).

If factor VIII level is 2-10%, mild trauma or surgery may cause haematomas. If the factor VIII level is 10-50%, major injury and surgery may cause excessive bleeding.



Complications

1. Arthropathy
2. Muscle atrophy (due to haematomas)
3. Mononeuropathy (compression by haematomas)
4. Risk of hepatitis (A, B, C, D) and HIV through blood and blood product administration.



Management

1. Bleeding episodes are treated by factor VIII concentrate infusion (from donor plasma) which can be stored in domestic refrigerators at 4°C. This should be tested for hepatitis and HIV antibodies.

Development of factor VIII antibodies may result in failure in 20% of patients.

In those patients, porcine factor VIII, infusions of activated clotting factors, e.g. VIIa, FEIBA (factor eight inhibitor bypassing activity), activated concentrate of factors II, IX and X may stop bleeding.

2. IV desmopressin 0.3 mg/kg, can be given to raise factor VIII level to three to five fold. This can be given to cover minor surgeries like dental extraction

Classification of von Willebrand's and Laboratory Abnormalities

Features	Type I	Type IIA	Type IIB	Type IIC	Type III
Genetic transmission	Autosomal dominant	Autosomal dominant	Autosomal dominant	Autosomal recessive	Autosomal recessive
Bleeding time	Prolonged	Prolonged	Prolonged	Prolonged	Prolonged
VIII-C	Decreased	Decreased or normal	Decreased or normal	Normal	Markedly decreased
vWF	Decreased	Decreased or normal	Decreased or normal	Normal	Markedly decreased or absent
Ristocetin cofactor	Decreased	Markedly decreased	Decreased or normal	Decreased	Absent
Ristocetin induced platelet aggregation (RIPA)	Decreased or normal	Absent or markedly decreased	Increased	Markedly decreased	Absent
Multimeric structure	Normal in plasma and platelets	Absence of large and intermediate multimers from plasma and platelets	Absence of only large multimers from plasma; normal in platelets	Absence of large multimers from plasma and platelets; triplet structure aberrant	Variable

and can be repeated 6-8 hours later (tachyphylaxis occurs with subsequent injections).

3. Surgery can be done with adequate doses of factor VIII concentrate and along with a 10 day course of tranexamic acid (a fibrinolytic inhibitor) and an antibiotic.
4. Physiotherapy.
5. Avoid intramuscular injections.

HAEMOPHILIA B (CHRISTMAS DISEASE)

Aberration of the factor IX gene, present on X chromosome, results in a reduction of factor IX level, giving rise to haemophilia B.



Treatment

Factor IX concentrate.

VON WILLEBRAND DISEASE

von Willebrand disease (vWD) is the most common hereditary bleeding disorder. It is characterised by a prolonged bleeding time (BT) and factor VIII-C levels between about 10-40%. Joint bleeding is rare.

The gene for von Willebrand factor (vWF) is located on chromosome 12 and is inherited as an autosomal disorder. Type I, IIA and IIB are autosomal dominant type. IIC and III are autosomal recessive.

Type I

It is characterised by a reduced quantity of circulating vWF. The synthesis of vWF is not impaired but the release of vWF multimers is inhibited by an unknown mechanism. This is the most common type of presentation.

Type II

This is less common. Here multimer assembly is defective and hence the large and intermediate multimers, representing the most active form of vWF are missing from plasma.



Clinical Features

Superficial bruising, epistaxis, menorrhagia and GI bleeding are common especially after trauma or surgery.

The diagnostic pattern consist of:

1. Prolonged bleeding time
2. Reduced plasma vWF concentrations
3. Reduction in biological activity as measured by ristocetin cofactor assay
4. Reduced factor VIII activity



Investigations

1. Reduced level of vWF
2. Secondary reduction in factor VIII
3. Prolongation of the bleeding time.



Management

1. Desmopressin increases vWF level and a secondary increase in factor VIII
2. Factor VIII-C concentrates (contain adequate vWF also)
3. *Cryoprecipitate*: It contains all of the vWF multimers. It is the safest and most cost-effective modality of treatment.
4. Platelet transfusions for cases with uncontrolled bleeding
5. Fresh frozen plasma (FFP) can be given for mild disease.



DISSEMINATED INTRAVASCULAR COAGULATION (DIC)

It is an acute, subacute, or chronic thrombohaemorrhagic disorder occurring as a secondary complication in a variety of diseases.

Diseases Associated with DIC

1. Infections (gram-negative sepsis, meningococemia, histoplasmosis, malaria, aspergillosis)
2. Neoplasms (carcinomas of pancreas, prostate, stomach and lung, acute leukaemias)
3. Obstetric complications (septic abortion, toxemia, abruptio placentae, retained dead foetus, amniotic fluid embolism)
4. Massive trauma, burns, or surgery
5. Others (snakebite, shock, heat stroke, liver disease).

DIC may present with

1. Signs and symptoms relating to infarction caused by microthrombi
2. A haemorrhagic diathesis due to consumption coagulopathy (consumption of platelet, factor V, VIII and fibrinogen).



Investigations

1. Platelet count shows thrombocytopenia
2. Prolongation of prothrombin time
3. PTT is also prolonged
4. Low fibrinogen level
5. Increased levels of D dimers in urine (fibrin degradation products are increased)
6. Peripheral film shows broken RBCs (schistocytes)
7. Clotting time is prolonged.



Management

1. Treat the underlying cause
2. Precipitating factors like acidosis, dehydration, renal failure and hypoxia should be corrected
3. Correction of platelet or factor VIII deficiencies
4. Prevention of sudden catastrophic haemorrhage (GI bleed or intracranial bleed)
5. Role of heparin is controversial.

Indications for Heparin

- a. When increases in platelet count or coagulation factors do not occur following replacement therapy and when the patient is continuing to bleed
- b. Fibrin deposition in the form of dermal necrosis as in purpura fulminans, acral ischaemia, or venous thromboembolism
- c. Retained dead foetus with hypofibrinogenaemia before induction of labour

- d. Excessive bleeding associated with a giant haemangioma
 - e. Before the induction of chemotherapy of acute promyelocytic leukaemia to prevent DIC
6. Monitor fluid balance and urine volume.
 7. Administration of FFP, cryoprecipitate, and platelets are needed.
 8. Recombinant activated protein C (drotrecogin) reduces mortality in patients with severe sepsis due to its anticoagulant and anti-inflammatory activity.

Bone Marrow Transplantation

Bone marrow transplantation is done if the patient's disease involves the marrow or if hazard to the normal marrow is the limiting factor in the aggressive treatment of a disease.

Bone marrow transplantation involves transplantation of erythroid, myeloid, lymphoid, megakaryocytic and macrophage monocyte system.

Indications

Oncological

Leukaemia

- Acute myeloid leukaemia
- Acute lymphoblastic leukaemia
- Chronic myeloid leukaemia

Others

- Multiple myeloma
- Lymphoma-Hodgkin's and non-Hodgkin's
- Breast cancer
- Neuroblastoma
- Ovarian cancer.

Nononcological

Haematological

- Aplastic anaemia
- Beta-thalassaemia major
- Myelodysplastic syndrome
- Paroxysmal nocturnal haemoglobinuria
- Bernard-Soulier syndrome
- Chediak-Higashi syndrome

Others

- Severe combined immunodeficiency
- Adenosine deaminase deficiency
- X-linked agammaglobulinaemia
- DiGeorge syndrome
- Wiskott-Aldrich syndrome
- Osteopetrosis
- Mucopolysaccharidosis.

Types of Bone Marrow Transplantation

1. *Syngeneic*: Donor and recipient are generally identical-identical twins.
2. *Allogeneic*: Donor and recipient are of different genetic origin, but of same species.
3. *Autologous*: Removal of patient's marrow, administration of chemo and/or radiotherapy to suppress the marrow and then reimplantation of the patient's own marrow.

Selection of the Donor

1. Donor must be in good health and should give consent.
2. HLA typing must be done.

Preparation of the Patient

1. Chemotherapy (large doses of cyclophosphamide in aplastic anaemia)
2. Chemoradiotherapy in leukaemia (cyclophosphamide + total body irradiation 10 Gy should be done)
3. Patients with genetic disease/leukaemia may be prepared with busulfan to destroy the abnormal marrow along with cyclophosphamide for immunosuppression.

Marrow Aspiration and Infusion

Aspirations are performed on iliac crests.

- For adult donors, volume of mixture of blood and marrow cells is from 0.5-1 litre. As each aspiration is performed, it is mixed with heparin and tissue culture medium.
- The marrow is passed through stainless steel screen to breakup the particles.
- It is given to the recipient intravenously. The marrow stem cells pass through the lungs. Subsequent growth and reconstitution of the marrow are confined to medullary cavities. It takes 2-4 weeks for the marrow to start functioning. By using G-CSF and GM-CSF, the period of granulocytopenia has been shortened to about 10 days.
- Platelet transfusion from HLA matched or unrelated donors may be necessary if the count becomes < 20,000/ μ L.
- Isolation facilities should be adequate and barrier nursing is provided.
- Granulocyte transfusion may be needed for refractory infections.
- Packed RBC transfusion may be given to control symptoms of anaemia. Hematocrit should be ideally kept > 25%.

- All blood products should be irradiated with 1.5 Gy to inactivate lymphocytes that might cause a graft versus host disease.
- Fever with clinical signs of bacteraemia or fever > 24 hours is an indication for systemic antibacterial therapy even if the cultures are negative.
- If fever continues to persist, addition of vancomycin and/or amphotericin should be considered. It should be continued until granulocyte count increases to > 500 cells/ μ L, even if clinical signs disappear.
- Hyperalimentation through Broviac catheter should be given.
- Engraftment is signalled by increase in granulocytes, and platelets and reappearance of reticulocytes. The regenerating marrow is of the donor type; sometimes there is persistence of a few host cells.

Complications Following Successful Engraftment

1. Rejection of the graft
2. Infections (bacterial, viral and opportunistic)
3. Acute and chronic graft versus host disease
4. Veno-occlusive liver disease
5. Recurrence of leukaemia.

Bone Marrow Transplantation (BMT) in Leukaemia

BMT from an identical twin or a HLA matched donor is an effective treatment for ALL and AML.

The objective is to administer high dose chemotherapy alone or with total body irradiation and then rescue the patient from myelosuppression by BMT from a normal donor. BMT of an allogeneic bone marrow may confer an immune mediated graft versus leukaemia effect.

Complications of Allogeneic Bone Marrow Transplantation

1. Graft versus host disease (GVHD)
2. Interstitial pneumonitis
3. Opportunistic infections
4. Relapse.

Autologous BMT

Remission bone marrow is collected and cryopreserved. Later, the patient receives intensive chemoradiotherapy followed by reinfusion of the cryopreserved bone marrow. The collected marrow is sometimes treated with anti-leukaemic monoclonal antibodies or chemotherapy.



It has an advantage of not requiring a matched donor and the absence of GVHD complications. The disadvantage is high rate of relapse.

Haematopoietic Stem Cell Transplantation

It involves IV infusion of either haematopoietic progenitors collected from the bone marrow by aspiration from the iliac crest or peripheral blood stem cells collected by apheresis after treatment of the donor with granulocyte colony-stimulating factor (G-CSF) or granulocyte-macrophage colony-stimulating factor (GM-CSF).

Allogeneic Stem Cell Transplant

The stem cells are collected from the donor. The donors are most commonly HLA matched siblings but can also be matched unrelated.

- To restore normal haematopoiesis or immune function in patients with aplastic anaemia, immunodeficiency or haemoglobinopathies.
- To treat resistant leukaemia and lymphoma.
- It is accompanied by GVHD- graft versus tumour effect plays an important role in curing leukaemia or lymphoma.

Autologous Stem Cell Transplant

The stem cells are collected from the patient. For autologous transplant, peripheral blood stem cells have largely replaced bone marrow as the source of progenitors because haematologic recovery is more rapid.

- The major advantage is that graft versus host disease (GVHD) does not occur.
- Transplant-related mortality is < 5%.
- Preferred mode of treatment for resistant lymphoma.
- Prolongs the survival of patients with multiple myeloma.
- Viable option for acute leukaemia patient in first remission who does not have compatible sibling donor.

Preparative Regimen

It is given immediately before transplant. It includes chemotherapy with or without total body irradiation.

- It provides immunosuppression that is needed for engraftment for patients with non-malignant conditions.
- It promotes engraftment and kills tumour cells for patients with resistant malignancy.



Complications

Complications of stem cell transplantation are as a result of high dose therapy (preparative regimen), pancytopenia (Neutrophil count <100 platelets <10,000), immunodeficiency, or GVHD. In autologous transplant, immune function recovers within 3-6 months whereas in allogeneic transplant immune function recovery is further delayed due to GVHD.

Infections

- Febrile patients after transplant should be cultured and immediately be placed on IV broad-spectrum antibiotics.
- Seropositive herpes simplex patients should receive acyclovir prophylaxis until neutrophil recovery.
- Give G-CSF or GM-CSF until neutrophil recovery.
- For allogeneic transplant patients, long-term prophylaxis for varicella-zoster virus with acyclovir and for pneumocystis with trimethoprim/sulfamethoxazole.
- Periodic shell vial culture or PCR assays biweekly (for 6 months) for CMV and if the test is positive, give ganciclovir or foscarnet.

Graft Versus Host Disease (GVHD)

- It is the major complication of allogeneic transplantation and the mortality is 20-30%.
- Acute GVHD is the one that occurs within the first 100 days of transplant and it occurs in 30-50% of transplants despite prophylaxis with cyclosporine and methotrexate. Skin rash, diarrhoea and liver dysfunction are common manifestations.
- Chronic GVHD manifests after 100 days of transplant. It resembles an autoimmune disorder. Keratoconjunctivitis sicca, lichenoid changes of buccal mucosa, and sclerodermatous skin changes are some of the manifestations.
- Graft versus tumour effect is unique to allogeneic transplant and plays a key role in eradicating residual malignancy (donor 'T' cells mediate immunological destruction of residual tumour cells).

Veno-Occlusive Disease (VOD)

- It occurs within 3 weeks in 1-5% of patients.
- Clinical manifestations – Tender hepatomegaly, jaundice, fluid retention and ascites.
- VOD is usually fatal in severe forms.

Pulmonary Complications

- CMV pneumonia—It occurs in allogeneic transplants when either the patient or the donor is seropositive for CMV. It occurs within 6 months of transplant and it can be treated with gancyclovir or foscarnet.
- Interstitial pneumonitis—It occurs within 3 months of transplant and this is a complication of total body radiation or high dose chemotherapy. Prednisone is the drug of choice.

Peripheral Blood Stem Cell Transplantation (PBSCT)

Autologous PBSCT has now replaced autologous BMT in several centres.

Procedure

This has been possible only with the help of haematopoietic growth factors which are necessary for

mobilisation of haematopoietic precursors as well as for accelerated engraftment, post-transplant. Usually G, GM-CSF is first administered SC for mobilisation of precursor cells into the peripheral blood. CSFs are preferred because they do not damage DNA besides giving predictable and consistent results. PBSCs are then collected during 3-6 outpatient leukapheresis using blood cell separators such as Hemonetics MCS 3P, Cobe Spectra or Fenwall CS-3000. About 6 to 8 litres of blood are processed daily to yield a stem cell concentrate of about 150 ml. The product is then cryopreserved in liquid nitrogen or at minus 80°C. Once enough cells have been harvested, the patient is subjected to potentially curative high dose chemoradiotherapy. After a 48 hours washout period, the cryopreserved stem cells are thawed and immediately reinfused into the patients. Growth factors can be continued post-infusion to further hasten engraftment and also to reduce mucositis. Both G and GM-CSF can accelerate recovery.

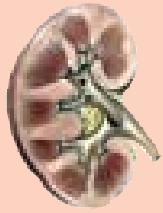

Chapter 7

Nephrology

SYMPTOMS

SIGNS

PAIN

HAEMATURIA

OLIGURIA

ANURIA

POLYURIA

NOCTURIA

DYSURIA

PNEUMATURIA

HESITANCY

PRECIPITANCY

INCONTINENCE

URETHRAL
DISCHARGE

SWELLING OF LEGS

BREATHLESSNESS

Puffiness of face

Constitutional symptoms

Conscious level

Anaemia

Polycythaemia

Scratch marks

Acidotic breathing

Pedal oedema

Hypertension

Pulmonary oedema

Lung crackles

Pericardial rub

Enlarged/contracted
kidneys, Loin tenderness

Flapping tremor

Signs of peripheral neuropathy

Retinopathy
(Diabetic/hypertensive)

Muscle weakness

Bony tenderness

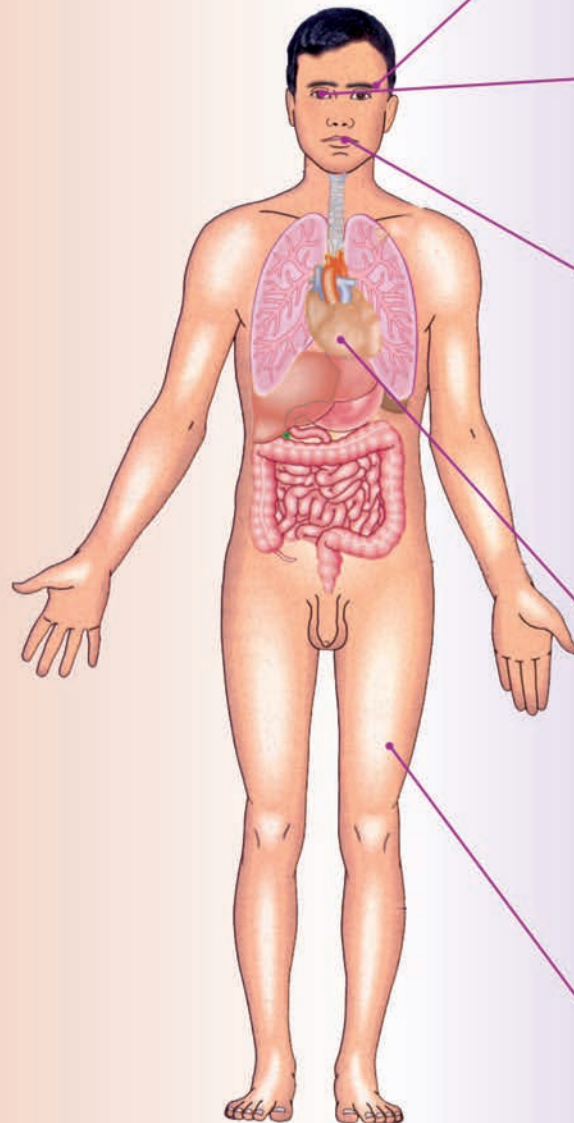

Urine Analysis

Examination of the urine is one of the most rewarding steps in clinical medicine. It uncovers renal parenchymal and urinary tract disease.

Methods of Collection of Urine Specimens

Urine should be examined promptly for accurate results.

Midstream Urine Collection

In collecting urine for microscopic examination, it is important to avoid contamination with bacteria, squamous cells, and leukocytes. In both sexes at least 200 ml should be passed before collecting a midstream urine specimen without interrupting the flow of urine. The important points in collecting a good midstream urine sample are as follows:

In women:

- Where possible use a vaginal tampon.
- Hold labia well-separated during collection of the specimen.
- Gently cleanse the periurethral area with several moistened gauze pieces from anterior to posterior.

In men:

- The retracted foreskin is held back throughout the collection.
- The urethral meatus is cleansed with moist gauze.

Although bacteria are often detected on microscopy, infection is best proved by culture, which will also allow testing of antibiotic sensitivity of infecting organism. Culture results are reported as colony forming units (CFU) per ml of urine; the significance of a count depends on the method of collection.

A Catheter Specimen

At least 200 ml must pass through the catheter to flush out contaminating urethral contents before the specimen is collected.

Suprapubic Aspiration

A fine lumbar puncture needle with stylet in place is passed through sterilized suprapubic skin directly into a full bladder. Uncontaminated urine can then be aspirated.

Dipstick Testing

Dipstick testing of urine provides a rapid determination of urine pH, specific gravity, and the presence of protein, blood, glucose, and bile. Dipsticks are less sensitive in detecting pyuria and bacteriuria.

Dipstick testing detects only albumin at concentration more than 250 mg/L. Separate sticks are available for microalbuminuria.

False-positive dipstick results for proteinuria are seen when urine pH is > 8, and when the patient is on penicillins, aspirin or oral hypoglycemic agents.

False-negative tests for detection of haemoglobin occurs with ingestion of ascorbic acid.

Microscopic Analysis

Second voided urine of morning is used as formed elements are not altered.

Urine is characteristically examined by utilizing a standard light microscope to make a semiquantitative estimate of the frequency of the formed elements in the urine by counting their number per high-power field.

The accuracy of the microscopic examination can be enhanced by using phase-contrast microscopy, which allows for better morphologic detail of urinary sediments.

Haematuria

When a large amount of blood is present in the urine, this is obvious to the naked eye. The red blood cell count in such cases is always well above 10^6 per ml (10 lakhs/ml).

The morphology and quantitation of the urinary erythrocytes are two of the most important investigations in clinical nephrology.

Influence of Collection Technique on Accuracy of Detection of Urine Abnormalities

Collection technique	Haematuria	Pyuria	Significant bacteriuria (CFU/ml)	*Fastidious micro-organism
Midstream urine	Excellent	Fair	> 1,00,000 (10^5)	Poor
Catheter specimen	Good	Very good	> 1,000 (10^3)	Good
Suprapubic aspiration	Poor	Excellent	> 1	Excellent

*Fastidious micro-organism grow best when there is least contamination with other commensal micro-organisms. This contamination is maximum in a collection of midstream urine sample and least with suprapubic aspiration.



Glomerular haematuria: It should be suspected in the presence of

- a. Dysmorphic urinary erythrocytes
- b. Erythrocytes with MCV < 72 fl
- c. Presence of RBC casts
- d. Concomitant proteinuria (> 1 gm/day)

Nonglomerular haematuria: It is characterised by the presence of

- a. Isomorphic urinary erythrocytes
- b. Erythrocytes with MCV > 72 fl
- c. Absence of RBC casts
- d. No significant proteinuria.

The best method of assessing erythrocyte morphology is by phase-contrast microscopy.

Causes of haematuria: Normally ≤ 3 RBC/mm³ may be seen in an uncentrifuged urine sample or upto 1 RBC/HPF in a centrifuged urine sample. RBCs present in excess of the above number indicates haematuria.

1. **Renal**
 - a. Glomerular disease
 - b. Carcinoma (renal cell, transitional)
 - c. Cystic disease (polycystic disease, medullary sponge kidney)
 - d. Trauma
 - e. Vascular malformation
 - f. Emboli.
2. **Extra-renal**
 - a. Calculi
 - b. Infection
 - c. Neoplasm
 - d. Prostatitis
 - e. Trauma
 - f. Urethritis
 - g. Bladder-catheterization
 - h. Post-cyclophosphamide.
3. **Systemic**
 - a. Coagulation disorders (including anticoagulant drugs)
 - b. Sickle cell trait or disease
 - c. Vasculitis.

Urine may be coloured red in the presence of haemoglobin, myoglobin, drugs (e.g. rifampicin), beetroot ingestion and porphyria. RBCs are absent in urine.

Intermittent haematuria

- IgA nephropathy
- Alport syndrome
- Tumour
- ADPKD

Urine darkens on standing in

- Porphyria
- Melanoma
- Alkaptonuria.

Urinary Casts (Fig. 7.1)

Casts are formed from Tamm-Horsfall glycoprotein, which is synthesized and secreted in the ascending limb of the loop of Henle. The Tamm-Horsfall protein along with cellular elements forms the cast in acid medium.

1. **Physiologic casts**
 - a. **Hyaline casts** are transparent and cylindrical, and are seen in the urine of normal subjects.
 - b. **Granular casts** are semitransparent cylinders with refractile granules of uncertain origin.
2. **Pathological casts:** Casts may contain cellular material (erythrocytes, leukocytes, tubular cells, bacteria or fungi), fibrin, lipids, bile and/or crystals.
 - a. **RBC casts** are the most important indicator of glomerular bleeding (glomerulonephritis).
 - b. **WBC casts** composed of polymorphonuclear leukocytes usually indicate renal parenchymal infection (pyelonephritis).
 - c. Fat is a common component of casts in nephrotic syndrome.
 - d. **Crystals in casts** are commonly present in patients who are taking triamterene, with hypercalcaemia or hyperuricosuria.
 - e. **Broad waxy casts** signify chronic renal disease.

Leucocytes in Urine

An increase in the leukocyte count in the urine most commonly implies infection.

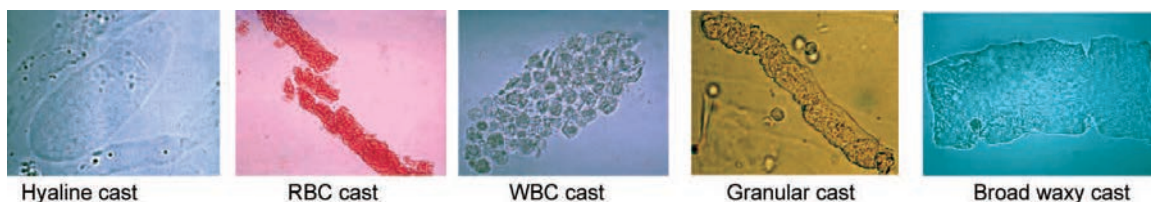

Fig. 7.1: Urinary casts

If number of WBCs in uncentrifuged midstream urine in women is

> 10/mm³, it is abnormal.

3–10/mm³, it is of doubtful significance.

If number of WBCs in uncentrifuged midstream urine in men is > 3/mm³, it is abnormal. If the number of WBCs in centrifuged midstream urine in both men and women is > 5 WBCs/HPF, it is abnormal.

When pyuria is present without bacteria (sterile pyuria), three-fourth of the patients show an underlying urinary abnormality.

Noninfective causes of WBCs in urine

Nephrocalcinosis

Papillary necrosis

Analgesic nephropathy.

Renal Tubular Cells

Large number of renal tubular cells are found in the urine in acute tubular necrosis and acute interstitial nephritis. However, in acute interstitial nephritis, there is a higher count of leukocytes. Eosinophils are present in urine above 5000 per ml.

These findings are rare in acute tubular necrosis.

Crystals

Large bizarre crystals of any type including calcium oxalate and uric acid usually indicate increased urinary excretion and may indicate calculus disease.

Cystine crystals are always abnormal and indicate cystinuria (Fig. 7.2).

Proteinuria

Urine protein composition (total 150 mg/day in adults)

Tamm-Horsfall protein	70 mg
Blood group related antigen	35 mg
Albumin	15 mg
Mucopolysaccharide	15 mg
Immunoglobulins	5 mg
Rest hormones and enzymes	10 mg

An abnormal amount of protein excreted in the urine is a cardinal manifestation of disease in virtually all patients with glomerulonephritis.

Fever, exercise, hyperglycaemia, and severe hypertension can transiently cause proteinuria.

To precisely quantitate and qualitatively analyze the amount and composition of urinary proteins, an examination of a 24-hour collection of urine is usually required. Quantification of the 24-hour urine creatinine should be performed concomitantly to ensure that a complete collection was submitted.

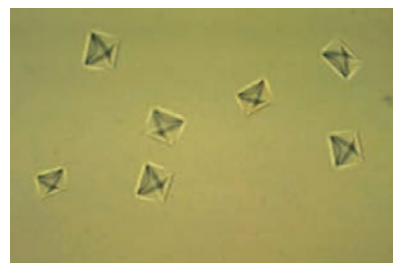

Oxalate crystals

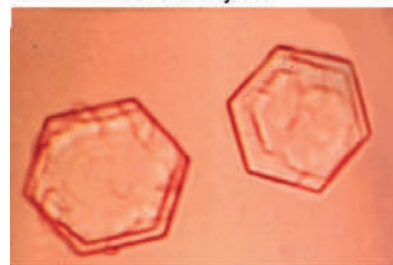

Cystine crystals

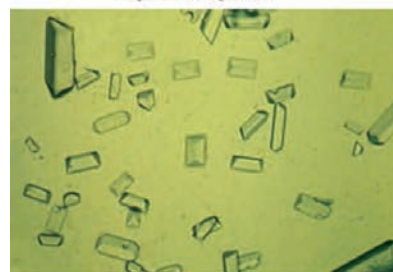

Triple phosphate crystals

Fig. 7.2: Crystals in urine

A urinary protein creatinine concentration ratio on the first voided morning urine sample is useful substitute for repeated 24-hour urine protein estimation.

The normal 24-hour urine protein excreted in the adult ranges from 30 to 130 mg. Children and adolescents may excrete as much as twice this amount.

Normal spot urinary protein creatinine ratios on random samples generally fall below 2. Values > 3 suggest the presence of nephrotic range proteinuria.

Normally urine proteins are comprised of filtered proteins from plasma (50%) and proteins that are secreted into the urine from urinary tract cells (50%).

Of the filtered proteins, albumin is the most abundant.

Of the secreted proteins, Tamm-Horsfall protein is the most abundant.

Urine protein electrophoresis (UPEP) and immunoelectrophoresis (IEP) can be helpful in identifying the nature of proteins present in the urine.



Pathophysiologic Classification of Proteinuria

1. Overflow proteinuria
2. Tubular proteinuria
3. Glomerular proteinuria
4. Other types of proteinuria.

1. OVERFLOW PROTEINURIA

It is due to the filtration by the normal glomerulus of an abnormally large amount of small molecular-weight protein present in serum whose filtration exceeds the capacity of normal tubules for reabsorption. This occurs in monoclonal gammopathies (such as multiple myeloma), in intravascular haemolysis (haemoglobinuria), and in rhabdomyolysis (myoglobinuria).

2. TUBULAR PROTEINURIA

It is found in both acute and chronic injuries involving the renal tubulointerstitial region. It is derived from three sources:

- a. Injured tubules fail to completely reabsorb small molecular weight proteins filtered by the glomerulus.
- b. Injured tubules secrete into the urine brush border, components and cellular enzymes, such as N-acetylglucosamine and lysozyme.
- c. With tubulointerstitial injury, Tamm-Horsfall protein may be secreted into the urine in greater amounts.

Causes of Tubular Proteinuria

1. Hereditary
 - a. Polycystic kidney disease
 - b. Medullary cystic disease
2. Infections
 - a. Pyelonephritis
 - b. Tuberculosis
3. Metabolic
 - a. Diabetes mellitus
 - b. Hyperuricaemia
 - c. Uricosuria
 - d. Hypercalcaemia
 - e. Hypercalciuria
 - f. Hypokalaemia
 - g. Oxalosis
 - h. Cystinosis
4. Immunologic
 - a. Sjögren's syndrome
 - b. Renal transplant rejection
 - c. Drug hypersensitivity
 - d. Sarcoidosis

5. Toxic
 - a. Analgesic abuse
 - b. Radiation nephritis
 - c. Lithium
 - d. Heavy metals
 - e. Cyclosporine
 - f. Cisplatin
 - g. Aminoglycosides
6. Anatomic
 - a. Obstruction
 - b. Reflux-severe vesicoureteric
 - c. Medullary sponge kidney
7. Miscellaneous
 - a. Multiple myeloma
 - b. Amyloidosis
 - c. Sickle cell disease.

3. GLOMERULAR PROTEINURIA

It occurs when injury to the glomerulus results. Glomerular proteinuria is comprised predominantly of albumin and, when quantitatively large (e.g. > 3.0–3.5 gm/day) is said to be in the nephrotic range.

Causes of Glomerular Proteinuria

1. Primary glomerular disorders
 - a. Minimal change
 - b. Mesangial proliferative
 - c. Focal and segmental glomerulosclerosis
 - d. Membranous
 - e. Membranoproliferative
 - f. Crescentic
2. Hereditary
 - a. Alport's syndrome
 - b. Fabry's disease
3. Infections
 - a. Bacterial endocarditis
 - b. Poststreptococcal glomerulonephritis
 - c. Secondary syphilis
 - d. Hepatitis B and C
 - e. HIV
 - f. Malaria
4. Metabolic—Diabetes mellitus
5. Immunologic
 - a. SLE
 - b. Sjögren's syndrome
 - c. Henoch-Schönlein purpura
 - d. Wegener's granulomatosis
 - e. Goodpasture's syndrome
6. Drugs
 - a. Penicillamine
 - b. Gold or mercury containing compounds



- c. Lithium
 - d. NSAIDs
 - e. ACE inhibitors
 - f. Heroin
7. Neoplasms
- a. Multiple myeloma
 - b. Colon, lung or breast carcinoma
 - c. Lymphoma
 - d. Leukaemia
8. Miscellaneous
- a. Sickle cell anaemia
 - b. Allergies
 - c. Immunizations
 - d. Cirrhosis
 - e. Amyloidosis
 - f. Reflux nephropathy.

4. OTHER TYPES OF PROTEINURIA

- a. *Benign orthostatic proteinuria* is typically found in tall adolescents.

Protein is found in the urine collected on retiring and in the morning after the patient has been ambulant, but not in the overnight specimen collected immediately on rising. There should be no abnormality in the urine sediment, and proteinuria should not exceed 1 gm per day. In half the patients, proteinuria disappears within 10 years, however, in a small proportion overt renal disease will develop in later life.

- b. *Transient proteinuria* may be associated with conditions like cardiac failure, fever, or heavy exercise. It disappears within hours after cessation of exercise and with resolution of the disease process. Proteinuria after marathon running may be as heavy as 5 gm per litre of urine.

Selective proteinuria is said to occur when the ratio of clearance of IgG (1.6 lakh kd) to transferrin (88,000 kd) is less than 0.1. Minimal change disease in children produces selective proteinuria. Because of lower molecular weight there is selective excretion of albumin in urine.

Difference between Tubular and Glomerular Proteinuria

<i>Tubular proteinuria</i>	<i>Glomerular proteinuria</i>
1. Occurs in injury involving the tubulointerstitial region of kidney	Occurs due to injury of the renal glomerulus
2. Comprises of <ul style="list-style-type: none"> a. Low molecular weight proteins (β_2 microglobulin) filtered by the glomerulus and not reabsorbed by the tubules b. Cellular enzymes secreted by renal tubules c. Increased amount of Tamm-Horsfall protein 	Comprises predominantly of albumin (low molecular weight protein)
3. Quantitative excretion of protein is usually < 2 gm/day	Quantitative excretion of protein may be large (> 3–3.5 gm/day)
4. Urinary protein electrophoretic pattern (UPEP) shows more globulin than albumin.	UPEP shows more albumin than globulin
5. Albumin: β_2 microglobulin ratio is 100 : 1 (normal ratio is 50–200 : 1)	Ratio > 1000 : 1

Microalbuminuria

This indicates an excretion of albumin of 20–200 microgram per minute (albumin excretion rate or AER), or a daily excretion of albumin in the range of 30–300 mg.



Causes

- a. Diabetes mellitus with early renal involvement
- b. Hypertension
- c. Myocardial infarction
- d. Acute phase response
- e. Obesity
- f. Hyperlipidemia
- g. Alcohol intake
- h. Physical exercise.

Methods of Screening Microalbuminuria

<i>Method</i>	<i>24-hour urine specimen</i>	<i>First morning urine specimen</i>	<i>Microalbumin to creatinine ratio in random/first morning urine specimen</i>
Normal range	< 30 mg/24 hours	< 20 mg/L	< 30 mg/g for women < 20 mg/g for men
Microalbuminuria	30–300 mg/24 hours	20 – 200 mg/L	30-300 mg/g for women 20-200 mg/g for men
Macroalbuminuria	> 300 mg/24 hours	> 200 mg/L	> 300 mg/g for women > 200 mg/g for men



Reducing Substances in Urine

1. Diabetes mellitus (glycosuria)
2. Renal glycosuria (defective tubular reabsorption of glucose)
3. Pregnancy (lactosuria)
4. Ingestion of fruits like grapes, plums, cherries (pentosuria)
5. Inborn error of metabolism (galactosuria, fructosuria)
6. Alkaptonuria (homogentisic acid)
7. Drugs (ascorbic acid, aspirin, cephalosporins, nalidixic acid).

24 hour Urine Studies

- Urine volume
- Quantum of creatinine excreted and to calculate GFR

The GFR can be estimated by calculation of the Cl_{Cr} :

$$Cl_{Cr} \text{ (mL/min)} = \frac{\text{(Urine Cr [mg/dL]} \times \text{Volume [mL]})}{\text{(Serum Cr [mg/dL]} \times \text{Time [min]})}$$

Creatinine clearance value is useful:

1. For adjusting the drug dosage
 2. To predict the remaining renal function
 3. To time and plan the placement of dialysis
- Quantum of protein excreted
For confirming the diagnosis of nephrotic syndrome and to assess the response to management of certain glomerular disorders

Blood Tests for Evaluating Glomerular Disorders

ESR, antinuclear, anti-GBM, and antineutrophil cytoplasmic antibodies, antistreptococcal antibody titers, complement levels, cryoglobulin studies and serology for hepatitis B, C, and HIV are helpful in evaluation.

Serum and Urine Protein Electrophoresis

To diagnose multiple myeloma and amyloidosis

Urine Eosinophils

Seen in interstitial nephritis, RPGN, acute prostatitis, and renal atheroemboli.

Renal Ultrasonography

- To assess kidney size
 - To detect hydronephrosis
 - To identify polycystic kidney disease
- Small kidneys < 10 cm generally reflect chronic renal disease and size < 8 cm denotes contracted kidney (ESRD). A discrepancy in kidney size of > 2 cm may suggest unilateral renal artery stenosis.

IV Urography

It should be performed only in patients with normal renal function for evaluation of stone disorders and nonglomerular haematuria.

Radionuclide Scanning

Technetium isotopes are used in scanning to assess renal function, leaks and rejection in transplanted kidneys.

MRI Imaging and Angiography

The advantage is in avoiding the usage of nephrotoxic contrast agent. It is useful to assess renal mass lesion, renal artery stenosis and renal vein thrombosis.

Creatinine Clearance (Cl_{Cr})

If the serum creatinine is stable, the glomerular filtration rate (GFR) can be estimated by using the Cockcroft-Gault formula for creatinine clearance.

$$Cl_{Cr} \text{ (ml/min)} = 140 - \text{age} \times \text{Ideal body weight in Kg} / 72 \times \text{serum Cr (mg/dl)} \\ (\times 0.85 \text{ for women})$$

Urinary Tract Infection

Definitions

Upper urinary tract infection: Infection involving the kidney.

Lower urinary tract infection: Infection involving the bladder, prostate, and urethra.

Bacteriuria: It is the presence of bacteria in urine. Its presence places the entire urinary system at risk of invasion by bacteria.

Significant bacteriuria: It is defined as the presence of 1,00,000 (10^5) or more colony forming units (CFU) of bacteria per millilitre of midstream urine.

Pyelonephritis: It is a specific or nonspecific inflammation of the renal parenchyma.

Acute bacterial pyelonephritis: It is a clinical syndrome characterized by chills and fever, flank pain, and constitutional symptoms caused by bacterial invasion of the kidney.

Chronic pyelonephritis: It is a renal disease that is caused by a variety of disorders such as chronic obstructive uropathy, vesicoureteral reflux (VUR) (reflux nephropathy), renal medullary disease, drugs and toxins, and chronic or recurring renal bacteriuria.

Cystitis: It is infection confined to the urinary bladder.



Urethritis: It is infection confined to the urethra.

Prostatitis: It is infection confined to the prostate.

Relapse of infection: Relapse is a recurring infection due to the same micro-organism that is often drug resistant. Most relapses occur after treatment of acute pyelonephritis or prostatitis.

Reinfection: It is a recurring infection due to a different micro-organism that is usually drug susceptible. Most recurring episodes of cystourethritis are due to reinfection.

Asymptomatic bacteriuria: It is the presence of bacteriuria, indicating urinary tract infection, in the absence of symptoms. It occurs commonly in pregnant women.

Uncomplicated urinary infection: It is an episode of cystourethritis following bacterial colonization of the urethral and bladder mucosa. This type of infection is considered uncomplicated because sequelae are rare.

Complicated urinary infection: These are infections involving parenchyma (pyelonephritis or prostatitis) and frequently occur in the presence of obstructive uropathy or following instrumentation. Episodes may be refractory to therapy, often resulting in relapses and occasionally leading to significant sequelae such as sepsis, metastatic abscesses and rarely, acute renal failure.

Risk Factors Associated with Urinary Tract Infection

1. Obstruction to urine flow
 - a. Congenital anomalies
 - b. Renal calculi
 - c. Ureteral occlusion (partial or total)
2. Vesicoureteral reflux
3. Residual urine in bladder
 - a. Neurogenic bladder
 - b. Urethral stricture
 - c. Prostatic hypertrophy
4. Instrumentation of urinary tract
 - a. Indwelling urinary catheter
 - b. Catheterization
 - c. Urethral dilation
 - d. Cystoscopy
5. Sex—Women
 - a. Honeymoon cystitis
 - b. Pyelitis of pregnancy
 - c. Use of diaphragm or spermicide.

Pathogenesis

Bacteria in the enteric flora periodically gain access to the genitourinary tract. Close proximity of the anus to

the genitourinary tract in women is a likely factor. Subsequent bacterial colonization of uroepithelial cells sets the stage for persistent bacteriuria.

Opposing colonizations are several host factors, like acid pH, normal vaginal flora, type-specific cervico-vaginal antibodies and flushing effect of urine during micturition.

Following periurethral colonization, uropathogens gain access to the bladder via the urethra, to the kidneys via the ureters, and to the prostate via the ejaculatory ducts. The urethra and ureterovesical junction are mechanical barriers that prevent ascension.

Urine adequately supports the growth of most uropathogens. However, the urinary bladder has several protective mechanisms to prevent its colonization and growth.

1. Mucopolysaccharide (urine slime) layer covers the bladder epithelium and prevents colonization.
2. Tamm-Horsfall protein, adheres to *P fimbriae* of the micro-organism and prevents colonization.
3. Urine flow and bladder contraction serve to prevent stasis and colonization.

Symptoms of UTI

1. Frequency
2. Dysuria
3. Haematuria
4. Incontinence
5. Retention of urine
6. Fever with chills and rigors
7. Urgency
8. Strangury
9. Pain over loin or suprapubic region.



Investigations

1. Urine specimens for culture, sensitivity and colony forming unit counts.

Common microbial pathogens causing UTI

<i>Escherichia coli</i>	50–90%
<i>Klebsiella</i> or <i>Enterobacter</i>	10–40%
<i>Proteus</i> , <i>Morganella</i> or <i>Providencia</i>	5–10%
<i>Pseudomonas aeruginosa</i>	2–10%
<i>Staphylococcus saprophyticus</i>	2–10%
<i>Enterococcus</i>	2–10%
<i>Candida albicans</i>	1–2%
<i>Staphylococcus aureus</i>	1–2%

2. Localisation of infection with segmented cultures of the lower urinary tract in men.

Positive culture obtained from the first 10 ml of voided urine indicates urethral infection.



Positive culture from midstream sample of urine indicates bladder infection.

Positive culture obtained from the first 10 ml of voided urine obtained after a prostatic massage, indicates prostatic infection. This is done by asking the patient to assume the knee-elbow position, with a full bladder. A prostatic massage is then performed per rectally. The patient is then asked to void urine, which is cultured.

3. *Microscopic examination of urine for Gram's stain and sediments.*

Causes for sterile pyuria

1. Inadequately treated UTI
 2. Infection (TB, atypical streptococci, corynebacteria, fastidious micro-organisms)
Fastidious micro-organisms like Chlamydia, ureaplasma urealyticum
 3. Calculi
 4. Bladder tumour
 5. Chemical cystitis
 6. Prostatitis
 7. Papillary necrosis
 8. Interstitial nephritis
 9. Polycystic kidneys
 10. Appendicitis.
4. *Biochemical tests for bacteriuria:* Two metabolic capabilities shared by most bacterial pathogens of the urinary tract are, use of glucose and reduction of nitrate to nitrite. Significant number of bacteria in urine results in absence of glucose and presence of nitrite detected by dipstick devices.
5. *Radiography:* The principal role of radiographic and urologic studies in patients with UTIs is to detect VUR (vesicoureteric reflux), renal calculi, and potentially correctable lesions that obstruct urine flow and cause stasis.

Infants, boys, and men with first episode and girls and women with relapsing UTIs should have an intravenous pyelogram (IVP) with postvoiding radiographs. For a detailed evaluation of the ureterovesical junction, bladder, and urethra, a voiding cystourethrogram and measurement of the residual urine after voiding may be necessary.

Principles of Treatment of UTI

1. Asymptomatic patients should have colony counts greater than or equal to 10^5 per millilitre on at least two occasions before treatment is considered.
2. Unless symptoms are present, no attempt should be made to eradicate bacteriuria until catheters, stones, or obstructions are removed.

3. Selected patients with chronic bacteriuria may benefit from suppressive therapy.
4. A patient who develops bacteriuria as a result of catheterisation should have treatment to re-establish a sterile urine.
5. Antimicrobials used for treatment should be the safest and least expensive agents to which the causative micro-organisms are susceptible.
6. Efficacy of treatment should be evaluated by urine culture one week after completion of therapy.
Relief of clinical symptoms does not always indicate bacteriological cure.
7. Each course of treatment should be certified after its completion as cure (elimination of symptoms and subsequent culture negativity) or failure (persisting symptoms, bacteriuria or positive culture after therapy).

Recommendations for Use and Care of Urinary Catheters

Urinary catheters are valuable devices for enabling drainage of the bladder, but their use is associated with an appreciable risk of infection in the urinary tract. This occurs as the micro-organisms can "climb up" along the outer surface of the catheter, using it as a "ladder". The ascent is uninhibited as flow of urine occurs within the catheter only.

The following recommendations for the prevention of catheter associated UTIs may be followed:

- a. Indwelling urinary catheters should be used only when absolutely necessary.
- b. Catheters should be inserted only by adequately trained personnel.
- c. Urinary catheters should be aseptically inserted using proper sterile techniques.
- d. Once or twice daily perineal care for catheterised patients should be done.
- e. A sterile closed drainage system should always be used.
- f. Nonobstructed gravity flow must be maintained at all times.
- g. In patients with chronic indwelling catheters, replacement is necessary when concretions can be palpated in catheter or when malfunction or obstruction occurs.



Management of UTI

1. *Treatment of uncomplicated UTI* is with a course of any one of the following antibiotics taken orally for a period of 3 days.



- i. Trimethoprim-sulfamethoxazole (2 tablets of 80 mg/400 mg each) every 12 hours.
- ii. Ampicillin 500 mg every 6 hours.
- iii. Amoxicillin 500 mg every 8 hours.
- iv. Tetracycline 250–500 mg every 6 hours.
- v. Cephalexin 250–500 mg every 6 hours.
- vi. Ciprofloxacin 250–500 mg every 12 hours.
- vii. Norfloxacin 400 mg every 12 hours.

A single dose therapy can also be tried in uncomplicated UTI with any one of the following drugs.

- i. Ampicillin 3 gm
 - ii. Amoxicillin 3 gm
 - iii. 80 mg of trimethoprim/400 mg sulphamethoxazole 4 tablets.
2. *Treatment of prostatic infection* is with a prolonged dose of specific antibiotics which can penetrate the prostate. The duration of treatment in acute prostatitis is 10–14 days, whereas the duration of treatment of chronic prostatitis is 1–3 months. The drugs used are:
- i. 160 mg trimethoprim/800 mg sulphamethoxazole twice daily
 - ii. Ciprofloxacin 500 mg twice daily
 - iii. Norfloxacin 400 mg twice daily.
3. *Treatment of complicated UTI* is with a course of any one of the following antibiotics given parenterally for a period of 10–14 days.
- i. Gentamicin 1.5–2 mg/kg/day every 8 hours.
 - ii. Tobramycin 1.5–2 mg/kg/day every 8 hours.
 - iii. Ampicillin 1 gm every 4 hours.
 - iv. Ciprofloxacin 200 mg every 12 hours.
4. *Asymptomatic bacteriuria*: The following special situations warrant drug therapy irrespective of colony count.
- i. Pregnancy
 - ii. Renal transplant patients
 - iii. Neutropenic patients
 - iv. Obstructive uropathy.

In both instances, a urine culture is obtained 1 week after stopping the antibiotic in order to determine the efficacy of treatment.

Prophylaxis for UTI

UTI prophylaxis is indicated in the following conditions:

1. Chronic prostatitis
2. Pregnant women with asymptomatic bacteriuria
3. Prostatectomy—Intra and postoperative
4. Frequent UTI in women (>3/year)
5. Vesiculo-ureteral reflux.

Glomerulopathies

Glomerular diseases may be primary or secondary to systemic disorders. It may present with isolated haematuria, or proteinuria. The presentation may be in the form of nephritic or nephrotic syndrome. Renal biopsy often provides useful diagnostic, therapeutic, and prognostic information.

Classification

Primary glomerulopathies

- A. Minimal change disease
- B. Focal segmental glomerulosclerosis
- C. Membranous nephropathy
- D. IgA nephropathy

Secondary glomerulopathies

- A. Diabetic nephropathy
- B. SLE
- C. Membrano-proliferative nephropathy
- D. Dysproteinemias
- E. Infection related glomerulopathies
 - i. Bacterial endocarditis
 - ii. Visceral abscess
 - iii. Infected shunts
 - iv. Post streptococcal glomerulonephritis
- F. Pulmonary renal syndromes
 - i. Goodpasture's syndrome
 - ii. Wegener's granulomatosis
 - iii. Microscopic polyangiitis
- G. Sickle cell nephropathy
- H. HIV associated nephropathy.

Classification of Nephritic Syndrome Based on Complement Levels

- I. Low complement level (C_3) (Immune complex glomerulonephritis)
 1. Post-infectious glomerulonephritis
 2. Bacterial endocarditis
 3. SLE
 4. Cryoglobulinaemia
 5. Crescentic glomerulonephritis
 6. Membranoproliferative glomerulonephritis
- II. Normal complement level
 - Immune complex mediated
 1. IgA nephropathy
 2. Henoch-Schonlein purpura
 3. Fibrillary glomerulonephritis
 - Anti-GBM disease
 1. Goodpasture's syndrome



- Pauci immune glomerulonephritis
 1. Wegener's granulomatosis
 2. Microscopic polyarteritis nodosa

HIV Associated Nephropathy

- Occurs after an interval of 2.5 years after the diagnosis of HIV
- Many patients have low CD₄ counts
- Renal biopsy reveals FSGS followed by MPGN
- FSGS reveals collapse of the glomerular capillary tuft called as "collapsing glomerulopathy"
- They have nephritic range of proteinuria and hypoalbuminaemia
- Hypertension, hyperlipidaemia and oedema are uncommon
- ACE inhibitor and antiretroviral therapy

Nephrotic Syndrome

This is characterised by albuminuria ($> 3.5 \text{ gm}/1.73 \text{ m}^2/\text{day}$) and hypoalbuminaemia ($< 3 \text{ gm}/100 \text{ ml}$) and accompanied by oedema, hyperlipidaemia (cholesterol $> 300 \text{ mg}/\text{dl}$), and lipiduria.

Causes of Nephrotic Syndrome

Systemic causes (25%)	Glomerular disease (75%)
Diabetes mellitus, SLE, amyloidosis	Minimal change disease (90% in children and 15% in adults)
Drugs: Gold, penicillamine, probenecid, street heroin, captopril, NSAIDs	Membranous (40% in adults)
Infections: Bacterial endocarditis, hepatitis B, shunt infections, syphilis, malaria	Focal glomerulosclerosis
Malignancy: Hodgkin's and other lymphomas, leukaemia, carcinoma of breast and GI tract	Membranoproliferative GN
Allergic reactions	Mesangioproliferative GN



Clinical Features

Patient usually presents with insidious onset of generalised oedema, without a decrease in urine output. Patient may complain of passing frothy urine due to presence of protein.

Minimal Change Disease

This occurs commonly in children below 16 years of age, accounting for about 70–80% of nephrotic syndrome in them.

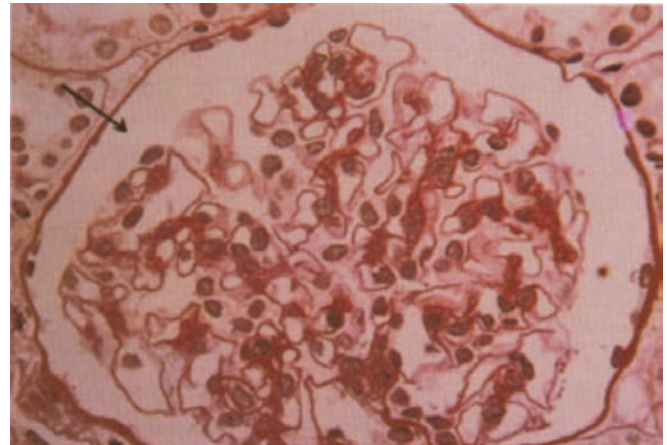

Fig. 7.3: Normal glomerulus—Bowman's space is clearly illustrated

The blood pressure is normal. GFR is normal or slightly reduced. No significant urinary sediment is seen. Proteinuria in the nephrotic range is present. Selective proteinuria is seen (there is selective excretion of low molecular weight protein like albumin and absence of high molecular weight protein like globulin in the urine). Selective presence of low molecular weight protein in urine indicates a good prognosis (Fig. 7.3).

History of recent URI, allergies or immunisations are present in some cases.

Renal biopsy—light microscopic examination is normal (Fig. 7.4). Foot process fusion is seen under electron microscope.

Immunofluorescence test is negative.

Minimal change disease is highly steroid responsive. About 90% of children and 50% of adults enter remission following 8 weeks of steroid therapy. Prednisolone 1 mg/kg daily for 4 weeks followed by 1 mg/kg for 4 weeks on alternate days for adults.

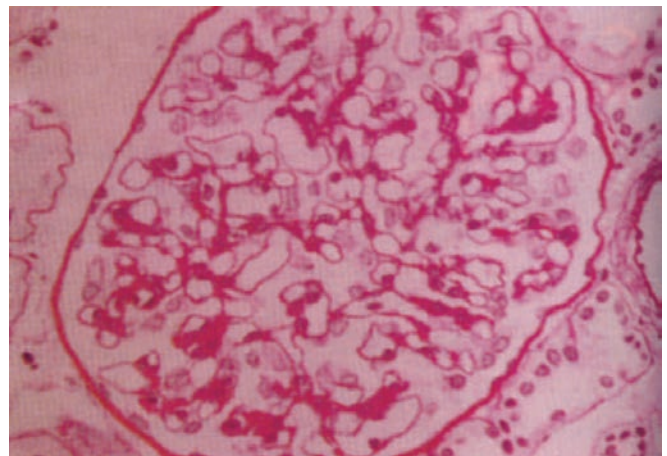

Fig. 7.4: Minimal change disease—normal glomerulus

Patients who relapse during or shortly after withdrawal of steroids and those who relapse more than 3 times/year should be treated with cyclophosphamide, chlorambucil, or cyclosporine.

Use any one of the drug:

Cyclophosphamide – 2 mg/kg/day PO eight weeks.

Chlorambucil – 0.2 mg/kg/day PO for eight weeks.

Cyclosporine – 5mg/kg/day PO for 6-12 months.



Causes

1. Idiopathic
2. Drugs—NSAID, rifampicin, IFN-alpha
3. Hodgkin's disease
4. HIV.

Membranous GN

This occurs commonly in adults, accounting for 30–40% of nephrotic syndrome in them.

Patients present with oedema, nephrotic proteinuria and normal BP, GFR and urine sediment. Hypertension, mild renal insufficiency and abnormal urine sediment may develop later.

Renal vein thrombosis is common.

Underlying disease such as SLE, hepatitis B, solid tumours and intake of drugs such as captopril or penicillamine should be sought for.

Glucocorticoids have failed to show consistent improvement in proteinuria. Cyclophosphamide, chlorambucil and cyclosporine reduces proteinuria and slow the decline in GFR.

Alternative agents include mycophenolate mofetil, rituximab, and possibly pentoxifylline.

30% of patients progress to ESRD.

Mesangial Proliferative Glomerulonephritis

This accounts for approximately 5% of idiopathic nephrotic syndrome. It is common in older children and young adults.

They present with microscopic to gross haematuria and selective or non-selective proteinuria depending on the severity of the disease.

Some patients are steroid-responsive and have a benign course. Other patients who are steroid-nonresponsive have a poor prognosis, developing renal failure 5–10 years after diagnosis.

Focal and Segmental Glomerulosclerosis

This accounts for about 10–15% of idiopathic nephrotic syndrome. It is more commonly seen in adults in the age group of 20–30 years.

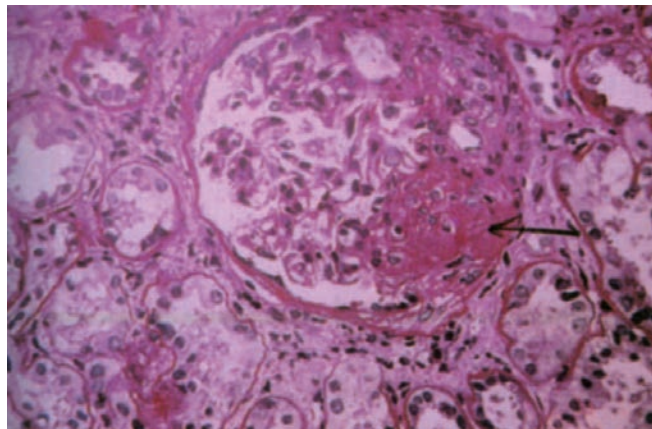

Fig. 7.5: Focal proliferative glomerulonephritis—mesangial hypercellularity; segmental sclerosis (3-6 O' clock position)

Proteinuria is present and is usually non-selective. Hypertension, reduced GFR, abnormal tubular function and abnormal urinary sediments (leucocyturia, haematuria) are seen. Hyperlipidaemia is severe in cases with focal sclerosis (Fig. 7.5).

Prognosis is variable. In steroid responsive patients, prognosis is good, but in steroid unresponsive patients and in patients with heavy proteinuria rapid progression to end stage renal failure occurs within a few months. Cyclosporine, as an adjunctive therapy to steroids, may be beneficial in some cases.

Prednisone 60 mg PO daily for three months can be tried. In resistant cases, add cyclosporine 5 mg/kg/day PO or cyclophosphamide 2 mg/kg/day PO or mycophenolate mofetil 1000–3000 mg/day.

This type progresses to CKD and ESRD in 5-10 years.

Diabetic Nephropathy

Clinical features include proteinuria, hypertension, azotemia and bacteriuria. Proteinuria may develop 10–15 years after onset of DM, progress to nephrotic syndrome, and then lead to renal failure over 3–5 years.

Pathology

1. Thickening of glomerular basement membrane (earliest)
2. Diffuse glomerulosclerosis
3. Intercapillary glomerulosclerosis (Kimmelsteil-Wilson disease) is pathognomic.

Treatment with ACE inhibitors may delay the onset of nephropathy. Aggressive management of hypertension and restriction of dietary proteins may delay the onset of renal failure (Fig. 7.6).

Renal transplantation is somewhat less successful than in nondiabetics.

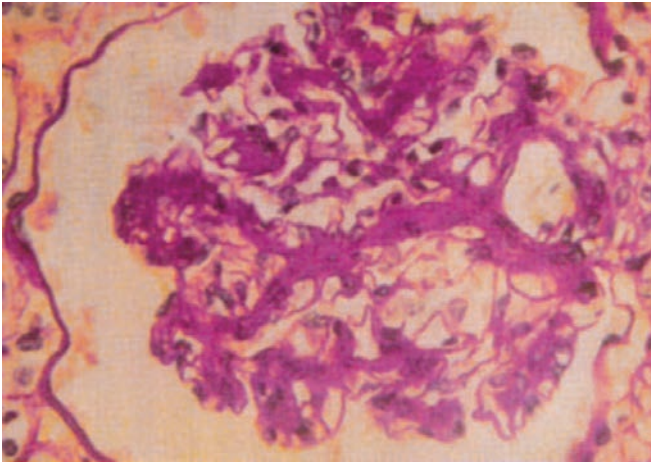

Fig. 7.6: Diffuse intercapillary glomerulosclerosis—diabetes mellitus

Evaluation of Nephrotic Syndrome

1. 24-hour urine for protein, creatinine clearance
2. Serum albumin, cholesterol, complement
3. Urine protein electrophoresis
4. Rule out SLE, diabetes mellitus
5. Review drug exposure
6. Renal biopsy
7. Consider malignancy (in elderly patient with membranous GN or minimal change disease)
8. Consider renal vein thrombosis (if membranous GN or symptoms of pulmonary embolism are present).



Treatment

1. Bed-rest
2. If GFR > 60 ml/min, no dietary restriction required. If GFR < 60 ml/min dietary protein restriction of 0.8 gm/kg/d + 1 gm protein/gm proteinuria
3. Diuretics relieve oedema but do not treat the underlying disorder. Overzealous use of diuretics should be avoided as the patients are often intravascularly depleted and may precipitate prerenal failure
4. Salt-free albumin infusion may help to alleviate symptoms of oedema temporarily
5. Treatment of the underlying cause or precipitating factor
6. Daily weight recording (aim to lose 1 kg/day)
7. Proteinuria may be controlled by ACE inhibitors.
8. Anticoagulation is indicated for patients with deep vein thrombosis, arterial thrombosis and pulmonary oedema.



Complications

1. Venous thrombosis and pulmonary embolism (urinary loss of antithrombin III, low plasma volume, increased clotting factors II, V, VII, VIII and X)
2. Infections (pneumococcal peritonitis)
3. Hypercholesterolaemia (atherosclerosis, xanthomata)
4. Hypovolaemia and renal failure
5. Loss of specific binding proteins, e.g. transferrin, thyroid-binding globulin).

Glomerulonephritis

Acute Glomerulonephritis (AGN)

This is characterised by development over days of azotemia, hypertension, oedema, haematuria, proteinuria, and oliguria. Salt and water retention are due to reduced GFR and may result in circulatory congestion.

Presence of RBC casts in urine confirms the diagnosis. Proteinuria of < 3 gm/day may be present.

Most forms of AGN are mediated by humoral immune mechanisms.



Causes of Acute Glomerulonephritis

- A. Infectious disease
 - a. Poststreptococcal glomerulonephritis
 - b. Non-streptococcal postinfectious glomerulonephritis
 1. Bacterial (infective endocarditis, sepsis, pneumococcal pneumonia, typhoid fever, secondary syphilis, meningococemia and leprosy)
 2. Viral (hepatitis B and C, infectious mononucleosis, mumps, measles, varicella, vaccinia, echovirus and coxsackievirus)
 3. Parasitic (malaria, toxoplasmosis and schistosomiasis)
- B. Multisystem disease
 - a. SLE
 - b. Vasculitis
 - c. Henoch-Schönlein purpura
 - d. Goodpasture's syndrome
- C. Primary glomerular disease
 - a. Mesangiocapillary GN
 - b. Berger's disease, IgA nephropathy
 - c. Mesangial proliferative GN
- D. Miscellaneous
 - a. Guillain-Barré syndrome
 - b. Irradiation of Wilms' tumour

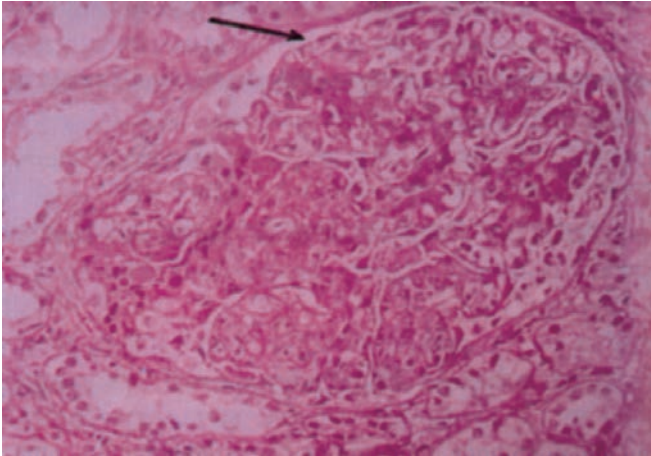

Fig. 7.7: Diffuse proliferative glomerulonephritis—swollen glomerulus with hypercellularity; Bowman's space is obliterated

- c. Diphtheria pertussis tetanus vaccine
- d. Serum sickness.

Acute Poststreptococcal GN

It is most common cause of GN in childhood. Nephritis develops 1–3 weeks after pharyngeal or cutaneous infection with 'nephritogenic' strains of group A beta-haemolytic streptococci.

Diagnosis depends on a positive pharyngeal or skin culture, rising antibody titers and hypocomplementaemia. Renal biopsy reveals diffuse proliferative GN (Fig. 7.7).

Treatment consists of correction of fluid and electrolyte imbalance.

In most cases, the disease is self-limited, although the prognosis is less favourable and urinary abnormalities are more likely to persist in adults.



Treatment

1. Strict bed-rest
2. Salt and fluid restriction
3. Diuretics
4. Management of hypertension
5. Course of penicillin to treat residual infection
6. Acute renal failure may require dialysis.



Complications

1. Susceptibility to infections
2. Acute left ventricular failure and pulmonary oedema.
3. Hypertensive encephalopathy

4. Fluid and electrolyte imbalance
5. Acute renal failure
6. Nephrotic syndrome
7. Chronic glomerulonephritis.

Postinfectious GN

This may follow other bacterial, viral, and parasitic infections. Clinical features are milder than that of poststreptococcal GN. Control of primary infection usually produces resolution of GN.

SLE

- Renal involvement is due to deposition of circulating immune complexes.
- Clinical features include arthralgias, skin rash, serositis, hair loss, and CNS symptoms.
- Diffuse GN is the most common finding, and is characterised by an elevated ESR, severe proteinuria and progressive renal insufficiency.
- Patients have a positive ANA, anti-dsDNA, and a decreased complement levels.
- Treatment includes glucocorticoids and cytotoxic agents.

WHO Classification of Lupus Nephritis

- | | |
|-----------|---|
| Class I | Normal biopsy and light microscopy, occasional mesangial deposits on immunofluorescence |
| Class II | Mesangial lupus nephritis |
| Class III | Focal segmental proliferative lupus nephritis |
| Class IV | Diffuse proliferative lupus nephritis |
| Class V | Membranous lupus nephritis |
| Class VI | ESRD. |



Treatment

Not indicated for class I and most cases of class II.

Class III and IV—glucocorticoids and immunosuppressives.

Goodpasture's Syndrome

- This is characterised by lung haemorrhage, GN, and circulating antibody to basement membrane, usually in young men. Haemoptysis may precede nephritis.
- Rapidly progressive renal failure is typical.
- Circulating anti-glomerular basement membrane (GBM) antibody and linear immunofluorescence on renal biopsy establishes the diagnosis.
- Early and aggressive use of plasmapheresis, glucocorticoids, cyclophosphamide and azathioprine resulted in remission and patients survival have improved dramatically.

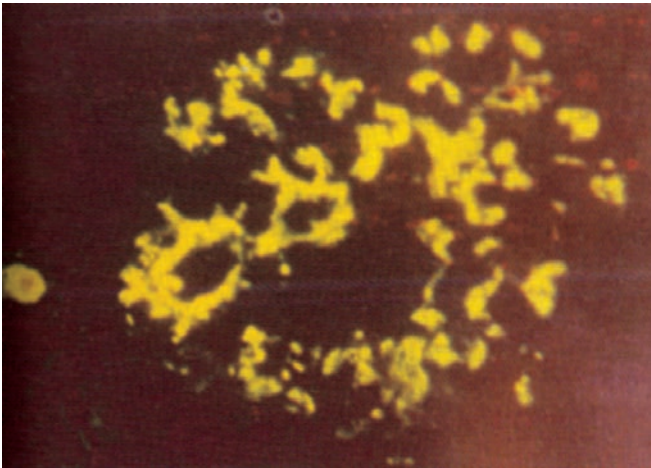

Fig. 7.8: Immunofluorescence in mesangial proliferative glomerulonephritis—IgA located in mesangial region

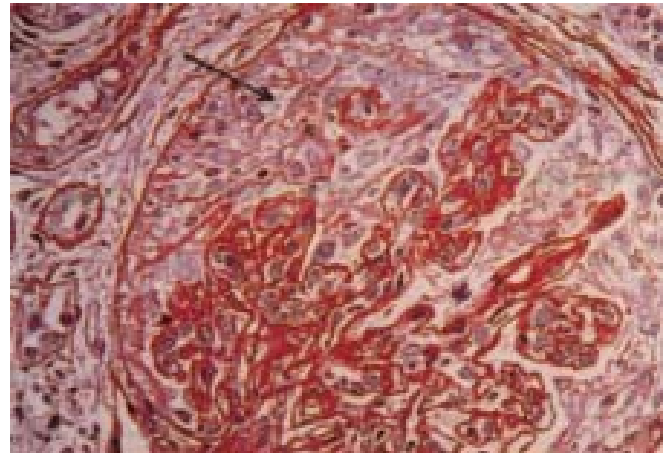

Fig. 7.9: Rapidly progressive glomerulonephritis cellular crescents

Henoch-Schönlein Purpura

- It is a generalised vasculitis causing GN, purpura, arthralgias and abdominal pain, occurring mainly in children.
- Renal involvement is manifested by hematuria and proteinuria.
- Serum IgA is increased in half of patients.
- Treatment is symptomatic.

IgA Nephropathy (Berger's Disease)

- This is the most common form of primary glomerular disease in the world.
- It progresses to end stage renal disease in 20 to 40% of patients affected over a 20 years period.
- Gross, intermittent haematuria, which is glomerular, is the presenting symptom.
- There is presence of abnormal proteinuria.
- Mesangial IgA is present (Fig. 7.8).
- No therapeutic regimen has been shown to clearly affect outcome in IgA nephropathy. However, warfarin and dipyridamole with or without cyclophosphamide may be of help.



Management of Glomerulopathies

Follow the general principles in addition to specific treatment mentioned:

- Diet—Salt restricted (sodium 2-4 g/d), potassium 40 mEq/d, phosphorus 800 mg/d
- Diuretics to correct oedema and volume overload
- Aggressive management of HTN with a goal of BP < 130/80 mm of Hg

- Combination of ACE and ARB inhibitors to reduce proteinuria
- Statins to treat hyperlipidaemias
- Consider heparin followed by long-term warfarin therapy in case of thromboembolic complication.



Complications

1. Susceptibility to infections
2. Acute left ventricular failure and pulmonary oedema
3. Hypertensive encephalopathy
4. Fluid and electrolyte imbalance
5. Acute renal failure
6. Nephrotic syndrome
7. Chronic glomerulonephritis.

Rapidly Progressive GN

- This is characterised by gradual onset of haematuria, proteinuria and renal failure, which progresses over a period of weeks to months.
- Crescentic GN is usually found on renal biopsy (Figs 7.9 and 7.10).
- Fifty percent of patients require dialysis within 6 months of diagnosis.
- Combinations of glucocorticoids in pulsed doses, cytotoxic agents (azathioprine, cyclophosphamide), and intensive plasma exchange may be useful.



Causes of Rapidly Progressive GN

1. Immune complex GN (45%)
 - a. Idiopathic proliferative GN
 - b. MPGN

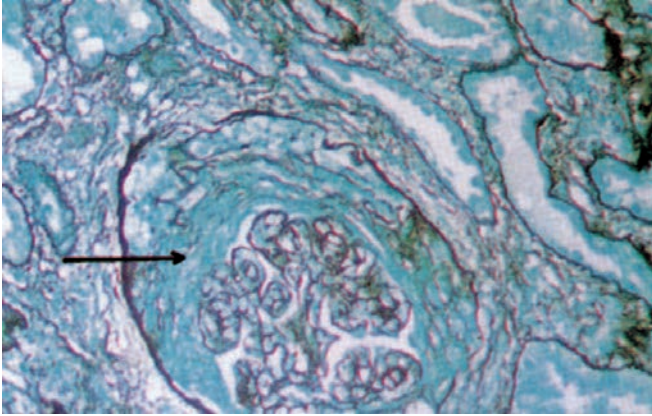

Fig. 7.10: Fibrocellular crescentic glomerulonephritis

- c. Postinfectious GN
- d. Crescentic GN
- e. Lupus nephritis
- f. Cryoglobulinaemia
- g. Bacterial endocarditis
- h. IgA nephropathy
- i. HSP.
- 2. Pauci immune GN (45%)
 - a. Wegener’s granulomatosis
 - b. Microscopic polyarteritis
 - c. Drugs—Ciprofloxacin
- 3. Anti-GBM 10%
 - a. Goodpasture’s disease.

Chronic GN

This is characterised by persistent urinary abnormalities, slow progressive impairment of renal function, symmetrically contracted kidneys, moderate to heavy proteinuria, abnormal urinary sediment (especially RBC casts).

The time to progression to ESRD is variable, hastened by uncontrolled hypertension and infections.

Inherited Salt Losing Tubulopathies (Hypokalaemia with Metabolic Alkalosis)

Features	Syndromes		
	Bartter’s	Gitelman’s	Liddle
Potassium	Low	Low	Low
Metabolic alkalosis	+	+	+
Blood pressure	Normal	Normal	High
Urinary calcium	High	Low	Normal
Serum magnesium	N/Low	Low	Normal
Renin	High	High	N/Low
Aldosterone	High	High	N/Low
Defective channel	Na ⁺ /K ⁺ /Cl ⁻	Na ⁺ /Cl ⁻	E - Na ⁺

Tubulointerstitial Disease of Kidney

Tubulointerstitial diseases constitute a diverse group of acute and chronic hereditary and acquired disorders involving renal tubules and supporting structures.

Functionally, they may result in nephrogenic diabetes insipidus with polyuria, nocturia, non-anion gap acidosis, salt wasting, and hypo or hyperkalaemia. Azotemia is common. Proteinuria is modest, hypertension is less common, and anaemia may be severe.



Causes of Tubulointerstitial Disease

- A. *Toxins*
 - 1. Exogenous toxins
 - a. Analgesic nephropathy
 - b. Lead nephropathy
 - c. Miscellaneous nephrotoxins (antibiotics, cyclosporine, radiographic contrast media, heavy metals)
 - 2. Metabolic toxins
 - a. Acute uric acid nephropathy
 - b. Gouty nephropathy
 - c. Hypercalcaemic nephropathy
 - d. Hypokalaemic nephropathy
 - e. Miscellaneous (hyperoxaluria, cystinosis)
- B. *Neoplasia*
 - 1. Lymphoma
 - 2. Leukaemia
 - 3. Multiple myeloma
- C. *Immune disorders*
 - 1. Hypersensitivity nephropathy
 - 2. Sjögren’s syndrome
 - 3. Amyloidosis
 - 4. Transplant rejection
 - 5. AIDS
- D. *Vascular disorders*
 - 1. Arteriolar nephrosclerosis
 - 2. Atheroembolic disease
 - 3. Sickle cell nephropathy
 - 4. Acute tubular necrosis
- E. *Hereditary renal diseases*
 - 1. Hereditary nephritis (Alport’s syndrome)
 - 2. Medullary cystic disease
 - 3. Medullary sponge kidney
 - 4. Polycystic kidney disease
- F. *Infectious injury*
 - 1. Acute pyelonephritis
 - 2. Chronic pyelonephritis
- G. *Miscellaneous disorders*
 - 1. Chronic urinary tract obstruction
 - 2. Vesicoureteral reflux
 - 3. Radiation nephritis.



Acute Interstitial Nephritis

- Drugs are a leading cause of this type of renal disease
- It presents with acute oliguria and sometimes fever, rash and arthralgias
- In addition to azotemia, tubular dysfunction may be present
- Common drugs causing this disorder are methicillin and other penicillins, sulfonamides, diuretics, rifampicin, cimetidine, cephalosporin and allopurinol. NSAIDs cause interstitial nephritis with nephrotic syndrome.
- Eosinophilia is common. Urine analysis shows RBCs, pyuria and eosinophiliuria.
- On renal biopsy, interstitial oedema with WBC infiltration is present.
- This disorder commonly responds to withdrawal of offending drug, and most patients have good recovery. Glucocorticoids may promote recovery.

Chronic Interstitial Nephritis

- Analgesic nephropathy is an important cause of this disorder and results from prolonged consumption of a combination of analgesics, usually of phenacetin and aspirin.
- Manifestation includes uraemia, acute papillary necrosis, sterile pyuria, or renal calculi. Patients are often women with headaches, anaemia, and GI symptoms.
- Renal function stabilizes with total cessation of drugs.
- *Medullary sponge kidney* is a disorder, usually sporadic, of ectatic collecting ducts that present as haematuria, urinary infection, distal renal tubular acidosis (RTA), and/or nephrolithiasis in the fourth and fifth decades.

Polycystic Kidney Disease

Two modes of inheritance are seen:

1. Autosomal recessive form is a rare type of infantile polycystic kidney disease and is usually fatal in the first year of life.
 - Mutation in PKHD₁ (Polycystic kidney and hepatic disease) gene on chromosome 6.
2. Autosomal dominant form is a more common type of adult polycystic kidney disease (APKD).
 - 85% cases—Mutation in PKD₁ gene on chromosome 16.
 - 15% cases—Mutation in PKD₂ gene on chromosome 4.

It affects men and women equally.

Small cysts present in infancy and subsequently enlarge till the kidneys contain numerous cysts and become asymmetrically enlarged, and nodular on palpation (Fig. 7.11).



Fig. 7.11: Polycystic kidney (autopsy specimen)



Common Clinical Features

1. Flank pain and vague abdominal discomfort.
2. Acute loin pain or renal colic due to haemorrhage into the cysts.
3. Hypertension may appear after the age of 20 years.
4. Nocturia, haematuria and urinary infection appear in the third or fourth decade.
5. Uraemia.

Hepatic cysts and intracranial aneurysms also may be present. Azotemia is usually progressive. Diagnosis is by IVP or ultrasound.



Treatment

1. Control of hypertension (as hypertension accelerates development of renal failure)
2. Treatment of UTI promptly
3. Sodium chloride replacement in patients with inability to conserve sodium.

Lipid soluble antimicrobials that have good tissue penetration such as quinolones, cotrimoxazole (trimethoprim and sulfamethoxazole), are used to treat infected cysts.

Medullary cystic disease manifests with polyuria, acidosis, and salt wasting, which precedes slowly progressive renal failure.

Acute Kidney Injury/Acute Renal Failure (ARF)

ARF is a syndrome characterised by rapid decline in GFR (hours to days), retention of nitrogenous waste

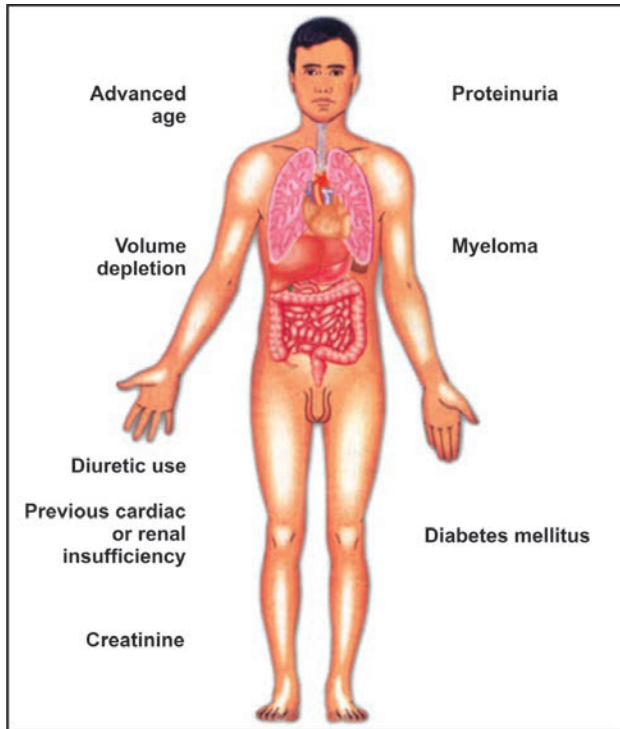

Fig. 7.12: Predisposing factors for AKI

products, and perturbation of ECF volume and electrolyte and acid-base disturbances.

This condition comprises of a rapidly rising serum urea, creatinine and K^+ , usually (but not invariably) with anuria or oliguria (< 15 ml/hr). Only half of the patients with ARF have anuria or oliguria. A preserved urine output implies a mild disorder and a better prognosis (Fig. 7.12).

RIFLE Criteria for Acute Kidney Injury

Category	GFR criteria	Urine output criteria
Risk	Increased creatinine $\times 1.5$ (or) GFR reduction $> 25\%$	< 0.5 ml/kg/hour \times 6 hours
Injury	Increased creatinine $\times 2$ (or) GFR reduction $> 50\%$	< 0.5 ml/kg/hour \times 12 hours
Failure	Increased creatinine $\times 3$ (or) GFR reduction $> 75\%$ (or) Serum creatinine > 4 mg/dL	< 0.3 ml/kg/hour \times 24 hours (or) Anuria $\times 12$ hours
Loss	Persistent AKI with complete loss of kidney function > 4 weeks	
ESRD	End stage renal disease > 3 months	



Causes of ARF

1. Pre-renal failure is due to decreased effective extracellular volume.

- a. Loss of fluid—vomiting, diarrhoea, burns, haemorrhage, diuretics
 - b. Redistribution of fluid—hepatic disease, nephritic syndrome, intestinal obstruction, pancreatitis, peritonitis, malnutrition
 - c. Decreased cardiac output—cardiogenic shock, HF due to MI, myocarditis, arrhythmias, valvular disorders; pulmonary emboli, cardiac tamponade
 - d. Peripheral vasodilatation—hypotension, sepsis, anaphylactic shock, hypoxaemia, therapy with interleukin-2, or interferons
 - e. Efferent arterial vasodilatation—ACE inhibitors
 - f. Renal vasoconstriction—hepato-renal syndrome, α -adrenergics, sepsis, prostaglandin synthesis inhibition, hypercalcaemia
2. *Intrarenal failure*
 - a. Hypotension
 - b. Sustained prerenal failure
 - c. Postoperative and postpartum haemorrhage
 - d. Rhabdomyolysis
 - e. Drugs (aminoglycosides, NSAIDs)
 - f. Contrast dye
 - g. Glomerulonephritis
 - h. Vasculitis
 - i. Interstitial nephritis.
 3. *Postrenal failure*
 - a. Intrarenal (crystals, calculi, papillary necrosis)
 - b. Extrarenal (prostate enlargement, pelvic or bladder neoplasm, retroperitoneal neoplasm or fibrosis, urethral or bladder neck obstruction)

Fractional excreted sodium =

$$\frac{[\text{Urine Na}/\text{Serum Na}]}{[\text{Urine Cr}/\text{Serum Cr}]} \times 100$$

Renal failure index = $\frac{\text{Urine Na} \times \text{Serum creatinine}}{\text{Urine creatinine}}$

ATN

This is due to ischaemic or toxic injury acting on renal vessels, glomeruli, and/or tubules causing decreased GFR and increased intratubular pressure.

Ischaemic ATN may be due to abrupt hypoperfusion or any condition causing severe pre-renal failure, particularly in elderly patients or when nephrotoxins are present.

Nephrotoxic ATN can result from exogenous or endogenous causes.

Exogenous nephrotoxins include:

1. Aminoglycosides
2. Contrast dye.



Characteristic Features of ADPKD and ARPKD

Features	ADPKD * (Adult type)	ARPKD** (Infantile type)
1. Inheritance pattern	Autosomal dominant	Autosomal recessive
2. Prevalence	1/400 to 1/1000	Rare
3. Age of onset	Usually adults	Neonates, children
4. Presenting symptom	Loin pain, haematuria, infection of renal cysts	Abdominal mass, renal failure, failure to thrive
5. Haematuria	Common	May be present
6. Recurrent upper urinary tract infection	Common	May be present
7. Renal calculi	Common	Uncommon
8. Hypertension	Common	Common
9. Method of diagnosis	Ultrasound	Ultrasound
10. Renal size	Normal to very large	Large

* Autosomal dominant polycystic kidney disease (may be associated with cysts in liver, spleen, pancreas, ovaries, uterus, broad ligament, bladder, testis, epididymis, lungs and thyroid; Cardiac anomalies like MVP, MR, AR, TR and intracranial berry aneurysms)

** Autosomal recessive polycystic kidney disease

Urinary Indices Useful in Distinguishing Pre-renal from Renal Causes of Oliguria

Indices	Pre-renal	Renal (acute tubular necrosis)
Urine osmolality (mOsm/kg)	> 500	< 350
Urine sodium (mEq/L)	< 20	> 40
Urine/serum creatinine	> 40	< 20
Urine/serum osmolality	> 1.2	< 1.2
Fractional excreted sodium	< 1	> 1
Renal failure index	< 1	> 1
Urine specific gravity	> 1.020	< 1.010

Endogenous nephrotoxins include:

1. Myoglobin released after muscle trauma
2. Intravascular haemolysis.



Clinical Features

Patients with prerenal failure usually have volume contraction, hypotension or impaired cardiac function. Diagnosis is confirmed when renal perfusion improves with volume repletion, improvement in cardiac function or repair of renal artery stenosis.

Postrenal failure may be evident from a distended bladder, large prostate, pelvic mass or hydronephrosis. The pattern of urinary flow may indicate total

obstruction (anuria) or partial obstruction (polyuria). Crystals or infection may be evident in urinary sediment.

ARF due to intrinsic renal disease may require a renal biopsy for diagnosis. RBC casts and heavy proteinuria suggest GN or vascular inflammatory disease. Interstitial nephritis may cause fever, skin eruption and pyuria with eosinophils in the urinary sediment.

The ischaemic ARF consists of three phases.

1. *Initiation phase*: It takes hours to days. It is the initial period of renal hypo-perfusion during which ischaemic injury is evolving.
2. *Maintenance phase*: It takes one to two weeks. It is the phase in which renal injury is established with low urine output resulting in uraemic complications.
3. *Recovery phase*: This phase is characterised by repair and regeneration and gradual return of GFR to normal. It results in marked diuresis.

Course

ATN begins with diminishing urine output within a day of the insult and may cause anuria.

Oliguria lasts for 10–14 days. If oliguria persists > 2–3 weeks, other diagnoses should be considered.

The daily increments in BUN and creatinine average 10–20 mg/dl and 0.5–1.0 mg/dl respectively, but may be higher in catabolic states.



Complications

1. Sodium and water overload
2. Hypertension
3. CCF
4. Hyperkalaemia (due to decreased excretion)
5. Metabolic acidosis with an anion gap (due to retention of acids)
6. Hyperphosphataemia (due to decreased excretion)
7. Hypocalcaemia
8. Hypermagnesaemia
9. Hyperuricaemia
10. Anaemia
11. Infection
12. GI bleeding
13. Paralytic ileus
14. Pericarditis.

Recovery

During the recovery phase, urine volume increases progressively. BUN and creatinine level-off and then begin to fall. Major complications of ARF may first appear



during this stage in the form of fluid and electrolyte depletion.



Management of ARF

1. Search for and correct prerenal and postrenal causes.
2. Search for evidence of ischaemic or nephrotoxic injury or renal parenchymal disease.
3. In ATN, if patient is volume overloaded, high dose of furosemide IV (20 times the serum creatinine value) can be given. In patients who are not volume overloaded 500 to 1000 ml of normal saline is infused over 30 to 60 minutes.
4. Conservative therapy
 - a. Urinary catheter to accurately detect urine output (however, it should not be kept for a long-time due to danger of UTI)
 - b. Strict intake and output chart
 - c. Daily weight measurement
 - d. Limit fluids to 500 ml + previous day's losses
 - e. Avoid nephrotoxic drugs
 - f. Treat hyperkalaemia and acidosis
5. Dialysis for volume overload, pericarditis, GI bleeding, symptomatic uraemia, severe hyperkalaemia or acidosis.
6. Pigment induced renal injury occurring during haemolysis or rhabdomyolysis is treated with alkalinisation of urine.
 - If urinary output improves after the bolus dose of furosemide, it can be given as IV infusion 20 mg/hour or repeated bolus doses 6th hourly. Addition of a thiazide diuretic enhances diuresis in furosemide responsive patients.
 - Acetylcysteine—600 mg PO bid for 4 days may reduce the incidence of contrast nephropathy (Start one day prior to procedure).
 - Aminoglycoside induced AKI is non-oliguric and avoid using it in elderly, patients with hepatic or renal dysfunction. Limit the duration of therapy to less than 5-10 days.
 - 2-3 ampules of NaHCO_3 in 1 L of 5% dextrose IV infusion to alkalanise the urine in pigment induced renal injury.
 - Rasburicase 15 mg/kg IV infusion is effective in acute uric acid nephropathy (tumour lysis syndrome)
 - Prednisone 60 mg Po daily is advocated to hasten recovery in drug induced acute interstitial nephritis.
 - Abdominal compartment syndrome causing renal failure as a result of abdominal fluid accumulation following trauma, surgery, or massive ascites (Intra abdominal pressure > 25 mm of Hg) can be cured by abdominal decompression.

Indications for Urgent Dialysis

1. Potassium persistently high (> 6.0 mEq/L)
2. Acidosis (pH < 7.2)
3. Daily rise in level of blood urea more than 30 mg/dL or a total rise of blood urea more than 300 mg/dL.
4. CO_2 combining power < 13 mEq/L
5. Serum creatinine > 7 mg/dl
6. Pulmonary oedema not responding to diuresis.
7. Pericarditis
8. Cardiac tamponade
9. High catabolic state with rapidly progressive renal failure.

Chronic Kidney Disease

Chronic kidney disease is due to several aetiologies lasting for more than 3 months leading to reduction in nephron number and function as evidenced by either structural abnormalities or proteinuria and frequently leading to end stage renal failure.

CKD—Risk factors:

- Family history of heritable renal disease
- Hypertension
- Diabetes mellitus
- Autoimmune disorders
- Older age
- Past episode of ARF
- Current evidence of kidney damage

In stages 1 and 2—Patients are asymptomatic.

In stages 3 and 4—Patients are symptomatic with positive clinical signs and laboratory parameters.

In stage 5—Patients require dialysis or renal replacement therapy.

Stages of Chronic Kidney Disease

Stage	Features	GFR(ml/min)
1	CKD with normal or increased GFR	> 90
2	Mild CKD	60-89
3	Moderate CKD	30-59
4	Severe CKD	15-29
5	ESRD	<15

Chronic Renal Failure (CRF)

CRF refers to the permanent loss of renal function, which culminates in signs and symptoms termed uraemia. Unlike ARF, from which recovery is frequent, CRF is not reversible and may lead to a vicious cycle with progressive loss of remaining nephrons.

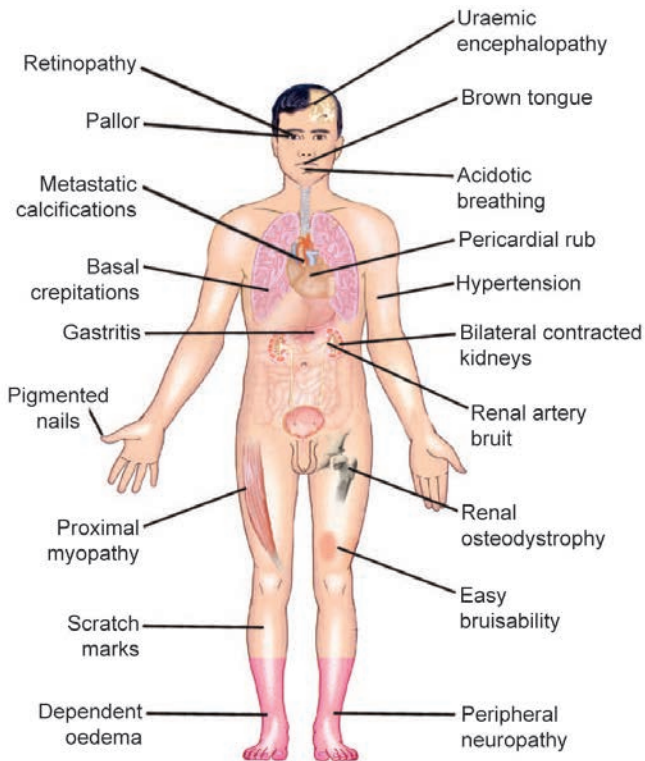

Fig. 7.13: Clinical features in chronic renal failure



Common Causes

1. Diabetic nephropathy
2. Hypertension
3. Chronic glomerulonephritis
4. Polycystic kidney disease
5. Chronic pyelonephritis
6. Interstitial nephritis.

Symptoms, Signs and Consequences of CRF (Fig. 7.13)

Patient may be asymptomatic.

1. Nausea and anorexia
2. Lethargy
3. Pruritus
4. Polyuria

are the earliest symptoms of CRF.

The causes of *uraemic syndrome* are unknown, but may be due to the following:

1. Failure of renal excretion of solutes and products of metabolism.
2. Loss of metabolic and endocrine function of the healthy kidney.

3. Retained toxins (breakdown products of proteins and amino acids).
4. Presence of urea in abundance (malaise, anorexia, and vomiting).
5. Nitrogenous compounds (guanidinosuccinic acid) contributes to platelet dysfunction.
6. Larger compounds are implicated in uraemic neuropathy.
7. Parathyroid hormone in high levels contributes to development of renal osteodystrophy.

Other signs and symptoms of CRF may be due to the following consequences:

1. Changes in body fluid volume or composition
 - a. Na retention
 - b. Hyponatraemia (dilutional)
 - c. Hyperkalaemia
 - d. Metabolic acidosis (anion gap acidosis due to retention of sulphate, phosphate and other unmeasured anions)
 - e. Hyperphosphataemia
 - f. Hypocalcaemia
 - g. Hypermagnesaemia
 - h. Hyperuricaemia

Hyperphosphataemia and hypocalcaemia develop when GFR falls to < 25% of normal (< 30 ml/min).

2. *Cardiopulmonary*
 - a. CCF (pulmonary oedema may be due to increased capillary permeability in the absence of volume overload)
 - b. Hypertension
 - c. Pericarditis (due to uraemia or other systemic disease)
 - d. Accelerated atherosclerosis
 - e. Pneumonitis
 - f. Pleuritis
3. *Haematologic*
 - a. Anaemia (normochromic, normocytic due to diminished erythropoiesis, shortened RBC survival, and in some cases, blood loss)
(Other causes of anaemia—chronic inflammation, deficiency of iron, folate or B₁₂, hyperparathyroidism/bone marrow fibrosis, haemoglobinopathies)
 - b. Poor hemostasis (prolonged bleeding time, lower platelet factor III activity, mild thrombocytopenia and platelet function abnormalities)
 - c. Leucocyte abnormalities
4. *Neuromuscular*
 - a. Encephalopathy
 - b. Peripheral neuropathy
 - c. Dialysis dementia
 - d. Restless leg syndrome

5. *Gastrointestinal*
 - a. Anorexia, nausea, vomiting (especially early in the morning)
 - b. Peptic ulcer
 - c. Ascites
 - d. Viral hepatitis
6. *Endocrine*
 - a. Secondary hyperparathyroidism (due to decreased phosphate excretion by the kidney)
 - b. Glucose intolerance (due to resistance to insulin)
 - c. Amenorrhoea
 - d. Impaired testicular function
 - e. Impotence
7. *Skin*
 - a. Pruritus (due to uraemia)
 - b. Ecchymosis
 - c. Hyperpigmentation (yellow hyperpigmentation due to retention of urochromes and discolouration due to hemochromatosis).
 - d. Nephrogenic fibrosing dermatopathy—Progressive subcutaneous induration involving arms and legs.

With progressive nephron loss, the ability of the diseased kidney to concentrate urine is impaired, resulting in polyuria and nocturia. At this point of time, restriction of fluid and salt may be hazardous as it may lead to be severe extracellular volume depletion.

Late in CRF, the remaining nephrons cannot excrete normal amount of sodium, so that dietary salt is retained, usually resulting in hypertension and volume overload with CCF and oedema. At this point of time, fluid and salt restriction is mandatory.

The spectrum of abnormalities in uraemia, i.e. signs and symptoms typically appear late, when GFR is < 25% of normal.



Investigations

1. Urine analysis
2. Blood biochemistry
3. Ultrasonography to assess the size of the kidneys.

In CRF, both the kidneys are small and contracted (< 8 cm length is taken as contracted kidney). The normal size of the kidney corresponds to 3 times the length of the L₁ vertebra, or two-third of the additive lengths of T₁₁ T₁₂ and L₁ vertebrae (Figs 7.14 to 7.16).

CRF with enlarged kidneys

- a. Diabetes mellitus with CRF
- b. Polycystic kidney disease
- c. Amyloid kidney
- d. Bilateral obstruction (hydronephrosis)
- e. Myeloma kidney
- f. HIV

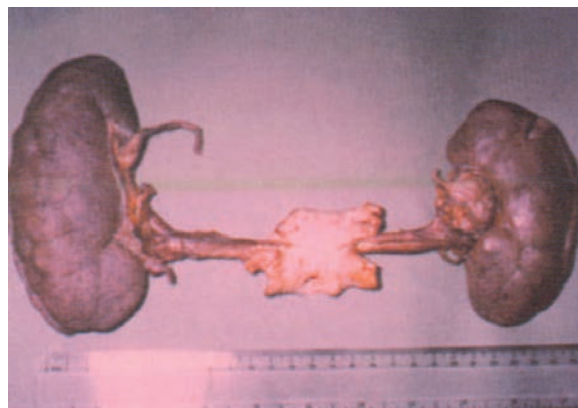

Fig. 7.14: Renal artery stenosis with contracted kidney (autopsy specimen)



Fig. 7.15: Aortogram—left sided renal artery stenosis with contracted kidney

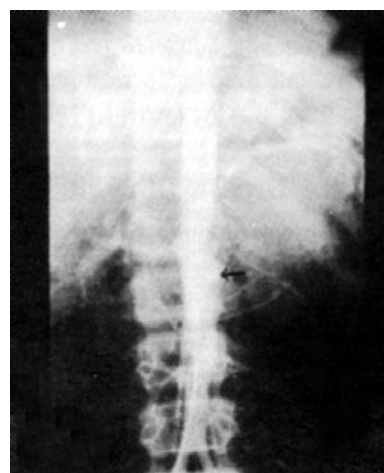

Fig. 7.16: Aortoarteritis—renal artery stenosis

4. Renal biopsy is contraindicated in presence of CRF but may be considered if renal size is normal.



Treatment

1. Treat any reversible cause (relieve obstruction, avoid nephrotoxic drugs and treat underlying infection).
2. Monitor and treat hypertension, as it may cause slow decline in renal function, and fluid and electrolyte abnormalities.
3. Dietary advice
 - a. Adequate calories
 - b. Vitamins and iron
 - c. Salt restriction (if there is fluid and sodium overload and in presence of hypertension)
 - d. Dietary protein restriction in CRF

GFRml/min	protein gm/kg/d
>60	no restriction
25-60	0.6 gm/kg/d including 0.35 gm/kg/d of HBV
5-25	0.6 gm/kg/d including 0.35 gm/kg/d of HBV
	or
	0.3 gm/kg/d supplemented with essential amino acids or keto-analogue. (HBV-high biological value protein)
 - e. To avoid diet containing potassium (coconut water, fruits and fruit juices)
 - f. Diet to predominantly contain carbohydrates.
4. Anaemia may respond to erythropoietin. Treat anaemia with epoetin 50-100 units/kg SC three times/week in dialysis patients and once weekly in CKD patients or darbepoetin 0.45 mcg/kg SC once a week and the dosing can be extended to every 4th week on reaching the target level of Hb.

Iron store should be assessed periodically when on epoetin therapy. If transferrin saturation is <20% or ferritin is <200 mg/dL, consider iron repletion (iron dextran 1,000 mg IV or ferric gluconate 125 mg IV eight doses or iron sucrose 100 mg IV ten doses. Oral iron therapy is effective in CKD patients when not on dialysis. Better response to epoetin therapy is achieved by replacement of iron store.
5. Treatment of renal bone disease by lowering phosphate with phosphate binders like calcium carbonate 300-1200 mg/8 hr orally.
6. To avoid aluminium containing drugs (antacids) as aluminium accumulation may cause encephalopathy.
7. Vitamin D replacement (Alphacalcidol in the dose of 0.25-1 mg daily orally).

8. Calcium supplements (only after reduction of phosphate, to reduce the risk of metastatic calcification).
9. Treatment of hiccups with chlorpromazine 25 mg/8 h orally.
10. Treatment of oedema may require high doses of diuretics (frusemide 250 mg-2 gm/day IV).
11. Dialysis in preparation for renal transplantation.
12. Renal transplantation is the definitive treatment.

Secondary hyperparathyroidism:

Correction of hyperphosphataemia and hypocalcaemia will help reduce PTH levels.

Active vitamin D – calcitriol 0.25 to 1 mcg PO daily
19- nor-1,25 dihydroxyvitamin D₂ Paricalcitol 1-5 mcg PO daily in pre-dialysis patients or 2-10 mcg IV with each dialysis. It is a synthetic vitamin D analog with a lower incidence of hypercalcaemia or Doxercalciferol another synthetic analog 1-5 mcg PO daily in pre-dialysis patients or 5-20 mcg PO thrice weekly with dialysis.

Cinacalcet—30-120 mg PO daily to increase the sensitivity of the calcium sensing receptor in the parathyroid.

Stage 4 CKD with PTH levels above target and 25-OH vitamin D levels low (< 30 ng/mL) should receive ergocalciferol supplementation for six months – 50,000 IU PO weekly for 4 weeks and then once a month.

When on vitamin D preparations, monthly measurement of serum calcium and phosphorus are essential to avoid hypercalcaemia.

Parathyroidectomy is indicated in severe hypercalcaemia and severe hyperparathyroidism (PTH > 1,000) despite maximal medical therapy.

End-stage Renal Disease

Common Causes—Incidence

- | | |
|--|-----|
| 1. Diabetes mellitus | 40% |
| 2. Hypertension | 30% |
| 3. Glomerulopathies | 15% |
| 4. Interstitial nephritis | 5% |
| 5. Cystic disease/Hereditary disorders | 5% |
| 6. Miscellaneous | 5% |

Dialysis

It is a process by which an attempt is made to maintain a normal internal homeostasis artificially, in the absence of normal renal function.

It is the usual therapy for end stage renal disease (ESRD), i.e. when GFR is < 5 ml/min.

1. Haemodialysis (HD)

Blood flows opposite to the dialysis fluid, and substances are exchanged down a concentration gradient across a semipermeable membrane, between the two compartments.

Indications

- ARF
- Toxins
- Drugs
- CRF patients awaiting renal transplantation
- Patients with CRF in whom quality of life has deteriorated.

Access

This is commonly achieved by creation of a subcutaneous AV fistula or shunt.

Alternatives include prosthetic fistulas and percutaneous subclavian or femoral catheters.



Complications of Haemodialysis

Complications Arising due to Access

- Infection
- Thrombosis
- Vascular compromise
- High output CCF.



Complications Arising due to Dialysis Procedure

- Haemorrhage
- Hypotension
- Cardiac ischaemia
- Cramps, nausea, vomiting
- Seizures
- Hypoventilation, hypoxaemia
- Anticoagulation leading to bleeding diathesis
- Air embolism
- Haemolysis.

Many manifestations of uraemia persist with chronic haemodialysis, although they are less severe.

- Anaemia may be aggravated by blood loss and folate deficiency.
- Accelerated atherosclerosis is common.
- Pericarditis, diverticulosis, hepatitis (most frequently non-A, non-B), impotence and acquired renal cysts are other complications.
- Aluminium intoxication can cause dialysis dementia, a usually fatal syndrome of speech dyspraxia, seizures and myoclonus.

- Disequilibrium refers to CNS symptoms ranging from nausea to seizures related to volume depletion and osmolar shifts, usually occurring with initiation of treatment.
- Renal osteodystrophy may progress or appear in the form of osteomalacia with bone pain and fractures.

Amyloidosis

Results from accumulation of beta-2 microglobulin. This syndrome presents as carpal tunnel syndrome, tenosynovitis of hand, shoulder arthropathy, bone cyst, cervical spondyloarthropathy and cervical pseudotumours. X-ray shows cysts in carpal bones and femoral neck. Amyloid tumour masses can be best appreciated by USG or CT.

2. Haemofiltration

- This can be used continuously for treatment of acute renal failure.
- Blood is filtered across a semipermeable membrane, allowing removal of small molecules.
- It is easy to use and causes smaller fluid shifts so that fewer hypotensive episodes occur.
- It achieves good clearance values.

3. Intermittent Peritoneal Dialysis

The dialysate is introduced into the peritoneal cavity via a catheter kept for 10–30 minutes and then withdrawn. This procedure is repeated. It is mainly used for treatment of ARF in hospitals without access to haemodialysis.

4. Continuous Ambulatory Peritoneal Dialysis (CAPD)

In this, a permanent catheter is inserted into the peritoneum via a subcutaneous tunnel. Up to 2 litres of dialysate is introduced and exchanged up to 5 times a day. The patient is not tied to a machine and uraemic anaemia is less common than with HD.



Complications of Peritoneal Dialysis

- Peritonitis (usually *Staphylococcus*, *Streptococcus*, or *Coliforms*)
- Catheter blockage
- Weight gain and poor diabetic control (dialysate fluid has high sugar content)
- Pleural effusion.

Renal Transplantation

It is a common and ultimate therapy for ESRD.



- Graft acceptance is determined by genetic compatibility of donor and recipient, based on matching of antigens (Ag) of HLA genes. Class I Ag is detected by a lymphocyte assay and class II Ag ('DR') by the mixed lymphocyte culture.
- Graft survival in living related transplants improves with matching of class I Ag. Class II Ag matching is more important to success of cadaveric transplants.
- Presensitization (the presence of antibody against donor ABO or class I Ag) is detected by a positive cross-match and is a contraindication to transplantation.
- Pretransplant blood transfusion enhances graft survival, although some patients may be sensitised.

Contraindications to Kidney Transplantation

Absolute contraindications	Relative contraindications
1. Reversible renal involvement	1. Elderly age group
2. Ability of conservative measures to maintain useful life	2. Severe bladder or urethral abnormalities
3. Major extrarenal complications (cerebrovascular or coronary disease, neoplasia)	3. Iliofemoral occlusive disease
4. Active infection	4. Diabetes mellitus
5. Active glomerulonephritis	5. Severe psychiatric disease
6. Previous sensitisation to donor tissue	6. Oxalosis



Complications

1. Rejection
2. Obstruction at ureteric anastomosis
3. Persistent hypertension
4. Atherosclerosis
5. Side effect of immunosuppression (opportunistic infection with *Pneumocystis carinii*, CMV, fungi, bacteria)
6. Skin malignancy and lymphoma
7. Drug-induced complications
 - a. Azathioprine (bone marrow suppression, malignancy)
 - b. Cyclosporine (nephrotoxicity, hepatotoxicity)
 - c. Glucocorticoids (infection, diabetes mellitus, adrenal suppression, peptic ulcer disease, hypertension, osteoporosis).

Peritransplant (< 1 month):

- Wound infection
- Herpes virus infection
- Oral candidiasis
- Urinary tract infection

Early (1-6 months):

- *Pneumocystis carinii* infection
- Cytomegalovirus infection
- Legionella infection
- Listeria infection
- Hepatitis B and C infection

Late (> 6 months):

- Aspergillus infection
- Nocardia infection
- Polyoma virus infection
- Herpes Zoster infection
- Hepatitis B and C infection

Rejection

Rejection may be

1. Hyperacute (immediate graft failure due to presensitization)
2. Acute (within weeks to months with a rise in creatinine, hypertension, fever, graft tenderness, volume overload, and low urine output)
3. Chronic (months to years with ongoing loss of renal function and hypertension).

Immunosuppressive Therapy in Renal Transplantation

1. Azathioprine is begun at transplantation and continued throughout. It is useful in preventing acute rejection.
2. Cyclosporine improves survival rates, and decreases severity of acute rejection episodes. It allows lower dosage of glucocorticoids, when used concomitantly.
3. Glucocorticoids are used for maintenance and are given in higher doses to reverse acute rejection. Chronic rejection is often steroid resistant.

Newer modalities

4. Mycophenolate mophetil is now preferred over azathioprine because of lesser GI toxicity and minimal bone marrow suppression.
5. Fungal macrolides like tacrolimus and sirolimus
6. Antibodies to lymphocytes, OKT3 against CD3 molecule, basiliximab and daclizimab (antibody against IL2 receptor).

Fluid and Electrolyte Imbalance

Sodium

Sodium is normally present in predominant concentration in the extracellular fluid compartment. Normal serum concentration of sodium is 135 to 145 mEq/L.



Hyponatraemia

Hyponatraemia is said to be present when serum sodium is less than 130 mEq/L. It may be caused by excess body water relative to sodium and occurs in conditions in which total extracellular fluid may be normal, increased, or decreased.

Hypovolaemic Hyponatraemia

This results when sodium losses, usually from GI tract, exceed losses of water, often associated with partial volume replacement with water and impaired water diuresis.

Examples

- Extrarenal losses (vomiting, diarrhoea, pancreatitis, and loss of water through skin and respiratory tract). In this form, the urine sodium excretion is < 10 mEq/L.
- Renal losses (diuretics, renal injury, partial obstruction, RTA, salt wasting nephropathy, adrenal insufficiency). In this form, the urine sodium excretion is > 20 mEq/L.

Hypervolaemic Hyponatraemia (Dilutional Hyponatraemia)

This occurs when increase in total body water exceeds increase of sodium.

Examples

- Nephrosis, cirrhosis, congestive heart failure (urine sodium excretion is < 10 mEq/L)
- Renal failure (acute or chronic) (urine sodium excretion is > 20 mEq/L as the renal tubules are not able to reabsorb sodium).

Normovolaemic Hyponatraemia

This occurs in syndrome of inappropriate vasopressin secretion (SIADH) in which excessive vasopressin mediates increased water reabsorption, thereby causing dilutional hyponatraemia.

Common causes are:

- Ectopic production of vasopressin by tumours (e.g. oat cell cancer of lung)
- Endogenous overproduction from neurohypophysis due to pulmonary disease (pneumonia, abscess, tuberculosis), PEEP ventilation
- CNS disorders (tumours, stroke, meningitis, encephalitis, trauma, subarachnoid haemorrhage)
- Drugs (morphine, tricyclics, cyclophosphamide, nicotine, NSAIDs, sulfonyleureas)
- Hypothyroidism
- Addison's disease.

Symptoms

These include confusion, anorexia, lethargy, disorientation and cramps. When sodium drops abruptly to <120 mEq/L, seizures, hemiparesis, and coma may develop.



Treatment

- Initial assessment of the volume status must be done.
- Hypovolaemic patients should receive normal saline. Any mineralocorticoid deficiency should be corrected.
- In hypervolaemic hyponatraemia, water intake should be restricted. Further improvement may occur with appropriate treatment of CCF, albumin infusion in nephrosis.
- Patients with SIADH require water restriction and demeclocycline.
- Hypertonic saline infusion is reserved for situations where there is profound hyponatraemia (serum sodium <120 mEq/L).

Hypernatraemia

Hypernatraemia is said to be present when serum sodium is > 150 mEq/L. It is caused by deficit of water relative to sodium.

Hypovolaemic Hypernatraemia

This occurs in the following conditions:

- Extra renal losses (excessive sweating, fluid losses from GI tract, pancreatitis, fluid losses from skin and respiratory tract). In this form, the urine sodium excretion is <10 mEq/L.
- Renal losses (diuretics, hyperglycaemia, acute or chronic renal failure, mannitol infusion, urea diuresis). In this form, the urine sodium excretion is >20 mEq/L.

Normovolaemic Hypernatraemia

This occurs in the following conditions:

- Extra renal losses (insensible losses through skin and respiratory tract). In this form, the urine sodium excretion is >20 mEq/L.
- Renal losses (diabetes insipidus both central, and nephrogenic). In this form the urine sodium excretion is <10 mEq/L.

Hypervolaemic Hypernatraemia

This occurs as a result of gain of water and sodium in the following conditions:



- a. Primary aldosteronism
- b. Cushing's syndrome
- c. Congenital adrenal hyperplasia
- d. Hypertonic saline infusion
- e. Hypertonic haemodialysis or peritoneal dialysis.

In these conditions, the urine sodium excretion is >20 mEq/L.

Symptoms

- These include altered mental status, twitching, seizures and coma.
- Acute severe hypernatraemia (> 160 mEq/L) dehydrates cerebral cells and may rupture cerebral vessels causing irreversible neurologic sequelae and substantial mortality.



Treatment

1. Hypovolaemic hypernatraemia is initially treated with isotonic saline until volume is repleted, then with 0.45% saline.
2. Hypervolaemic hypernatraemia is best treated with hypotonic fluids and loop diuretics or, when indicated by dialysis. Patients with central diabetes insipidus should receive aqueous vasopressin or the intranasal analogue desmopressin. Nephrogenic diabetes insipidus responds to thiazides and sodium restriction.

Potassium

Potassium is a predominant intracellular cation. Extracellular potassium balance is determined by oral intake and renal excretion. Normal extracellular potassium concentration ranges from 3.5 to 4.5 mEq/L. Ninety per cent of K intake is excreted by the kidney, mostly secreted by the distal nephron, a process augmented by aldosterone, high cell K content, and alkalosis.

Factors that modulate intracellular potassium balance include insulin, beta-2 adrenergic agonist, and alkalosis, which promote potassium uptake by cells. Acidosis shifts potassium out of cells.

Hypokalaemia

It is said to be present when the extracellular potassium concentration is <3.5 mEq/L.



Causes of Hypokalaemia

1. *Gastrointestinal*
 - a. Deficient dietary intake
 - b. Gastrointestinal disorders (vomiting, diarrhoea, villous adenoma, fistulae, ureterosigmoidostomy)

2. Renal

- a. Metabolic alkalosis
 - b. Diuretics, osmotic diuresis
 - c. Excessive mineralocorticoid effects
 - i. Primary aldosteronism
 - ii. Secondary aldosteronism (including malignant hypertension. Bartter's syndrome, juxtaglomerular cell tumour)
 - iii. Licorice ingestion
 - iv. Glucocorticoid excess (Cushing's syndrome, exogenous steroids, ectopic ACTH production)
 - d. Renal tubular diseases
 - i. Renal tubular acidosis
 - ii. Leukaemia
 - iii. Antibiotics
3. Hypokalaemia due to shift into cells (no depletion)
 - a. Hypokalaemic periodic paralysis
 - b. Insulin effect
 - c. Alkalosis.

Salient Features

- Muscle weakness, ileus, polyuria, and ECG changes (U waves, increased Q-T interval, and flat T waves).
- Severe hypokalaemia causes flaccid paralysis and cardiac arrest.
- The cause of hypokalaemia is usually evident on presentation.
- Inadequate intake or diarrhoea is suggested by a urinary potassium excretion of <25 mEq/L.
- Greater urinary potassium losses suggest vomiting, current diuretic use, or renal tubular losses.
- Excess urinary potassium is lost when the patient has vomiting, as the kidney tries to retain H^+ to counteract the development of metabolic alkalosis as a consequence of vomiting. This is done by secreting K^+ instead of H^+ in the distal tubule in exchange for Na^+ , which is absorbed there.

Acidosis in the presence of hypokalaemia suggests

- a. Diarrhoea
- b. Renal tubular acidosis
- c. Diabetic ketoacidosis (on initiation of insulin therapy).

Mineralocorticoid excess is suggested by increased renal potassium loss and hypertension.



Treatment

1. Dietary supplements, using KCl, suffice in mild case.
2. In oedematous patients on diuretics, dietary supplementation and addition of potassium sparing agents (e.g. aldactone) are useful. GI losses should be replaced with IV KCl ≤ 20 mEq/hr.

3. Severe symptomatic hypokalaemia requires larger doses (20–40 mEq/hr), with cardiac monitoring and frequent plasma potassium levels.
4. Hypokalaemia with digitalis toxicity also requires urgent correction.

Hyperkalaemia

It is said to be present when extracellular potassium concentration is > 5.5 mEq/L.



Causes of Hyperkalaemia

- Inadequate excretion*
 1. Renal failure
 - a. Acute renal failure
 - b. Severe chronic renal failure (GFR < 10 ml/min)
 - c. Tubular disorders
 2. Adrenal insufficiency
 - a. Hypoaldosteronism
 - b. Addison's disease
 3. Diuretics which inhibit potassium secretion (spironolactone, triamterene, amiloride).
- Shift of potassium from tissues*
 1. Tissue damage (muscle crush, haemolysis, internal bleeding, massive blood transfusion)
 2. Drugs (succinylcholine, digitalis poisoning)
 3. Acidosis
 4. Hyperosmolality
 5. Hyperkalaemic periodic paralysis.
- Excessive intake*
- Pseudohyperkalaemia*
 1. Thrombocytosis
 2. Leukocytosis
 3. Poor venepuncture technique
- In vitro* haemolysis.

Salient Features

- The most important clinical effects of hyperkalaemia are cardiac conduction changes and arrhythmias.
- The ECG changes with developing hyperkalaemia are as follows:
Peaked T-waves in the precordial leads are followed by diminished R-wave, wide QRS, prolonged PR interval, loss of P-wave, and ultimately a sine wave.
- Hyperkalaemia may also cause ascending muscle weakness.



Treatment

1. Hyperkalaemia is a potentially dangerous condition and must be treated promptly. The guidelines for

the management of hyperkalaemia in varying grades of severity is summarised.

Acid-base Balance and its Disorders

About 50 to 100 millimoles of hydrogen ions are released from cells into 15 to 20 litres of extracellular fluid each day. Despite fluctuations in the rate of release during the day, homeostatic mechanisms keep the extracellular pH in the normal range of 7.35 to 7.45.

Regulation of normal pH depends on normal functioning of the lungs and kidneys.

Definitions

An *acid* can dissociate to produce hydrogen ions.

A *base* can accept hydrogen ions.

An *alkali* dissociates to produce hydroxyl ions.

Buffering is the process by which a strong acid (or base) is replaced by a weaker one in the presence of a buffer. The hydrogen ion is taken up by the buffer, and the change in pH after addition of acid is less than it would be in the absence of the buffer.

Example:

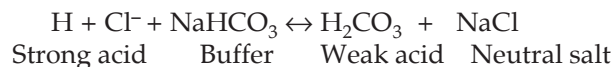

pH is a function of the ratio of HCO_3^- (regulated by the kidney) to PCO_2 (regulated by the lungs). It is a measure of hydrogen ion activity.

Acidosis is due to gain of acid or loss of alkali. Causes may be metabolic (fall in serum HCO_3^-) or respiratory (rise in PCO_2).

$$\text{pH} = \log \frac{1}{[\text{H}^+]}$$

Alkalosis is due to loss of acid or addition of base, and is either metabolic (increased serum HCO_3^-) or respiratory (decreased PCO_2).

To limit the change in pH, metabolic disorders evoke an immediate compensatory response in ventilation. Compensation to respiratory disorders by the kidneys takes days.

Hydrogen Ion Homeostasis

The maintenance of normal hydrogen ion homeostasis is by 3 mechanisms.



Treatment of Hyperkalaemia

Treatment	Indication	Dose	Onset	Duration	Mechanism	Note
Calcium gluconate	K ⁺ > 6.5 mEq/l with advanced ECG changes	10 ml of 10% solution IV over 2–3 min	1–5 min	30 min	Antagonises toxicity of hyperkalaemia	Fastest action; Repeat in 5 min if abnormal ECG persists; hazardous in presence of digitals
Plain insulin + Glucose	Moderate hyperkalaemia peaked T-waves only	10 units IV + 50 ml of 50% IV	15–45 min	4–6 hr	Moves potassium into cells	Glucose unnecessary if blood sugar elevated
NaHCO ₃	Moderate hyperkalaemia	90 mEq over 5 min	Immediate	Short	Moves potassium into cells	Most effective when acidosis is present
Kayexalate + Sorbitol	Moderate hyperkalaemia	Orally 30 g with 50 ml 20% sorbitol; rectally 50 gm in 200 ml 20% sorbitol enema	1 hr	4–6 hr	Removes potassium	Each gram Kayexalate remove about 1 mEq K orally and about 0.5 mEq K rectally
Furosemide	Moderate hyperkalaemia; Serum creatinine < 3 mg%	20–40 mg IV	15 min	4 hr	Kaliuresis	Most useful if inadequate K excretion contributes to hyperkalaemia
Dialysis	Hyperkalaemia with renal failure		Immediate after starting	Variable	Removes potassium	Haemodialysis most effective; also improves acidosis

1. Control of CO₂ by the Respiratory Centre and Lungs

The partial pressure of CO₂ in plasma is normally about 5.3 kPa (40 mm Hg). Maintenance of this level depends on the balance between production by metabolism and loss through the pulmonary alveoli.

Increased CO₂ production stimulates respiration, thereby driving out excess CO₂.

Some disease of lungs, or abnormalities of respiratory control, primarily affect the PCO₂.

2. Bicarbonate Generation by the Erythrocytes

Haemoglobin is an important blood buffer.

Erythrocytes lack aerobic pathways and therefore produce little CO₂. Plasma CO₂ diffuses into the cell along a concentration gradient, where carbonate dehydratase catalyses its reaction with water to form carbonic acid. As H₂CO₃ dissociates, much of the H⁺ is buffered by haemoglobin. The concentration of HCO₃⁻ in the erythrocyte rises, and it diffuses into the extracellular fluid along a concentration gradient; electrochemical neutrality rises, and it diffuses into the extracellular fluid along a concentration gradient; electrochemical neutrality is maintained by diffusion of chloride in the opposite direction into the cell (*the chloride shift*).

3. The Kidneys

Two renal mechanisms control HCO₃⁻ concentration in the extracellular fluid.

a. Bicarbonate Reabsorption

The luminal surfaces of the renal tubular cells are impermeable to bicarbonate, which therefore cannot be reabsorbed directly. It must first be converted to CO₂ in the tubular lumen, and an equivalent amount of CO₂ is converted to bicarbonate within the tubular cell. The mechanism depends on the action of carbonate dehydratase within the tubular cell, and on H⁺ secretion from the cell into the lumen in exchange for the sodium filtered with the bicarbonate.

b. Bicarbonate Generation

The mechanism in the renal tubular cell for generating bicarbonate is identical to that of bicarbonate reabsorption, but there is net loss of H⁺ from the body as well as a net gain of HCO₃⁻. This mechanism is therefore well suited to correcting acidosis.

Urinary buffers other than bicarbonate are involved in the bicarbonate generation linked to H⁺ secretion. The two most important of these are phosphate and ammonia.

i. Phosphate buffer pair

Phosphate is normally the most important buffer in the urine. It appears in the form of monohydrogen

phosphate ion in the glomerular filtrate, and this can accept H^+ , formed by the carbonate dehydratase mechanism, to become dihydrogen phosphate. Bicarbonate generation can then continue.

ii. *Ammonia*

- The enzyme glutaminase, which is present in renal tubular cells, catalyses the hydrolysis of the terminal amino group of glutamine to form glutamate and the ammonium ion.
- Urinary ammonia allows H^+ secretion and therefore bicarbonate formation to continue after other buffers have been depleted.
- Ammonium ion dissociates to form ammonia and H^+ .
- Ammonia can diffuse out of the cell into the tubular lumen and if the luminal fluid is acidic, will be retained thereby avid combination with H^+ and excreted in urine.
- The H^+ liberated into the cell is incorporated into glucose by gluconeogenesis.

Disturbances of Hydrogen Ion Homeostasis

I. ACIDOSIS

1. Metabolic Acidosis

The primary abnormality in metabolic acidosis is a reduction in HCO_3^- concentration which causes a fall in pH. The bicarbonate may be lost in the urine or gastrointestinal tract, its generation may be impaired, or it may be used in buffering H^+ more rapidly than it can be generated.

In the normal subject, over 80% of plasma anions is accounted for by chloride and bicarbonate. The remaining 20% or so (sometimes referred to as *unmeasured anion*) is made up of protein, and the normally low concentration of urate, phosphate, sulphate, lactate and other organic anions. The protein concentration remains relatively constant, but the levels of other unmeasured anions can vary considerably in disease.

Anion Gap

The difference between the total concentration of measured cations, sodium and potassium, and that of measured anions, chloride and bicarbonate is known as the anion gap. It is normally about 15 to 20 mEq/l.

Example

$$[Na^+] + [K^+] = [HCO_3^-] + [Cl^-] + [A^-]$$

$$140 + 4 = 25 + 100 + 19 \text{ mEq/L}$$

The anion gap in this example is 19 mEq/L.

Acidosis with increased anion gap

The anion gap is increased when there is increased production of unmeasured anions, to compensate for the fall in HCO_3^- in conditions like

- Diabetic ketoacidosis
- Lactic acidosis
- Methanol poisoning
- Salicylate poisoning
- Acute and chronic renal failure.

Acidosis with normal anion gap

The anion gap may remain normal when

- There is an equivalent loss of cation [Na^+] and anion [HCO_3^-] whereby the unmeasured anion remains in the normal range to maintain electrochemical neutrality.

Examples:

- Diarrhoea
- Intestinal fistulae
- Generalised renal tubular dysfunction.

- There is an increased concentration of [Cl^-] to compensate for the loss of [HCO_3^-]. A condition known as *hyperchloremic acidosis* develops.

Examples:

- Ureterosigmoidostomy
- Carbonic anhydrase inhibitors
- Renal tubular acidosis.



Clinical Features

There is stimulation of the respiratory centre leading to Kussmaul's respiration. With severe acidosis, myocardial function is impaired. Peripheral vasodilatation occurs and there is fall in BP. Confusion and drowsiness may occur.

The plasma findings in metabolic acidosis are:

- $[HCO_3^-]$ always low
- PCO_2 usually low (compensatory change)
- pH low.

Treatment is of the underlying cause.

2. Respiratory Acidosis

The primary defect is CO_2 retention, usually due to impaired alveolar ventilation. The consequent rise in PCO_2 is the constant finding in respiratory acidosis.

Compensatory changes in [HCO_3^-] are initiated by the acceleration of the carbonate dehydratase mechanism in erythrocytes and renal tubular cells by the high PCO_2 . [HCO_3^-] generation is speeded up, tending to compensate for the raised PCO_2 .



Example:

- a. Acute respiratory failure (bronchopneumonia, or acute severe asthma)
- b. Chronic respiratory failure (chronic obstructive airway disease).

The arterial findings in respiratory acidosis are:

1. PCO_2 always raised
2. In acute respiratory failure.
 - a. pH low
 - b. $[\text{HCO}_3^-]$ high normal or slightly raised, as compensatory changes take sometime to occur.
3. In chronic respiratory failure
 - a. pH normal or low, depending on chronicity (time for compensation to occur)
 - b. HCO_3^- raised.

II. ALKALOSIS

1. Metabolic Alkalosis

In metabolic alkalosis, the primary abnormality in the bicarbonate buffering system is a rise in $[\text{HCO}_3^-]$. There is little compensatory change in PCO_2 . It is less common than metabolic acidosis.

It is characterised by

- i. Increase in plasma bicarbonate
- ii. Rise in pH
- iii. Small compensatory rise in PaCO_2 .

Conditions producing metabolic alkalosis are:

- i. Vomiting or gastric aspiration
- ii. Diuretics (thiazides, furosemide)
- iii. Hypokalaemia (due to movement of $[\text{H}^+]$ into the cell)
- iv. Primary and secondary hyperaldosteronism
- v. Cushing's syndrome
- vi. Administration of liquorice, carbenoxolone
- vii. Administration of exogenous alkali (oral or IV bicarbonate).



Clinical Features

Acute alkalosis may cause tetany due to acute fall in plasma ionised calcium and enhanced release of acetylcholine. Confusion and drowsiness may occur.

Treatment is of the underlying cause.

2. Respiratory Alkalosis

In respiratory alkalosis, the primary abnormality is a fall in PCO_2 . The compensatory change is a fall in $[\text{HCO}_3^-]$. A primary fall in PCO_2 is due to abnormally rapid or deep respiration, when the CO_2 transport capacity of the pulmonary alveoli is relatively normal.

Causes of respiratory alkalosis are:

- (i) Hysterical overbreathing
- (ii) Raised intracranial pressure or brainstem lesions
- (iii) Hypoxia
- (iv) Pulmonary oedema
- (v) Lobar pneumonia
- (vi) Excessive artificial ventilation.

The fall in PCO_2 slows the carbonate dehydratase mechanisms in renal tubular cells and erythrocytes. The compensatory fall in $[\text{HCO}_3^-]$ tends to correct the pH.

The arterial blood findings in respiratory alkalosis are:

- (i) PCO_2 always reduced
- (ii) $[\text{HCO}_3^-]$ low normal or low
- (iii) pH raised or normal.

Treatment is of the underlying cause.

Approach to Acid-base Disorders

Introduction

Normal pH of blood is maintained between 7.35-7.45 inspite of 40-60 millimoles of H^+ ions added to body fluids due to daily metabolism. This is achieved by 3 systems.

1. Chemical buffering system
2. Respiratory regulation of PaCO_2
3. Renal regulation of HCO_3^-

Acid base disorders can arise as a result of either primary respiratory abnormality or primary metabolic abnormality or mixed problem.

Basic Concepts

Acidosis	: pH < 7.35
Alkalosis	: pH > 7.45
Respiratory acidosis	: $\text{PaCO}_2 > 45$ mm Hg
Respiratory alkalosis	: $\text{PaCO}_2 < 35$ mm Hg
Normal HCO_3^-	: 21-30 milliequi/litre

A primary respiratory pathology is reflected as an alteration in PaCO_2 , whereas a primary metabolic problem will be reflected as an alteration in HCO_3^- level.

Hypoxic index: In conditions with primary lung pathology, the oxygenation mechanism is defective and will be reflected by inappropriate PaO_2 for the given FIO_2 . (FIO_2 is the percentage of oxygen in the inspired air. Patient breathing room air FIO_2 is 21%). Hypoxic index will help us to find out whether the oxygenation is sufficient for the given FIO_2 .

Hypoxic index = $\text{PaO}_2/\text{FIO}_2$

Normal value is 400-450. Low value suggests primary lung pathology.

Algorithm for ABG Analysis

I. Assessment of history and clinical examination will give clue regarding interpretation of ABG.

II.

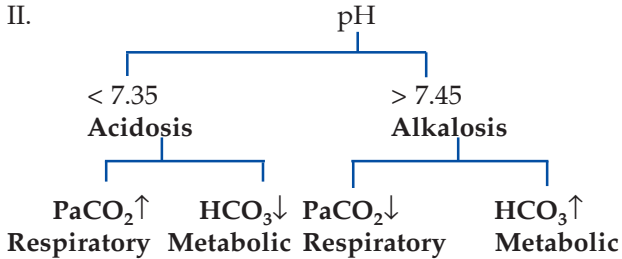

Primary Respiratory

In case of respiratory acidosis, we have to look for metabolic compensation. It is calculated by the formula,

The expected pH decrease for the increase in PaCO_2

In acute respiratory acidosis = $0.08 \times (\text{PaCO}_2 - 40)/10$

In chronic respiratory acidosis = $0.03 \times (\text{PaCO}_2 - 40)/10$

If actual pH > expected pH => Respiratory acidosis + Metabolic alkalosis

If actual pH < expected pH => Respiratory acidosis + Metabolic acidosis.

Primary Metabolic

In case of metabolic acidosis, we have to look for respiratory compensation. It is calculated by the formula,

$$\text{Expected PaCO}_2 = (1.5 \times \text{HCO}_3) + (8 \pm 2)$$

If the actual $\text{PaCO}_2 >$ expected PaCO_2 => metabolic acidosis + respiratory acidosis

If the actual $\text{PaCO}_2 <$ expected PaCO_2 => metabolic acidosis + respiratory alkalosis

In the presence of metabolic acidosis, anion gap has to be assessed. It is given by the formula,

$$\text{AG} = \text{Na}^+ - (\text{Cl}^- + \text{HCO}_3^-)$$

Normal value = 12

Anion gap is elevated in

1. Diabetic ketoacidosis
2. Lactic acidosis
3. Toxins
4. Uraemic acidosis

Anion gap is normal in

1. Renal tubular acidosis
2. Ureterosigmoidostomy
3. Diarrhoea

In case of metabolic alkalosis, we have to look for respiratory compensation. This is calculated by the formula,

$$\text{Expected PaCO}_2 = \text{HCO}_3 + 15$$

If the actual $\text{PaCO}_2 >$ expected PaCO_2 => metabolic alkalosis + respiratory acidosis

If the actual $\text{PaCO}_2 <$ expected PaCO_2 => metabolic alkalosis + respiratory alkalosis.



Chapter 8

Nervous System

SYMPTOMS

HEADACHE

VOMITING

SEIZURES

ALTERED SENSORIUM/
LOSS OF CONSCIOUSNESS

BEHAVIOURAL
ABNORMALITIES

VISUAL
DISTURBANCES

VERTIGO

SPEECH DISORDER

DYSARTHRIA

DYSPHAGIA

WEAKNESS OF
LIMBS

SENSORY
DISTURBANCES
(positive and negative)

UNSTEADY GAIT

ABNORMAL
MOVEMENTS

SYNCOPE

FALLS

DROP ATTACKS

SIGNS

ASSESSMENT OF
CONSCIOUS LEVEL

PUPILS
EXTRAOCULAR MOVEMENTS

DYSARTHRIA

HANDWRITING

APRAXIA

AGNOSIA

CRANIAL NERVE DYSFUNCTION

WEAKNESS OF LIMBS
(bilateral/unilateral
distal/proximal
UMN/LMN type)
Reflexes

SENSORY SYSTEM
ABNORMALITIES

ROMBERG'S SIGN

GAIT ABNORMALITIES

CEREBELLAR SIGNS

INVOLUNTARY MOVEMENTS

FUNDUS CHANGES

MENINGEAL SIGNS

SPINE AND CRANIUM EX.

FEATURES OF PARKINSONISM

NEUROCUTANEOUS MARKERS

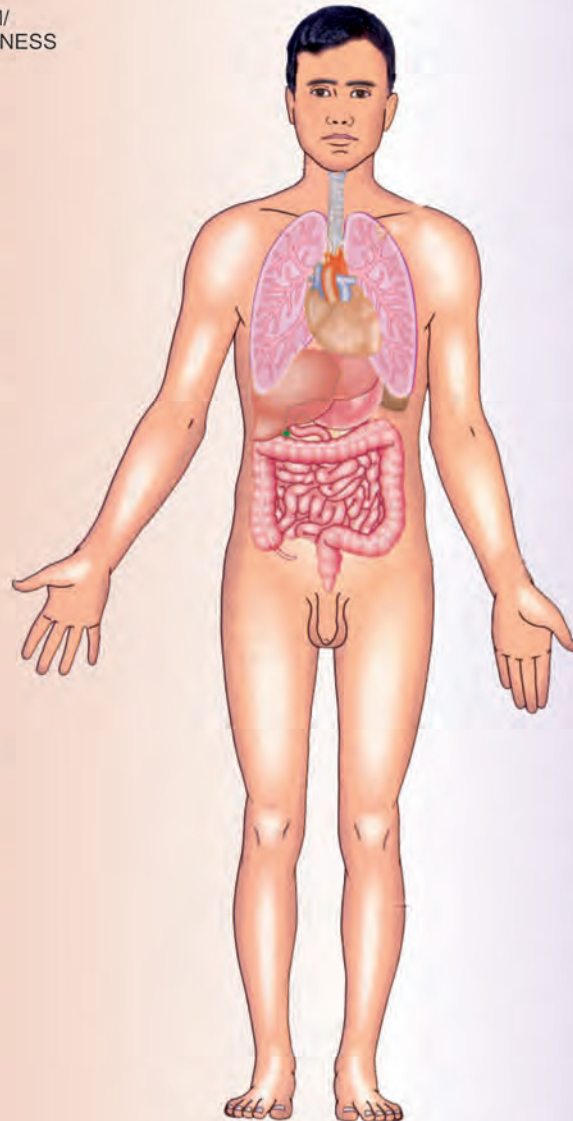

Higher Functions

Definitions

Consciousness

It is defined as the state of awareness of self and the environment.

Confusion

It is lack of clarity and coherence of thought, perception, understanding or action. It is often the first feature of cognitive impairment.

Coma

It is a state of unconsciousness in which the patient does not respond to any type of external stimuli or inner need.

Stupor (or) Semiconsciousness

It is a state of disturbed consciousness from which only vigorous external stimuli can produce arousal.

Glasgow Coma Scale (GCS)

Eye Opening

Spontaneous	4
To speech	3
To pain	2
No response	1

Best Verbal Response

Fully oriented	5
Mild confusion	4
Moderate confusion (inappropriate)	3
Severe confusion (incomprehensible)	2
No response	1

Best Motor Response

Obeys commands	6
Localises pain	5
Withdrawal to pain	4

Abnormal flexor response (decorticate posture)	3
Extensor response (decerebrate posture)	2
No response	1

GCS is useful in assessing level of consciousness in a patient with head injury.

Best total score is	15
Mild injury	13 to 15
Moderate injury	9 to 12
Severe injury	8

This gives an indication of the patient's state of consciousness and is not a substitute for neurological examination. **maximum score ~15**

minimum score= 3

Abbreviated Coma Scale (AVPU)

A alert
V responds to vocal stimuli
P responds to pain
U unresponsive.

Coma Vigil (Vegetative State)

Patient is comatose, but the eyelids are open giving the appearance of being awake. Patient may perform random limb and head movements, but there is complete inability to respond to command or to communicate.

Akinetic Mutism

This refers to a partial or fully awake patient who is immobile and silent. This state may be seen in hydrocephalus, mass in the region of third ventricle or large bilateral hemispherical lesions.

Abulia

This is a mild form of akinetic mutism, in which patient is hypokinetic, but is able to communicate. This is seen in lesions in the periaqueductal region or lower diencephalon.

Unresponsive States in Neurology

Disorder	Awareness	Sleep cycle	Motor function	Experiences suffering	Respiratory function	EEG
Persistent vegetative state	Absent	Intact	No purposeful movement	No	Normal	Polymorphic delta and theta
Brain death	Absent	Absent	None or only reflex spinal movements	No	Absent	Silent
Locked-in-syndrome	Present	Intact	Quadriplegia Preserved vertical eye movements	Yes	Normal	Normal
Akinetic mutism	Present	Intact	Paucity of movements	Yes	Normal	Non-specific slowing



Locked-in Syndrome (Pseudo Coma)

Patients are awake, alert and selectively de-efferented. They are non communicable with intact lid movements, eye movements in the vertical plane and quadriplegia with involvement of lower cranial nerves. The site of lesion is either ventral pons or bilateral medulla with intact tegmentum (which contains fibres of Reticular Activating System). Infarction of ventral pons transects all descending corticospinal and corticobulbar tracts, but spares ARAS, which maintains arousal.



Causes

1. Demyelination (central pontine myelinolysis)
2. Ventral pontine infarction (basilar artery occlusion)
3. Bilateral infarction of lateral 2/3 of cerebral peduncle
4. Peripheral disorders associated with locked in syndrome
 - a. Severe polyneuropathy
 - b. Myasthenia gravis
 - c. Neuromuscular blocking agents.

Catatonia

Patient appears awake and blink spontaneously. There is a waxy flexibility (limbs maintain the posture implemented by the examiner). This is seen in schizophrenia.

Delirium

This is synonymous with acute confusional state characterised by periods of agitation, heightened mental activity, increased wakefulness, hallucinations, motor hyperactivity and autonomic stimulation. There is an associated impairment of attention.



Causes of Delirium

Head injury
 CVA
 Cerebral infections
 Epilepsy
 Hypoglycaemia, DKA
 Hypoxia
 Renal or hepatic failure
 Electrolyte or acid-base imbalance
 Wernicke's encephalopathy
 Septicaemia, malaria, SBE, pneumonia
 Heat stroke, hypothermia
 Toxins

- Alcoholic intoxication
 - *Alcohol and drug (Barbiturates and narcotics) withdrawal

Psychiatric disorders

Acute mania
 Extreme anxiety
 Schizophrenia (auditory hallucinations)
 Hysteria.

Note: *Alcohol withdrawal causes delirium tremens which is characterised by delirium, tremors and visual hallucinations.

Dementia

It is a syndrome of acquired global or multifocal impairment of cognitive function involving decline in intellect, memory or personality in the presence of normal consciousness.



Causes of Dementia

1. Primary dementias
 - a. Alzheimer's disease (diffuse cortical atrophy)
 - b. Pick's disease (circumscribed cortical atrophy, early frontal and temporal)
 - c. Frontal lobe degeneration.
2. Secondary dementias
 - a. *Degenerative disorders*
 - Parkinson's disease
 - Hereditary ataxias
 - Progressive supranuclear palsy (Steele-Richardson syndrome)
 - Motor neuron disease
 - Huntington's chorea
 - Multiple sclerosis.
 - b. *Conditions with raised intracranial tension*
 - Primary and secondary tumours
 - Hydrocephalus
 - Chronic subdural hematoma
 - Carcinomatous meningitis.
 - c. *Vascular dementia*
 - Multiinfarct dementia
 - Lacunar infarct
 - Thalamic infarct
 - Diffuse atherosclerosis
 - Vasculitis: SLE, polyarteritis nodosa, Behcet's disease.
 - d. *Chronic infections*
 - Syphilis, GPI
 - Tuberculosis
 - Fungal, protozoal infections
 - Slow viral diseases:
 - * Subacute sclerosing panencephalitis
 - * Creutzfeldt-Jacob disease
 - * Papova virus
 - * HIV.



3. Dementia due to diffuse brain damage
 - Anoxia
 - Encephalitis
 - Acute head injury
 - Pugilistic dementia (boxers).
4. Endocrine disorders
 - Chronic hypoglycaemia
 - Hypothyroidism
 - Hypo and hyperparathyroidism
 - Adrenal insufficiency
 - Cushing's syndrome.
5. Vitamin deficiencies
 - Vitamin B₁₂ deficiency
 - Thiamine deficiency
 - Niacin deficiency.
6. Toxins
 - Alcohol
 - Drug and narcotic poisoning
 - Heavy metal intoxication
 - Dialysis dementia.
7. Dementia in adolescents and young adults
 - Wilson's disease
 - Progressive myoclonic epilepsy
 - Tuberous sclerosis
 - Leukodystrophies
 - Storage diseases.

Note: • Treatable causes

Presenile Dementia It occurs before 65 years of age (Pick's disease, Alzheimer's disease)

Senile Dementia It occurs after 65 years of age

Cortical Dementia It occurs in Pick's disease and Alzheimer's disease

Subcortical Dementia It occurs in Huntington's disease, multiple sclerosis and HIV.

Differences between Alzheimer's Disease and Pick's Disease

Features	Alzheimer's disease	Pick's disease
1. Portion of brain affected	Diffuse cortical involvement (esp. hippocampus and temporal lobes)	Confined to frontal and temporal lobes (lobar sclerosis)
2. Pathology	Neurofibrillary tangles, senile plaques seen	Pick's bodies seen
3. Age of onset	Presenile or senile	Presenile
4. Clinical features	Features of diffuse cortical involvement seen: Frontotemporal features less prominent	Prominent fronto-temporal features seen

Amnesia

It is a disorder of memory characterised by inability to remember past events and to learn new information despite normal consciousness and attention.

As a result of head injury, memory disturbance occurs for events before (*retrograde amnesia*) and after the time of injury (*post-traumatic amnesia*).

Anterograde Amnesia

Impairment in learning new material which accompanies post-traumatic amnesia.

Duration of post-traumatic amnesia indicates the severity of head injury; the ability to learn new material often being the last cognitive deficit to recover.

Transient Global Amnesia

It is a syndrome in which a previously normal person suddenly becomes confused and amnesic. It is usually of spontaneous origin but also may be due to immersion in cold or hot water, emotional stimuli, exertion, intercourse or travel in motor vehicles.

There is severe impairment of recall of recent and sometimes most distant events. Immediate memory is intact. There is no other neurological sign. It is usually benign. Rarely it may be due to temporal lobe tumour, migraine or temporal lobe epilepsy.

Examination of Higher Mental Functions

Consciousness

Find out the level of consciousness of the patient (whether the patient is comatose, stuporose or delirious).



Causes of Coma

Trauma

Cerebral contusion, concussion and laceration
Subdural haematoma
Extradural haematoma.

Cerebrovascular Disease

Subarachnoid haemorrhage
Intracerebral haemorrhage
Massive cerebral infarction
Brainstem infarction or haemorrhage
Cerebellar infarction or haemorrhage
Cerebral venous sinus thrombosis.



Infections

Meningitis
Encephalitis
Cerebral abscess
Cerebral malaria.

Seizure Disorders and Raised ICT

Epilepsy
Space occupying lesions.

Endocrine and Metabolic Disturbances

- Diabetes mellitus: Hypoglycaemia, ketoacidosis, hyperosmolar coma
- Myxoedema
- Hypocalcaemia
- Hypercalcaemia
- Hypoadrenalism
- Hypopituitarism
- Hepatic failure
- Respiratory failure
- Cardiac failure
- Uraemia
- Metabolic acidosis
- Metabolic alkalosis
- Electrolyte disturbances (hypo and hypernatraemia).

Cardiovascular Disorders

Congestive cardiac failure
Hypertensive encephalopathy
Shock
Arrhythmias.

Physical Agents

Hyperpyrexia
Hypothermia
Electric shock
Lightning.

Toxins and Others

Acute poisoning
Alcohol
Thiamine deficiency.

Tropical Coma

Cerebral malaria
Typhoid fever
Trypanosomiasis
Rabies.

Metabolic Coma

<i>Aetiology</i>	<i>Neurologic signs</i>	<i>Diagnostic workup</i>
Hypoxia	Myoclonus, flaccid muscle tone	Cardiorespiratory disorder, polytrauma,
Diabetic ketoacidosis	Clouding of consciousness/coma	Blood sugar > 400 mg with ketonuria
Hyperosmolar coma	Coma, seizure, focal signs	Blood sugar > 800 mg High serum osmolarity
Hypoglycaemic coma	Coma, seizure, focal signs	Blood sugar < 50 mg%
Hepatic coma	Asterixis, jaundice	Elevated ammonia level
Uraemia	Myoclonus, asterixis, oliguria	Raised renal parameters
Disequilibrium syndrome	Muscle cramps, seizure	Postdialysis syndrome
Hyponatraemia	Coma and seizure	Serum sodium < 126 mmol
Hypernatraemia	Muscle weakness, coma	Serum sodium > 156 mmol
Hypercalcaemia	Muscle weakness, headache	Calcium, phosphate, and parathormone
Hypocalcaemia	Tetany, seizure, coma	Calcium, phosphate and parathormone

Approach to Coma

A comatose patient has to be approached systematically to derive maximum information. The aim of physical examination is to arrive at following conclusions.

- Localisation of coma
- Aetiology of coma (structural vs metabolic)

Approach to the Patient

I. *History and general examination.*

A meticulous history and detailed general examination will give clue regarding the aetiology of coma.

II. *Neurological examination.*

The neurological examination of a comatose patient serves 3 purposes.

- To aid in determining the cause of coma
- To help determine the prognosis of coma
- To provide a base line.

For localisation of structural lesion and to assess the prognosis, the following examinations are the most helpful

- State of consciousness
- Respiratory pattern
- Pupillary size and reactivity

4. Ocular motility
5. Skeletal muscle motor response.

1. State of Consciousness

Auditory, visual and noxious stimuli of progressively increasing intensity should be applied to the patient. The maximal state of arousal, intensity of stimuli required for that and the response of the patient has to be noted. Any asymmetry in the response to stimuli points towards structural lesion.

All patients in coma should be asked to open their eyes and look up and down. Because in locked in syndrome only these voluntary movements are spared. Patient will be alert and aware, but quadriplegic with lower cranial nerve paralysis, thus mimicking coma.

2. Respiration

Respiratory patterns that are helpful in localising level of involvement are the following (Fig. 8.1):

- A. Cheyne-Stokes breathing.
- i. Rate of respiration will be around 30 per minute
 - ii. There is waxing and waning of respiration
 - iii. Waning of respiration is followed by apnoea for about 15 seconds.

Causes

- i. Bilateral hemispheric damage
- ii. Diencephalic insults
- iii. Bilateral damage anywhere between forebrain and upper pons
- iv. Prolonged circulation time as in cardiac failure.

Prognosis

- i. Stable pattern of Cheyne-Stokes respiration is a good prognostic sign

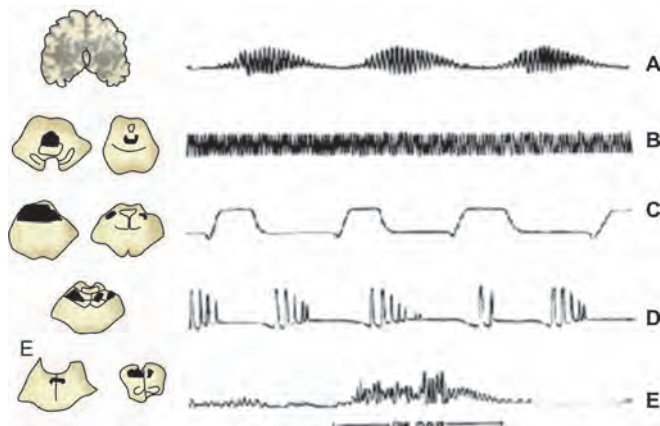

Fig. 8.1: Respiratory patterns in coma

- ii. Emergence of Cheyne-Stokes breathing in a patient with unilateral mass lesion may be a sign of herniation
 - iii. Change in pattern from Cheyne-Stokes to other patterns described is ominous.
- B. Central neurogenic hyperventilation.
- i. Refers to rapid breathing (40-70 per minute)
 - ii. Lesions of low midbrain ventral to aqueduct of Sylvius and of upper pons ventral to fourth ventricle.
 - iii. Hyperpnoea cannot be ascribed to CNS lesion if PaO_2 is $< 70-80$ mm Hg and PCO_2 is greater than 40 mmHg
- C. Apneustic breathing.
Apneustic breathing is a prolonged inspiratory gasp with a pause at full inspiration. It is caused by lesions of the dorsolateral lower half of pons.
- D. Cluster breathing.
Cluster breathing results from high medullary damage, involves periodic respirations that are irregular in frequency and amplitude, with variable pauses between clusters of breaths.
- E. Ataxic breathing.
This is irregular in rate and rhythm and is usually due to medullary lesions. Ataxic breathing and bilateral VI nerve lesion may be a warning sign of brainstem compression from an expanding lesion in posterior fossa.

3. Pupil Size and Reactivity (Fig. 8.2)

- a. *Thalamic lesions* cause small, reactive pupils, which are often referred to as *diencephalic pupils*. Similar

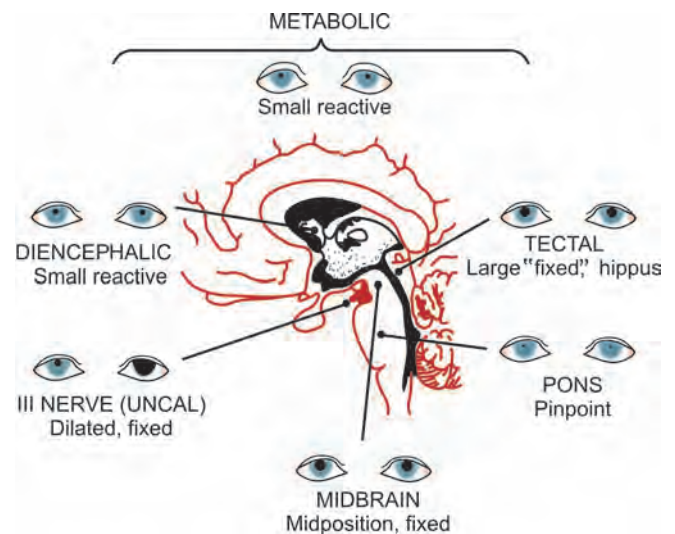

Fig. 8.2: Pupillary defects in coma



- pupillary findings are noted in many toxic-metabolic conditions resulting in coma.
- b. *Hypothalamic lesions* or lesions elsewhere along the sympathetic pathway result in Horner's syndrome.
 - c. *Midbrain lesions* produce three types of pupillary abnormality, depending on where the lesion occurs.
 - i. *Dorsal tectal lesions* interrupt the pupillary light reflex, resulting in midposition eyes, which are fixed to light but react to near, although the reaction is impossible to test in the comatose patient. Spontaneous fluctuations in size occur, and the ciliospinal reflex is preserved.
 - ii. *Nuclear midbrain lesions* usually affect both sympathetic and parasympathetic pathways, resulting in fixed, irregular midposition pupils, which may be unequal.
 - iii. Lesions of the third nerve in the brainstem, or after the nerve exits the brainstem parenchyma, cause wide pupillary dilation unresponsive to light.
 - d. *Pontine lesions* interrupt sympathetic pathways to cause small pupils (pinpoint pupils), which remain reactive, although magnification may be needed to observe this.
 - e. Lesions above the thalamus and below the pons should leave pupillary function intact, except for Horner's syndrome in medullary or cervical spinal cord lesions.
 - e. Oculopalatal nystagmus occurs due to damage to the lower brainstem involving the Guillain-Mollaret triangle, which extends between the cerebellar dentate nucleus, red nucleus and inferior olive.
 - iii. Reflex ocular movements

This constitutes:

 - a. Oculocephalic reflex (Dolls eye movement)
 - b. Vestibulo-oculogyric reflex (Cold caloric testing).
 - a. *Dolls eye phenomenon*. This is tested by sudden passive rotation of head in both directions laterally and flexion and extension of the neck while observing the motion of the eyes.
 - b. *Cold caloric testing*. Clinical caloric testing is commonly done by applying cold water to the tympanic membrane with the head tilted back 60 degrees from the horizontal. The head tilt allows maximal stimulation of the lateral semicircular canal, which is most responsible for reflex lateral eye movements. After checking to make certain that the ear canal is patent and the tympanic membrane is free of defect, 10 ml of ice-cold water is slowly injected into one ear canal. Cold water applied to the tympanic membrane causes currents to be set up in the endolymph of the semicircular canal. This results in a change in the baseline firing of the vestibular nerve and slow (tonic) conjugate deviation of the eyes toward the stimulated ear. In an awake person, the eye deviation is minimal and is corrected with a nystagmus fast phase towards the opposite side. Warm water irrigation produces reversal of flow of the endolymph, which causes a slow phase away from the stimulated ear and a normal corrective phase towards the ear. By tradition, the nystagmus is named by the direction of the fast phase. The mnemonic COWS (cold opposite, warm same) refers to the fast phases. Simultaneous bilateral cold water application results in slow phase down and fast phase up, whereas the reverse occurs with bilateral warm water application.

4. Ocular Motility

Preservation of normal ocular motility implies that a large portion of brainstem is intact, from the oculomotor nucleus in the midbrain to the vestibular nuclei at the pontomedullary junction.

Evaluation of ocular movement consists of three main elements.

- i. Abnormalities of resting position including eye deviation.
- ii. Spontaneous eye movements.
 - a. Purposeful appearing eye movements occur in locked in syndrome, catatonia, pseudocoma, and persistent vegetative state.
 - b. Rowing eye movements indicates brainstem is relatively intact and coma is due to metabolic or toxic cause or bilateral lesions above the brainstem.
 - c. Nystagmus occurring in comatose patients suggests an irritative or epileptogenic supratentorial focus.
 - d. Spontaneous conjugate vertical eye movements like ocular bobbing which is characterised by rapid downward jerk of both eyes followed by a slow return to the midposition. The centre of lesion is at Pons.

Interpretation

- i. Normal response indicate intact brainstem
- ii. Absent response indicate brainstem involvement
- iii. Abnormal dysconjugate responses occur with cranial nerve palsies, internuclear ophthalmoplegia, or restrictive eye disease.

5. Motor System

Resting posture and adventitious movements are analysed.

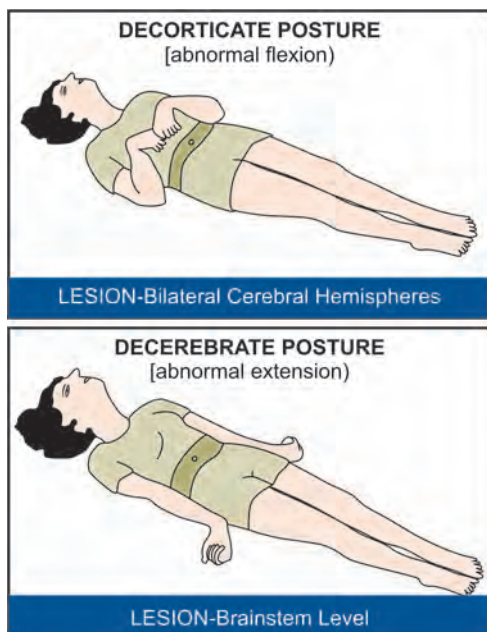

Fig. 8.3: Postures

Postures (Fig. 8.3)

- i. Head and eye deviation to one side and contralateral hemiparesis indicate supratentorial lesion, while ipsilateral hemiparesis indicates brainstem lesion.
- ii. Decerebrate posturing is bilateral extensor posture, with extension of the lower extremities and adduction and internal rotation of the shoulders and extension at the elbows and wrist. Bilateral midbrain or pontine lesions are usually responsible for decerebrate posturing. Less commonly, deep metabolic encephalopathies or bilateral supratentorial lesions involving the motor pathways may produce a similar pattern.
- iii. Decorticate posturing is bilateral flexion at the elbows and wrists, with shoulder adduction and extension of the lower extremities. It is a much poorer localising posture because it may result from lesions in many locations but usually above the brainstem. Decorticate posture is not as ominous a sign as decerebrate posture because the former occurs with many relatively reversible lesions.
- iv. Unilateral decerebrate or decorticate postures are generally less ominous than bilateral posturing. Lesions causing unilateral posturing may be anywhere in the motor system from cortex to brainstem. Unilateral extensor posturing is common immediately after an acute hemispheric event, followed in time by a flexor response.

Adventitious Movements

- i. Tonic-clonic or other stereotyped movements signal seizure as the probable cause of decreased alertness.
- ii. Myoclonic jerking, nonrhythmic jerking movements in single or multiple muscle groups, is seen with anoxic encephalopathy or other metabolic comas, such as hepatic encephalopathy.
- iii. Rhythmic myoclonus, which must be differentiated from epileptic movements, is usually a sign of brainstem injury.
- iv. Tetany occurs with hypocalcaemia.
- v. Cerebellar fits, resulting from intermittent tonsillar herniation, are characterised by a deterioration of level of arousal, opisthotonos, respiratory rate slowing and irregularity, and pupillary dilation.

Differentiating Features between Structural and Metabolic Coma

1. **State of consciousness:** Patients with metabolic problems often have mild alterations in arousal and tend to have waxing and waning of the behavioural state. Patients with acute structural lesions tend to stay at the same level of arousal or progressively deteriorate. Toxins may also cause progressive decline in level of arousal.
2. **Respiration:** Deep, frequent respiration is most commonly due to metabolic abnormalities, but rarely it is caused by pontine lesions or by neurogenic pulmonary oedema secondary to acute structural lesions.
3. **Funduscopy examination:** Subhyaloid haemorrhage or papilloedema is almost pathognomonic of structural lesions. Papilloedema due to increased ICP may indicate an intracranial mass lesion or hypertensive encephalopathy. Papilloedema does not occur in metabolic diseases, except hypoparathyroidism, lead intoxication, and malignant hypertension.
4. **Pupil size:** The pupils are usually symmetrical in coma from toxic-metabolic causes. Patients with metabolic or toxic encephalopathies often have small pupils with preserved reactivity. Exceptions occur with methyl alcohol poisoning, which may produce dilated and unreactive pupils, or late in the course of toxic or metabolic coma if hypoxia or other permanent brain damage has occurred. In terminal asphyxia, the pupils dilate initially and then become fixed at midposition within 30 minutes. The initial dilation is attributed to massive sympathetic discharge.
5. **Pupil reactivity:** Assessment of the pupillary reflex is one of the most useful means of differentiating



metabolic from structural causes of coma. Pupillary reactivity is relatively resistant to metabolic insult and is usually spared in coma from drug intoxication or metabolic causes, even when other brainstem reflexes are absent. Hypothermia may fix pupils, as does severe barbiturate intoxication; neuromuscular blocking agents produce mid-position or small pupils, and glutethimide and atropine dilate them.

6. **Ocular motility:** Dysconjugate eye movements are typically a feature of structural lesions.
7. **Spontaneous eye movements:** Roving eye movements with full excursion most often suggest metabolic or toxic abnormalities.
8. **Reflex eye movements:** Reflex eye movements are normally intact in toxic-metabolic coma, except rarely in phenobarbital or phenytoin intoxication or deep metabolic coma from other causes.
9. **Adventitious movement:** Coma punctuated by periods of motor restlessness, tremors, or spasm is often due to toxins or drugs, such as chlorpromazine or lithium. Brainstem herniation or intermittent CNS ischaemia may also produce unusual posturing movements. Myoclonic jerking is generally metabolic and often anoxic in origin.
10. **Muscle tone:** Muscle tone is usually symmetrical and normal or decreased in metabolic coma. Structural lesions cause asymmetrical muscle tone. Tone may be increased, normal, or decreased by structural lesions.

Appearance and Behaviour

This can be assessed as the patient walks into the consulting room. A note is made of the way the patient carries himself including the way he has attired himself and his personal hygiene. Note also from his behaviour whether he is disturbed, apathetic, agitated or confused.

Emotional State

Assess whether the patient is elated, euphoric, excited or depressed.

Mood: It is the prevailing emotional state.

Affect: It is an emotional experience evoked by a particular stimulus.

Mood is characterised by a feeling of cheerfulness and happiness, a state of exceptional mental well-being or a feeling of depression.

Depression: This is a mood of dejection and gloom for no reason. Depression may be of two types:

1. Major depressive disorder (single or recurrent episodes)
2. Dysthymic disorder (chronic, less intense form of depression lasting for at least two years).

Emotional instability: Inappropriate elation and depression for no reason; It is seen in pseudobulbar palsy.

Mania: It is a distinct period of abnormal and persistently elevated or irritable mood.

Anxiety: It is an anticipatory reaction. It may present with somatic symptoms related to autonomic nervous system or psychic symptoms or both.

Orientation

Questions are put to the patient to test his orientation to time, place and person as follows:

Time	Ask the patient to tell the year, season, date, day and month.
Place	Ask for the state, country, town, hospital and floor in which he is admitted.
Person	Ask for the identity of his nearby relatives or neighbours.
Self	Ask the patient's name, age, address and qualifications.

Rule out *confabulation*, which is a filling in of forgotten memories by inappropriately recalled material from previous experience, e.g. Korsakoff's psychosis.

Handedness

It is the preference to use the hand of a particular side (right or left) for complicated, fine and skillful motor acts.

Dominant hand is the hand used for combing the hair or buttoning the shirt or picking up a coin. It can also be tested indirectly by asking the patient to kick a ball or to use his or her eye to see through a small hole. The leg or the eye used preferentially, gives a clue to the side of cerebral dominance.

On asking the patient to fold his arms across the chest, the dominant arm is placed anteriorly. Similarly, while asking the patient to stand at ease, the dominant hand comes posteriorly.

There is an anatomic difference between the sizes of dominant and nondominant cerebral hemispheres. 'Planum temporale', which is adjacent to the auditory centre of Heschl's transverse gyrus, is larger in the left hemisphere in the right handed individuals. Left handedness may be hereditary or may result from disease of the left hemisphere in early life.



Left hemisphere dominance for language occurs in 95% of right handed people. Even in 50% of left handed individuals, left hemisphere is dominant.

General Intelligence

It is necessary to ascertain the patient's general intellectual ability as evidenced by his educational standard and work records before assessing his intelligence.

Intelligence is assessed by testing the following:

- a. *Abstract thinking*: It is tested by asking the patient to explain the meaning of a common proverb.
- b. *Reasoning*: This is tested by asking him to compare objects or by asking him to differentiate between a lie and a mistake. Test his power to appreciate similarities and dissimilarities between two objects, animals, etc.
- c. *Judgement*: It is tested by asking the patient various questions, like what he would do on seeing a house on fire or what he would do when he finds a stamped envelope on the road.
- d. *Attention*: It is tested by asking the patient to do sequential subtraction of 7 from 100 down to zero and by forward and reverse digit spans.
- e. *Calculation*: It is tested by asking the patient to solve simple numerical problems.

Memory

It is the power to retain and recall past experiences.

Components of Memory

Reception
Registration
Retention
Recall.

Types

- a. *Immediate or short-term memory*: It is the memory for events of a few seconds duration. This holds information close to consciousness for a few seconds only.

This is tested by asking the patient to reproduce a string of numerals.

Example:

- Digit span, 7 forwards, 5 backwards
- Spell 'World' backwards.

Immediate memory is impaired in acute confusional syndrome, Wernicke-Korsakoff syndrome and mostly retained in dementia and amnesic syn-

drome. Immediate memory requires sustained attention also.

- b. *Recent memory*: It means recall of information presented within minutes, hours and days. It is tested by asking the patient to recall certain important recent events or current affairs and by asking him to remember three unrelated common objects or a simple address told to him, a few minutes ago.

It is impaired in dementia, acute confusional syndromes and amnesia. This is tested after two minutes and five minutes depending on the degree of amnesia.

- c. *Long-term or Secondary or Remote memory*: It means memory for past events. It can be tested by asking the dates and salient facts of some well known but distant public events or names of political figures or locations of major cities. It incorporates the meaning of information rather than exact words or pictures.

Perceptions

Delusions: These are false beliefs which continue to be held despite evidence to the contrary.

Hallucinations: These are false impressions referred to the organs of special senses in the absence of a stimulus, e.g., temporal lobe epilepsy, alcohol withdrawal, schizophrenia.

Illusions: These are misinterpretations of stimuli.

Obsessions: These are recurrent and persistent thoughts, which intrudes into the patient's mind despite best effort to get rid of them.

Visuospatial Functions

Ask the patient to copy a drawing of a five pointed star or three dimensional box. Constructional apraxia or visuospatial agnosia results in difficulty in drawing the lines required in the correct spatial orientation or position. 'Perseveration' or visual neglect is revealed by this test.

Apraxia

It is a defect in the ability to carry out known acts in the absence of motor weakness, sensory loss or ataxia. Consequently, the apraxic patient is unable to make use of objects, though their use can be recognised and described. It results from damage to the left parietal cortex or to parietal white matter of the left or of both hemispheres, or from disease of the connections between the two hemispheres through the corpus callosum.



It is tested by asking the patient to use objects (lighting a cigar, copying a cube, star, clock) or to carry out or imitate certain movements.

Types of Apraxia

1. Limb kinetic apraxia.
This involves a specific motor disability of one limb, usually an arm, in the absence of gross weakness or ataxia
2. Ideomotor apraxia.
This refers to the condition in which patient is unable to carry out the motor command, despite adequate comprehension of the command and adequate motor and sensory functions to perform the commands. This is the most frequent type of apraxia. Here the concept is normal, but execution is defective.
3. Ideational apraxia.
This refers to the condition in which patients are apraxic because they have lost the ideas (concepts) behind the skilled movements. Here the patient will name and define an object. But not know how to manipulate the object when it is placed in the hand.
4. Buccofacial apraxia.
This refers to the condition in which the patient cannot perform learned skilled movements of the mouth, lips, cheeks, tongue and throat in the absence of motor paralysis of concerned muscles.

Agnosia

Agnosia is defined as failure to recognise known objects in the presence of intact sensory, visual and auditory pathway.

A. Tactile Agnosia

Patient is not able to recognise known objects in the presence of intact sensory system and he/she should have sufficient motor function and coordination to explore the object.

B. Visual Agnosia

It is the inability to recognize what is seen with the eyes in the presence of intact visual pathway. At the same time, they can describe the colour, size, and shape of the object without recognising it.

C. Prosopagnosia

It is the inability to identify a familiar face which occurs in parieto-occipital lesion.

D. Anosognosia

In right parietal lobe lesion, there is lack of awareness to recognize the paralysed limb.

Sleep

Sleep is an elemental phenomenon of life and an indispensable phase of human existence. Sleep represents one of basic 24-hour circadian rhythms.

Most adults sleep for 7 to 8 hours/day.

Age	Duration of sleep
Newborn	16–20 hours
Child	10–12 hours
10 years	9–10 hours
Adolescence and adults	7–8 hours
Late adult life	About 6.5 hours

Types of Agnosia

Modality	Subtypes	Neuroanatomical correlates
Vision	Visual object agnosia	Bilateral occipitotemporal
	Associative prosopagnosia	Left occipitotemporal
	Apperceptive prosopagnosia	Bilateral occipitotemporal Right occipitotemporal and occipitoparietal
Audition	Environmental sound agnosia	Bilateral posterior superior Temporal
	Phonagnosia	Right inferior parietal
	Amusia	Right posterior temporal and inferior parietal
Somatosensory	Tactile object agnosia (complete)	Right and left parietal operculum, posterior insula
	Tactile object agnosia (nonmanipulable stimuli)	Right superior mesial parietal
Perception of disease	Anosognosia	Right parietal and bilateral ventromedial frontal



States and Stages of Sleep

It comprises of 2 distinct physiological states namely REM and Non-REM sleep.

1. REM (Rapid eye movement sleep/dreaming/desynchronised/D-sleep)
2. Non-REM Sleep (orthodox/synchronised/S-sleep).

Non-REM sleep has 4 stages, two of which are known as 'slow-wave' or deep sleep because they are associated with low frequency synchronised waves on EEG.

Stage 1: Transition from wakefulness is characterised by disappearance of regular α pattern and emergence of a low amplitude mixed frequency pattern the theta range (2–7 Hz). It is associated with slow rolling eye movements.

Stage 2: There is occurrence of K complexes and sleep spindles superimposed upon a background activity similar to that of stage 1 (low amplitude).

Stage 3: There is predominance of delta EEG activity in 20 to 50% of the record (increased amplitude and decreased frequency).

Stage 4: More than 50% of the record is dominated by delta EEG activity.

Types of waves in EEG	Rate
α	7–13/sec
β	> 13/sec
θ	4–6/sec
δ	< 4/sec

REM Sleep

This comprises of low amplitude, mixed frequency waves.

REM sleep develops after progression through various stages of NREM sleep, usually within 90 minutes. It is the stage in which most dreaming occurs. During a night's sleep, there is a cycle of Non-REM and REM sleep with episodes of REM becoming relatively longer.

Tonic muscle activity is minimal during REM sleep. Eye movements are rapid and conjugate in all directions. Gross body movements occur every 15 minutes or so in all stages of sleep, but are maximal in the transition between REM and NREM sleep.

REM sleep has phasic and tonic components. During the phasic period in addition to eye movements, the pupils dilate and constrict alternately and BP, pulse, and respiration increase and may become irregular. During the nonphasic period there is flaccidity, atonia of upper airways, intercostal muscles and abdomen

which may pose a threat to life in infants with excessive respiratory difficulty and in patients with kyphoscoliosis, muscular dystrophy, and paralytic poliomyelitis.

About 20 to 25% of total sleep time in young adults is spent in REM sleep, 3 to 5% in stage 1, 50 to 60% in stage 2 and 10 to 20% in stage 3 and 4 combined. Stage 3 and stage 4 sleep decreases with age and in elderly over 70 years, there is no stage 4 sleep virtually.

Most adults sleep 7–8 hours/night usually. At the extremes of age, infants and the elderly have frequent interruptions of sleep.

Adults with habitual sleep durations of less than 4 hours or greater than 9 hours have increased mortality rates as compared to those who sleep for 7–8 hr/night.

Rapid onset of REM sleep in adults may suggest:

- Endogenous depression
- Narcolepsy
- Circadian rhythm disorders
- Drug withdrawal.

During sleep there is:

- a. Fall in body temperature, mainly during NREM period
- b. During REM sleep, glucose metabolism is increased in comparison with the waking state
- c. In urine, absolute sodium and potassium excretion decreases
- d. Secretion of cortisol and TSH are decreased at the onset of sleep. Cortisol secretion increases at awakening
- e. Melatonin (from pineal gland) is secreted at night and ceases upon retinal stimulation by sunlight
- f. During stages 3 and 4, growth hormone is secreted till middle and late adult life
- g. Prolactin secretion increases at night in both men and women
- h. Sleep associated secretion of LH occurs in pubertal boys and girls.

Physiologic mechanism governing NREM and REM sleep lie in the pontine reticular formation.

Neuroanatomy of Sleep (Sleep Centre)

Generation of sleep is from medullary reticular formation, the thalamus and basal forebrain. Generation of wakefulness or EEG arousal is maintained by brainstem reticular formation, the midbrain, the subthalamus, the thalamus and the basal forebrain. Current hypothesis suggests that the capacity for sleep and wake generation is distributed along an axial 'core'



of neurons extending from the brainstem rostrally to the basal forebrain. There is no specific sleep centre.

Function of Sleep

Sleep is thought to be useful for body restitution, facilitation of motor function and for consolidation of learning and memory.

Effect of Sleep Deprivation

Deprivation of sleep (REM, NREM) for about 60–200 hours causes increased sleepiness, fatigue, irritability and difficulty to concentrate. Performance of skilled motor activity decreases. Self care is neglected. Later, stages of microsleep occurs leading to all types of errors and accidents. Illusions, hallucinations (visual and tactile) may occur.

Patient may have nystagmus, impairment of saccades, loss of accommodation, slight tremor of hands, ptosis, expressionless face, thickness of speech, mispronunciation, etc. Seizure threshold is reduced. Concentration of 17-OH corticosteroids increases and catecholamine output rises. Rarely, psychotic episodes of screaming and sobbing may occur. During recovery, patients go straight into stage IV NREM at the expense of stage II and REM sleep. The next day, REM sleep occurs with a longer duration.

International Classification of Sleep Disorders

Dyssomnias

Intrinsic Sleep Disorders

1. Psychophysiologic insomnia
2. Idiopathic insomnia
3. Narcolepsy
4. Recurrent or idiopathic hypersomnia
5. Post-traumatic hypersomnia
6. Sleep apnoea syndromes
7. Periodic limb movement disorder
8. Restless leg syndrome.

Extrinsic Sleep Disorders

1. Inadequate sleep hygiene
2. Environment sleep disorders
3. Altitude insomnia
4. Adjustment sleep disorders
5. Sleep onset association disorders
6. Food allergy insomnia
7. Nocturnal eating/drinking syndrome
8. Drug/alcohol dependent sleep disorders.

Circadian Rhythm Sleep Disorders

1. Time-Zone changes (jet lag) syndrome
2. Shift work sleep disorder
3. Delayed sleep phase syndrome (patient goes to bed late (2–3 am) and gets up late (11 am))
4. Advanced sleep phase syndrome (patient goes to bed early (8–9 pm) and gets up early (4–5 am))
5. Non-24 hours sleep wake disorders.

Parasomnias

Arousal Disorders

1. Confusional arousal
2. Sleep walking
3. Sleep terrors.

Sleep Wake Transition Disorders

1. Rhythmic movement disorders
2. Sleep talking
3. Nocturnal leg cramps.

Parasomnias Associated with REM Sleep

1. Nightmares
2. Sleep paralysis
3. Impaired sleep related penile erection
4. Sleep related painful erection
5. REM sleep related arrhythmias
6. REM sleep behaviour disorders.

Others

1. Sleep bruxism
2. Sleep enuresis
3. Nocturnal paroxysmal dystonia.

Sleep Disorders Associated with Medical or Psychiatric Disorders

Associated with Mental Disorders

Schizophrenia, anxiety, affective illness, obsessive-compulsive neurosis, chronic alcoholism, depression.

Associated with Neurological Disorders

- a. Cerebral degenerative disorders
- b. Parkinsonism
- c. Fatal familial insomnia
- d. Sleep related epilepsy
- e. Sleep related headaches.

Associated with Other Medical Disorders

1. Sleeping sickness
2. Nocturnal cardiac ischaemia



3. COPD, cystic fibrosis
4. Sleep related asthma
5. Sleep associated gastro-oesophageal reflux, peptic ulcer disease
6. Chronic renal failure, liver failure
7. Hyperthyroidism
8. Drugs (theophylline, adrenergic agonists, glucocorticoids can disrupt sleep)
9. Chronic pain.

Insomnia

It is a complaint of inadequate sleep. It can be

- a. Sleep onset insomnia—difficulty in falling asleep.
- b. Sleep maintenance insomnia (frequent or sustained awakenings).
- c. Non-restorative sleep—persistent sleepiness despite sleep of adequate duration.

Sleep Apnoea Syndromes

There is respiratory dysfunction during sleep. Cough reflex is depressed. There is falling back of tongue or epiglottis. The cessation of breathing may be due to either occlusion of the airway (obstructive sleep apnoea) absence of respiratory effort (central sleep apnoea) or a combination of these (mixed sleep apnoea). These are common in obese men and elderly, often associated with hypertension.

Parasomnias

These are behavioural disorders occurring during sleep that are associated with brief or partial arousals but not without marked sleep interruption. There is no impairment of daytime alertness.

The two most important parasomnias are sleep walking and night terror both of which occur in slow wave sleep.

Somnambulism (Automatic Motor Activities during Sleep)

Patients may walk, urinate inappropriately or exit from the house while remaining unconscious or uncommunicative. Arousal is difficult. It occurs in stages 3 and 4 of NREM sleep. It is common in children and adolescents. Diazepam can be tried in severe cases.

Sleep Terrors (Pavor Nocturnus)

It occurs in young children during first several hours of sleep (stage 3 or 4 of NREM). Child screams with autonomic arousal (sweating, tachycardia, hyperventilation) and usually does not remember the episode.

Nightmares occur during REM sleep and cause full arousal with memory for the dream associated unpleasant episode. It occurs following withdrawal of alcohol or sedatives or may be due to barbiturate intoxication. Autonomic changes are less frequent. As an isolated event they can occur following fever, indigestion, reading blood curdling stories or exposure to terrifying movies.

REM Sleep Behaviour Disorders

It is common in men of middle or old age. There is previous history of GBS, degenerative disorders, dementia, subarachnoid haemorrhage or stroke. Commonly there is injury to the bystander. Upon waking patient reports vivid dreams. It has to be differentiated from nocturnal seizures after a polysomnogram.

One-third of patients will go on to develop Parkinsonism.

Narcolepsy and Cataplexy

There is excessive daytime sleepiness with involuntary daytime sleep episodes, disturbed nocturnal sleep and cataplexy (sudden weakness or loss of muscle tone often elicited by emotion). It consists of a clinical tetrad of

- a. Excessive daytime somnolence
- b. Cataplexy
- c. Hypnagogic hallucinations
- d. Sleep paralysis.

Associated symptoms are automatic behaviour during wakefulness, amnesia lasting for a few seconds to hours, sudden burst of words without meaning or relevance terminating the attack.

The cause of this disorder is unknown. Rarely it may follow cerebral trauma, multiple sclerosis, cranio-pharyngioma, tumours of third ventricle or brainstem and diabetes insipidus.



Treatment

1. Strategically placed 15–20 minute naps
2. Use of stimulant drugs (dextroamphetamine sulphate, methylphenidate, pemoline)
3. Tricyclic antidepressant for the control of cataplexy
4. Modafinil 200–400 mg/day single dose is a novel weight promoting agent for the treatment of excessive daytime somnolence in narcolepsy.

They should be warned of the danger of sleep attacks and analogous lapses of consciousness while driving or during engagement in other activities that require constant alertness.



Sleep Bruxism

This is a involuntary, forceful grinding of teeth during sleep that affects 10–20%. The typical age of onset is 17–20 years. Spontaneous remission may occur by the age of 40 years.

Malocclusion of teeth and central neural mechanisms may be involved in the pathophysiology. Severe cases are treated with rubber tooth guard and stress management should be given.

Sleep Enuresis (Bed Wetting)

This occurs during slow wave sleep in the young. It is normal before 5 or 6 years. The condition improves at puberty and is rare in adulthood.

Primary enuresis: Failure to attain continence since birth.

Secondary enuresis: Patient fully continent for 6 to 12 months and then becomes incontinent. It may be due to

- Emotional disturbances
- UTI
- Cauda equina lesions
- Epilepsy
- Sleep apnoea
- Urinary tract malformations.



Treatment

- Bladder training exercises
- Behavioural therapy
- Stress management
 - Oxybutynin chloride
 - Imipramine
 - Intranasal desmopressin.

Sleep Disorders with Neurologic Disorders

This may be due to

- Pain (cervical spondylosis)
- Dementia (nocturnal wandering, exacerbation of symptoms at night)
- Epilepsy may present during sleep.

Nocturnal epilepsy occurs soon after the onset of sleep or during the 1st hour after awakening, mainly at stage 4 NREM or REM sleep. Deprivation of sleep on prior days may be conducive to a seizure. Sleeping epileptics attract attention to their seizures by cry, violent motor activity or laboured breathing. They fall into a state from which they cannot be aroused. Sometimes, disheveled bed clothes or a few drops of blood on the pillow, urinary incontinence, bitten tongue or sore muscles indicate seizures. Rarely they may die during an attack or due to arrhythmias.

- Movement disorders (Parkinson's disease, hemiballismus, Huntington's chorea, Gilles de La Tourette syndrome—patients have extrapyramidal symptoms and coprolalia) are associated with disturbed sleep.
- Headache syndromes may show sleep associated exacerbations (migraine, cluster headache).
- Fatal familial insomnia:* It is a hereditary disorder. There is bilateral degeneration of anterior and dorsomedial nuclei of the thalamus. Later autonomic dysfunction, dysarthria, myoclonus, coma and death may occur.

Circadian Rhythm Sleep Disorders

These are disorders of sleep timing rather than sleep generation.

It can be organic if the defect is in the circadian pacemaker or it can be environmental.

Jet-Lag Syndrome

It is associated with excessive daytime sleepiness, sleep onset insomnias, frequent arousals or GI discomfort; it occurs up to 2–14 days depending on the number of time zones crossed, the direction of travel, age and phase shifting capacity of the traveller. Those who spend a lot of time outdoors can adapt quickly. East bound travellers fall asleep late and face an early sunrise. West bound travellers face late sunset, a long night sleep and adapt early.

Shift-Work Sleep Disorders

Sleep deprivation and misalignment of circadian phase produce decreased alertness and performance and cause increased safety hazards among night shift workers. There is improvement if the following criteria are followed.

- Work schedule should favour a clockwise rotation of shift.
- Minimise the frequency of shift rotation (Alteration in shift timings should be done every 2–3 weeks).
- Consecutive night work days should be restricted to 4–5 days only per week.

Speech and Language

Definitions

Aphasia: Disturbance in the comprehension or production of language in written or spoken forms.

Dysphasia: It means difficulty in speech. The disorder is usually incomplete.

Language: This refers to the selection and serial ordering of words according to learned rules by which a person can use spoken or written modalities to communicate with others and to express cerebral activities involved with thinking and learning.

Anarthria: Total loss of articulation.

Dysarthria: Difficulty in articulation usually related to poor pronunciation of consonants.

Agraphia: Inability to write.

Dysgraphia: Faulty writing skills due to disturbances of motor skills in writing.

Alexia: Inability to read.

Dyslexia: Difficulty in reading.

Word deafness: It means difficulty in understanding the meaning of words heard.

Word blindness: It means difficulty in understanding the meaning of words seen.

Paraphasia: Simple syllabic or word elements are missing and are replaced by substitutions so that desired response is only approximated.

Paraphasia may be

- Literal incorrect letters (Grass is greel)
- Verbal incorrect words (Grass is blue)
- Neologisms nonsense words (Grass is grumps).

Aphonia: Total loss of production of voice.

Dysphonia: This means difficulty in phonation (voice). It is due to disease of larynx or its innervation causing inability to produce basic vowel sounds, often with reduced voice volume.

Bradylalia: Slowness of speech, e.g. depression, hypothyroidism, parkinsonism.

Echolalia: This means repetition of examiner's words by the patient, due to cortical or temporoparietal lesions or schizophrenia.

Palilalia: This means repetition of terminal words of own speech, e.g. parkinsonism, diffuse cortical lesions.

Speech Areas (Fig. 8.4)

Broca's area (motor speech area/area 44): It is the posterior most portion of inferior third frontal convolution of the dominant hemisphere. It is important for fluency, rhythm of speech and for the maintenance of grammar and syntax.

Broca's aphasia (expressive aphasia or motor aphasia): Damage to motor area results in poorly articulated and

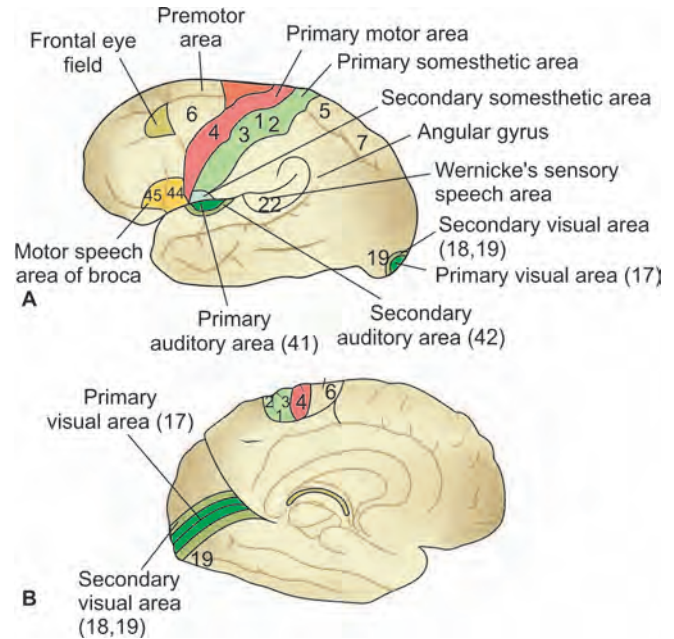

Figs 8.4A and B: Functional areas of cerebral cortex

non-fluent speech, with reduced number of words, with errors of grammar and syntax.

Wernicke's area (sensory speech area/posterior part of area 22 and parietotemporal junction): It is the dominant tempero parieto-occipital region and is important in the comprehension of received speech and in the selection of words to express ideas.

Wernicke's aphasia (receptive aphasia or sensory aphasia): With damage to sensory area, the output of spontaneous speech may be normal or increased, the speech is fluent and the articulation of phonemes is usually intact. Speech may contain paraphasias, neologisms, jargons. When lesion is restricted to temporal region, there is disturbance in words heard. When lesion is restricted to parieto-occipital region, there is disturbance in words seen.

Conduction aphasia: The defect is inability of the patient to repeat phrases or words spoken by the examiner (*impaired repetition*). The lesion lies in the perisylvian area with damage to the fibres of arcuate fasciculus.

Transcortical aphasia

Motor Anterosuperior to Broca's area

Sensory Posteroinferior to Wernicke's area

The speech disturbance in these two conditions will be of Broca's and Wernicke's type aphasias respectively with *normal repetition*.



Differentiating Features of Various Speech Syndromes

Syndromes	Clinical Features	Site of Lesion	Causes	Associated Features
Global aphasia	Minimal speech; nonfluent; comprehension for spoken and written language—poor	Internal carotid and middle cerebral arteries (dominant frontal, parietal, superior temporal lobe)	Infarction, trauma, tumour	Contralateral hemiplegia, hemisensory loss, hemianopsia
Broca's aphasia	Nonfluent; agrammatic; dysprosodic; may be mute	Superior frontal branch of MCA	Haemorrhage, tumour, infarction.	Contralateral hemiplegia, minimal sensory loss, oral dyspraxia, cortical dysarthria, impairment in writing
Wernicke's aphasia	Fluent speech; incomprehension; no repetition; alexia; agraphia; paraphasias	Lower division of MCA	Haemorrhage, tumour, herpes simplex encephalitis	Parietal lobe sensory deficit, hemianopsia; no motor disturbance
Conduction aphasia	Paraphasia; difficulty in repetition and in reading aloud. Comprehension normal	Posterior branch of MCA (upper bank of sylvian fissure, inferior parietal lobule)	Embolism	Contralateral hemihypesthesia, homonymous hemianopsia, optokinetic nystagmus
Pure word deafness (mainly auditory)	Impaired auditory comprehension; inability to repeat words or write a dictation	Superior temporal gyrus	Infarction, abscess, tumour	Rarely deafness
Dyslexia with dysgraphia (mainly visual)	Impaired visual comprehension; cannot read or write	Parieto-occipital region	Infarction, tumour, lobar haemorrhage	Hemianopsia
Pure word blindness	Normal spoken language and writing; inability to read	Posterior cerebral artery (left occipitostriate cortex, adjacent association cortex, posterior corpus callosum)	Infarction, tumour, lobar haemorrhage	Hemianopsia
Isolation of speech areas	Parrot like speech (echolalia)	Watershed zones between ACA, MCA and PCA territories	Hypotension, hypoxia, cardiac arrest	Decreased alertness & responsiveness; bilateral leg weakness
Amnesic-dysnomic aphasia	Inability in recalling names of objects or parts of objects; difficulty in recent memory	PCA territory (deep temporal lobe, parahippocampal or hippocampal gyrus)	Tumour, Alzheimer's disease, infarction of PCA, herpes simplex encephalitis	Apraxia; dementia; no motor or sensory loss; upper quadrantic field defects

Global aphasia: In this condition, there are marked elements of both anterior (Broca) and posterior (Wernicke) aphasias. This is due to large lesions in the middle cerebral artery territory or left internal carotid artery or a large haemorrhage or a major tumour or trauma (Fig. 8.5).

Dysarthria

Cerebellar dysarthria: Patient speaks slowly and deliberately, syllable by syllable as if scanning a line of poetry and the normal prosodic rhythm is lost (scanning speech). When the speech has explosive character and slurring of consonants it is called staccato speech.

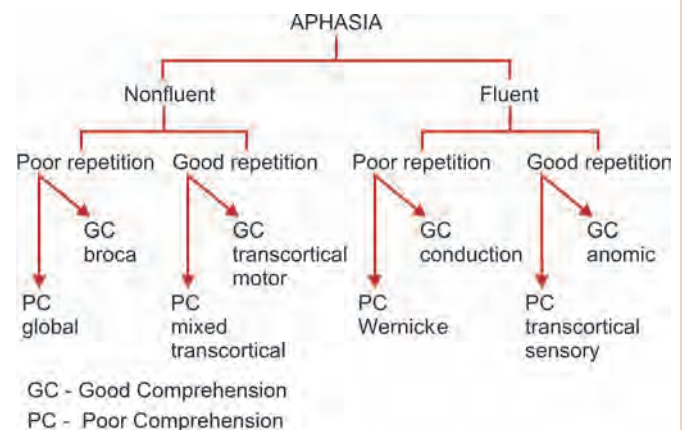

Fig. 8.5: Algorithm for approach to aphasia



Pseudo-bulbar (spastic) dysarthria: Individual syllables are slurred and the precision of consonant pronunciation is lost. It is due to lesions in corticospinal fibres supplying muscles of face, larynx, tongue and respiration (multiple lacunar infarcts, motor neuron disease and atherosclerosis), e.g. British constitution becomes Brizh conshishusion.

Bulbar dysarthria: Lower motor neuron bulbar palsy affect the muscles of articulation. There is non-specific slurring of speech. Other features like dysphagia and nasal regurgitation are present, e.g. motor neuron disease.

Rigid dysarthria: This is due to extrapyramidal involvement, e.g. low volume, monotonous speech of parkinsonism.

Cortical dysarthria: There is irregular hesitancy in word production associated with difficulties in abstract, volitional movements of the lips and tongue (Orofacial apraxia). It is usually associated with aphasia. The lesion is in the left frontal and temporal regions. It never occurs as an isolated defect.

Peripheral Disorders

This can be due to the involvement of the following:

1. Neuromuscular—myasthenia gravis
2. Muscular—myopathy (oculopharyngeal)
3. Structural—cleft lip, cleft palate, dentures.

Examination of Speech and Language

1. Spontaneous speech
 - Articulation
 - Fluency
 - Paraphasias
 - Grammar
 - Syntax
2. Naming objects, concepts
3. Comprehension of spoken commands
4. Repetition of spoken phrases
5. Reading aloud
6. Handwriting.

Lobar Functions

Functions of Left Hemisphere

- a. Verbal
- b. Linguistic description
- c. Mathematical
- d. Sequential
- e. Analytical
- f. Direct link to consciousness.

Functions of Right Hemisphere

- a. Almost non-verbal
- b. Musical
- c. Geometrical
- d. Spatial comprehension
- e. Temporal synthesis
- f. Doubtful link to consciousness.

Frontal Lobe Functions

Personality
Emotional response
Social behaviour.

Frontal Lobe Lesions

Effects of Unilateral Frontal Lobe Disease Either Left or Right

- a. Contralateral spastic hemiplegia.
- b. In prefrontal lesions, no hemiplegia; grasp and suck reflexes may be released. There is slight elevation of mood, increased talkativeness and tendency to joke (disinhibition), loss of initiative, lack of tact.
- c. Anosmia with involvement of orbital parts.
- d. Impaired memory.

Effects of Nondominant Right Frontal Lobe Disease

Same features as mentioned above.

Effects of Dominant Left Frontal Lobe Disease

In addition to the above features,

- a. Motor speech disorder with agraphia with or without apraxia of the lips and tongue
- b. Loss of verbal associative fluency; perseveration
- c. Sympathetic apraxia of left hand.

Effects of Bilateral Frontal Lobe Disease

- a. Bilateral hemiplegia
- b. Pseudo-bulbar palsy
- c. In prefrontal lesions, abulia or akinetic mutism, lack of ability to solve problems, lack of attention, rigidity of thinking, bland affect, labile mood, and varying combination of grasping, sucking, decomposition of gait, and sphincteric incontinence.

Functions of Parietal Lobe

Dominant side

Calculation
Language
Planned movement
Appreciation of size, shape, weight and texture.



Nondominant side

- Spatial orientation
- Constructional skills.

Parietal Lobe Lesions

Effects of Unilateral Parietal Lobe Disease Either Left or Right

- a. Cortical sensory loss and sensory extinction
- b. Mild hemiparesis, unilateral muscular atrophy in children
- c. Homonymous inferior quadrantanopia (incongruent), visual inattention, anosognosia, neglect of one half of body
- d. Abolition of optokinetic nystagmus to one side.

Effects of Dominant Left Parietal Lobe Disease

In addition to the above features, patients have

- a. Disorders of language (alexia)
- b. Gerstmann syndrome (defect in calculation, writing, finger naming and right to left orientation)
- c. Tactile agnosia
- d. Bilateral ideomotor and ideational apraxia.

Effects of Nondominant Right Parietal Lobe Disease

- a. Visuospatial disorders
- b. Topographic memory loss
- c. Anosognosia and dressing apraxia
- d. Construction apraxia.

Effects of Bilateral Parietal Lobe Disease

- a. Visuospatial imperception
- b. Optic ataxia
- c. Spatial disorientation
- d. Severe forms of construction apraxia.

Functions of Temporal Lobe

Dominant

Auditory perception, speech, language, verbal memory and olfaction.

Nondominant

Auditory perception
 Music tone sequences
 Non-verbal memory (faces, shapes, music)
 Olfaction.

Lesions of Temporal Lobe

Effects of Unilateral Temporal Lobe Disease Either Left or Right

- a. Auditory, visual, olfactory and gustatory hallucinations

- b. Dreamy states with uncinat seizures
- c. Homonymous superior quadrantanopia
- d. Emotional and behavioural changes.

Effects of Dominant Left Temporal Lobe Disease

In addition to the above features—

- a. Wernicke's aphasia
- b. Amusia
- c. Impairment in tests of verbal material presented through the auditory sense
- d. Dysnomia or amnesic aphasia.

Effects of Nondominant Right Temporal Lobe Disease

In addition to the above features—

- a. Inability to judge spatial relationships in some cases
- b. Impairment in tests of visually presented non-verbal material (non-verbal memory)
- c. Agnosia for sounds and some qualities of music.

Effects of Bilateral Temporal Lobe Disease

- a. Korsakoff's amnesic effect
 - b. Apathy and placidity
 - c. Increased sexual activity
 - d. Sham rage
- b, c and d—Kluver-Bucy syndrome.

Functions of Occipital Lobe

Analysis of vision.

Lesions of Occipital Lobe

Effects of Unilateral Disease, Either Right or Left

- a. Contralateral (congruent) homonymous hemianopia, which may be central (splitting the macula) or peripheral; also homonymous hemiachromatopsia
- b. Irritative lesions—elementary hallucinations.

Effects of Left Occipital Lobe Disease

In addition to the above features—

- a. Splenium of corpus callosum—alexia, colour anomia
- b. Object agnosia.

Effects of Right Occipital Lobe Disease

In addition to the above features—

- a. In extensive lesions, visual illusions, hallucinations
- b. Loss of topographic memory and visual orientation.

Effects of Bilateral Occipital Lobe Disease

- a. Cortical blindness (pupils reactive)
- b. Anton's syndrome (denial of blindness in patients who cannot see)



- c. Loss of perception of colour
- d. Prosopagnosia (inability to identify a familiar face), simultanagnosia (a cognitive defect in the synthesis of visual impressions leading to lack of ability to read all but, the shortest words spelled out letter by letter; there is a quantitative defect in the capacity for perceptual analysis and form synthesis, resulting in decrease in the span of visual form apprehension)
- e. Balint's syndrome (inability to look voluntarily into and to scan the peripheral field despite full eye movements; failure to precisely grasp or touch an object under vision; visual inattention mainly affecting the peripheral field).

Cognitive Scales

Cognitive function is assessed by

1. Mini mental state examination

Orientation: 1 point for each correct answer

What is the: (orientation to time)

- time
- date
- day
- month
- year 5 points

What is the name of this: (orientation to place)

- ward
- hospital
- district
- town
- country 5 points

Registration

Name three objects

Score 1, 2, 3 points according to how many are repeated

Re-submit the list until the patient is word perfect in order to use this for a later test of recall

Score only for first attempt 3 points

Attention and calculation

Have the patient subtract 7 from 100 and then from the result a total of five times.

Score 1 point for each correct subtraction 5 points

Recall

Ask for three objects used in the registration test, one point being awarded for each correct answer

3 points

Language

1 point each for two objects correctly named (pencil and watch) 2 points

1 point for correct repetition (No ifs and buts) 1 point

3 points if three-stage commands correctly obeyed 'Take this piece of paper in your right hand, fold it in half, and place it on the floor'. 3 points

1 point for correct response to a written command such as 'close your eyes'. 1 point

Have the patient write a sentence. Award 1 point if the sentence is meaningful, has a verb and a subject. 1 point

Test the patient's ability to copy a complex diagram of two intersected pentagons. 1 point

Total score is 30. Maximum score of 30 is normal.

Scores between 15 and 22 suggest mild to moderate dementia.

Scores lower than 21 are associated with severe cognitive impairment.

2. Mental status questionnaire (MSQ)

1. What is the name of this place (where are we now)?

2. What is the address of this place?

3. What is the date?

4. What month is it?

5. What year is it?

6. How old are you?

7. When is your birthday?

8. What year were you born?

9. Who is the Prime Minister?

10. Who was the previous Prime Minister?

Total score 10 (1 for correct response, 0 for incorrect response)

Normal subjects score 9 or 10; scores less than 8 imply a degree of mental confusion.

Examination of the Cranial Nerves (Fig. 8.6)

First Cranial Nerve (Olfactory Nerve)

Olfactory nerve subserves the sense of smell.

Anatomical Peculiarity

This is the only sensory pathway having no thalamic connection (Fig. 8.7).

Testing Sense of Smell

1. It is tested separately in each nostril, after confirming the patency of the nostrils, and with the eyes closed.
2. Substances with familiar odours like coffee, peppermint oil, clove oil, soap, etc. can be used. Irritating and pungent substances like ammonia are avoided as trigeminal nerve is also stimulated.

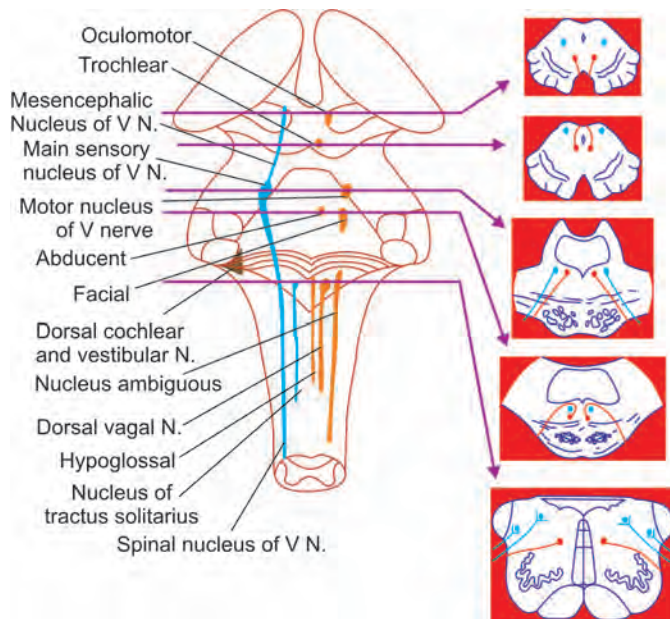

Fig. 8.6: Cranial nerve nuclei

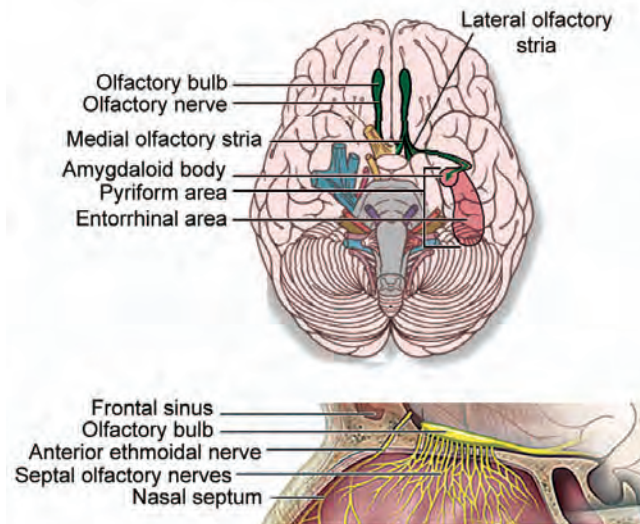

Fig. 8.7: Anatomy of the olfactory nerve

3. There is a strong relationship between the sense of smell and taste, which combine to give a perception of flavour. Normal olfaction is therefore necessary to appreciate taste.

Interpretation

Loss of Sense of Smell (Anosmia)

1. This most commonly occurs due to nasal diseases like catarrh, sinusitis, hay fever

2. Head injuries may result in shearing strain and tear of olfactory filaments. This is the most common neurological cause of anosmia
3. Tumours of the anterior cranial fossa from frontal lobe
4. Chronic basal meningitis (tuberculous, syphilitic or neoplasm)
5. Kallman's syndrome (anosmia, obesity, hypogonadism, midline defects)
6. Tabes dorsalis
7. Internal hydrocephalus
8. Ageing
9. Alzheimer's disease
10. Parkinson's disease
11. Huntington's chorea
12. Down syndrome.

Unilateral Anosmia is a useful sign of anteriorly situated space occupying lesion like sub-frontal meningioma or frontal lobe tumour.

Increased Olfactory Acuity (Hyperosmia)

1. It is occasionally a feature of premonitory phase of migraine
2. Addison's disease
3. Hyperemesis gravidarum
4. Mucoviscidosis
5. Strychnine poisoning.

Perversion of Smell (Parosmia)

1. It is seen during partial recovery, from traumatic anosmia
2. Severe nasal infection
3. Ingestion of drugs (phenytoin)
4. Psychological.

Foul Smell (Cacosmia)

This is said to be present when the patient perceives unpleasant odours in the absence of a stimuli. It is seen in severe upper respiratory tract infections and in atrophic rhinitis.

Olfactory Hallucinations

They are usually of unpleasant nature and characteristic of epilepsy arising in the uncinate gyrus of temporal lobe. They may also occur in psychosis.

Second Cranial Nerve (Optic Nerve)

This nerve subserves the sense of vision.

Examination of this nerve consists of testing of

1. Visual acuity

Some Common Features of Olfaction and Taste Sensations

Olfaction	Taste
1. The olfactory fibres do not relay in the thalamus	Only a part of the taste fibres relay in the thalamus
2. Bacterial and viral infections (URI) can cause loss of olfaction	Bacterial colonisation of the taste pores leads to loss of taste sensation
3. Toxins (toxic chemicals), drugs that affect cell turnover and irradiation all affect olfaction	Toxins (heavy metals), drugs that affect cell turnover and irradiation all affect taste sensation
4. Abnormalities of mucous secretion in which the olfactory cilia are bathed can result in decreased olfaction	Abnormalities of the salivary milieu in which the taste receptors are bathed can lead to loss of taste sensation
5. Zinc and vitamin therapy may improve olfaction	Zinc and vitamin therapy may improve taste sensation

2. Visual fields
3. Colour vision
4. Pupillary responses
5. Inspection of optic nerve head and fundus by ophthalmoscopy.

Testing of Visual Acuity

It is a measurement of the efficacy of the macular or central vision and depends on the intactness of this part of the retina and its nervous connection. Peripheral retinal lesions do not significantly affect visual acuity.

This is done for both near and distant vision. Standard *Snellen's type chart* is used for testing distant vision. Each eye is tested separately at a distance of six metres. Acuity is recorded as a fraction. Normal visual acuity is 6/6. Corrected visual acuity of 6/60 bilaterally constitutes legal blindness. If visual acuity is severely depressed, finger counting, hand movement and perception of light should be tested (Fig. 8.8).

Jaeger type card held at a distance of one foot from patient's eye is used for testing near vision of each eye.



Causes of Decreased Visual Acuity

1. Papillitis
2. Retrobulbar neuritis
3. Refractive errors
 - a. Myopia
 - b. Presbyopia
 - c. Astigmatism
4. Primary ocular disorders



Fig. 8.8: Snellen's chart

- a. Iridocyclitis
- b. Corneal opacities
- c. Cataracts
- d. Vitreous opacities
- e. Retinal detachment
- f. Glaucoma.

Loss of visual acuity is commonly due to refractive errors of the eye, cataracts, vitreous and corneal opacities.

Pin hole test: It is useful in detecting whether poor vision is due to refractory error or disease of the eyeball or visual pathway. If patient is able to see better through a pin hole then patient most probably has refractory error.

Visual acuity is not affected in lesions posterior to optic chiasma except in cortical blindness.

Testing of Visual Fields

The full extent of vision observed while visualising an object is known as the visual field. The field of vision is limited by the area of the retina and by the margins of the orbit, nose and cheek.

Normal visual field using 5 mm white object is approximately 100° temporally, 60° nasally, 60° superiorly and 75° inferiorly.

Concentric contraction of the visual fields binocularly to less than 10° constitutes legal blindness.



Fig. 8.9: Confrontation method

Confrontation method: This method is useful for testing peripheral field of vision (Fig. 8.9).

The examiner must have a normal visual field, as field defects present in the patient is detected by comparing his field of vision with that of the examiner. The examiner is seated at a distance of one metre from the patient. Both eyes are tested simultaneously first and then each eye separately. The test is carried out by asking the patient to fix his gaze on the examiner's eye (patient's right eye is fixed on the examiner's left eye and vice versa). The eye not being tested, is covered. The patient is instructed not to move his head or shift his gaze. The examiner then moves his finger, kept midway between him and patient from the periphery to the centre in the temporal, nasal, superior and inferior directions.

By this method, approximate defects in the visual fields can be made out.

Red pin test: This outlines the central field by using a red hat-pin. The test is carried out as in the confrontation method. Central area of impaired vision (central scotoma) can be detected by this method. This test also determines the size of the physiological blind spot.

A red hat-pin is used for testing the central field of vision as the macula, which is the area for perceiving the central field of vision, contains a large number of cones, which in turn perceive coloured objects (especially red) better than white.

Perimetry: This surveys the monocular field of vision, e.g. Goldmann perimeter used to chart patient's visual field on Bjerrum's screen. It is the most accurate method for testing the field of vision.

Automated perimetry: Automated perimetry utilises computer to programme visual field sequences.

They provide exact repeatable tests through a selection of visual field testing procedure. They are more sensitive than manual perimetry and always reproducible.

Changes in the Field of Vision (Fig. 8.10)

1. Central scotoma

It is the loss of vision confined to central field of vision. Unilateral central scotoma is commonly due to demyelination of the optic nerve (multiple sclerosis) and diseases of the choroid or retina and bilateral scotoma is due to toxic causes like alcoholism, vitamin B₁₂ deficiency.

2. Hemianopia

It is the loss of sight in one half of the visual field.

a. *Homonymous hemianopia:* It is the loss of nasal field of vision in one eye and temporal field of vision in the other eye.

b. *Heteronymous hemianopia:* It is the loss of either the nasal or the temporal field of vision in both eyes.

c. *Incongruous hemianopia:* The outline of visual field loss in both eyes are different, e.g. lesions of optic tract, or chiasma (pregeniculate lesions).

Lesions of lateral geniculate body have been found to produce incongruous wedge-shaped homonymous field defects but when the aetiology is ischaemic, the defect is usually congruous.

d. *Congruous hemianopia:* The outline of visual field loss in both eyes are similar, e.g. lesions of optic radiation (postgeniculate lesions).

Lesion of the optic radiation close to the calcarine cortex in the occipital lobe produces congruous hemianopia, as the fibres in the optic radiation are closely packed together.

e. *Bitemporal hemianopia:* This is produced by lesions of the optic chiasma caused by tumour of pituitary gland or *sella turcica* or by an inflammatory or traumatic lesion of optic chiasma. This may occur in 80% of people in whom the nasal fibres at *sella turcica* are affected. In 10%, the decussation may be pre-fixed, when a lesion at the *sella turcica* may cause a lesion of the optic tract. In the other 10% in whom the decussation may be post-fixed, the above lesion may involve the optic nerve.

Field defects of chiasmal lesions are produced by the following conditions:

1. Pituitary tumours
2. Craniopharyngioma

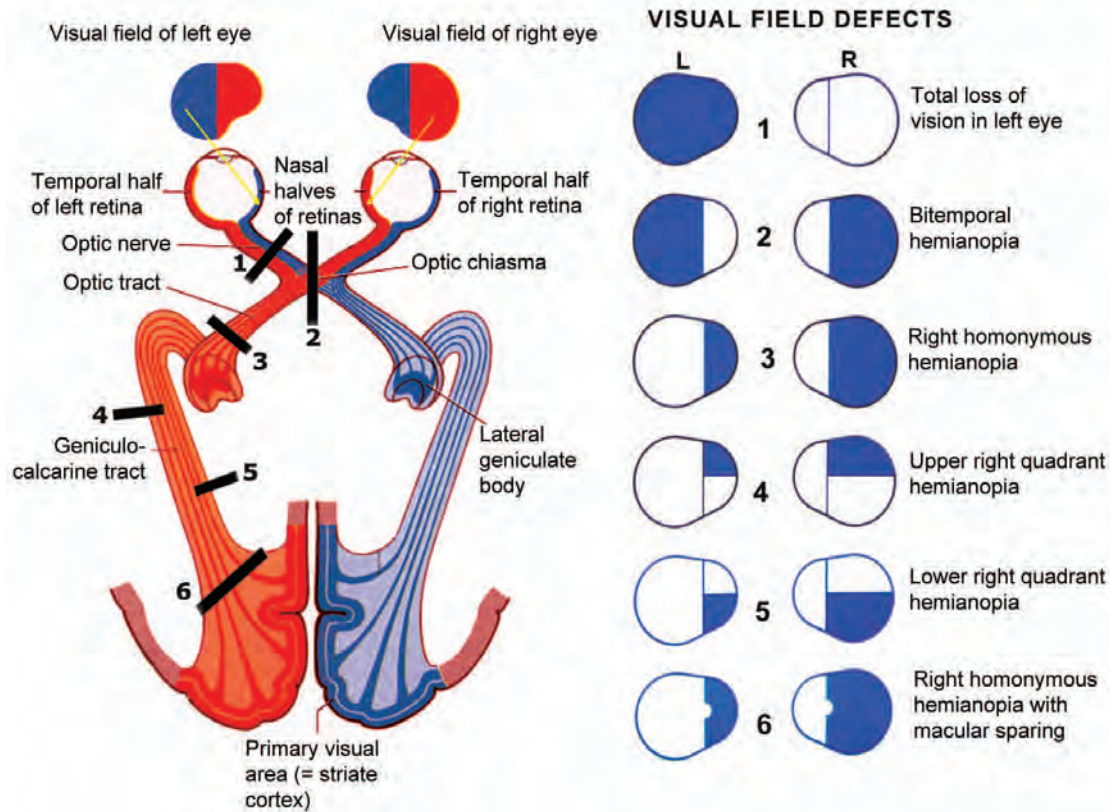

Fig. 8.10: Visual field defects

3. Meningioma
4. Chiasmal glioma
5. Distension of the third ventricle (hydrocephalus)
6. Internal carotid artery aneurysm
7. Mucocele of the sphenoid sinus
8. Granulomatous meningitis (TB, syphilis, sarcoidosis)
9. Head injury
10. Ischaemia.

Compression of the optic chiasma in the midline produces bitemporal hemianopia, along with progressive loss of visual acuity.

Compression of the optic chiasma in the lateral aspect on both sides produces binasal hemianopia (*example*: compression by atherosclerotic internal carotid or anterior cerebral arteries).

Pressure upon the optic chiasma from below produces bilateral upper temporal quadrantanopia (*example*: in the early stages of pituitary tumour).

Pressure upon the optic chiasma from above produces bilateral lower temporal quadrantanopia (*example*: distension of the third ventricle as occurs in hydrocephalus in the early stage).

f. Inattention hemianopia: It is an example of perceptual rivalry. It occurs in patients having a lesion in the parietal lobe, where patients fail to perceive an object in one half of visual field when presented simultaneously and bilaterally.

g. Quadrantic hemianopia: Superior and inferior quadrantic hemianopia means loss of upper and lower quadrants of the visual field respectively.

In temporal lobe lesions, affection of the optic radiation causes superior quadrantic hemianopia.

In parietal lobe lesions, affection of the optic radiation causes inferior quadrantic hemianopia.

Hemianopia with macular sparing is seen in

- i) Lesion of calcarine cortex.

h. Altitudinal hemianopia: It is due to partial lesion of the blood supply of the optic nerve as in vascular accidents or trauma (Fig. 8.11).

3. Concentric constriction of visual field

It occurs in long standing papilloedema, bilateral lesion of visual cortex, retinitis pigmentosa, and in hysteria.



Fig. 8.11: Altitudinal hemianopia

Monocular Visual Loss

- Optic neuritis
 - Viral (childhood)
 - Multiple sclerosis
 - Epstein-Barr virus
 - Post-infectious
 - Sphenoid sinusitis
 - Ischaemia-Giant cell arteritis
- Orbital tumour
- Vascular occlusion—Arterial/Venous

Binocular Visual Loss

- Chiasmal compression
- Elevated intracranial pressure
- Toxic- Methyl alcohol
- Infiltrative disorders
 - Malignancy
 - Lymphoma
 - Leukaemia
- Leber's optic atrophy

Colour Vision

The primary colours are red, green and blue. Blue colour has the maximum field of vision. Colour vision is tested by use of pseudo-isochromatic plates (Ishihara chart) (Fig. 8.12). Most common anomaly of colour vision are the various types of red-green deficiency inherited as sex linked recessive condition. Acquired defects of colour vision occur in macular and optic nerve diseases, and due to certain drugs, e.g. ethambutol, chloroquine.

Swinging Light Test for Afferent (Optic Nerve) Pupillary Abnormality

This test is done to detect a lesion in the afferent pathway, i.e. optic nerve. In this test, a bright light is swung from one eye to the other alternatively. The eye with optic nerve lesion will show a positive consensual light reflex, but will not show a positive direct light reflex. So, the affected pupil starts to dilate when direct light is thrown into that eye (Marcus Gunn's Pupil).

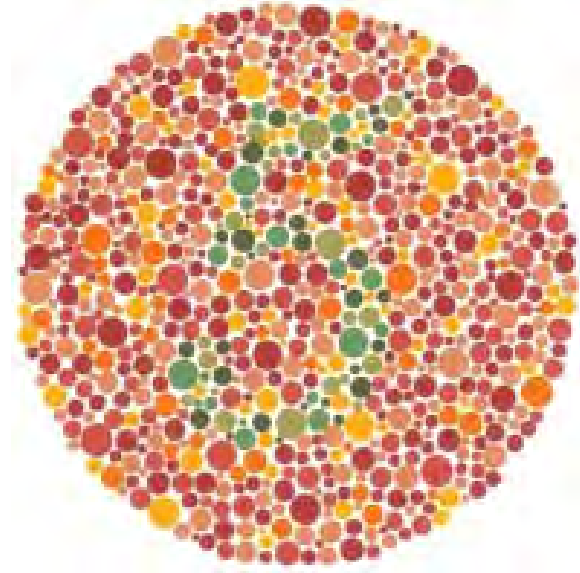

Fig. 8.12: Ishihara chart

Inspection of Optic Nerve Head and Fundus by Ophthalmoscopy (Fig. 8.13)



Fig. 8.13: Ophthalmoscopy

A. Papilloedema

It is the oedema of the optic disc > 3 dioptres (Fig. 8.14).

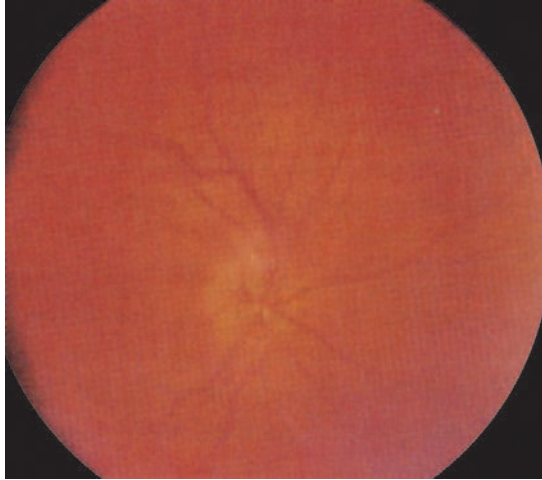

Fig. 8.14: Papilloedema

There are 4 stages of papilloedema.

1. Early Papilloedema.
 - a. Earliest change is blurring of superior and the inferior margin of disc.
 - b. Disc hyperaemia and dilated capillaries.
 - c. Spontaneous venous pulsations are absent.
 - d. Splinter haemorrhages at or just off the disc margin.
 - e. Optic cup is preserved.
2. Established papilloedema.
 - a. Disc margin becomes indistinct and central cup is obliterated.
 - b. Disc surface is elevated above the retinal plane.
 - c. Venous engorgement and peripapillary oedema.
 - d. Flame shaped haemorrhages and cotton-wool spots.
 - e. Radiating folds around macula.
3. Chronic papilloedema.
 - a. Central cup remains obliterated.
 - b. Haemorrhage and exudates gradually resolve.
4. Atrophic papilloedema.
 - a. Retinal vessels are attenuated with perivasular sheathing.
 - b. Dirty white appearance of optic disc due to reactive gliosis (secondary optic atrophy).

Causes of Papilloedema

1. Raised intracranial pressure:
 - a. Cerebral tumours
 - b. Cerebral abscess
 - c. Meningoencephalitis
 - d. Hydrocephalus
 - e. Cerebral oedema, haemorrhage, haematoma.

2. Venous causes:
 - a. Central retinal vein occlusion
 - b. Cavernous sinus thrombosis
 - c. SVC obstruction.
3. Arterial causes:
 - a. Hypertension
 - b. Vasculitis.
4. Haematological:
 - a. Anaemia
 - b. Polycythaemia.
5. Endocrine and metabolic:
 - a. Hypoparathyroidism
 - b. Graves' disease with severe exophthalmos
 - c. Hypercapnia.
6. Optic nerve damage:
 - a. Toxins (methanol, lead)
 - b. Foster-Kennedy syndrome (tumour near one optic foramen leading to optic atrophy on that side and papilloedema on the other side).
7. Infiltration of optic disc:
 - a. Sarcoidosis
 - b. Glioma
 - c. Leukaemia
 - d. Lymphomas.
8. Due to raised CSF proteins:
 - a. Guillain-Barré syndrome
 - b. Spinal cord tumours
 - c. Post-subarachnoid haemorrhage
 - d. Post-meningitis
9. *Pseudotumour cerebri*: This is usually an idiopathic condition, especially affecting young and obese women, who present with features of raised intracranial tension (headache, papilloedema and sixth nerve palsy). They may be treated with steroids or with the ventriculoperitoneal shunt.

Drugs causing pseudotumour cerebri

- a. Nalidixic acid
- b. Amiodarone
- c. Glucocorticoids
- d. Hypervitaminosis A
- e. Oral contraceptive pills
- f. Tetracyclines.

Papilloedema due to intracranial tumours

- Papilloedema is common in posterior fossa tumours and occurs early in tumours of the cerebellum and the fourth ventricle.
- Papilloedema is uncommon in tumours of the frontal lobe, temporal lobe, subcortical and pontine regions, and also in cerebello-pontine angle tumours.



Pseudo-papilloedema

In this condition, there is a filling up of the optic disc, but there is absence of venous congestion or swollen and proliferated capillaries around the disc margin.

It is due to congenital disc anomalies giving rise to apparent rather than true disc swelling. Small/absent optic cups, abnormal branching of the major retinal vessels and calcific excrescences may be seen.

Causes

1. Hypermetropia (due to increased myelin deposition anterior to the lamina cribrosa).
2. Congenital hyaline deposition within the optic disc.
3. Myelinated nerve fibres
4. Optic nerve drusen
5. Opacity in the media (nuclear sclerosis).

Transient loss of vision, while straining or bending forward in the presence of papilloedema is due to compression of the central retinal artery and is an indication for urgent removal of the underlying cause of papilloedema.

B. Optic Atrophy

Causes of Optic Atrophy

1. Primary (simple) optic atrophy

Primary optic atrophy is characterised by orderly degeneration of optic fibres and is replaced by columns of glial tissue without any alteration in the architecture of the optic nerve head (Fig. 8.15).

- a. Retrobulbar neuritis
- b. Trauma
- c. Toxic neuropathy (toxic amblyopias)
- d. Syphilis
- e. Neoplasms (sellar/parasellar tumours)



Fig. 8.15: Primary optic atrophy

2. Secondary optic atrophy

Secondary optic atrophy is characterised by marked degeneration of optic nerve fibres with excessive

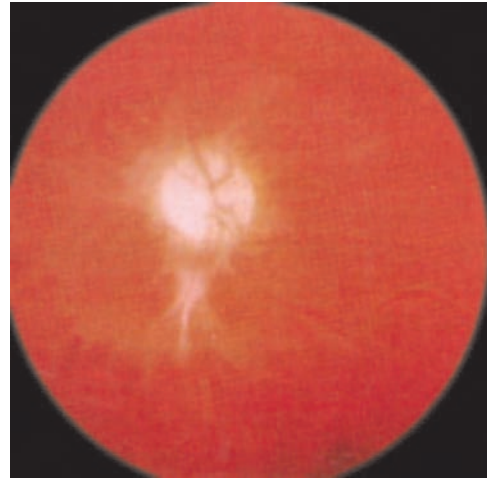

Fig. 8.16: Secondary optic atrophy

proliferation of glial tissue. The entire architecture of optic nerve head is lost resulting in indistinct disc margins (Fig. 8.16).

- a. Papillitis
- b. Papilloedema
- c. Vascular lesions.
3. Consecutive optic atrophy (consecutive to retinal disease)
 - a. Cerebro macular degeneration
 - b. Toxic retinopathy (quinine)
 - c. Retinitis pigmentosa (Fig. 8.17).
 - d. Ischaemic retinal infarction (central retinal artery obstruction)
 - e. Diffuse chorioretinitis
 - f. Extensive photo-coagulation.

Aetiologic Classification of Optic Atrophy

- a. Hereditary

Congenital or Infantile

1. Infantile hereditary recessive type (profound visual loss)

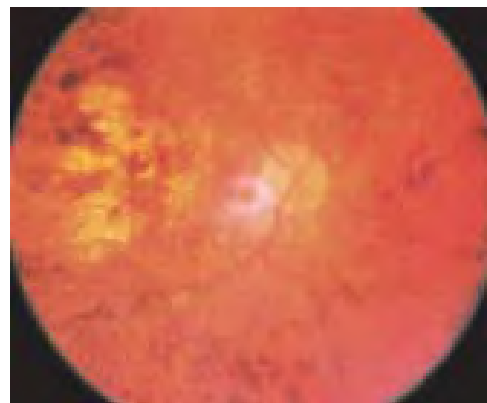

Fig. 8.17: Retinitis pigmentosa

2. Infantile hereditary dominant type (no blindness)
 - Leber's optic atrophy
 - Friedreich's ataxia
 - Marie's ataxia
 - Behr's hereditary optic atrophy
 - Lipidoses (cerebromacular degeneration).
- b. *Consecutive*
 - Chorioretinitis
 - Pigmentary retinal dystrophy
 - Cerebromacular degeneration
 - Extensive photocoagulation
 - Toxic (quinine) retinopathy
 - Myopic chorioretinal degeneration.
- c. *Circulatory*
 - Central retinal artery occlusion (Figs 8.18 and 8.19)
 - Carotid artery disease
 - Cranial arteritis
 - Post-haemorrhagic (GI Hge).



Fig. 8.18: Central retinal artery occlusion



Fig. 8.19: Central retinal vein occlusion

- d. *Metabolic*
 - Thyroid ophthalmopathy
 - Cystic fibrosis

- Juvenile diabetes mellitus
- Nutritional amblyopia.
- e. *Toxic amblyopia*
 - Ethambutol
 - Sulphonamides
 - Chloramphenicol
 - INH
 - Arsenic
 - Streptomycin
 - Lead.
- f. *CNS diseases*
 - Multiple sclerosis
 - Devic's disease
 - Herpes zoster
 - Charcot-Marie Tooth disease
 - Tabes dorsalis/GPI.
- g. *Pressure or traction atrophy*
 - Glaucoma (Fig. 8.20)
 - Papilloedema
 - Tumours of optic nerve
 - Arachnoiditis
 - Exophthalmos
 - Aneurysm.



Fig. 8.20: Glaucomatous optic disc with secondary atrophy

- h. *Post-inflammatory*
 - Optic neuritis
 - Perineuritis (post-meningitis, orbital cellulitis).

C. Papillitis

It is the edema of the optic disc < 3 dioptres. It is a painful condition of the eye. Patient experiences pain in the eye on moving the affected eyeball and there is a sudden loss of visual acuity.



Differentiation between Papilloedema and Papillitis

Papillitis	Papilloedema
1. Painful condition	Painless
2. Central scotoma	Peripheral constriction of visual field
3. Sudden loss of vision can occur	No visual loss
4. Swelling of disc < 3 dioptries	Swelling of disc > 3 dioptries
5. Due to demyelination	Causes listed above
6. Steroids (prednisolone 60 mg per day given early may shorten course of illness)	Treatment of the underlying cause

D. Retrobulbar Neuritis

The optic disc is normal even though patient is blind. The media of the eye is also normal. "Neither the doctor, nor the patient sees anything".

E. Examination of the Macula

The abnormalities of the macula that may be noticed are

1. Macular 'fan' (extension of oedema from optic disc to macula)

2. Macular haemorrhage (hypertension)
3. Cherry red spot (central retinal artery occlusion; Tay-Sach's disease).

Amaurosis fugax: It is a transient monocular blindness, lasting for a few seconds and occasionally for a few hours.

Causes

1. Migraine
2. Microembolism of central retinal artery with platelet or cholesterol emboli from ipsilateral carotid artery
3. Idiopathic.

The Oculomotor (Third), Trochlear (Fourth), and Abducent (Sixth) Cranial Nerves

These three nerves and their central connection are usually considered together, since they function as a physiological unit in the control of ocular movements (Fig. 8.21).

Features of Primary, Secondary and Consecutive Optic Atrophy

Features	Primary	Secondary	Consecutive
Disc	Papery white	Grey white	Waxy pale
Margin	Clear cut	Blurred margin	Normal
Physiological cup	Seen well	Filled up	Present
Lamina cribrosa	Prominent	Not seen	Not seen
Vessels in and around the disc (normally 9–10 vessels are seen)	Minimally seen on disc (Kestenbaum sign)	Sheathing of vessels close to disc	Vessels attenuated
Peripheral fundus	Normal; Vessels normal	Vessel changes seen (Haemorrhage and exudates may be seen)	Altered (pigment/degeneration)

Clinical Aspects of III, IV and VI Cranial Nerves

Name	Muscle supplied	Eye movements	Other functions	Signs of lesion
Oculomotor (III)	Superior rectus	Elevation (on abduction)	Elevated upper eyelid	Ptosis (ptosis may be bilateral in nuclear lesion); Dilated pupil; Abducted eye (divergent squint); The contralateral SR and ipsilateral IO and IR are affected
	Inferior rectus	Depression	Pupillary constrictor	
	Medial rectus	Adduction	Ciliary muscle	
	Inferior oblique	Elevation (on adduction)		
Trochlear (IV)	Superior oblique	Depression (on adduction)		Oblique diplopia on gazing down and inwards (on looking down and reading or while climbing downstairs); Intorsion of the conjunctival vessels on action of the SO muscle is noted
Abducent	Lateral rectus	Abduction		Horizontal diplopia on lateral gaze; Convergent squint

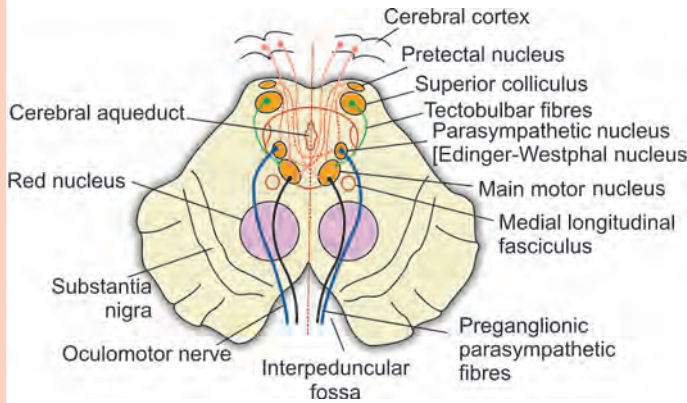

Fig. 8.21: Oculomotor nucleus and its connections

Anatomical Peculiarities

The oculomotor nuclear complex is located in the midbrain at the level of superior colliculus. It consists of one unpaired and four paired nuclear columns. The unpaired column constitute Edinger-Westphal nucleus and subnucleus for levator palpebrae superioris. The paired nuclei constitutes subnuclei for superior, inferior and medial recti and inferior oblique.

Trochlear nerve passes posteriorly and the fibres from the right and left trochlear nuclei decussate on the dorsum of mid brain. This is the only cranial nerve that emerges dorsally from the brainstem. The left trochlear nucleus sends fibres to the right superior oblique muscle, and vice versa.

Abducent nerve has a very long intracranial course and supplies the lateral rectus muscle.

Because of its long intracranial course, it is affected in conditions producing raised intracranial tension, thereby producing a false localising sign.

External Ocular Muscles and Their Actions (Fig. 8.22)

Upwards to the left	Upwards	Upwards to the right
Left SR Right IO	Left & Right SR Left & Right IO	Right SR Left IO
To the left	Straight ahead	To the right
Left LR Right MR	General contraction of all extraocular muscles	Right LR Left MR
Downwards to the left	Downwards	Downwards to the right
Left IR Right SO	Left & Right IR Left & Right SO	Right IR Left SO

- The eyes normally move 30° upwards, 50° downwards, 50° medially and 50° laterally.
- The recti are adductors and the obliques are abductors, in addition to their respective actions.

- In the abducted position, the recti are pure elevators or depressors. In the adducted position, the obliques are pure elevators or depressors.
- The obliques, due to their oblique placement, have an opposite action (SO causes depression and IO causes elevation of the eyeball).
- The superior oblique and superior rectus are internal rotators (*superiors are internal rotators*).
- Inferior oblique and inferior rectus are external rotators (*inferiors are external rotators*).

Pseudo-von Grafe's Sign

This sign occurs as a result of aberrant regeneration of the III nerve and may occur after trauma, aneurysm, congenital III nerve palsy or migraine.

The clinical signs include abnormal upper eyelid movement (lid elevation) on attempted ipsilateral adduction/depression of the eye.

There will be lid depression on attempted abduction of eyeball.

Examination of III, IV and VI Cranial Nerves

Inspection of the Eyes

1. Size of Palpebral Fissures

Look for narrowing of the palpebral fissures (*Ptosis*).

Ptosis may be congenital or acquired, unilateral or bilateral, partial or complete.

Congenital ptosis: It is due to bilateral congenital hypoplasia of the third nerve nuclei, and results in bilateral ptosis.

Acquired ptosis: Acquired ptosis may be unilateral or bilateral.

Causes for Unilateral Ptosis

- Third nerve lesion
 - Compression of third nerve by the uncus of temporal lobe during cerebral herniation
 - Compression of third nerve by aneurysm of posterior communicating artery, posterior cerebral artery, or internal carotid artery
 - Cavernous sinus thrombosis (usually the fourth and sixth cranial nerves are also involved)
 - Third nerve palsy can occur without involving the pupillary fibres in the following conditions:
 - Diabetes mellitus
 - Hypertension
 - Atherosclerosis
 - Collagen vascular disease.

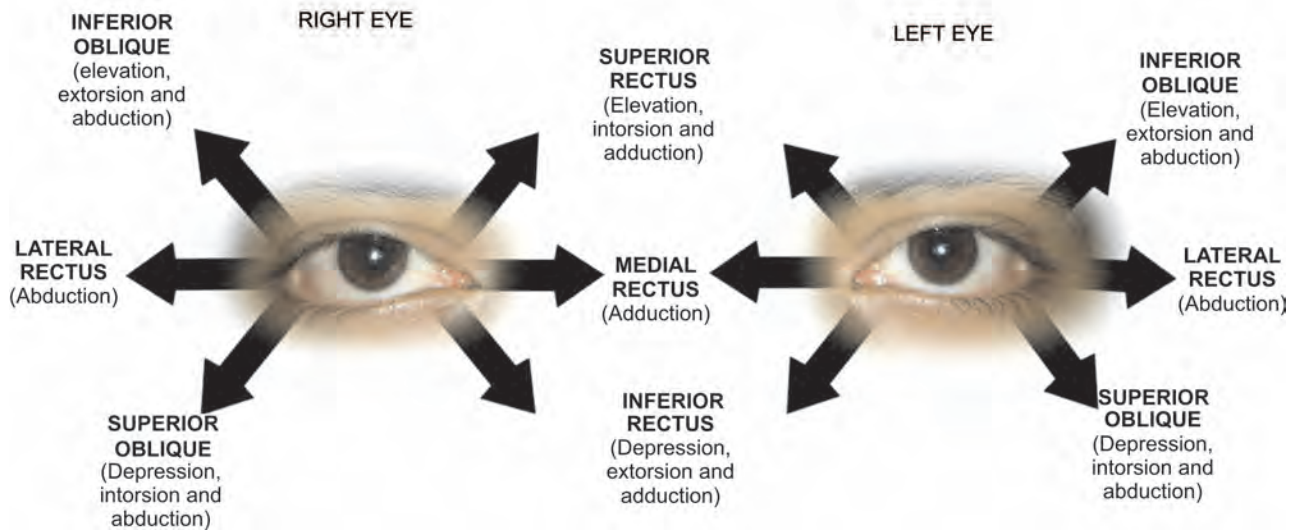
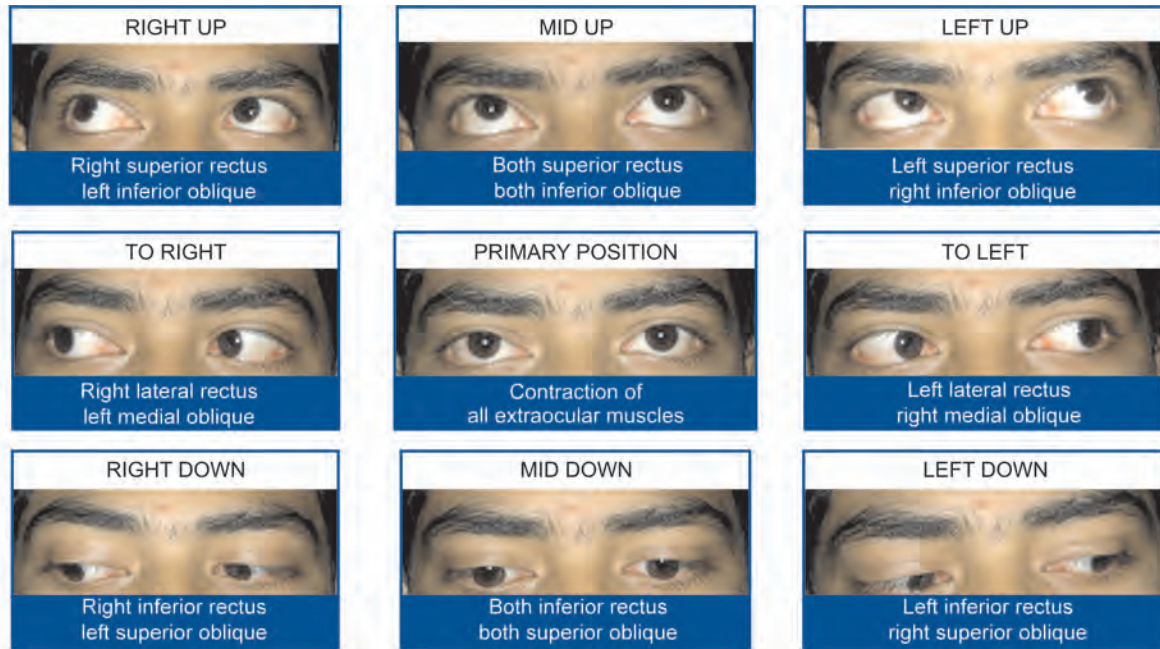

Fig. 8.22: Ocular movements and actions of individual ocular muscles

NB: The pupillary fibres are peripherally located in the optic nerve. So in compressive lesions there is early pupillary loss and ischaemic lesions there is pupillary sparing.

- Lesion of cervical sympathetic pathway (Horner's syndrome)
- Trauma
- Lesions of the upper eyelid.

Causes for Bilateral Ptosis

- Myopathies
- Myasthenia gravis
- Bilateral Horner's syndrome
- Bilateral ptosis occurs when there is a lesion of the third nerve nucleus, supplying the levator palpebrae superioris in the midbrain (as a single nucleus

in the midbrain supplies the levator palpebrae superioris of both eyes)

- e. Snake bite
- f. Botulism.

Partial Ptosis

This occurs with lesion of the cervical sympathetic pathway (Horner's syndrome) due to weakness of the tarsal muscles, innervated by cervical sympathetic nerves. The upper eyelids can however be raised voluntarily.

Complete Ptosis

This occurs with third nerve lesions due to paralysis of the levator palpebrae superioris, innervated by the third nerve. The patient is not able to voluntarily open the affected eye.

2. Size of Pupils

Normal size of pupil varies from 3 to 5 mm. Pupils < 3 mm size in average condition of illumination are called miotic and pupils > 5 mm are called mydriatic. Pin point pupil is said to be present when the pupillary size is less than or equal to 1 mm.

Causes for Miosis

- a. Old age
- b. Horner's syndrome
- c. Drugs or toxins
 - Neostigmine
 - Morphine
 - Organophosphorous poisoning
- d. Pontine haemorrhage.

Causes for Mydriasis

- a. Infancy
- b. Lesion of third cranial nerve (midbrain lesion)
- c. Drugs like atropine and pethidine
- d. Blindness due to optic nerve damage (optic atrophy).

Pupillary Reflexes

a. Light Reflex

Light reflex pathway: The light reflex is carried by the visual pathway up to the optic tracts, after which the fibres carrying this reflex are relayed to the Edinger-Westphal nucleus, bilaterally, and from here through the ciliary ganglion to the sphincter pupillae by the ciliary nerves (Fig. 8.23).

Direct and consensual light reflexes should be tested.

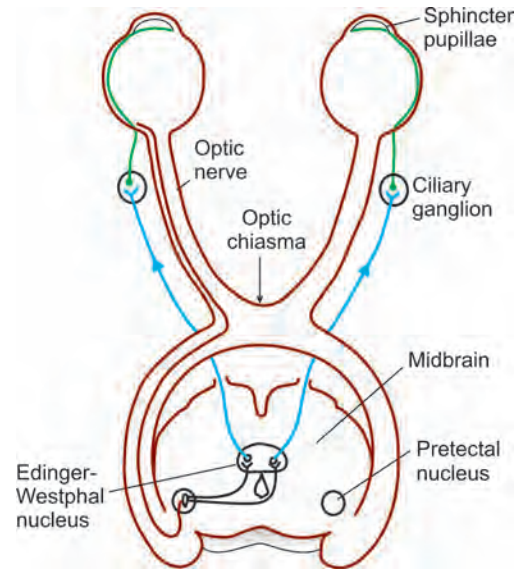

Fig. 8.23: Pathway of light reflex

Direct light reflex is elicited preferably in a dark room and by asking the patient to look at a distance (in order to avoid accommodation reflex). A bright light is then directed to the patient's eyes from the sides, one at a time, and a brisk contraction of the pupil is noted.

Consensual light reflex is elicited by placing a partition between the two eyes. Light source is directed to one eye and the consensual light reflex is noted in the other eye. Consensual light reflex is elicitable because of the bilateral innervation of the Edinger-Westphal nucleus by the fibres carrying the light reflex (Fig. 8.24).

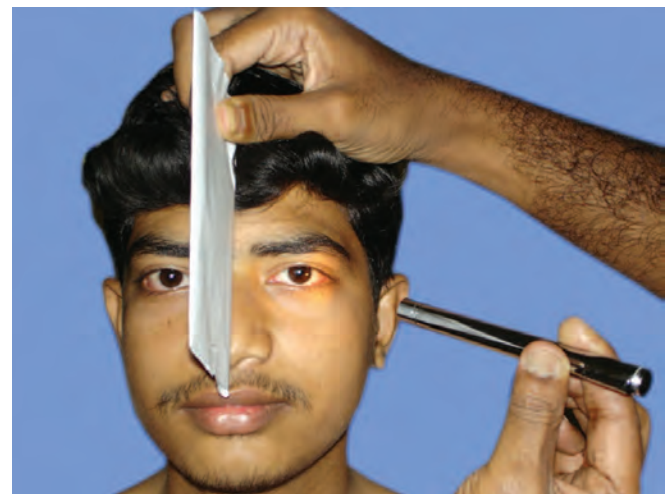

Fig. 8.24: Testing for consensual light reflex



Fig. 8.25: Testing for accommodation reflex

b. Reaction to Accommodation

Accommodation reflex pathway: The afferent stimulus for this reflex is carried from the retina via the optic nerve, tract and radiation to the calcarine cortex of the occipital lobe. From here, fibres pass to the frontal lobe and from here the corticobulbar fibres go to the third nerve nucleus (nucleus of the medial rectus and the Edinger-Westphal nucleus). The stimulation of these nuclei results in the accommodation reflex.

This reflex comprises of adduction (convergence) of the eyes when patient looks at a near object, accompanied by pupillary constriction (Fig. 8.25).

Argyll-Robertson pupil (absent light reflex and preserved accommodation reflex)

- i. Syphilis
- ii. Diabetes mellitus
- iii. Alcoholic polyneuropathy
- iv. Hypertrophic polyneuropathy
- v. Tumours of the pineal region (associated upward gaze palsy).

Reversed Argyll-Robertson pupil (absent accommodation reflex and preserved light reflex)

- i. Diphtheria
- ii. Parkinsonism (post-encephalitic)
- iii. Diabetes mellitus.

Ocular Movements

The ocular movements are tested by first asking the patient to look in different directions on command. Then patient is asked to follow an object held about 60 cm from patient's eye, which is moved in different directions, to test the different muscles of the eye. The patient is instructed to follow the moving object with his eyes and not to move his head.

Diplopia

This means double vision. It may be uniocular diplopia or binocular diplopia.

1. *Uniocular diplopia:* In this condition, diplopia occurs with monocular vision.

Causes of uniocular diplopia

- a. Ectopia lentis
- b. Astigmatism
- c. Lens opacities
- d. Corneal opacities
- e. Vitreous opacities.

Uniocular diplopia is always hysterical if the media is clear.

2. *Binocular diplopia:* In this condition, diplopia occurs only when both eyes are open. It is due to weakness of extra ocular muscles of the eye. The defective movement of the affected eye results in the image of the object falling on two different points on the retinae of the two eyes.

In binocular diplopia, two images, one real and one false, are formed. The real image is closer to the eye and is distinct, whereas the false image is farther away from the eye and is indistinct.

Red glass test: This test is performed to detect the affected eye in patients with diplopia. A red glass is placed over each eye, one at a time, and the patient is asked to look at an object, placed in the direction which produces diplopia with both eyes.

When the red glass is placed over the normal eye, the patient visualises the true image as red. When the red glass is placed over the affected eye, the patient visualises the false image as red.

Crossed diplopia occurs with adductor muscle paralysis. It is seen with medial rectus, superior rectus and inferior rectus paralysis.

Uncrossed diplopia occurs with abductor muscle paralysis. It is seen with lateral rectus, superior oblique and inferior oblique paralysis.

Strabismus or Squint

It is an abnormality of ocular movement, in which the visual axis do not meet at the point of fixation (Fig. 8.26).

There are two types of strabismus:

1. Paralytic strabismus
2. Concomitant strabismus.

Primary deviation: The deviation of the axis of the affected eye from the parallelism with that of the normal eye is called primary deviation.

Secondary deviation: If the patient is made to fix an object in a direction requiring the action of the affected muscle



Fig. 8.26: Left lateral rectus palsy

Differences between Concomitant Strabismus and Paralytic Strabismus

Concomitant strabismus	Paralytic strabismus
1. Begins in early childhood	Acquired later in life
2. Movement of the eye, tested individually, is full in all directions	Movement of the affected eye is limited in the direction of action of the muscle paralysed
3. Diplopia almost never a symptom	Diplopia always a symptom
4. Primary and secondary deviations are equal	Secondary deviation more than primary deviation
5. Deviating eye usually has defective vision	No defective vision

and at the same time is prevented from seeing it with his normal eye, the latter deviates too far in the required direction. This is called secondary deviation, and is due to the increased effort evoked by the patient's attempt to move the affected eye.

Upper Motor Neuron (Supranuclear) Lesions Supranuclear Pathway

The third, fourth and sixth cranial nerves have two supranuclear pathways.

1. *Fronto-mesencephalic-pontine pathway:* This pathway is concerned with voluntary conjugate eye movements (saccades).

This pathway originates in the frontal eye field in the contralateral middle frontal gyrus (Brodmann's area 8). Stimulation in this area gives rise to conjugate deviation of the eyes to the opposite side. The pathway from the

frontal cortex descends through the corona radiata, internal capsule, and cerebral peduncle, decussates at the level of pons, and descends to synapse in the contralateral PPRF.

2. *Parietal and temporo-mesencephalic-pontine pathway:* This pathway is concerned with pursuit eye movements.

This pathway originates in the posterior parietal lobe and adjacent superior temporal sulcus and anterior temporal lobe. Fibres descend unilaterally to the pons to join the medial longitudinal fasciculus at about the level of the sixth nerve nucleus.

Upper motor neuron lesion of the III, IV and VI cranial nerves leads to conjugate gaze palsy.

Paralysis of lateral conjugate gaze is found with a lesion of the pontine paramedian reticular formation (PPRF).

Paralysis of conjugate upward gaze is found with a lesion of midbrain at the level of superior colliculus.

Paralysis of conjugate downward gaze is found with lesion of midbrain at the level of inferior colliculus and lower brainstem.

Internuclear Lesions

MLF connects ipsilateral 3rd nerve nucleus with contralateral 6th nerve nucleus.

Internuclear ophthalmoplegia is a result of lesions in the medial longitudinal fasciculus. It is characterised clinically by the failure of adduction of eye on the side of lesion of MLF and a mild weakness of abduction with nystagmus on the contralateral side (Fig. 8.27).

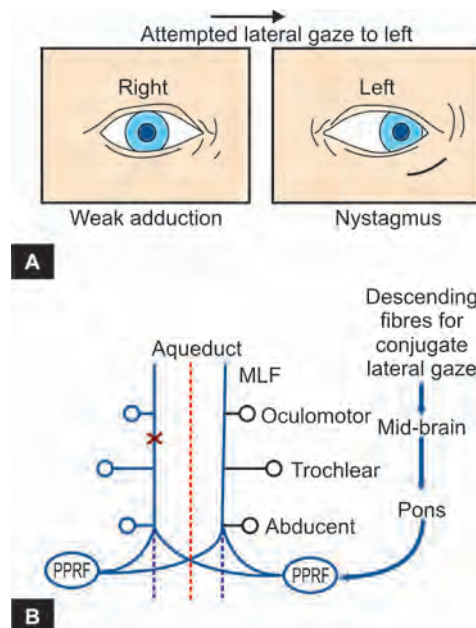

Fig. 8.27: Internuclear connections

- Right internuclear ophthalmoplegia
- Interconnection between III, IV & VI nerve nuclei with PPRF via MLF.



Anterior or superior internuclear ophthalmoplegia: In addition to the above features, there is a defective convergence on the ipsilateral side. The lesion is near the midbrain.

Posterior or inferior internuclear ophthalmoplegia: It is similar to internuclear ophthalmoplegia. But the convergence is spared. Lesion is near the pons.

One and a half syndrome: PPRF lesion in combination with MLF lesion is the cause for 1½ syndrome. There is a total lack of horizontal movement on the ipsilateral eye whereas in the contralateral eye only weak abduction is possible.

Internuclear ophthalmoplegia is a common sign in infarction and multiple sclerosis (MS). When present bilaterally, it is pathognomonic of MS.

Nystagmus

It is a disturbance of ocular movement characterised by involuntary, conjugate, often rhythmical oscillation of the eyes.

Pathophysiology of Nystagmus

Posture of the eyes is influenced reflexly by many factors, the most important of which are impulses derived from (1) retina (2) labyrinths, and (3) neck.

All these impulses go to the vestibular nucleus and from there to the cerebellum and cortex. Interference anywhere in this pathway may cause nystagmus.

Nystagmus may therefore be due to

1. Defective or abnormal retinal impulses
2. Disease or dysfunction of the labyrinths, vestibular nuclei or connection in the brainstem
3. Lesions of cervical spinal cord
4. Lesions involving central pathways controlling ocular posture
5. Congenital and of unknown aetiology
6. Toxic
7. May be mimicked voluntarily.

Types of Nystagmus

1. *Pendular nystagmus:* Rapid horizontal oscillations to either side of the midline, of equal amplitude, seen on forward gaze.
Causes: Visual defects from infancy (macular abnormalities, chorioretinitis, albinism, high infantile myopia, opacities in the media, retinitis pigmentosa).
2. *Jerky nystagmus:* Ocular oscillations of unequal amplitude, with slow drift in one direction and fast correcting movement in the other, the fast phase determining the direction of nystagmus.

Grading of Jerky Nystagmus

Grade I: Nystagmus with fast phase to left, looking towards the left only.

Grade II: Nystagmus with fast phase to left, looking straight ahead.

Grade III: Nystagmus with fast phase to left, looking towards right.

Types and Cause of Jerky Nystagmus

1. *Horizontal nystagmus:* It is a to and fro movement of the eyeball in a horizontal plane. It is seen in the following conditions:
 - a. Vestibular nerve lesion
 - b. Vestibular nuclei lesion
 - c. Lesion of medial longitudinal bundle
 - d. Lesions of the cerebellum (nystagmus to the side of lesion).
2. *Vertical nystagmus:* It is an up and down movement of the eyeball in a vertical plane. It is seen in the following conditions involving the brainstem:
 - a. Vascular accident
 - b. Encephalitis
 - c. Multiple sclerosis
 - d. Syringobulbia.
 - e. Drugs (anticonvulsants, benzodiazepines, barbiturates)
 - f. Wernicke's encephalopathy.
3. *Rotatory nystagmus:* It is an oscillatory movement of the eyeball which is rotatory in character. It is seen in labyrinthine disorders.

Horizontal nystagmus	Cerebellar lesion
(maximal on gaze to the side of lesion)	
Vertical nystagmus	Brainstem lesion
Rotatory nystagmus	Labyrinthine lesion
(maximal on gaze opposite to the side of lesion)	

This need not be the case always.
4. *Nystagmus due to spinal cord lesions:* It is rarely seen after cervical cord lesions. Nystagmus is attributed to defect of transmission of afferent impulses.
5. *Optokinetic nystagmus:* It is normally present on seeing moving objects (e.g. seeing a rotating striped drum, or seeing outside a window in a moving train). It is absent in deeply situated parietal lobe lesions, when the drum is rotated towards the side of the lesion. It is suppressed in the opposite side by a lesion in the supramarginal and angular gyri.
6. *Rare forms of nystagmus*
 - a. *See saw nystagmus:* There is spontaneous nystagmus, with one eye going up while the other eye goes down. It is seen in suprasellar region lesion.



Differentiation of Peripheral and Central Nystagmus

<i>Sign or symptom</i>	<i>Peripheral (Labyrinthine)</i>	<i>Central (Brainstem or cerebellar)</i>
1. Direction of nystagmus	Unidirectional; fast phase opposite to lesion	Bidirectional or unidirectional
2. Purely horizontal nystagmus without torsion	Uncommon	Common
3. Vertical or purely torsional nystagmus	Never present	May be present
4. Visual fixation	Inhibits nystagmus	No inhibition
5. Common causes	Infection (Labyrinthitis), Meniere's disease, ischaemia, trauma, toxin	Vascular accident, demyelinating disorder, neoplasms

Common Lesions Affecting the III Cranial Nerve

<i>Site</i>	<i>Pathology</i>	<i>Clinical features</i>
Midbrain	Infarction Haemorrhage Demyelination	May or may not affect pupil; may be bilateral; may be associated with a) Contralateral cerebellar or rubral tremor (<i>Claude's syndrome</i>) b) Contralateral hemiparesis (<i>Weber's syndrome</i>) c) Both (a) & (b) (<i>Benedict's syndrome</i>) d) Both (a) & (b) and vertical gaze palsy (<i>Nothnagel's syndrome</i>)
Circle of Willis	Aneurysm at origin of posterior communicating artery	Pupil involved early; headache over affected eye
Cavernous sinus	Internal carotid aneurysm	Ophthalmic division of V nerve as well as IV and VI nerves also involved; pain and proptosis of the eye
Orbit	Sinus thrombosis Infarction of nerve, e.g. diabetes; giant cell arteritis	Pupil often spared; may be painful

Common Lesions Affecting the IV Cranial Nerve

<i>Site</i>	<i>Pathology</i>	<i>Clinical features</i>
Cavernous sinus	Carotid aneurysm Thrombosis	Usually involved with ophthalmic division of V nerve and III and VI nerves
Orbit	Trauma	Superior oblique palsy
Orbital fissure	Tumour, granuloma	Pain in the eye with involvement of III and VI nerves

Common Lesions Affecting the VI Cranial Nerve

<i>Site</i>	<i>Pathology</i>	<i>Clinical features</i>
Pons	1. Congenital absence of nucleus (<i>Mobius' syndrome</i>) 2. Infarction/Haemorrhage (<i>Millard-Gubler syndrome</i>)	Ipsilateral conjugate gaze palsy + facial weakness Ipsilateral VI & VII LMN lesion and contralateral hemiplegia
Tentorial orifice	Compression Meningioma	May be secondary to raised intracranial pressure as a false localising sign
Cavernous sinus	Carotid aneurysm Thrombosis	Usually involved with ophthalmic division of V nerve and III and IV nerves.
Orbit	Infarction Tumour	May be secondary to diabetes or giant cell arteritis



Combined Ocular Motor Nerve Palsies (III, IV and VI)

Site	Cause	Clinical features
Brainstem	Tumour Infarction Wernicke's syndrome	Associated brainstem signs
Subarachnoid	Meningitis (infective and neoplastic) Trauma	Associated other cranial nerve palsies
Cavernous sinus and superior orbital fissure	Aneurysm Tumour (meningioma, nasopharyngeal carcinoma) Infection Carotico-cavernous fistula Tolosa-Hunt syndrome Herpes zoster Mucormycosis Cavernous sinus thrombosis	Ophthalmic division of V nerve involved
Orbital	Trauma Tumour Orbital cellulitis	Associated proptosis
Uncertain localisation	Dysthyroid eye disease Guillain-Barre syndrome Miller-Fisher syndrome Cranial arteritis	Associated signs of underlying lesion

- b. *Convergence retraction nystagmus*: Attempt upgaze, which is usually defective, provokes jerky nystagmus with fast phase in convergent direction. It occurs in upper midbrain lesion, near the pineal gland.
 - c. *Upbeat nystagmus*: There is vertical nystagmus, with fast phase upwards. It is seen in midbrain lesion.
 - d. *Downbeat nystagmus*: There is a vertical nystagmus, with fast phase downwards. It is seen in CV junction anomalies and in lesions of the lower medulla.
 - e. *Rebound nystagmus*: It is an uncommon variety of nystagmus of phasic type and occurs on looking laterally, but fatigues after about 20 seconds. When eye returns to midline, nystagmus to opposite side develops and also quickly fatigues. It seems to be due to cerebellar degeneration.
2. The mesencephalic nucleus receives unconscious proprioceptive information from periodontal membrane, palate, masticatory muscles and the temporomandibular joint.
 3. Descending tract of trigeminal nerve or bulbospinal tract (carrying pain and temperature) extends as low as 2nd cervical segment of the cord before it crosses and ascends in the medial lemniscus.

In this tract the ophthalmic division is lowermost and the mandibular division is uppermost (upside down representation of the face).

 - The lateral part of the face is represented caudally and the medial part of the face is represented rostrally.
 - In cases of upward extension of a cervical cord lesion (e.g. syringomyelia), from C₃ → C₂, there is initially loss of sensation over the lateral half of the face, which then extends to the medial aspect of the face in an 'onion skin' fashion.

Fifth Cranial Nerve (Trigeminal Nerve)

Nucleus

1. The principal nucleus of the trigeminal nerve carries posterior column sensation (touch, joint position sense and two-point discrimination) from the face. Fibres from this nucleus then cross over to the opposite side and ascend up to the thalamus in the quintothalamic tract.

A. Sensory System

Pain, temperature, light touch are examined in the following territories (Fig. 8.28):

- i. Ophthalmic division (forehead and upper part of the side of the nose)
- ii. Maxillary division (the malar region and upper lip)
- iii. Mandibular division (chin and anterior part of the tongue). The angle of the jaw and the ear lobe are supplied by C₂.

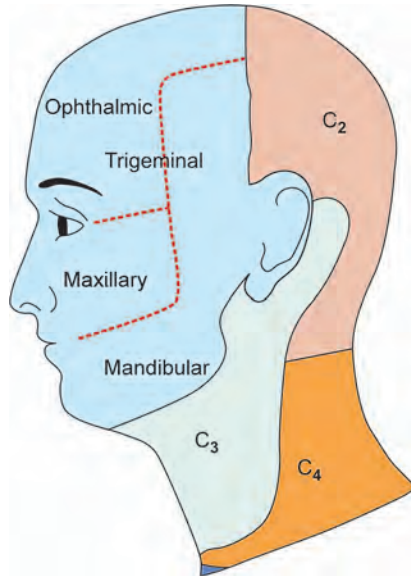

Fig. 8.28: Cutaneous distribution of V nerve

B. Motor System

Masseter and Temporal Muscles: Note the symmetry of the temporal fossa and the angles of the jaw. Paralysis results in hollowing of the temple and flattening of the angle of the jaw. Palpate the muscles while the patient clenches his jaws. The muscles can be compared as they stand out as hard lumps (Fig. 8.29).



Fig. 8.29: Palpate the masseters

Pterygoids: Weakness causes the jaw to deviate towards the paralysed side on opening the mouth, as a result of action of the normal muscle (medial and lateral pterygoids).



Method of testing
conjunctival reflex

Method of testing
corneal reflex

Fig. 8.30: Corneal-conjunctival reflex

C. Reflexes

Corneal reflex: This test must be first explained to the patient. Lightly touch the lateral edge of the cornea and the adjoining conjunctival margin with a wisp of cotton, having asked the patient to gaze into the distance or at the ceiling. Normally there is bilateral blink, whichever side is tested (Fig. 8.30).

Receptor Free nerve endings (pain reflex)

Afferent Trigeminal nerve (descending or bulbospinal tract)

Efferent Facial nerve

Corneal reflex is lost in any lesion involving the reflex arc. It may also be lost in lesions of parietal lobe.

Jaw jerk: Patient is asked to let his jaw sag open slightly. The examiner then places the left forefinger below the lower lip and taps it in a downward direction with the percussion hammer (Fig. 8.31). There may be a slightly palpable upward jerk of the jaw immediately after tapping.

Jaw jerk is exaggerated in pseudobulbar palsy.



Fig. 8.31: Strike the hammer in a downward direction



Blink reflex (glabellar reflex, orbicularis oculi reflex)

Percussion over the supraorbital ridge results in bilateral contraction of the orbicularis oculi muscle.

Afferent: Trigeminal nerve

Efferent: Facial nerve.

Lesions of the Vth Cranial Nerve

1. Nuclear Lesion

This occurs due to diseases affecting the pons, medulla and upper cervical cord (upto C₂).

Causes

- Tumour
- Demyelination
- Vascular lesions
- Syringomyelia/syringobulbia.

Dorsal midpontine lesion will result in ipsilateral atrophy and weakness of the muscles of mastication along with ipsilateral facial sensory loss with a contralateral hemiplegia and hemianaesthesia.

Lesions of the lower end of medulla and upper cervical cord will affect the spinal tract of the trigeminal nerve. This results in ipsilateral loss of pain and temperature over the face and contralateral hemianaesthesia and hemiplegia.

Vascular lesion involving the trigeminal nerve nucleus is seen as a part of the lateral medullary syndrome (occlusion of the posterior inferior cerebellar artery). There is ipsilateral loss of pain and temperature over the face and contralateral hemianaesthesia. There is associated ipsilateral Horner's syndrome, ipsilateral cerebellar signs and symptoms of vertigo, nausea, and vomiting.

2. Preganglionic Trigeminal Nerve Lesions

Causes

- Tumours (meningioma, nasopharyngeal carcinoma, cerebello-pontine angle tumour)
- Meningeal irritation (acute or chronic meningitis, carcinomatous meningitis).

These lesions are usually accompanied by lesions of other cranial nerves, especially the VIth, VIIth and VIIIth cranial nerves.

3. Gasserian Ganglion Lesions

These lesions are characterised by facial pain, which is often severe.

Causes

- Tumours
- Abscess
- Herpes-zoster (herpes zoster ophthalmicus).

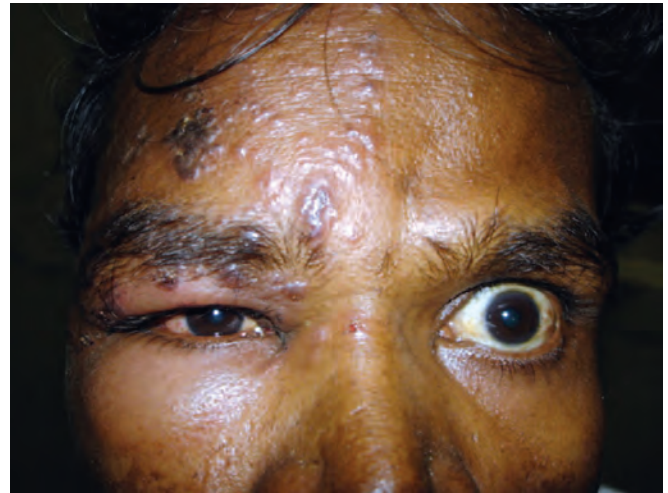

Fig. 8.32: Herpes zoster ophthalmicus

Herpes-zoster ophthalmicus: Herpes-zoster commonly affects the ophthalmic division of the fifth cranial nerve. It is associated with a number of complications like pain and burning dysaesthesia (post-herpetic neuralgia), uveitis, keratitis and corneal perforation (Fig. 8.32).

Reader's paratrigeminal syndrome: This results due to lesion close to the Gasserian ganglion. It is characterised by unilateral Horner's syndrome, without facial anhidrosis (as the sudomotor fibres to the face are not involved), and ipsilateral loss of facial sensation.

4. Postganglionic Nerve Lesions

Causes

- Cavernous sinus lesion (associated with III, IV and VI cranial nerve palsies)
Mandibular branch of V nerve is characteristically spared.
- Gradenigo's syndrome:* This is due to osteitis of the apex of the petrous temporal bone, associated with otitis media and results in
 - Ipsilateral Vth nerve palsy (ophthalmic and maxillary divisions)
 - Ipsilateral VIth nerve palsy
 - Retro-orbital pain.
- Superior orbital fissure syndrome (associated with III, IV, VI cranial nerve palsies, maxillary and mandibular branches being spared).

Seventh Cranial Nerve (Facial Nerve)

Anatomical Peculiarity

The upper half of the face has a bilateral representation by the facial nerve, whereas the lower half of the face has a unilateral representation.

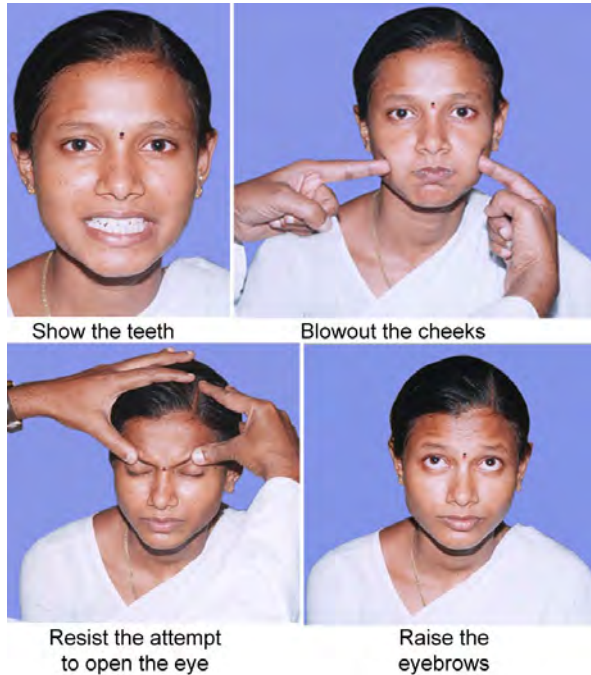

Fig. 8.33: Testing the motor functions of facial nerve

Inspection

1. Observe the face for any asymmetry which may be related to paresis of facial muscles
2. Observe the symmetry of blinking and eye closure and the presence of any tics or spasms of the facial musculature
3. Observe spontaneous movements of the face, particularly the upper and lower facial musculatures during actions such as smiling.

Examination of Motor Function

The motor function of the facial nerve is tested by asking the patient (Fig. 8.33).

1. To raise the eyebrows
2. Wrinkle the forehead by asking the patient to look upwards at the examiner's hand, held above
3. Close the eyes as tightly as possible
4. To show the teeth; the angle of the mouth is drawn to the healthy side
5. To blow out the cheeks against the closed mouth; air can be made to escape from the mouth more easily on the weak or paralysed side by tapping the inflated cheek with the finger
6. To purse the mouth
7. To whistle.

Voluntary and emotional responses of all muscles are compared.

The tone of the muscles of facial expression is noted.

Examination of Sensory Functions

Taste

- The tongue must be kept protruded during the entire test and the patient should not be allowed to speak during the examination.
- Examine the anterior two-third portion of each half of the tongue separately.
- Gently hold the protruded tongue with a swab, and wipe off the saliva.
- Use strong solutions of sugar and common salt and weak solutions of citric acid and quinine to test for 'sweet', 'salty', 'sour' and 'bitter' taste respectively. Quinine should be applied last.

Localisation of Level of Facial Nerve Lesion (Figs 8.34 and 8.35)

Site	Lesion	Clinical features
Cortex (supranuclear)	Cerebral infarction Haemorrhage Tumour	Contralateral facial weakness mainly of lower face (UMN palsy) often associated with hemiparesis on the same side
Pons (nuclear)	Infarction Demyelination Haemorrhage Tumour	LMN type of ipsilateral face weakness; often VI nerve also affected; contralateral hemiparesis
Cerebello-pontine angle	Acoustic neuroma Meningioma	LMN type of ipsilateral face weakness; deafness and tinnitus; ophthalmic division of V nerve affected
Facial canal (petrous bone)	Bell's palsy Mastoiditis Herpes-zoster (Ramsay-Hunt Syndrome)	LMN type of ipsilateral face weakness ± loss of taste, salivation and lacrimation, if lesion is proximal to chorda tympani ± hyperacusis if lesion is proximal to nerve to stapedius
Parotid gland	Tumour Sarcoidosis	Selective weakness of parts of face due to branch involvement
Neuromuscular junction	Myasthenia gravis	Associated ptosis and external ophthalmoplegia, dysphagia, dysarthria, ± limb weakness
Muscles	Muscular dystrophy Myositis	Limb muscles also weak; tenderness of muscles involved

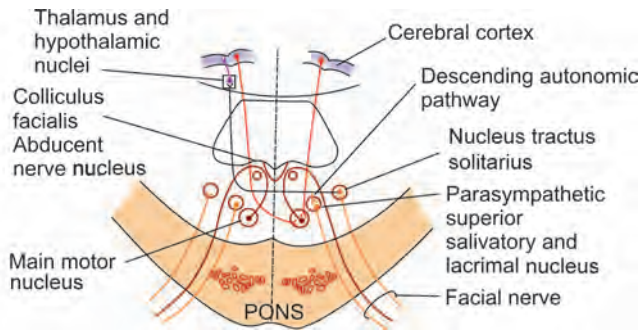

Fig. 8.34: Central connections of facial nerve nuclei

- Ask the patient to identify the substance by pointing to the appropriate word written on a card.

Examination of the Secretory Functions

Lacrimation

Increased lacrimation is usually apparent and decreased lacrimation may be determined from the history.

Schirmer's Test

Keep a piece of special blotting paper under the lower eyelid and remove it after 5 minutes. Normally at least

10 mm of the blotting paper will be dampened by the evoked tear secretion.

Nasolacrimal Reflex

Reflex secretion of tears usually produced by stimulation of nasal mucosa by irritating substances such as dilute solutions of ammonia or formaldehyde.

Afferent Trigeminal nerve

Efferent Greater superficial petrosal nerve (a branch of facial nerve).

Salivation

- Increased or decreased salivation is also apparent from the history
- Place highly flavoured substance upon the tongue
- Ask the patient to elevate the tongue
- A copious supply of saliva is seen to flow from the submandibular duct if there is no interference with the secretory functions.

Examination of the Reflexes

Corneal Reflex

Afferent Trigeminal nerve (descending or bulbospinal tract)

Efferent Facial nerve.

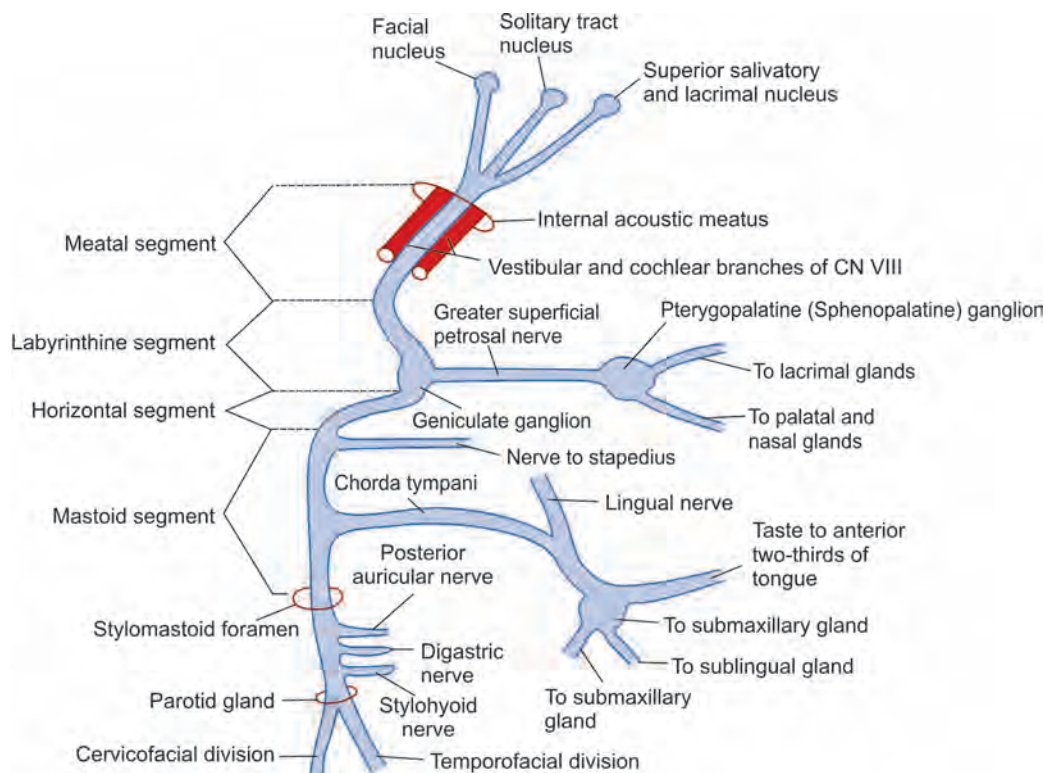

Fig. 8.35: The course of facial nerve

Stapedial Reflex

When the stapes is stimulated by a loud noise, normally the reflex contraction of stapedius leads to reduction in transmission of the sound.

Weakness of the stapedius muscle is not apparent objectively, but the patient may complain of hyperacusis especially for low tones.

Afferent Vestibulocochlear nerve

Efferent Facial nerve.

Common Causes of VII Nerve Palsies

Unilateral	Bilateral
<i>UMN</i>	
Usually vascular	Often vascular (multi-infarct dementia)
Cerebral tumour	Motor neuron disease
Multiple sclerosis	
<i>LMN</i>	
Bell's palsy	Guillain-Barre' syndrome
Parotid tumour	Sarcoidosis-Uveoparotid fever
Head injuries	Leprosy
Skull base tumours	Leukaemia/Lymphoma
Diabetes	
Hypertension	

Facial Nerve Involvement in Leprosy

- Branches are affected
- Upper fibres are more affected
- Patchy involvement
- Asymmetrical involvement.

Bilateral UMN Palsy	Bilateral LMN palsy
Bell's phenomenon—absent	Bell's phenomenon—present
Emotional fibres—spared	Emotional fibres—affected
Associated with long tract signs	Long tract signs absent
Jaw jerk—exaggerated	Jaw jerk—normal
Corneal reflex—present	Corneal reflex—absent

Bell's Palsy

It is due to an acute onset of non-suppurative inflammation of the facial nerve within the facial canal above the stylomastoid foramen, producing a unilateral lower motor neuron type of facial palsy.

- Aetiology of Bell's palsy is not known. At times, Bell's palsy can be bilateral.
- Diabetes mellitus and hypertension have been seen to be associated with Bell's palsy in 10 to 14% of patients, especially after the age of 40 years. These are other causes of LMN type of facial palsy.
- Bell's palsy is associated with the presence of herpes simplex virus 1 DNA in endoneurial fluid and posterior auricular muscle suggesting the possibility that a reactivation of this virus in the geniculate

ganglion may be responsible. However, the causal role of this virus is unproven.



Clinical Features

The onset is often sudden. Paralysis is partial in 30% and complete in 70% of cases.

The voluntary, emotional, and associated movements of the upper and lower facial muscles are usually involved.

Frowning and raising the eyebrows are impossible. Bell's phenomenon is noted.

Bell's Phenomenon

- Normally, on closing the eye, the eyeball moves upwards and inwards. This movement is well appreciated in patients with Bell's palsy, when they attempt to close the eye on the affected side.
- The nasolabial furrow is less prominent on the affected side, and the mouth is drawn to the normal side.
- The patient cannot retract the angle of the mouth on the affected side.
- The patient cannot hold air in the mouth on the affected side.
- If lesion extends upwards to involve the nerve above the point at which the chorda tympani leaves it (6 mm above stylomastoid foramen), there is loss of taste on the anterior two-thirds of the tongue, on the affected side.
- In about a third of cases, the branch to the stapedius is involved leading to hyperacusis on the affected side.

Poor Prognostic Factors

1. Age above 60 years
2. Presence of hyperacusis
3. Diminished lacrimation
4. Associated hypertension or diabetes mellitus
5. No return of voluntary power or total inexcitability of the nerve by needle electrode.



Complications

In those cases in which recovery is incomplete, contracture often develops in the paralysed muscles and may give a normal appearance to that side. However, the paralysis becomes evident when the patient smiles.

Clonic facial spasm is an occasional sequel.

Syndrome of crocodile tears: It is characterised by unilateral lacrimation on eating and is due to an aberrant regeneration of facial nerve fibres. Degeneration of the greater superficial petrosal nerve that innervates the lacrimal gland, causes sprouting of nerve fibres from



the lesser superficial petrosal nerve (innervates the parotid gland), at the point where they meet. These sprouts from the lesser superficial petrosal nerve innervate the lacrimal gland, thereby causing a flow of tears and not saliva while eating.



Treatment

About 70 to 80% of patients with Bell's palsy recover spontaneously within 2–12 weeks, especially when there is a partial involvement of the facial muscles in the first week.

A short course of steroids, after excluding the concomitant presence of hypertension and diabetes mellitus, (dexamethasone 2 mg tid or prednisone, 60–80 mg/day for five days and gradually tapering over the next five days) may be helpful if the patient is seen within 48 hours of the onset of symptoms.

In one study, Patients treated within 3 days of onset with both prednisone and acyclovir 400 mg 5 times/day for 10 days has a better outcome than with prednisone alone.

Physiotherapy of the affected facial muscles.

Care of the eye, by using eye pads, when there is incomplete closure of the eye on the affected side.

Ramsay-Hunt syndrome: This is due to affection of the geniculate ganglion by Herpes zoster.

Patients present with vesicular lesions over the external auditory meatus and pharynx, lower motor neuron type of facial nerve palsy, loss of taste, salivation and lacrimation and hyperacusis if stapedius is weak. Often the eighth cranial nerve may also be affected.

Mimic paralysis: It is due to frontal or thalamic lesions, which abolish the contralateral emotional movements of the face, leaving the voluntary movements unimpaired.

Mobius' syndrome: This is due to a congenital absence of facial nerve nucleus, presenting with lower motor neuron type of facial nerve palsy.

It is usually associated with absence of the sixth nerve nucleus, resulting in associated horizontal gaze palsy.

Melkersson Rosenthal syndrome: There is a recurrent unilateral lower motor neuron type of facial nerve palsy, with facial oedema and a fissured tongue.

The Eighth Cranial Nerve (Vestibulocochlear Nerve)

Examination of Auditory Function

A. By the Use of the Human Voice

- Patient should not face the examiner.

- Non-test ear must be adequately blocked or masked by the use of Barany's apparatus or by producing a noise in the non-test ear by friction of hair over that ear. This test must preferentially be done in a sound-proof room.
- Examiner should use unfamiliar words or spondee (i.e. words which will not give a clue to the patient as to the context of the question asked)
Example: If the patient is asked 'what is your age?' the patient may only hear the word 'age' and guess the question asked.

Normal conversational voice should be heard at 20 ft.

Whispering voice should be heard at 10 ft.

B. Watch Test

Quartz watch should be avoided.

The watch test may be used at the bedside if early aminoglycoside toxicity is suspected.

C. Tuning Fork Tests (A 512 Hz Tuning Fork is Used)

(i) *Rinne's Test:* It compares air conduction with bone conduction. Strike a tuning fork gently and hold it near one external auditory meatus. Mask the other ear and ask the patient if he can hear it. Place the vibrating tuning fork on the mastoid process and ask the patient if he can hear it and tell him to say the moment the sound ceases. When he does so, at once place the parallel blades of the fork near the external auditory meatus. Normally, the vibrating note continues to be heard.

In a normal person, air conduction is better than bone conduction. This is called positive Rinne test.

If bone conduction is better than air conduction, it is known as negative Rinne test (Fig. 8.36).



Fig. 8.36: Rinne's test

*Interpretation**Rinne Positive*

- i. normal ear
- ii. nerve deafness (sensorineural deafness)*

Note: *In sensorineural deafness, both air and bone conduction are decreased. However, air conduction is still better than bone conduction. Presence of sensorineural deafness can be definitely ascertained by doing the absolute bone conduction test or by audiometry.

Rinne Negative

- i. middle ear deafness (conductive deafness)
- ii. *Weber's Test:* The vibrating tuning fork is placed on the centre of the forehead, or vertex of the head. The patient is asked if he can hear the vibrating sound at the point of application of tuning fork, or in both ears equally or in any one ear predominantly (Fig. 8.37).

Interpretation

- i. The vibrating sound is heard at the point of application of the tuning fork (no lateralisation) Normal ears
 - ii. The vibrating sound is better heard in the normal ear (lateralised to the normal ear) Nerve deafness (sensorineural deafness on the opposite side)
 - iii. The vibrating sound is better heard in the affected ear (lateralised to the affected ear) Conductive deafness on the same side
- iii. *Absolute Bone Conduction Test (Schwabach test):* It is the most simple and reliable test, provided the examiner has normal auditory function. The essence of the test is to compare the bone conduction of the patient with that



Fig. 8.37: Weber's test

of the examiner. The bone conduction is made absolute for clinical purpose by occluding the external auditory meatus. The vibrating tuning fork is placed on the mastoid bone of the patient first, and when the patient ceases to hear the vibrations, it is placed on the examiner's mastoid bone.

Interpretation

- i. ABC equal for patient and examiner (the patient ceases to hear the vibration of the tuning fork at the same time as the examiner). This test is recorded as *ABC normal*.
- ii. ABC increased for patient (the patient continues to hear the vibration of the tuning fork, while the examiner ceases to hear it). This test indicates that the patient has *conductive deafness*.
- iii. ABC decreased for patient (the patient ceases to hear the vibration of the tuning fork, while the examiner continues to hear it). This test indicates that the patient has *sensorineural deafness*.

Audiometric Tests

1. Subjective Hearing Tests

i. *Pure tone audiometry:* Quantitative measurement of hearing—particularly important in detecting early nerve deafness.

- High tone loss is characteristic of nerve deafness.
 - Low tone loss is characteristic of middle ear deafness.
- ii. *Speech discrimination audiometry:* Discrimination of speech is affected, in about 75% of VIII nerve tumours.

iii. *Loudness recruitment (alternate binaural loudness balance test):* Phenomenon of recruitment is due to lesions of cochlear end organ. To ears showing recruitment, a puretone will be just audible when the intensity is slightly greater than the hearing threshold, but intense sounds (80–100 dB) create a sensation of loudness at least as great as that experienced by a normal ear at that intensity.

iv. *Decruitment*

Tone decay tests: Measure the decay of an auditory stimulus presented to the test ear.

Decay of less than 15 dB	-	Normal
Decay in excess of 20 dB	-	Neural lesion.

2. Objective Hearing Tests

- i. *Impedance measurements:* Impedance of the tympanic membrane is estimated by measuring the amount of sound reflected from the membrane under various external pressures.
- ii. Evoked response audiometry.



Test of Vestibular Function

Fistula Sign

Increase the pressure in external acoustic meatus by otoscopy or by the use of a Siegel's pneumatic speculum or by repeatedly pressing the tragus of the ear against the external auditory meatus. If jerk nystagmus results, then a 'fistula sign' is said to be present, suggesting that the entire bony labyrinthine wall has been breached so that pressure changes are transmitted directly to the membranous labyrinth.

Oculocephalic Reflex or Doll's Eye Movement

1. Stand behind the patient at the head end of the bed.
2. Slightly flex and support the patient's head.
3. Briskly rotate the head from one side to the other and note lateral movements of the eyes.

The normal response is for the patient's eyes to deviate to the left as the patient's head is turned to the right and vice versa. It is a definite sign of normal midbrain function. Its absence suggests brain death.

Positional Vertigo

Vertigo is induced by certain head postures or by sudden changes in head position.

Provocative Test for Positional Vertigo

- Support the patient's head, with eyes open, and lower it briskly below the horizontal plane of the couch, turning the head to one side.
- Repeat the test, turning the head to the other side.
- Note the response of the eyes to head movement, and look for presence of nystagmus.
- A person with positional vertigo will develop vertigo with the above test and nystagmus will also be seen.
- Nystagmus will not be seen in normal people and patient is asymptomatic (no vertigo).

Labyrinthine lesion	Central lesion
1. Nystagmus develops after an interval of 5–15 sec	Nystagmus develops immediately
2. Adaptation rapidly occurs	Adaptation does not occur
3. Nystagmus directed towards the side of lesion	Direction of nystagmus altered by varying the head posture
4. Cannot usually be elicited again on repeated testing	Can be readily reproduced within 10–15 minutes
5. Visual fixation inhibits nystagmus	Visual fixation does not inhibit nystagmus

Caloric Testing

This simple, reliable test is performed with the patient lying on a couch, with the head elevated to 30 degrees, in order to bring the lateral semicircular canals into the vertical plane. The patient is instructed to fix upon a point in central gaze and the external ear canal is irrigated with water at 30°C and then at 44°C for 30–40 seconds each. In patients with perforated tympanic membrane, air is used. This test causes a thermal gradient across the temporal bone which produces convection current within the endolymph. The slow phase of the nystagmus is always in the direction of flow. The nystagmus is always named after its quick phase.

Response in Normal Ear

Cold water Nystagmus away from the ear being irrigated (**O**pposite side)
 Warm water Nystagmus towards the ear under test (**S**ame side)
 Pneumonic: **COWS**

Abnormal Responses

i) *Canal paresis*: No response or diminished response to both warm and cold water on one side.

Conditions

- a. Lesions of labyrinth (Meniere's disease)
- b. Vestibular nerve (acoustic nerve tumour, vestibular neuronitis)
- c. Lesions of the vestibular nuclei.

ii) *Directional preponderance*: Response is always reduced for irrigations producing nystagmus in the same direction.

Conditions

- a. Brainstem lesion
 - b. Cortical lesion (posterior temporal lobe lesion).
- In brainstem lesion, the directional preponderance is away from the side of lesion.

In posterior temporal lobe lesions (cortical centre for the tonic pathway), the directional preponderance is towards the side of lesion (Figs 8.38A to C).

Vertigo

It is a hallucination of movement of either the body (or part of it) or the surroundings.

The perceived movement may be of falling down, or rotating or there is a sensation of spinning of the outside world.

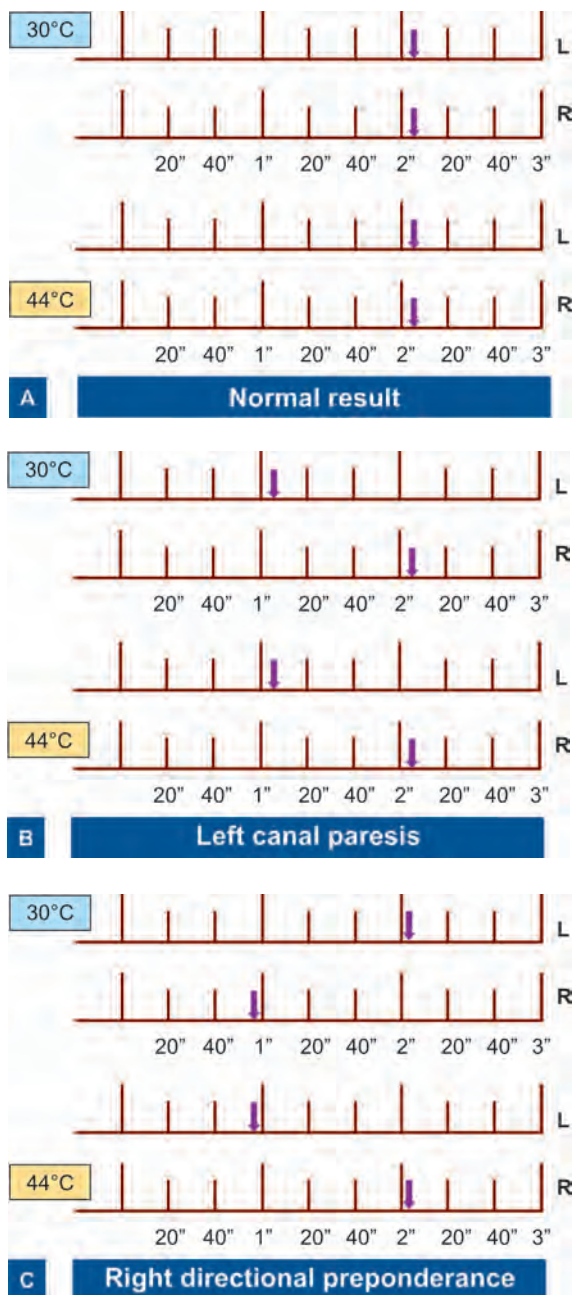

Figs 8.38A to C: Caloric testing

Deafness

Deafness is often accompanied by tinnitus, especially when the lesion lies in the cochlea or auditory nerve. It may be either *conductive deafness* or *sensorineural deafness*.

Conductive deafness is usually due to blockage of the external auditory meatus (e.g. by wax), damage to the tympanic membrane, or damage to the ossicular chain.

Lesions Causing Vertigo

Site of lesion	Example	Clinical features
Labyrinth	Meniere's disease	Vertigo, deafness, tinnitus
VIII nerve	Acoustic neuroma	Deafness, tinnitus, vertigo, cerebellar signs, associated V and VII nerve lesions
Vestibular neurons	Vertebral artery ischaemia	Vertigo, ataxia, diplopia, syncope, dysarthria
Cerebellum	Tumour; infarct	Vertigo, ataxia, dysarthria
Temporal lobe	Epilepsy; tumour	Vertigo accompanying seizures

Differences between Central and Peripheral Vertigo

Signs or symptoms	Peripheral (Labyrinth)	Central (Brainstem or cerebellum)
1. Direction of nystagmus	Unidirectional	Bi or Unidirectional
2. Pure horizontal	Uncommon	Common (especially cerebellum)
3. Vertical or pure torsional	Never	May be present (especially brainstem)
4. Effect of fixation	Inhibits nystagmus	No inhibition
5. Severity of vertigo	Marked	Mild
6. Direction of spin	Towards fast phase	Variable
7. Direction of fall	Towards slow phase	Variable
8. Duration of symptoms	Acute but recurrent	Chronic
9. Tinnitus/Deafness	Often present	Usually absent
10. Associated central abnormality	None	Common

Sensorineural deafness is due to the disease of the cochlea, or the auditory fibres in the VIII nerve and its connections in the brainstem.

Peripheral Labyrinthine Disorders

Perilymphatic Leaks

This occurs after head injury or barotrauma. This causes sudden hearing loss, tinnitus and occasionally vertigo. The symptoms are worsened on lying down on the affected side. Most leaks heal spontaneously.

Benign Positional Vertigo

This may occur following head injury or other acute labyrinthine disorders (viral labyrinthitis). Vertigo is



evoked by turning over towards the affected ear and symptoms last for up to 30 seconds. It may be associated with nausea and vomiting.

Vestibular Neuronitis

This is characterised by vestibular symptoms and signs without any other cochlear or neurological dysfunction. A previous history of upper respiratory tract infection is present in most patients.

Meniere's Disease

This condition results from idiopathic distension of the endolymphatic system (endolymphatic hydrops). The mean age of onset is about 50 years.

This condition gives rise to recurrent attacks of severe vertigo, often with vomiting and prostration, usually associated with tinnitus and increasing deafness. In the later stages, hearing loss is permanent, and as the damage to the inner ear increases, vertigo becomes less frequent.

Acoustic Neuroma

Acoustic neuromas arise from Schwann cells of the eighth cranial nerve, most commonly within the internal auditory meatus.

- They occur in up to 1% of population.
- They account for about 10% of all intracranial neoplasms.
- They account for 70–80% of cerebello-pontine angle lesions.

Some of these acoustic neuromas are due to von Recklinghausen's disease (Type II), in which they are present bilaterally.

Deafness and tinnitus are the most common forms of presentation and vestibular symptoms are frequently absent as the pathology progresses slowly and allows compensation to occur.

As the tumour extends into the cerebello-pontine angle, the fifth and seventh cranial nerves also become involved, i.e. corneal reflex is lost early.

In the late stages, there may be displacement of the brainstem and there is gradually increasing intracranial pressure.

It is important to diagnose this condition early, as they are then amenable to surgical removal. Late diagnosis may present with an inoperable tumour.

Suspect acoustic neuroma in patients with either unilateral or bilateral sensorineural deafness.

The Ninth and Tenth Cranial Nerves (Glossopharyngeal and Vagus Nerves)

These cranial nerves are tested together as follows:

- General sensation and taste sensation* is tested in the posterior 1/3 of the tongue. This is done by using a galvanic current.
- Palatal reflex*: The patient is placed, facing the light, with his mouth open. A tongue depressor is introduced for better visualisation of the palate. The position of the arches of the soft palate on both sides and that of the uvula are noted. The patient is then asked to say 'ah' and the elevation of the soft palate on both sides and the uvula is noted.

Interpretation

In case of *unilateral palatal palsy*, the palatal arch on that side is at a lower level than on the healthy side. On saying 'ah', the uvula is pulled to the healthy side by the normal palate. There is little or no movement of the affected palate.

In case of *bilateral palatal palsy*, the palate remains immobile on both sides.

Palatal myoclonus is seen in autosomal dominant cerebellar ataxia (ADCA) or olivopontocerebellar atrophy (OPCA). This involuntary movement is present even during sleep.

The site of the lesion is in the triangle of Guillian and Mollaret (It is the triangle formed between Red nucleus, Dentate nucleus and Olivary nucleus). Usually caused by vascular, traumatic, neoplastic and demyelinating diseases.

- Gag reflex*: This is tested by tickling the pharynx and noting the reflex contraction of the pharynx thus produced.

Interpretation

- This reflex is absent on the side of lesion of the ninth and tenth cranial nerves (lower motor neuron type of palsy).
- Exaggerated gag reflex is seen in pseudobulbar palsy (upper motor neuron type of palsy).
- If on eliciting the gag reflex, the patient is able to feel the tickling sensation, but there is no reflex contraction of the pharynx, then only the tenth cranial nerve may be affected, and that the ninth cranial nerve is intact. However, it is very rare to see this lesion (involvement of the tenth and sparing of the ninth cranial nerve) clinically (Fig. 8.39).

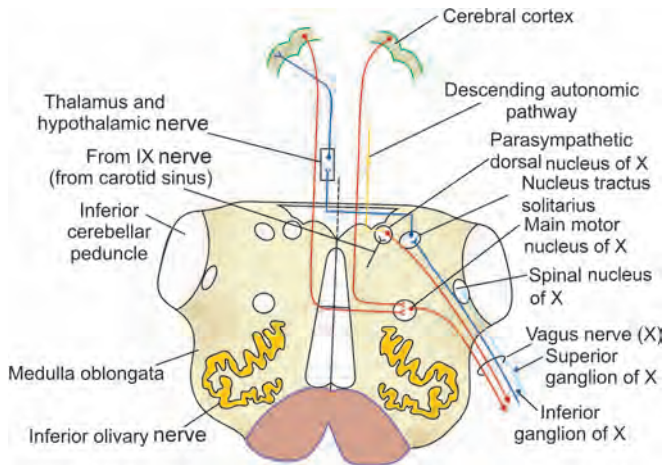

Fig. 8.39: Vagus nerve nuclei and their central connections

Eleventh Cranial Nerve (Accessory Nerve)

This is a pure motor nerve supplying the sternocleidomastoids and the trapezius muscles.

Testing of Sternocleidomastoid Muscle

The examiner's hand is placed on one side of the patient's face and the patient is asked to turn his head against the force applied by the examiner's hand. The sternocleidomastoid muscle on the side opposite to the direction of head movement is seen to stand out prominently in a normal person. This test is repeated by asking the patient to turn his head against resistance in the opposite direction (Fig. 8.40).



Fig. 8.40: Turn the head against resistance

Features of Unilateral Paralysis of the Sternomastoid

1. Muscle is wasted and less prominent than its fellow, on turning the head to the opposite side.
2. Weakness of rotation of head to the opposite side.
3. On flexing the neck against resistance applied to the chin, the head deviates towards the paralysed side due to the normal action of the opposite muscle.

Lesions of Cranial Nerves IX, X and XI

Site	Causes	Clinical features
Medulla-lateral	Infarction (PICA) Syringobulbia Tumour Demyelination	Nasal voice, palatal weakness, absent gag reflex, impaired sensation posterior 1/3 tongue and pharyngeal wall, laryngeal stridor, bovine cough
Jugular foramen (Vernet syndrome)	Glomus tumour Metastatic tumour Meningioma	As above + spinal accessory nerve affected (weakness of trapezius and sternomastoid)
Diffuse lesions	Polyneuritis Guillain-Barre syndrome Motor neuron disease Myasthenia gravis	No sensory deficit (usually bilateral involvement)
Supra-nuclear (cortex, pyramidal tract)	Stroke Cerebral tumour Demyelination Motor neuron disease	Unilateral lesions do not cause persisting deficit (bilateral representation); bilateral lesions cause loss of coordination of pharynx and palate and brisk gag reflex (pseudobulbar palsy)

Testing of the Trapezius Muscle

The patient is asked to shrug his shoulders against resistance, applied on them by the examiner, while standing behind the patient (Fig. 8.41).

Features of Unilateral Paralysis of the Trapezius

1. There is drooping of the shoulder on the affected side.
2. The scapula is rotated downwards, and outwards, with the lower angle being nearer the midline than the upper part of scapula.
3. Weakness of shrugging of shoulder on affected side and inability to raise the arm above the head after it has been abducted by the deltoid.



Fig. 8.41: Shrug the shoulders against resistance

The Twelfth Cranial Nerve (Hypoglossal Nerve)

The patient is asked to put out his tongue.

1. Look for any deviation of the protruded tongue.
2. Look for any abnormal movement of the tongue (flicking in and out movement of the tongue as in chorea).
3. Assess the strength of each half of the tongue by asking the patient to push against the examiner's finger kept over the cheek with his tongue.
4. Look for any wasting, tremor or fibrillation.

Fibrillation must be assessed with the tongue relaxed in the oral cavity and not when protruded.

LMN Palsy	UMN Palsy
i. Wasting present	No true wasting
ii. Fibrillation may be seen	No fibrillation
iii. Protrusion of tongue is possible and the tongue deviates to the affected side	Protrusion of tongue is difficult
iv. Tongue is flaccid	Tongue is small and spastic
v. Jaw jerk is normal	Jaw jerk is exaggerated (bilateral)

Causes of Lesions of the Hypoglossal Nerve

Site	Causes
i. Hypoglossal nucleus	Infarction Syringobulbia Tumour Motor neuron disease
ii. Base of skull	Metastatic tumour Meningioma Vertebral artery aneurysm Cranio-vertebral anomalies (e.g. basilar invagination) Trauma
iii. Neck	Surgery (e.g. carotid endarterectomy)

Causes of Multiple Cranial Nerve Palsies

Site	Cranial nerves involved	Usual cause
Sphenoid fissure (superior orbital)	III, IV, first division of V and VI	Invasive tumours of sphenoid bone
Lateral wall of cavernous sinus	III, IV, first division of V and VI often with proptosis	Aneurysms or thrombosis of cavernous sinus; invasive tumours from paranasal sinuses and sella turcica; benign granulomas
Retrosphenoid space	II, III, IV, V and VI	Large tumours of middle cranial fossa
Apex of petrous bone	V, VI	Petrositis; tumours of petrous bone
Internal auditory meatus	VII, VIII	Tumours of petrous bone (dermoid etc.); infectious processes; acoustic neuroma
Pontocerebellar angle	V, VII, VIII and sometimes IX	Acoustic neuroma, meningioma
Jugular foramen	IX, X and XI	Tumours and aneurysms
Posterior laterocondylar space	IX, X, XI and XII	Tumours of parotid gland, carotid body and metastatic tumour deposits
Posterior retro parotid space	IX, X, XI, XII and Horner's syndrome	Tumours of parotid gland, carotid body; metastatic tumour deposits; tuberculous adenitis

Pure motor cranial nerves are III, IV, VI, XI and XII cranial nerves.

Pure sensory cranial nerves are I, II and VIII cranial nerves.

Mixed motor and sensory cranial nerves are V, VII, IX and X cranial nerves.

Spinomotor System

The spinomotor system is primarily concerned with the execution of smooth and coordinated voluntary movements.

The components of the motor system:

1. The corticobulbar and corticospinal (upper motor neuron).
2. The basal ganglia and cerebellum.
3. The neuromuscular system (lower motor neuron).

A particular movement is initiated when the idea of the movement is first invoked in the association areas of the cortex in which recall of acquired motor skills

(praxis) is stored. The appropriate motor cells of the precentral cortex are then activated and impulses travel down the pyramidal tracts, and activate the appropriate anterior horn cells and the motor units. Simultaneously the movement is influenced and controlled by the activity of the cerebellum and of the components of the extrapyramidal motor system.

Lesions of the motor system might result in total weakness (paralysis), or partial weakness (paresis) or involuntary movements or ataxia.

The Corticobulbar and Corticospinal (Pyramidal) System

The upper motor neurons, which constitute this pathway, arise in part from nerve cells in the precentral motor cortex of the cerebrum. Some of these neurons arise from the giant Betz cells which are common in this area. Pyramidal fibres originate from primary motor cortex, premotor cortex, supplementary motor cortex, somatosensory cortex (areas 1, 2, 3, 5, 7).

One-third of the fibres arise from area 4, one-third from area 6 and the rest from parietal lobe (Fig. 8.42).

The somatic body representation in the precentral motor cortex is such that the face, hands, fingers, upper limb and trunk occupy the lateral surface of the cortical hemisphere and the leg and foot area lies partly on the medial surface of the hemisphere and partly on its

superior aspect. The maximal representation in the cortex is for the lip, thumb and other fingers. Each cortical hemisphere controls movement of the body on the opposite side.

In man, the pyramidal tract contains about 10,00,000 fibres. Nerve fibres arising from these cortical cells (including Betz cells) then come together in the corona radiata and converge upon the internal capsule. In the internal capsule, the fibres lie in the middle third of the posterior limb. From the internal capsule, the tract passes down in the middle three-fifths of the cerebral peduncle to enter the midbrain. In the pons, it is broken into bundles by transverse pontine fibres. In the medulla, it again becomes a compact tract. Throughout the brainstem, the tract gives off corticobulbar fibres which travel to the contralateral motor nuclei of the cranial nerves. In the lower part of the medulla, most fibres of the pyramidal tract decussate to form the crossed pyramidal tract which descends in the lateral column of the spinal cord on the opposite side. A small proportion do not do so and continue downwards in the anterior column, forming the direct or uncrossed pyramidal tract which extends downwards only as far as the dorsal spinal cord and they supply the axial muscles.

Fibres of the pyramidal tract do not synapse directly with the anterior horn cells, but end in the posterior horn cells and from there through internuncial neurons in the grey matter of the spinal cord, the fibres synapse in the anterior horn cells. From the anterior horn cells, the lower motor neuron arise.

Signs of Pyramidal Tract (Upper Motor Neuron) Lesion

1. No muscle wasting (however, muscle wasting can occur in the late stages due to disuse atrophy)
2. Increased muscle tone (in the form of clasp knife spasticity affecting mainly the antigravity muscles, flexor group of muscles in the upper limb and extensor group of muscles in the lower limb)
3. Paralysis of voluntary movement
 - a. Early distal weakness involving fine movements of the hand
 - b. Other muscles that are involved early are
 - i. Shoulder abductors
 - ii. Muscles of hand grip
 - iii. Hip flexors
 - iv. Foot dorsiflexors
 - c. The weakness is more in extensors of the upper limbs and flexors of the lower limbs (opposite to that of tone distribution)
 - d. The group of muscles first affected are the last to recover (fine distal movements of the hand are the last to recover)

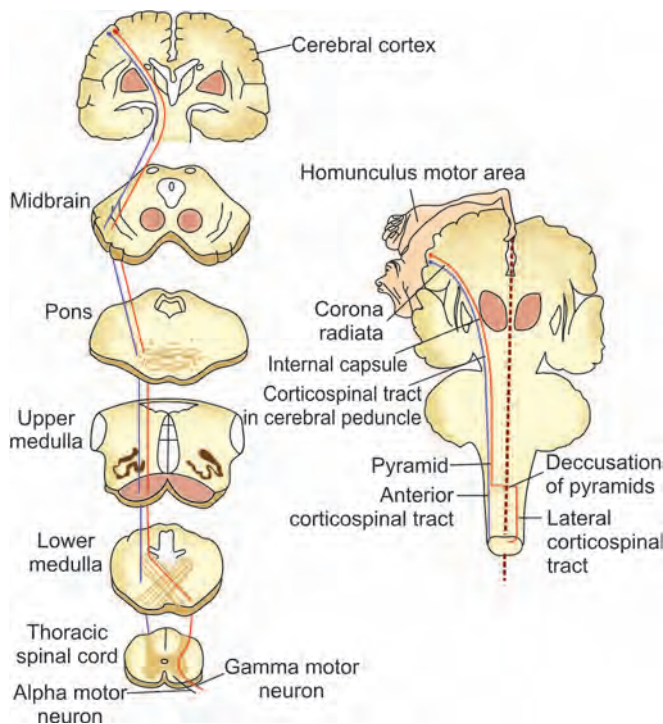

Fig. 8.42: Corticospinal tract



4. Absent abdominal reflex
5. Positive Babinski's sign (extensor plantar response)
6. Brisk or exaggerated deep tendon reflexes and sustained clonus.

The Extrapyramidal System

This consists of basal ganglia and their connections.

It is a complex system of neurons and fibres which have reciprocal connections with the cerebral cortex, thalamus, cerebellum, brainstem nuclei and spinal cord. This system refers to all the descending tracts other than the corticospinal tract (rubrospinal tract, tectospinal tract, reticulospinal tract and vestibulospinal tract).

The Basal Ganglia

The basal ganglia are group of nuclei situated deep within the substance of the cerebral hemispheres and brainstem, and include the caudate nucleus, putamen, globus pallidus (or pallidum), the claustrum, subthalamic nucleus, and substantia nigra (Fig. 8.43).

The putamen and pallidum together form the lentiform nucleus.

The caudate, putamen, and pallidum nuclei are collectively referred to as corpus striatum. The corpus striatum plays an important role in the regulation of posture.

Phylogenetically, the pallidum (paleostriatum) is older than the caudate nucleus and putamen (neostriatum).

The globus pallidus (pallidum) is the final efferent-cell station of the basal ganglia, its activity being

influenced by inputs from the cortex, striatum, substantia nigra, and subthalamic nucleus. The principal efferent pathway from the pallidum passes rostrally via the ventrolateral nucleus of the thalamus and caudally via the subthalamic and red nuclei. It plays a vital role in initiating movement.

The Principal Connections of the Basal Ganglia

1. From the cerebral cortex to the striatum and from there to the pallidum. From the pallidum fibres pass to the thalamus (nucleus ventralis anterior and nucleus ventralis lateralis) and from here back to the motor cortex.
2. Efferent pathways connect the pallidum with the subthalamic nucleus and substantia nigra.
3. A pathway exists from the substantia nigra to the striatum.

Signs of Extrapyramidal Lesions

Sign	Site of lesion
Resting tremor	Substantia nigra, red nucleus
Muscular rigidity	Substantia nigra, putamen
Hypokinesia	Substantia nigra, globus pallidus, putamen
Chorea	Caudate nucleus
Hemiballismus	Subthalamic nucleus
Dystonia, athetosis	Putamen

The Neuromuscular System (Lower Motor Neurons)

The cell bodies of the lower motor neurons lie in the motor nuclei of the brainstem and in the anterior horns of grey matter of the spinal cord.

The lower motor neuron constitute nerve fibres from cranial nerve nuclei and anterior horn cells till the motor end plate of the muscles they supply.

The Motor Unit

The motor unit consists of spinal anterior horn cell (or cranial nerve motor nuclei), its motor axons and the muscle fibres that the motor axons innervate.

A single axon innervates about 50 to 200 muscle fibres in different muscles. The muscle fibres innervated by a single anterior horn cell and its axon forms a muscle fasciculus. The activity of motor units is controlled by both local spinal reflex arc and by the descending tracts from the cerebrum, extra pyramidal system and cerebellum.

The anterior horn cells in the spinal cord are of two types. The larger alpha cells give rise to nerve fibres

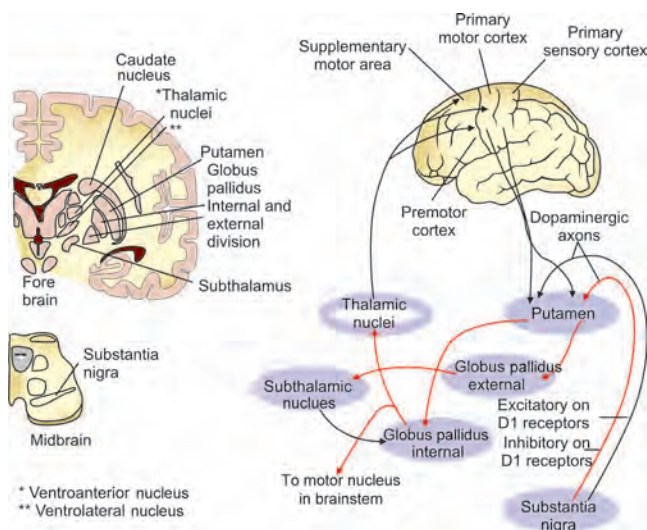

Fig. 8.43: Basal ganglia and its connections



that innervate the muscle fibres and the smaller γ cells that send efferents to the muscle spindles.

Signs of Motor Unit or Lower Motor Neuron Lesion

1. Wasting of the affected muscles.
2. Hypotonia.
3. Weakness or paralysis of muscles supplied by the affected anterior horn cells or axons.
4. Fasciculation in the affected muscle groups (fasciculation is a sign of degenerating anterior horn cells or irritative lesions of the nerve roots or peripheral nerves).
5. Flexor/absent plantar response.
6. Reduced or absent deep tendon reflexes.

The spinomotor system is examined methodically in the following order:

1. Nutrition (bulk of the muscles)
2. Tone
3. Power
4. Coordination
5. Involuntary movements
6. Gait
7. Reflexes.

Nutrition

- The nutrition of the muscles of the shoulder girdles, upper arms, forearms, hands, hip girdles, thighs, calves and feet are noted, the aim being to detect wasting or hypertrophy.
- Note is also made as to the distribution of the nutritional change (predominantly proximal or distal or both proximal and distal).
- Change in nutrition of muscle groups can best be detected by comparing with its fellow on the normal side.
- Circumference of the limbs is measured at the following levels
 - a. In the upper limbs
 - i. 10 cm above the olecranon
 - ii. 10 cm below the olecranon
 - b. In the lower limbs
 - i. 18 cm above the superior border of the patella
 - ii. 10 cm below the tibial tuberosity
- Nutrition of the muscle can also be assessed by palpating the muscle groups affected.
 - a. Atrophic muscle group feels flabby
 - b. Hypertrophic muscle group feels firm or rubbery (due to excessive deposition of fat).

Hypertrophy of the muscle may be physiological (muscles are big and powerful and have a normal consistency), or may be pathological as in pseudo-

hypertrophy of muscular dystrophy (muscles preferentially involved are the calves, buttocks, thighs and shoulder girdles, the muscles are abnormally globular and have a rubbery consistency).

Types of Muscle Wasting

Muscle wasting is usually a sign of lower motor neuron lesion or primary muscle disease.

Generalised Wasting

Generalised wasting of the muscles are seen in the following conditions:

- a. Advanced systemic illness (CVS, RS, Renal, IDDM)
- b. Thyrotoxicosis
- c. Malignancy
- d. Advanced stages of crippling neurological diseases (motor neuron disease; muscular dystrophies).

Muscle Wasting in Upper Limbs

1. Predominantly Proximal Muscle Wasting

- a. Spinal muscular atrophy
- b. Motor neuron disease
- c. Syringomyelia
- d. Compressive lesion at C₅-C₆ level (cervical spondylosis)
- e. Lesion of upper brachial plexus (Erb's paralysis)
- f. Late stages of muscular dystrophies (facioscapulohumeral dystrophy, proximal limb girdle dystrophy, Duchenne type of muscle dystrophy, dystrophia myotonica)
- g. Inflammatory muscle disease (neuralgic amyotrophy, poliomyelitis, polymyositis).

Proximal muscle wasting and weakness are signs of primary muscle disease except myotonic dystrophy, mitochondrial myopathy, inclusion body myositis and distal muscular dystrophy of Gower.

2. Predominantly Distal Muscle Wasting

- a. Motor neuron disease
- b. Syringomyelia
- c. Cervical cord tumours (affecting segmental levels C₈, T₁)
- d. Lesion of lower brachial plexus (Klumpke's paralysis)
- e. Cervical ribs
- f. Cervical glandular enlargement
- g. Pancoast syndrome (superior pulmonary sulcus tumour)
- h. Traumatic lesions of the radial, median and ulnar nerves



- i. Peroneal muscular atrophy (Charcot-Marie-Tooth syndrome or hereditary sensory motor neuropathy Types I and II)
- j. Peripheral neuropathies.

Distal muscle wasting and weakness are signs of peripheral neuropathy except porphyric neuropathy, diabetic amyotrophy and Guillain-Barré syndrome.

3. Both Proximal and Distal Muscle Wasting

- a. Motor neuron disease
- b. Syringomyelia.

Small Muscle Wasting of the Hand (C₈, T₁) (Fig. 8.44)

1. Vertebral lesions
 - a. Craniovertebral anomalies
 - b. Vertebral metastasis
2. Spinal cord lesion
 - a. Syringomyelia
 - b. Cord compression by tumour
3. Anterior horn cell lesion
 - a. Motor neuron disease
 - b. Poliomyelitis
 - c. Spinomuscular atrophy
4. Root lesions
 - a. Cervical spondylitis (rare)
 - b. Cervical cord tumour
 - c. Cervical hypertrophic pachymeningitis
 - d. Pancoast tumour
 - e. Peroneal muscular atrophy
 - f. Cervical disc prolapse
5. Brachial plexus lesion
 - a. Cervical rib



Fig. 8.44: Small muscle wasting

- b. Klumpke's paralysis (avulsion of lower brachial plexus)
6. Peripheral nerve lesion
 - a. Hansen's disease (predominantly hypothenar)
 - b. Carpal tunnel syndrome (predominantly thenar)
 - c. Lead poisoning (wrist drop)
 7. Muscle diseases
 - a. Distal muscular dystrophy
 - b. Polymyositis
 - c. Myotonia
 - d. Distal myopathy of Gower
 8. Disuse atrophy
 - a. Therapeutic immobilisation (fracture)
 - b. Arthritic (rheumatoid arthritis)
 - c. Post-paralytic (hemiplegia)
 - d. Volkmann's ischaemic contracture (tight, improper, plaster application).

Muscle Wasting in Lower Limbs

Isolated wasting of muscles in the lower limb is less common than in the upper limbs. The wasting usually occurs in combination with that of the upper limb.

Conditions producing wasting in the lower limbs are:

- a. Cauda equina lesion
- b. Peripheral neuropathy
- c. Peroneal muscular atrophy (Charcot-Marie Tooth syndrome or hereditary sensory motor neuropathy types I and II)
- d. Poliomyelitis
- e. Peripheral nerve trauma (lateral popliteal nerve)
- f. Tarsal tunnel syndrome.

Conditions producing wasting, in both upper and lower limbs

- a. Peroneal muscular atrophy (Charcot-Marie-Tooth syndrome or hereditary sensory motor neuropathy types I and II)
- b. Chronic polyneuropathy
- c. Spinal muscular atrophy (Werdnig-Hoffman's disease in childhood; later stages of Kugelberg-Welander syndrome)
- d. Distal myopathy of Gower
- e. Hansen's disease.

Tone

Tone of a muscle is defined as the degree of tension present in a muscle at rest.

Tone may be normal, increased, or decreased. Increased tone is known as *hypertonia*. Decreased tone is known as *hypotonia* (Fig. 8.45).

An important point to be kept in mind while testing the tone of the muscle is that the patient must be

Unilateral Muscle Wasting		Bilateral Muscle Wasting
Thenar	Hypothenar	Both
1. Carpal tunnel syndrome	1. Hansen's disease	1. Brachial plexus injury
2. Hansen's disease	2. Ulnar nerve injury	2. Pancoast tumour
3. Median nerve injury		3. Cervical rib
		4. Cervical cord lesions

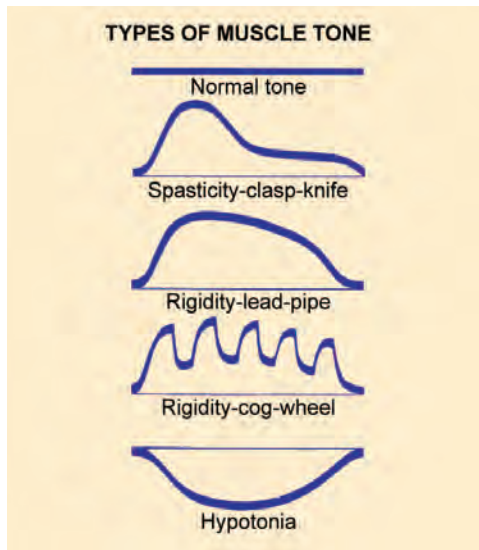

Fig. 8.45: Types of muscle tone

comfortable, relaxed and exude confidence in the examiner. An accurate assessment of the tone can be made when these criteria are satisfied.

Tone can be assessed by inspection and palpation of the muscle group and by passive movement at the various joints.

Tone assessment in a stuporose or unconscious patient can be done by raising each arm in turn and allowing it to fall back on the bed. The checking movement occurring in order to break the fall is compared on both sides. On the side of hypotonia, the limb falls to the bed, as if lifeless.

Hypertonia

On inspection, the muscle groups, which exhibit hypertonia, are seen to stand out prominently with increased convexity of the muscle bellies.

On palpation, the hypertonic muscle groups are firm in consistency.

There is resistance felt on passive movements of the joints, either in the form of *spasticity* or *rigidity* (Fig. 8.45).

Spasticity

It is a state of hypertonia of the agonist and antagonist muscle groups. Hypertonia however is more in one of these muscle groups (antigravity muscle group), producing a clasp-knife type of spasticity (e.g. in cases of hemiplegia, the tone in the flexor group of muscles exceeds that of the extensor group in the upper limb and vice versa in the lower limb).

Spasticity is a sign of pyramidal system lesion (upper motor neuron lesion).

Rigidity

It is a state of hypertonia in which tone is uniformly increased in both the agonist and antagonist group of muscles.

Rigidity is a sign of extrapyramidal system lesion.

Rigidity is of two types (Fig. 8.45)

- Plastic or lead pipe rigidity* (uniform resistance offered to passive movement). This type of rigidity is seen in
 - Parkinsonism (post-encephalitic)
 - Basal ganglia neoplasms
 - Catatonia.
- Cog wheel rigidity* (resistance offered to passive movement interrupted by alternate contractions of the agonist and antagonist muscles due to presence of associated tremor). This type of rigidity is seen in
 - Parkinson's disease
 - Overdosage with reserpine or chlorpromazine
 - Carbon monoxide poisoning.

Hysterical rigidity: In this type of rigidity, seen in hysterical patients, the resistance to passive movement increases in proportion to the effort applied by the examiner.

Gegenhalten phenomenon: It may be seen in a few cases of corticospinal and extrapyramidal disorders. There is stiffening of the limb in response to contact and a resistance to passive changes in position and posture.



Differentiation between Spasticity and Rigidity

Spasticity	Rigidity
It is a sign of pyramidal tract lesion	It is a sign of extrapyramidal tract lesion
Tone is more in the anti-gravity group of muscles than in the gravity assisted group of muscles	Tone is equally raised in the gravity assisted and anti-gravity group of muscles
Clasp knife type of spasticity	Lead pipe or cog wheel type of rigidity
Spasticity is velocity dependent (spasticity is better appreciated when passive movement of the joint is carried out rapidly)	Rigidity is not velocity dependent
Abdominal reflexes are lost	Abdominal reflexes are preserved
Plantar is extensor (Babinski's sign)	Plantar is flexor
Deep tendon reflexes are brisk or exaggerated	Deep tendon reflexes are normal or decreased
There may be associated sustained clonus	Clonus is absent

Hypotonia

- On inspection, the muscle groups, which exhibit hypotonia, are lax and assume a pendulous shape when allowed to hang freely.
- On palpation, the hypotonic muscle groups are flabby to feel.
- There is diminished resistance to passive movement of the joints, thus widening the range of movement at the joint.



Causes of Hypotonia

1. Lesions of the motor side of the reflex arc
 - a. Poliomyelitis

- b. Polyneuritis
 - c. Peripheral nerve injuries
2. Lesions of the sensory side of the reflex arc
 - a. Tabes dorsalis
 - b. Herpes-zoster
 - c. Carcinomatous neuropathies
 3. Combined motor and sensory lesions
 - a. Syringomyelia
 - b. Cord or root compression
 - c. Gross cord destruction
 4. Lesions of the muscle (myopathies)
 5. State of spinal shock in upper motor neuron lesion
 6. Cerebellar lesions
 7. Chorea
 8. Periodic paralysis (potassium disorders)
 9. REM sleep
 10. Benzodiazopine overdose, neuromuscular blockers.

Clonus

Sudden stretching of hypertonic muscles produces reflex contraction. If the stretch is maintained during the subsequent relaxation, further reflex contraction occurs and this may continue almost indefinitely, unless the stretch stimulus is released.

It is most easily demonstrated by dorsiflexing the foot, after flexing the hip and the knee (ankle clonus) or by sharply moving the patella downwards (patellar clonus) (Fig. 8.46).

Sustained clonus is a sign of *pyramidal tract lesion* (upper motor neuron lesion).

Ill-sustained clonus may be seen in very tense people, after straining (e.g. after defaecation), or one who has had a recent frightening experience.

Ill sustained clonus - < 6 downward beats of the foot.



Ankle clonus—correct method



Incorrect method—do not catch the calf muscles

Fig. 8.46: Ankle clonus



Fig. 8.47: Patellar clonus

Sustained clonus and at times even the ill-sustained clonus > 6 are significant and denote pyramidal lesion.

The muscles must be palpated and percussed to assess the following (Fig. 8.47):

- The muscle groups are palpated to elicit tenderness. Tenderness of muscle group is elicited in inflammatory muscle disorders (polymyositis).
- Percussion of muscle groups, especially over the thenar eminence and extensor group of muscles of the forearm and over the tongue, produces a dimpling of the muscle, which remains for some time. This is a feature of myotonia.

Myotonia

This is a state in which muscle contraction continues beyond the period of time required for a particular movement to be made.

It is best seen in the face and hand muscles.

When the patient is asked to smile and then relax his facial muscle, a delay in relaxation of the muscle is noted and the smile remains fixed on the face for a longer duration (*transverse smile*).

Similarly when the patient is asked to grip the examiner's fingers and then let go immediately, a delay in the relaxation of the grip is noted.

Conditions Causing Myotonia

- a. Myotonic dystrophy
- b. Myotonia congenita
- c. Paramyotonia congenita (myotonia occurs on exposure to cold).

Power

Muscle power is the force of contraction that can be generated voluntarily by the muscle.

Muscle power is tested in the different muscle groups, from head to foot.

Any weakness detected is noted and analysed by comparing with the power of the similar group of muscles on the normal side.

Note is made as to the predominant groups of muscles involved (proximal, distal or both proximal and distal). The causes of predominant proximal muscle weakness, predominant distal muscle weakness or both proximal and distal muscle weakness are the same as listed for muscle wasting.

The quantitative assessment of power can be done by grading the muscle power as suggested by the Medical Research Council.

Grade 5 Normal power.

Grade 4 Movement against resistance.

Grade 3 Movement against gravity.

Grade 2 Gravity eliminated movement (lateral movements in bed).

Grade 1 There is a visible or palpable flicker of contraction, but no resultant movement of joint.

Grade 0 Total paralysis.

Grade 4 power covers a broad range – (4–, 4, and 4+) denoting movement against slight, moderate and stronger resistance.

Normally, the larger the muscle group, the greater is the power exhibited by that muscle group. Exceptions to this rule are seen in the following:

- a. The power of the muscles of mastication (small muscles) is greater than the power of the pectoral muscles (large muscles).
- b. The power in muscular dystrophies is weak, in spite of their larger size (pseudohypertrophy).
- c. Some amount of muscle power is retained in spite of the muscle wasting seen in motor neuron disease.

Coordination

Coordination of the limbs can be tested effectively only when the power of the muscle is greater than grade 3.

It is always better to explain the procedure properly to the patient so that the patient can perform the act smoothly.

The limbs are examined on both sides and the results compared.

All tests for coordination are done initially with eyes open and then with eyes closed (to detect posterior column lesions).

Coordinated action of the muscles is under cerebellar control, and influenced by the extrapyramidal system. Intact proprioceptive sense, combined with an accurate



Testing of Muscle Power of Different Muscles

<i>Muscle</i>	<i>Main segmental nerve supply</i>	<i>Peripheral nerve</i>	<i>Test</i>
Muscles of the neck	Eleventh cranial nerve	Spinal accessory nerve	Patient is asked to flex his neck against resistance
a. Sternocleidomastoids			
b. Nuchal muscles	C _{2,3}	Occipital nerve	Patient is asked to extend his neck against resistance
Deltoid	C ₅	Circumflex	The patient holds his arm abducted to 60° against the examiner's resistance
Supraspinatus	C ₅	Suprascapular	The patient tries to initiate abduction of the arm from the side against resistance
Infraspinatus	C ₅	Suprascapular	The patient flexes his elbow, holds the elbow to his side, and then attempts to turn the forearm backwards against resistance
Rhomboids	C ₅	Nerve to rhomboids	Hand on hip, the patient tries to force his elbow backwards
Serratus anterior	C _{5,6,7}	Nerve to serratus anterior	The patient pushes his arms forwards against the wall
Pectoralis major	C _{6,7,8}	Lateral and medial pectoral nerves	Placing the hand on the hip and pressing inwards; the sternocostal part of the muscle can be felt to contract. Raising the arm forwards above 90° and attempting to adduct it against resistance brings the clavicular portion into action
Latissimus dorsi	C ₇	Nerve to latissimus dorsi	a. While palpating the muscles ask the patient to cough b. Resist the patient's attempt to adduct the arm when abducted to above 90°
Biceps	C ₅	Musculocutaneous	The patient flexes his elbow against resistance, the forearm being supinated
Brachio-radialis	C _{5,6}	Radial	The patient pronates the forearm and draws the thumb towards the nose against resistance
Triceps	C ₇	Radial	The patient attempts to extend the flexed elbow against resistance
Extensor carpi radialis longus and extensor carpi ulnaris	C _{6,7}	Radial	The patient attempts to dorsiflex his wrist against resistance
Flexor carpi radialis and flexor carpi ulnaris	C _{6,7,8}	Median and ulnar	The patients attempts to flex his wrist against resistance
Abductor pollicis longus	C ₈	Radial	The patient attempts to maintain his thumb in abduction against the examiner's resistance
Extensor pollicis brevis	C ₈	Radial	The patient attempts to extend the thumb while the examiner attempts to flex it at the metacarpophalangeal joint
Extensor pollicis longus	C ₈	Radial	The patient attempts to extend the thumb while the examiner attempts to flex it at the interphalangeal joint
Flexor pollicis longus	C ₈	Median	Attempt is made to flex the distal phalanx of the thumb against the patient's resistance
Opponens pollicis	T ₁	Median	The patient attempts to touch the little finger with the thumb. Preserved in ulnar nerve lesions when the rest of the hand appears very wasted
Adductor pollicis brevis	T ₁	Median	An object is placed in between the thumb and forefinger to prevent full adduction; then the patient attempts to raise the edge of the thumb vertically above the starting point, against resistance. This is an important muscle, being the first to show weakness in carpal tunnel syndrome
Adductor pollicis	T ₁	Ulnar	The patient attempts to hold a piece of paper between the thumb and the palmar aspect of the forefinger
Lumbricals and interossei	C ₈ T ₁	Median (lumbricals I and II); ulnar (lumbricals III and IV and interossei)	a. The lumbricals are tested by asking the patient to flex the extended fingers at the metacarpophalangeal joints b. The dorsal interossei are tested by asking the patient to abduct the fingers against resistance. The palmar interossei are tested by asking the patient to grip a piece of paper with his adducted fingers

Contd...



Contd...

Muscle	Main segmental nerve supply	Peripheral nerve	Test
Flexor digitorum sublimis	C ₈	Median	The patient flexes the fingers at the proximal interphalangeal joint against resistance from the examiner's fingers placed on the middle phalanx
Flexor digitorum profundus	C ₈	Median and ulnar	The patient flexes the terminal phalanx of the fingers against resistance, the middle phalanx being supported
Abdominal muscles	T ₆ -T ₁₂	Ilioinguinal, iliohypogastric	The patient lies on his back and attempts to raise the head against resistance. Note is made of the movement of the umbilicus. In case of lower abdominal muscle weakness, the umbilicus is pulled upwards by the healthy upper abdominal muscles. It is pulled downwards in presence of upper abdominal muscle weakness. In case of lesion at the level of T ₁₀ spinal segment, the umbilicus moves up by at least 3 cm on contracting the abdominal muscles
Erector spinae muscle	All segments	Posterior rami of spinal nerves	The patient lies prone and then attempts to raise his shoulders off the bed
Ilio-psoas	L _{1,2,3}	Femoral	The patient lies on his back and attempts to flex his thigh against resistance
Adductor longus	L _{2,3}	Obturator	The patient attempts to adduct the leg against resistance
Gluteus medius and minimus	L ₄ -S ₁	Superior gluteal	The patient, lying prone, flexes the knee and then forces the foot outwards against resistance. These muscles also abduct the extended leg
Gluteus maximus	L ₅ , S ₁	Inferior gluteal	The patient lying prone, should tighten the buttocks so that each can be palpated and compared; then he is instructed to try to raise the thigh against resistance
Hamstrings (biceps, semitendinosus, semimembranosus)	L _{4,5} S _{1,2}	Sciatic	The patient lying prone, attempts to flex the knee against resistance
Quadriceps femoris	L _{3,4}	Femoral	The patient, lying on his back, attempts to extend the knee against resistance
Tibialis anterior	L _{4,5}	Anterior tibial	The patient dorsiflexes his foot against the resistance of the examiner's hand placed across the dorsum of the foot
Tibialis posterior	L ₄	Medial popliteal	The patient plantar-flexes the foot slightly and then tries to invert it against resistance
Peronei	L ₅ S ₁	Musculocutaneous	The patient everts the foot against resistance. Isolated weakness may be the earliest sign of peroneal muscular atrophy
Gastrocnemius	S ₁	Medial popliteal	The patient plantar flexes the foot against resistance
Extensor digitorum longus	L ₅	Anterior tibial	The patient dorsiflexes the toes against resistance
Extensor hallucis longus	L ₅	Anterior tibial	The patient attempts to dorsiflex the great toe against resistance
Flexor digitorum longus	S _{1,2}	Medial popliteal	The patient flexes the terminal phalanges of the toes against resistance

image of one's own body and its relationship to the environment are equally essential for the movement to be completed satisfactorily. Lesions in these sites may therefore produce incoordination.

Methods of Testing Coordination

1. Testing Coordination in the Upper Limbs

- The finger-nose test:* In this test, the patient is asked to keep his upper limb outstretched and then to touch the tip of his nose with his forefinger. This act is repeated and the ability to carry out this action smoothly is noted and compared with the opposite limb (Fig. 8.48).
- The finger-finger-nose test:* This test is performed in a similar manner as the finger-nose test, except that the patient is asked to touch the examiner's finger before touching his nose. This test helps to detect mild degrees of incoordination (Fig. 8.49).
- Tapping in a circle test:* A circle 1 cm in diameter is drawn and the patient is given a pencil and asked to tap out a series of dots, all within the circle. In any ataxia, the patient will spread the dots irregularly over a wide area, outside as well as inside the circle.



Correct method-Testing with arm in abducted position

Incorrect method

Fig. 8.48: Finger-nose test



Fig. 8.49: Finger-finger-nose test



Fig. 8.50: Heel-knee test

- d. *Dysdiadochokinesis*: This is a failure to efficiently perform rapidly alternating movements. This test may be carried out by asking the patient to alternatively and rapidly pronate and supinate the forearm and hand while clapping the other hand. In presence of incoordination, this alternating rapid movement cannot be carried out smoothly.

2. Testing Coordination in the Lower Limbs

- The heel-knee test*: The patient is asked to place the heel of one foot over the knee of the other foot and then to move the heel down over the tibia. This test is repeated with the other foot and presence or absence of incoordination is noted (Fig. 8.50).
- Foot pat test*: The patient is asked to pat the ground with the heels of both feet alternatively in the sitting position. In presence of incoordination this test cannot be carried out smoothly (Fig. 8.51).

The failure to demonstrate in-coordination when the patient is lying in the bed does not exclude cerebellar



Fig. 8.51: Testing coordination in lower limbs (method 2)



disease. Gross ataxia of the gait may be the only physical sign in a midline posterior fossa lesion or cerebellar vermis lesion or lesions due to displacement of cerebellar tonsils through the foramen magnum (Chiari deformities).

Involuntary Movements

A note is made as to the presence of involuntary movements.

They may be grossly visible (dystonias) or may require careful examination to detect their presence (e.g. muscle fasciculation).

They may be seen at rest or may become manifest when the patient assumes certain postures or when he walks.

They are mainly due to lesions affecting the extra-pyramidal system.

Common Involuntary Movements

Chorea (Caudate Nucleus)

This is described as a semi-purposive, irregular, non-repetitive and brief, jerky movements arising in the proximal joints and appearing to flit from one part of the body to another randomly. The movements are absent during sleep, and increased on attempting voluntary movement. Emotional disturbance exacerbates this involuntary movement. It is due to lesion in the caudate nucleus.



Causes of Chorea

- Sydenham's chorea
- Chorea gravidarum
- Huntington's chorea
- Hereditary chorea
- Hemichorea
 - Stroke
 - Tumour
 - Trauma
 - Post-thalamotomy
- Drug induced chorea
 - Neuroleptic drugs
 - Phenytoin
 - Alcohol
 - Contraceptive pill
- Symptomatic chorea
 - Encephalitis lethargica
 - Subdural haematoma
 - Cerebrovascular disease
 - Neuroacanthocytosis
 - Dentato-rubro-pallido-luysian degeneration

- Hypoparathyroidism
- Hypernatraemia
- Polycythaemia rubra vera
- SLE
- Antiphospholipid antibody syndrome
- Thyrotoxicosis.

Chorea may be seen in the following conditions:

- a. Sydenham's chorea (usually children, often with a history of rheumatic fever).
- b. Huntington's chorea (autosomal dominant condition affecting patients in middle life, associated with progressive dementia).
- c. Chorea of pregnancy (usually with first pregnancy).
- d. Chorea in patients on oral contraceptives.
- e. Senile or arteriosclerotic chorea (occurs in the elderly, with sudden onset and with other evidence of degenerative vascular disease).
- f. Chorea in primary polycythaemia.

Huntington's chorea is associated with hypertonia unlike other choreas in which there is hypotonia.

Signs elicitable in chorea

1. Involuntary protrusion and retraction of the tongue ("Jack in the box" tongue).
2. Respiratory irregularity.
3. Hypotonia and hyperextensibility of the joints.
4. Inability to hold the hands above the head with palms facing each other as it results in pronation of the forearm and the palm faces outwards (*Pronator sign*).
5. *Milk maid sign* can be elicited on asking the patient to grasp the examiner's fingers with the affected hand. A milking action is perceived by the examiner.
6. *Hung up reflex* can be seen on eliciting the knee jerk. The knee extends and the leg and foot hangs up in mid air due to the involuntary choreic movement.

Athetosis (Putamen)

This is a slow writhing movement, best seen at wrists, fingers and ankles. The fingers writhe, the wrists flex, the forearm and arm rotate inwards, adduct, and then rotate outwards in abduction. The foot is inverted. The movements are absent during sleep, minimally altered by eye closure, increased by voluntary movement, and interfering with it.

Hemiballismus (Subthalamic Nucleus)

It is the most dramatic of all involuntary movements. It usually affects the proximal joint of one arm resulting in wild, rapid, flinging movement of wide radius, occurring constantly, interspersed with short periods of freedom. The movements may be sufficiently violent so as to injure the patient or the bystanders. It is absent during



sleep, but may prevent sleep because of their violent nature. It may be accompanied by increased tone and reflexes in the affected limb. It is due to a lesion in the subthalamic nucleus.

Dystonias (Putamen)

Idiopathic (or primary) torsion dystonia is a disorder characterised by involuntary sustained muscle contractions frequently causing twisting and repetitive movements (along the long axis of the arm—axial rotation) or abnormal postures without other associated neurological features.

Types of Dystonias

- Dystonia affecting the whole body (generalised dystonia or dystonia musculorum deformans) is common in children.
- Dystonia affecting adjacent parts of the body such as an arm and neck (segmental dystonia).
- Dystonia restricted to a single body part (focal dystonia) is common in adults. Focal dystonias include spasmodic torticollis, blepharospasm, oromandibular dystonia, spasmodic dysphonia, and dystonic writer's cramp.

Causes of Dystonia

Primary generalised dystonia (Autosomal dominant-Chromosome 9)

Focal adult-onset dystonia (Autosomal dominant-Chromosomes 8 and 18)

- Blepharospasm
- Oromandibular dystonia
- Cranial dystonia
- Spasmodic torticollis
- Axial dystonia
- Writer's/occupational cramps

Dystonia plus syndromes

- Dopa-responsive dystonia (Autosomal dominant-Chromosome 14)
- Myoclonic dystonia (Autosomal dominant-Chromosome 18)

Heredito-degenerative dystonias

- Ataxia telangiectasia
- Lipid storage diseases and leukodystrophies
- Mitochondrial encephalopathies
- Leigh's disease
- Wilson's disease
- Juvenile Huntington's disease
- Neuroacanthocytosis
- Parkinson's disease

- Steele-Richardson-Olszewski disease
- Multiple system atrophy
- Autosomal dominant cerebellar ataxias

Symptomatic dystonia

- Athetoid cerebral palsy
- Cerebral anoxia
- Post-encephalitic dystonia

Drug induced dystonia

- Neuroleptics
- Mn poisoning
- Levodopa
- Other toxins

Hemidystonia

- Stroke
- Tumour
- AV malformations
- Trauma
- Encephalitis—Post-thalamotoms

Paroxysmal dystonia (paroxysmal choreo-athetosis)

- Paroxysmal exercise induced dystonia
- Paroxysmal kinesigenic choreo-athetosis
- Paroxysmal dystonic choreo-athetosis.

Tremors

Tremor is defined as a rhythmical and oscillatory movement of a body part caused by regular, rhythmical, contractions of the agonist and antagonist muscles.

Tremors may be fine (thyrotoxicosis) or coarse (alcoholism). A fine tremor is one that is visible only on close inspection and best brought out by balancing a piece of paper on the patient's outstretched fingers. A coarse tremor is one which is very obvious and needs no special measures to see it.

Tremors are subdivided according to when they occur.



Causes of Tremors

Rest tremor

- Parkinson's disease
- Post-encephalitic parkinsonism
- Drug induced parkinsonism
- Other extrapyramidal diseases

Postural tremor

- Physiological tremor
- Thyrotoxicosis
- Anxiety states
- Alcohol, caffeine
- Drugs



- Sympathomimetics
- Antidepressants
- Lithium
- Sodium valproate
- Heavy metal poisoning (mercury)
- Structural brain disease
 - Severe cerebellar lesions
 - Wilson’s disease
 - Neurosyphilis
- Benign essential (familial) tremor

Intentional tremor

- Lesions of cerebellum and its connections
 - Multiple sclerosis
 - Spinocerebellar degenerations
 - Vascular disease
 - Tumour

Primary writing/task specific tremor

Dystonic tremor.

Types of Tremors

- a. *Rest tremor* (static tremor) occurs when the limb is at rest (e.g. tremor seen in Parkinson’s disease).
- b. *Action tremor* refers to tremors present when the limbs are active. It can be present throughout the range of voluntary movements or when the limbs are maintained in a particular position when it is known as postural tremor.
- c. *Postural tremor* occurs when the limb maintains a posture such as holding the arms and hands outstretched (e.g. essential familial tremor; tremors seen in thyrotoxicosis).
- d. *Intention tremor* occurs when the limb approaches its target. It is not a true tremor since it involves the whole limb (e.g. tremors in cerebellar lesion).
- e. *Perioral tremor* is a constant coarse tremor of the orbicularis oris and chin, usually seen in general paresis of insane.

Classification of Tremors

Type	Frequency (Hz)	Predominant location
Physiologic	8–13	Hands
Parkinson	3–5	Hands, forearms, fingers, feet, lips and tongue
Cerebellar	2–4	Limbs, trunk and head
Postural	5–8	Hands
Essential	4–8	Hands, head & vocal cord
Tremor of neuropathy	4–7	Hands
Palatal myoclonus	1–2	Soft palate

Common conditions producing tremors

- a. Nervousness and anxiety states
- b. Thyrotoxicosis
- c. Alcoholism
- d. Essential herido-familial tremor
- e. Parkinsonian tremor
- f. Cerebellar lesions
- g. Wilson’s disease
- h. Benedict’s syndrome (due to involvement of the red nucleus)
- i. Hepatic failure, renal failure, respiratory failure (flapping tremor or asterixis).

Myoclonus

This consists of rapid, brief shock like muscle jerks which are often repetitive and sometimes rhythmical. Myoclonic jerks may be a normal phenomenon occurring just as the patient falls asleep or may be a manifestation of a major seizure disorder.



Causes of Myoclonus

Generalised Myoclonus

- Progressive myoclonic encephalopathies
- Hereditary myoclonus
- Myoclonus associated with spinocerebellar degeneration
- Metabolic cause—Tay-Sachs and Batten’s disease
- Encephalitis lethargica
- Subacute sclerosing leukoencephalitis
- Cruetzfeldt-Jakob disease
- Alzheimer’s disease

Metabolic myoclonus

- Uraemia
- Hyponatraemia
- Hypocalcaemia
- Hepatic failure
- CO₂ narcosis

Drug induced myoclonus

- Alcohol and drug withdrawal
- Post-traumatic myoclonus
- Benign essential (familial) myoclonus
- Myoclonic epilepsies

Focal/Segmental myoclonus

- Spinal tumor/infarct/trauma
- Palatal myoclonus
- Hemifacial spasm
- Cortical reflex myoclonus
- Epilepsia partialis continua.



Tics

These are repetitive irregular stereotyped movements or vocalisations which can be imitated. They can usually be suppressed.

Tics are often more pronounced when the patient is relaxed and not consciously suppressing them, in contrast to most other dyskinesias which are more marked under stress and tend to be less marked with relaxation.



Causes of Tics

Simple tic

- Transient tic of childhood
- Chronic simple tic

Complex multiple tics

- Chronic multiple tics
- Gilles de La Tourette syndrome

Symptomatic tics

- Encephalitis lethargica
- Drug induced tics
- Post-traumatic
- Neuroacanthocytosis
- Focal brain lesions.

Fasciculation

This term is applied to an irregular, non-rhythmical contraction of muscle fascicles. They are best seen in large muscles such as deltoid or calf muscles. They are present at rest and may be increased after voluntary movement. It is a sign of lower motor neuron lesion, and especially a sign of active degeneration of the anterior horn cells or irritative lesions of the nerve roots or peripheral nerves. Fasciculation, if not seen at rest, may be brought about by contracting the muscle, hyperventilation or by cooling the muscle with ethyl chloride spray.

Conditions causing fasciculation

- Motor neuron disease
- Syringomyelia
- Cervical spondylosis
- Primary muscular atrophy
- Peroneal muscular atrophy
- Poliomyelitis (in the recovery phase)
- Thyrotoxic myopathy
- Carcinomatous myopathy
- Organophosphorous poisoning
- Administration of edrophonium or neostigmine
- Benign.

Presence of fasciculation excludes myopathy except thyrotoxic and carcinomatous myopathies.

Fibrillation

These are contraction of individual muscle fibres occurring as a result of denervation hypersensitivity. This abnormal movement cannot be seen in muscles which are covered with subcutaneous tissue and skin. They can however be perceived over the tongue, where they can be easily seen under the thin mucous membrane.

Myokymia

These are the most common involuntary movements of the muscles seen as a fine or coarse very rapid rippling movement of muscle fibres, persisting in the same group of fibres for minutes at a time. The most common myokymia is that involving the orbicularis oculi.

Fibrillation single muscle fibre

Fasciculation single muscle fascicles

Myokymia bundle of muscle fascicles.

Minipolymyoclonus

In cases where there is chronic denervation of muscles (motor neuron disease) and reinnervation, involving many fascicles, an involuntary tremor like movement of the joints, especially of the small joints of the hands is seen and is termed minipolymyoclonus.

Titubation

It is the involuntary nodding of the head seen in lesions of the vermis of the cerebellum.

Gait

The gait of the patient may give a clue to the neurological condition.

The patient may be asked to walk in a straight line for at least 9 metres and then turn and walk back to the starting point.

Note is made of the posture of the body while walking, the position and movement of the arms, the relative ease and smoothness of movement of the legs, the distance between the feet both in forward and lateral directions, the regularity of the movement, the ability to maintain a straight course, the ease of turning and, finally, of stopping.

Abnormalities of Gait

Circumduction Gait (Hemiplegic Gait)

This type of gait is seen in hemiparesis. The patient throws his lower limb outwards, the movement occurring at the hip joint, producing the movement called circumduction and leaning towards the opposite healthy side.



The affected arm is adducted at the shoulder and flexed at the elbow, wrist and fingers.

Spastic Gait (Bipyramidal Lesion)

This type of gait is seen in lesions of the upper motor neuron involving both the lower limbs. There is an adductor spasm causing the legs to cross each other and each foot trips the other. When the adductor spasm is marked, as seen in cerebral diplegia, the gait is known as scissors gait. The movements are slow and stiff. The steps are short with the feet scraping the floor.

High Stepping Gait (Foot Drop)

This type of gait is seen in patients with foot drop. The patient raises the foot high in order to overcome the foot drop and on keeping the foot down the toe hits the ground first. There is no ataxia.

High Stepping and Stamping Gait (Posterior Column Lesion)

This type of gait is seen in patients with posterior column lesion, where there is gross loss of position sense. The patient does not know where his foot is and so, on walking raises his foot high up in the air and brings it down on the ground forcefully (stamping), the heel of the foot coming in contact with the ground first. This abnormal gait is more prominent in the dark or when the patient walks with his eyes closed.

Ataxic Gait (Cerebellar Lesion)

This type of gait is seen in patients with cerebellar lesion. The patient is ataxic and reels in any direction, including backwards and walks on a broad base. The patient finds difficulty in executing tandem walking.

Shuffling Gait (Extrapyramidal Lesion)

This type of gait is seen in patients with lesions of the extrapyramidal system, associated with rigidity. The patient makes a series of small, flat footed shuffles. This gait is typically seen in parkinsonism, where the patient has a stooped posture (universal flexion) and walks rapidly with short, shuffling steps, as if trying to catch up with gravity. The automatic associated upper limb movements are absent.

Waddling Gait (Primary Muscle Disease)

This type of gait is seen in patients with proximal muscle weakness of the lower limbs (muscular dystrophy) or with bilateral hip problem (congenital dislocation of the hips). The patient walks on a broad base with an exaggerated lumbar lordosis.

Reflexes

A reflex is a consistent involuntary adaptive response to the stimulation of a sense organ. The components of the reflex arc are:

- i. Sensory receptor
- ii. Afferent pathway
- iii. Centre
- iv. Efferent pathway
- v. Effector organ.

The reflexes to be tested are the superficial reflexes, deep tendon reflexes and visceral reflexes.

The deep tendon reflexes are monosynaptic reflexes and the superficial and visceral reflexes are polysynaptic reflexes.

Stretching of muscle spindle activates spinal afferent fibres and α -motor neurons which results in reflex muscle contraction.

Sherrington's law of reciprocal innervation:

Activation of agonist muscle group is accompanied by inhibition of antagonist muscle group.

The patient must be appraised of the procedure to be adopted in eliciting the various reflexes, as these reflexes can be easily and correctly elicited only in a completely relaxed patient.

The reflexes may be present, lost or exaggerated and thereby give a clue to the underlying neurological problem.

It can also help to localise the level of lesion.

Abdominal Reflexes

Abnormal Responses

Exaggerated abdominal reflexes may be seen in psychoneurosis, or in anxiety states (Fig. 8.52).

Absent abdominal reflexes may be seen in

1. Defects of technique, relaxation, or observation
 2. A breach of the appropriate reflex arc, due to lesions such as herpes-zoster, or scar due to surgical operations which have damaged the peripheral nerves or the muscle itself.
 3. Repeated pregnancies (multigravid woman), in patients with flaccid abdominal muscles, distention of abdomen (ascites, pregnancy or massive organomegaly).
 4. Pyramidal system lesions above the upper level of segmental innervation.
- Abdominal reflexes are lost early in multiple sclerosis.
 - Abdominal reflexes are retained till late in a motor neuron disease, cerebral diplegia, infantile hemiplegia in spite of pyramidal system involvement.



Superficial Reflexes

Reflex	Technique	Segmental innervation	Normal response
Corneal	The corneal edge is touched with a wisp of cotton, with the patient looking in the opposite direction	Afferent: V nerve Centre: pons Efferent: VII nerve	Brisk closure of the eyes
Conjunctival	The bulbar conjunctiva is touched with a wisp of cotton	—do—	—do—
Pharyngeal	The posterior wall of the pharynx is tickled	Afferent: IX nerve Centre: Medulla Efferent: X nerve	Contraction of the pharyngeal muscles
Palatal	The soft palate is tickled	Afferent: V nerve Centre: Medulla Efferent: X nerve	The soft palate moves up
Scapular reflex	Stroking skin in interscapular area	Afferent: C ₄₋₅ Centre: C ₄₋₅ Efferent: Dorsal scapular nerve	Contraction of scapular muscles
Abdominal reflexes	The abdominal wall is lightly stroked from without inwards, stimulating each of the four quadrants of the abdomen	Upper abdomen: T _{7-T₉} Mid abdomen: T _{9,10} Lower abdomen: T _{11,12}	The muscles in quadrants stimulated contract and the umbilicus moves in that direction
Cremasteric reflex (Fig. 8.53)	The upper and inner part of the thigh is stroked in a downward and inward direction	Afferent: Femoral nerve Segment: L _{1,2} Efferent: Genitofemoral nerve	Contraction of the cremasteric muscle pulls up the scrotum and testicle on the side examined
Plantar reflex	The patient is positioned such that the knee is slightly flexed, and the thigh externally rotated. The examiner fixes the ankle joint by holding it and then the outer aspect of the sole is stroked with a blunt point (key). The stroke is directed forwards and then curves inwards along the metatarsophalangeal joints, from the little to the big toe	Afferent: Tibial nerve Segment: L _{5, S_{1,2}} Efferent: Tibial nerve	Normally, the great toe will flex at the metatarsophalangeal joint, accompanied by flexion of the other toes



Do not cross the midline
Fig. 8.52: Method of testing abdominal reflex



Fig. 8.53: Cremasteric reflex



- In hemiplegia, there is unilateral loss of abdominal reflexes on the side of hemiplegia.
- When Beevor's sign is positive, there is upper abdominal muscle contraction and retained upper abdominal reflexes, whereas there is absence of lower abdominal muscle contraction and reflexes (T₁₀ segment lesion).

The Plantar Reflex

Abnormal Responses

Babinski's Sign or Extensor Plantar Response

This response is seen with lesions of the corticospinal tract (pyramidal tract).

On eliciting the plantar response, there is dorsiflexion of the great toe, along with extension and fanning out of the other toes.

In addition, especially if the response is marked, there is dorsiflexion at the ankle, with flexion at the knee and hip, these associated movements being brought about by contraction of the anterior tibial, hamstrings, and tensor fascia lata.

The Babinski's sign can be elicited only by stroking the lateral aspect of the dorsum of foot in presence of minimal pyramidal tract lesion, and in individuals with thick soles.

The Babinski sign can be elicited over the medial aspect of the foot when the lesion becomes dense (due to increase in the reflexogenic area).

If no plantar response can be elicited with the patient's knee flexed and thigh externally rotated, it can be elicited by extending the patient's knee, or even applying pressure on the knee (thigh being in the neutral position).

With repeated stimulation of the sole of the foot, the plantar response may become fatigued, and the extensor plantar response may not be elicitable.

Equivocal Babinski Sign

Plantar response is said to be equivocal in following situations:

1. There is a rapid but brief extension of toes at first, which is followed by flexion or predominant flexion followed by extension.
2. There is only extension of great toe or extension of great toe with flexion of small toes.
3. There is no response to plantar stimulation, particularly if there is paralysis of dorsiflexors.
4. There may be flexion of knee and hip with no movement of toes.

Minimal Plantar Response

On eliciting the plantar reflex, no movement of the toes may be seen. The presence of a positive plantar response can then be assessed by feeling for the contraction of tensor fascia lata and adductors of the thigh.

Pseudo-Babinski Sign

False Babinski sign may sometimes occur in the absence of pyramidal tract lesion. This may be seen in the following conditions.

- a. A voluntary withdrawal in overtly sensitive individuals on attempting to stroke the sole of the foot.
- b. As a response in plantar hyperesthesia
- c. Application of a strong or painful stimulus to the sole of the foot.
- d. In athetosis or chorea, where the big toe may extend as a response to dystonic posturing.
- e. If the short flexors of the toes are paralysed (due to lower motor neuron lesion), there may be an inversion of the plantar reflex.

Differentiation between Babinski and Pseudo-Babinski Sign

<i>Babinski Sign</i>	<i>Pseudo-Babinski Sign</i>
1. Contraction of hamstring muscles can be felt	There is no associated contraction of the hamstring muscles
2. Pressure on the base of the great toe while eliciting the plantar reflex does not inhibit the extensor response	Pressure on the base of the great toe while eliciting the plantar response will inhibit the withdrawal extensor response

Babinski Sign in Absence of Pyramidal Tract Lesion

1. Infancy (up to 1 year of age)
2. Deep sleep
3. Deep anaesthesia
4. Narcotic overdose
5. Alcohol intoxication
6. Following electroconvulsive therapy
7. Coma secondary to metabolic disturbances
8. Post-traumatic states
9. Post-ictal state
10. In Cheyne-Stokes respiration, the extensor response may appear during the period of apnoea, whereas in the phase of active respiration the normal reflex is seen.

Other Methods of Obtaining the Plantar Reflexes

1. *Oppenheim reflex*: A firm stroke with the finger and thumb is applied down either side of the anterior



Fig. 8.54: The plantar reflex

border of the tibia, greater pressure being applied to the medial side.

2. *Gordon reflex*: The calf muscles are squeezed.
3. *Chaddock reflex*: A light stroke is applied below the lateral malleolus.

These reflexes show a positive Babinski response when the reflexogenic area spreads up in the lower limb. They may be useful in eliciting the Babinski response when the patients are uncooperative or in patients whose soles are extremely sensitive (Fig. 8.54).

Deep Tendon Reflexes (Fig. 8.58)

These reflexes can conveniently be tested while the patient lies down in a partially propped up position.

Proper positioning of the limbs for elicitation of the deep tendon reflexes is important.

The deep tendon reflexes are best elicited using a long and flexible knee hammer and the examiner allowing the weight of the hammer to decide the strength of the blow applied.

These reflexes are assessed by striking the muscle tendon and not the muscle belly.

Prerequisites:

- Look straight to avoid tonic neck reflex.
- Midway position in the range of movement of the muscle being tested.

Reinforcement maneuvers aid in eliciting deep tendon reflexes by

- Supraspinal
- Fusimotor
- Long-loop mechanism

The response of a deep tendon jerk can be graded as follows:

Grade 0	Absent reflexes
Grade 1	Present (as normal ankle jerk)
Grade 2	Brisk (as normal knee jerk)
Grade 3	Exaggerated
Grade 4	Clonus.

Deep tendon reflexes may sometimes have to be elicited by applying certain manoeuvres, when they cannot be elicited normally. The manoeuvres that can be applied to elicit deep tendon reflexes in the upper limb are either clenching the teeth or making a fist with the hand of the limb not being tested. In the elicitation of deep tendon reflexes in the lower limbs, the *Jendrassik's manoeuvre* may be applied in which the patient interlocks the fingers of both hands together and tries to pull them against each other's resistance.

Other Allied Reflexes

The Hoffman reflex: The terminal phalanx of the patient's middle finger is flicked downwards between the examiner's finger and thumb. In states of hypertonia, the tips of the other fingers flex and the thumb flexes and adducts (Fig. 8.55).



Fig. 8.55: Hoffman reflex



Fig. 8.56: Wartenberg's reflex

Wartenberg's sign: The patient supinates his hand, slightly flexing the fingers, with the thumb in abduction. The examiner pronates his hand and links his flexed fingers with that of the patient's fingers. Both then flex their fingers and pull against each other's resistance. Normally, the thumb extends, though the terminal phalanx may flex slightly. In the presence of hypertonia, the thumb adducts and flexes strongly (Fig. 8.56).

This sign indicates pyramidal tract lesion and may be taken as an equivalent of Babinski sign in case of amputation of both lower limbs.

Abnormalities of Tendon Reflexes

Diminished or Absent Tendon Reflexes

These are seen in lower motor neuron lesions involving any part of the reflex arc

- Lesion of the sensory nerve (polyneuritis)
- Lesion of the sensory root (tabes dorsalis)
- Lesion of the anterior horn cell (poliomyelitis)
- Lesion of the anterior root (compression)
- Lesion of the peripheral motor nerve (trauma, polyneuritis).

Exaggerated Tendon Reflexes

Reflexes may be brisk if the patient is agitated, frightened, or anxious. Exaggerated tendon reflexes suggest the presence of pyramidal tract lesion.

Pendular Reflex

The limb continues to oscillate to and fro after elicitation of the reflex, covering equal distance on both sides of the neutral position, at least for 3 oscillations. This is best demonstrated on eliciting the knee jerk with the patient sitting and his legs dangling down loosely. This pendular reflex is seen in lesions of the cerebellum.



Reflex	Technique	Segmental Innervation and Peripheral Nerve	Normal Response
Jaw jerk	The patient is asked to keep his mouth partly open with his mandible hanging loosely. A finger is placed over the chin and a downward stroke is delivered with the knee hammer	Pons (trigeminal nerve)	Slight elevation of the mandible
Trapezius jerk	The finger is placed over the trapezius muscle on the shoulder and the finger is stroked with the knee hammer	Spinal accessory nerve and C _{1,2}	Slight elevation of the shoulder
Pectoral reflex	Place the tips of the fingers on the pectoral muscle as it forms the anterior fold of the axilla and strike the fingers	C _{5,6,7,8} , and T ₁ (Medial and lateral pectoral nerves)	Visible contraction of the pectoral muscle with adduction of the arm
Biceps jerk	The upper limb is partially flexed at the elbow. Press the forefinger gently on the biceps tendon in the antecubital fossa and then strike the finger with the knee hammer (Fig. 8.57)	C ₅ (musculo-cutaneous nerve)	Flexion of the elbow and visible contraction of the biceps muscle
Supinator jerk	The upper limb is partially flexed at the elbow in a midprone position. Strike the lower end of the radius about 5 cm above the wrist (Fig. 8.58)	C _{5,6} (radial nerve)	Contraction of the brachioradialis and flexion of the elbow and slight flexion of fingers
Triceps jerk	The upper limb is flexed at the elbow. Keep the patient's hand across the trunk and strike the triceps tendon 5 cm above the elbow (Fig. 8.58)	C _{6,7} (radial nerve)	Extension of the elbow and contraction of the triceps
Finger flexion	Allow the patient's hand to rest with palm upwards, the fingers slightly flexed. The examiner gently interlocks his fingers with the patient's and strikes them with knee hammer (Fig. 8.58)	C _{6,7,8} and T ₁	Slight flexion of all fingers
Knee jerk	The knees are partially flexed and rested on the examiner's forearm. The quadriceps tendon is then struck with knee hammer (Fig. 8.59)	L _{2,3,4} (femoral nerve)	Extension of the knee and visible contraction of the quadriceps
Ankle jerk	The patient's leg is externally rotated and flexed at the knee. The patient's forefoot is gently dorsiflexed and the achilles tendon is then struck with the knee hammer (Fig. 8.59)	S ₁ (medial popliteal nerve)	Plantar flexion of the foot and visible contraction of the gastrocnemius

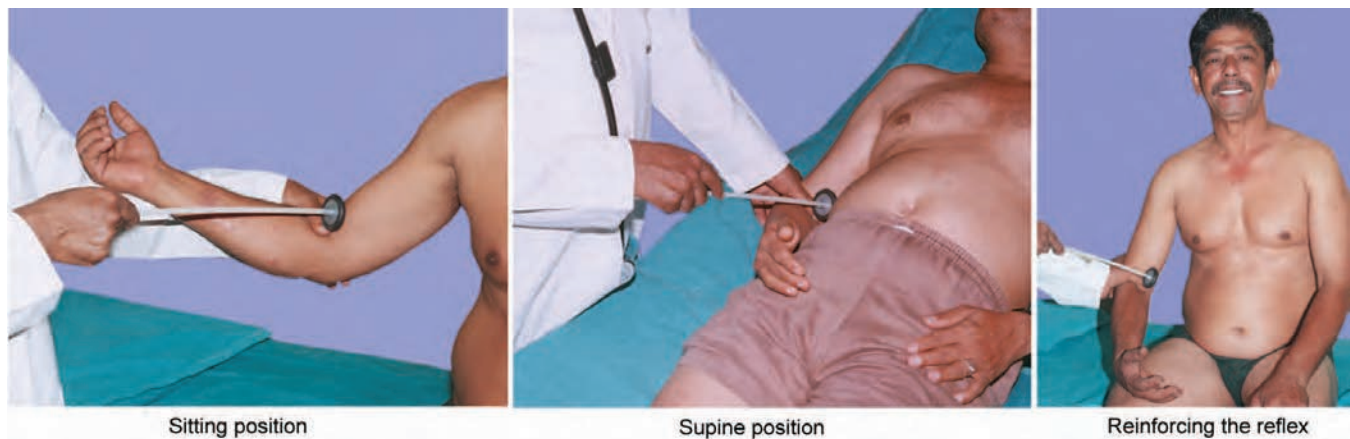

Fig. 8.57: Methods of eliciting biceps reflex

Rossolimo's Reflex

Sudden stroke over the ball of the foot leads to contraction of all toes.

Pseudo-myotonic Reflex

There is a delayed muscle relaxation after brisk contraction of the muscle on elicitation of the deep tendon reflex.



Triceps reflex—lying down position



Triceps reflex—sitting position



Supinator reflex—sitting position



Supinator reflex—supine position



Finger flexion reflex—method 1



Finger flexion reflex—method 2

Fig. 8.58: Deep tendon reflexes



Knee jerk—classical method



Method of eliciting pendular knee jerk



Ankle jerk—classical method



Ankle jerk—kneeling position



Ankle jerk—prone position
slow relaxation is best observed



Knee jerk—jendrassik's manoeuvre

Fig. 8.59: Deep tendon reflexes

This is best seen on eliciting the ankle jerk. It is seen in myxoedema. It is also seen with administration of β blockers and in hypothermia.

Inverted Reflexes

Inverted Radial Reflex

On eliciting the supinator jerk, there is absence of flexion at the elbow, and instead there is brisk finger flexion and thumb adduction. The biceps jerk is absent and the triceps jerk is exaggerated. Presence of this reflex indicates that the lesion is at the level of C_{5,6} segment.

Inverted Biceps Reflex

On eliciting the biceps jerk, there is no flexion at the elbow, but instead there is extension at the elbow due to contraction of the triceps muscle and there is brisk finger flexion along with thumb adduction. Presence of this reflex indicates that the lesion is at the level of C_{5,6} segment.

Inverted Triceps Reflex

Paradoxical elbow flexion occurs on attempted elicitation of triceps jerk. The lesion is at the level of C₆ and C₇.

Inverted Knee Reflex

On eliciting the knee jerk, there is no extension of the knee, but instead there is flexion of the knee due to contraction of the hamstring muscles. Presence of this reflex indicates that the lesion is at the level of L_{2,3,4} segment.

Primitive Reflexes (Released Reflexes)

Primitive reflexes are some of the reflexes present at birth or in early infancy. These reflexes disappear as cortical control develops.

Later in life, these reflexes may reappear due to diffuse cortical damage, as the subcortical structures are released from the inhibitory influence of the higher cortical centre.

Grasp Reflex

Patient's palm is touched on the radial border between the thumb and index finger with an object. The patient's fingers involuntarily flex slowly and grasp the object. This reflex is seen in contralateral frontal lobe lesion.

Groping Reflex

The examiner shows an object to the patient or may touch the object on the patient's hand, and then takes

the object away from the patient. The patient on seeing or feeling the object tries to grope for it. This reflex is a sign of contralateral frontal lobe lesion.

Avoiding Reflex

Examiner touches the skin on the ulnar side of the patient's hand. The patient's hand reflexly moves away from the stimulus. This is present in lesion in the contralateral parietal lobe or its connections.

Grasping, groping and avoiding reflexes have a localising value when present unilaterally.

Palmomentary Reflex

The examiner strokes the skin on the thenar eminence of the hand with a blunt object such as the handle of the knee hammer. Puckering of the skin over the chin on the same side, produced by the contraction of the ipsilateral mentalis muscle is seen.

Sucking Reflex

The corner of the mouth is touched with the index finger. Involuntary opening of the mouth occurs, as though the patient is trying to suck something.

Snout Reflex

Keep a finger on the upper lip and tap lightly over it. Puckering and protrusion of the lips is seen.

Glabellar Reflex

The examiner taps the glabella (root of the nose) repeatedly with the index finger, from above and behind the patient's head (Fig. 8.60).



Fig. 8.60: Glabellar tap



Normal individuals respond by blinking to the first 2–3 taps and then there is no response.

Glabellar reflex is said to be present when the response (blinking) continues as long as the tapping is continued (seen in Parkinsonism and diffuse degenerative diseases of the brain).

Cerebellum

Cerebellum is the largest part of the hindbrain situated in the posterior cranial fossa behind the pons and medulla. It is an infratentorial structure that coordinates voluntary movements of the body (Fig. 8.61).

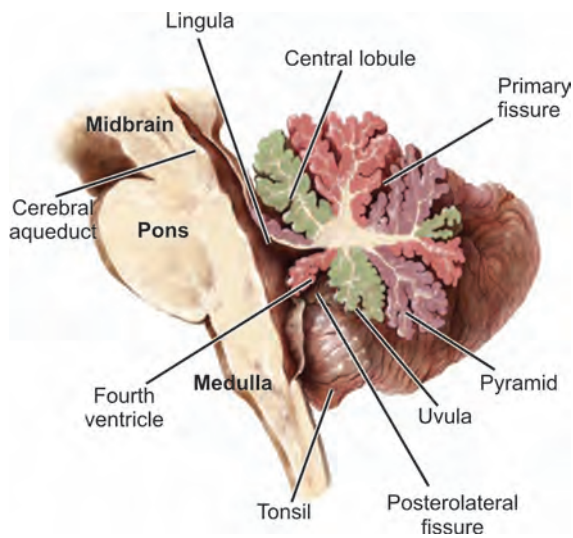

Fig. 8.61: Anatomy of cerebellum

Nuclei of the Cerebellum

There are four pairs of nuclei

1. Nucleus dentatus
2. Nucleus globosus
3. Nucleus emboliformis
4. Nucleus fastigii.

Morphological and Functional Divisions of the Cerebellum (Figs 8.62 to 8.64)

1. *Archicerebellum* (phylogenetically oldest part of cerebellum)—*Vestibular*: It is made up of the flocculonodular lobe and lingula. It is chiefly vestibular in connections, and controls the axial musculature and bilateral movements used for locomotion and maintenance of equilibrium.
2. *Paleocerebellum*—*Spinocerebellar*: It is made up of the anterior lobe of the cerebellum and the pyramid and

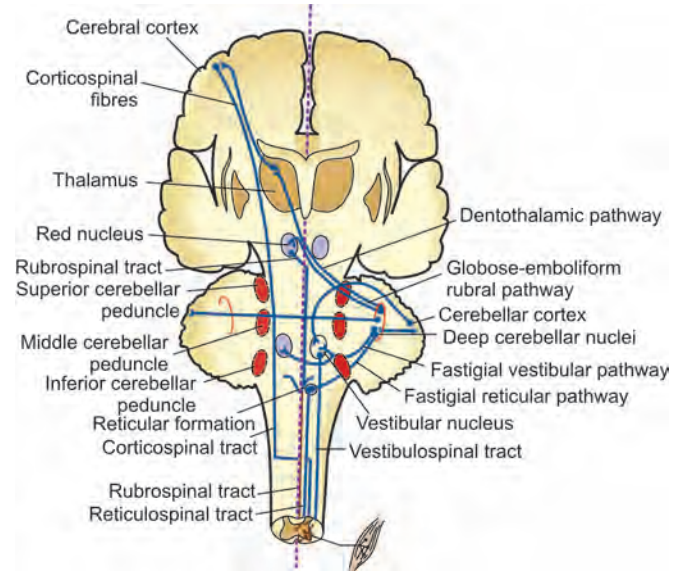

Fig. 8.62: Cerebellar efferent fibres

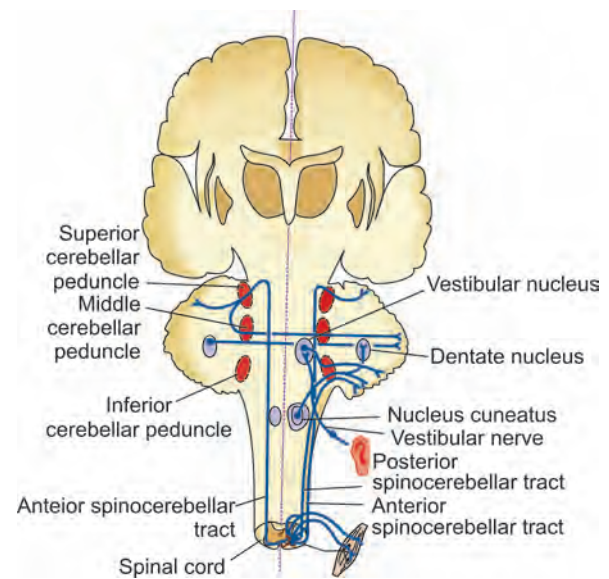

Fig. 8.63: Cerebellar afferent fibres from spinal cord and ear

uvula of the inferior vermis. It is chiefly spinocerebellar in connections. It controls tone, posture and crude movements of the limbs.

3. *Neocerebellum* (phylogenetically newest part of cerebellum)—*Corticocerebellar*: It is made up of the middle lobe. It has chiefly cortico-cerebellar connections. It is primarily concerned with the regulation of pyramidal (fine) movements of the body.

Visceral Reflexes

Reflex	Technique	Segment	Normal Response
Anal reflex	Stroke the perianal region gently	Afferent: Pudendal nerve Segment: S _{2, 3, 4}	Brisk contraction of the external anal sphincter is noted
Bulbo-cavernous reflex	The glans penis is gently pinched and contraction of the bulbocavernous muscle is looked for by placing a finger at the root of the scrotum	Afferent: Pudendal nerve Segment: S _{2, 3, 4} Efferent: Pudendal nerve	Contraction of the bulbocavernous muscle

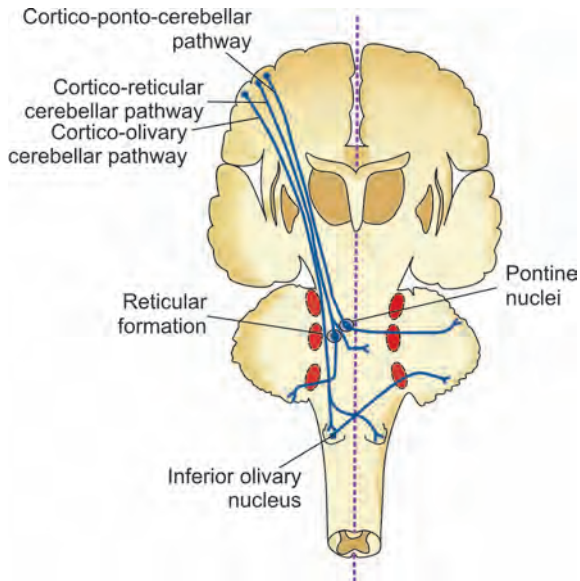

Fig. 8.64: Cerebellar afferent fibres from cerebral cortex



Fig. 8.65: Tandem walking

Clinical Manifestations of Cerebellar Dysfunction

1. *Dyssynergia*: This is a difficulty in carrying out complex movements. There is a decomposition of movement (the act is broken down into its component parts).
2. *Dysmetria*: It is the loss of ability to gauge the distance, speed, or power of movement. The act may be stopped before the goal is reached, or the individual may overshoot the desired point.
3. *Dysdiadochokinesia*: It is the loss of ability to perform alternating movements smoothly and rapidly (e.g. difficulty in performing rapid and alternating supination and pronation of the hands).
4. *Rebound phenomenon*: The patient is asked to flex his elbow against the examiner's resistance. The examiner then suddenly lets go of the patient's forearm. In cerebellar lesion there is a loss of the 'check reflex' due to a failure of the ability to relax

the contraction of the flexors of the forearm and rapidly contract the antagonists, or extensors. This may result in the patient striking his face with his hand. It is therefore necessary for the examiner to protect the patient's face with his other hand.

5. *Hypotonia*: There is a decrease in resistance to the passive movements of the joints.
6. *Abnormalities of the gait*: The gait is ataxic, with a tendency to fall in the direction of the affected side. Tandem walking is not possible (Fig. 8.65).

On walking around a chair, the patient sways on the side of the cerebellar lesion.

7. *Speech disturbances*: The speech may be scanning (incoordination of the tongue) or staccato (incoordination of the larynx). It is a dysarthria produced due to incoordination of the muscles of articulation.
8. *Nystagmus*: There is a jerky nystagmus with the fast component of the nystagmus towards the affected side.



9. *Pendular knee jerk*: At least three oscillations of equal excursion of the lower limb from the neutral position is noted on elicitation of the knee jerk.
 10. *Intention tremor*: It has a frequency of 2-4 Hz and is predominantly seen over limbs, trunk and head. It is enhanced by emotional stress and attenuated by alcohol.
 11. *Titubation*: This is a rhythmic oscillation of head on the trunk or the trunk itself. It invariably indicates disease of cerebellum or its connections.
4. Vertebrobasilar artery
 - d. Demyelinating (disseminated sclerosis)
 - e. Drugs
 1. Phenytoin sodium
 2. Barbiturates
 3. Alcohol
 4. Piperazine citrate
 5. Streptomycin, gentamicin, kanamycin
 - f. Endocrine
 1. Hypothyroid state
 - g. Hyperpyrexia.

Localisation of Cerebellar Lesions

1. *Lesion of the vermis*: This produces titubation, truncal and gait ataxia.
2. *Lesion of the flocculonodular lobe*: This produces predominantly vestibular symptoms.
3. *Lesion of the neocerebellum*: This produces all signs of cerebellar lesion.
4. *Lesions of the cerebellar hemisphere*: These produce ataxia of the limb and all the other cerebellar signs on the side of the hemispherical involvement (due to double crossing of the cerebellar fibres).



Causes of Cerebellar Lesions

Acute Onset

- a. Trauma (gives rise to small capillary bleeding)
- b. Infections
 1. Encephalitis
 2. Cerebellar abscess
- c. Vascular (thrombosis or haemorrhage)
 1. Posterior inferior cerebellar artery
 2. Anterior inferior cerebellar artery
 3. Superior cerebellar artery

Gradual Onset

- a. Congenital craniovertebral anomaly
- b. Degenerative, familial and hereditary ataxias: refer Chapter on Ataxic Disorders
- c. Neoplastic
 1. Cerebellopontine angle tumours
 2. Cerebellar tumours
 3. Pontine tumours.

Treatable Cerebellar Lesions

1. Tumour
2. Abscess
3. Infection
4. Haemorrhage
5. Alcohol
6. Hypothyroidism
7. Drugs (anticonvulsants)
8. Vitamin E, B₁ and B₁₂ deficiencies
9. Wilson's disease
10. Neurocysticercosis
11. Lyme disease
12. Episodic ataxias.

Peduncle	Afferent tracts	Efferent tracts
A. Superior cerebellar peduncle (midbrain)	<ol style="list-style-type: none"> 1. Anterior spinocerebellar 2. Tectocerebellar 	<ol style="list-style-type: none"> 1. Cerebellorubral, crossed ascending fibres from globose and emboliform nuclei 2. Dentatothalamic, crossed ascending fibres 3. Dentatoolivary, crossed descending fibres 4. Fastigioreticular, uncrossed and descending fibres
B. Middle cerebellar peduncle (pons)	<ol style="list-style-type: none"> 1. Pontocerebellar: is the cortico-pontocerebellar pathway 	
C. Inferior cerebellar peduncle (medulla)	<ol style="list-style-type: none"> 1. Posterior spinocerebellar 2. Cuneocerebellar, the posterior external arcuate fibres 3. Olivocerebellar 4. Parolivocerebellar 5. Reticulocerebellar 6. Vestibulocerebellar 	<ol style="list-style-type: none"> 1. Cerebellovestibular 2. Cerebello-olivary 3. Cerebelloreticular

The Sensory System

Perception of normal sensation demands moment to moment nervous system activity.

Abnormalities of sensory phenomena are described under two categories.

1. Positive Phenomena

These include tingling, pins and needles, pricking, band like sensations, electric shock like or lightning like sensations. These are produced as a result of ectopic generation of volleys of impulses at some site of lowered neural threshold either in central or in peripheral nervous system. Positive phenomena represent heightened activity in sensory pathways and are not necessarily associated with any demonstrable sensory deficit.

2. Negative Phenomena

These result from loss of sensory function and are characterised by numbness or diminution or absence of sensation in a particular distribution. These are accompanied by definite sensory loss on examination. At least 50% of the fibres innervating a particular site should be lost before sensory deficit could be demonstrated.

If the rate of loss is slow, patient may not appreciate the sensory loss and it is very difficult to demonstrate them clinically.

In case of posterior column sensory loss, the patient cannot walk or stand unaided and sometimes show continuous worm like involuntary movements called 'pseudoathetosis' in the arms and hands especially when the eyes are closed.

Similarly, patients have imbalance, with clumsiness of precision movements and unsteadiness of gait which is termed as sensory ataxia. This again gets worsened with the eyes closed or in the dark.

Cutaneous Afferent Innervation

It is subserved by

1. Nociceptors (naked nerve endings) and
2. Mechanoreceptors (encapsulated terminals)
 - a. Pacinian corpuscles (vibration or tickle sense)
 - b. Meissner's corpuscles and hair follicle receptors (tapping)
 - c. Krause's end bulb
 - d. Merkel's cells (pressure) and Ruffini's endings (touch and pressure).

Small Fibres Subserve

- Pain (cutaneous nociceptors)
- Temperature (cutaneous thermoreceptors for hot and cold).

Large Fibres Subserve

- Vibration (mechanoreceptors—Pacinian corpuscles)
- Joint position (joint capsule, tendon endings and muscle spindles)
- Touch is appreciated by cutaneous mechanoreceptors and naked nerve endings (large and small fibres).

Sensory Pathways

From the peripheral nerves sensations reach dorsal roots and dorsal horn of spinal cord.

Spinothalamic System

Small fibres subserving pain and temperature (small myelinated and unmyelinated fibres) ascend for 2–3 segments and cross and ascend in lateral spinothalamic tract through spinal cord, brainstem to ventroposterolateral nucleus (VPL) of thalamus and from there to post-central gyrus of parietal cortex (area 3, 1, 2) (Fig. 8.66).

Lemniscal System

Large fibres subserving tactile, position sense and kinesthesia project rostrally in the ipsilateral posterior column and make their 1st synapse in the gracile and cuneate nuclei of lower medulla. The 2nd order neuron decussates and ascends in medial lemniscus located medially in medulla and in the tegmentum of pons and midbrain and synapses in VPL. The 3rd order neurons project to parietal cortex (Fig. 8.67).

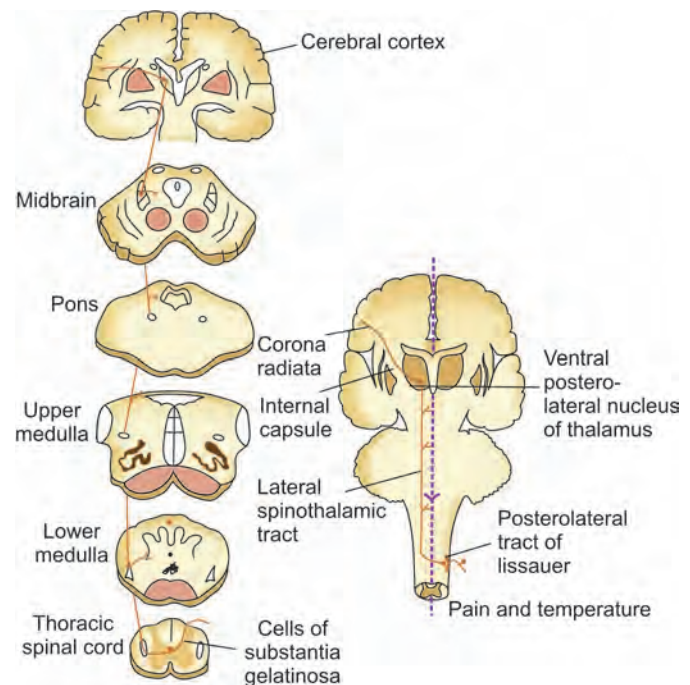

Fig. 8.66: Pain and temperature pathways

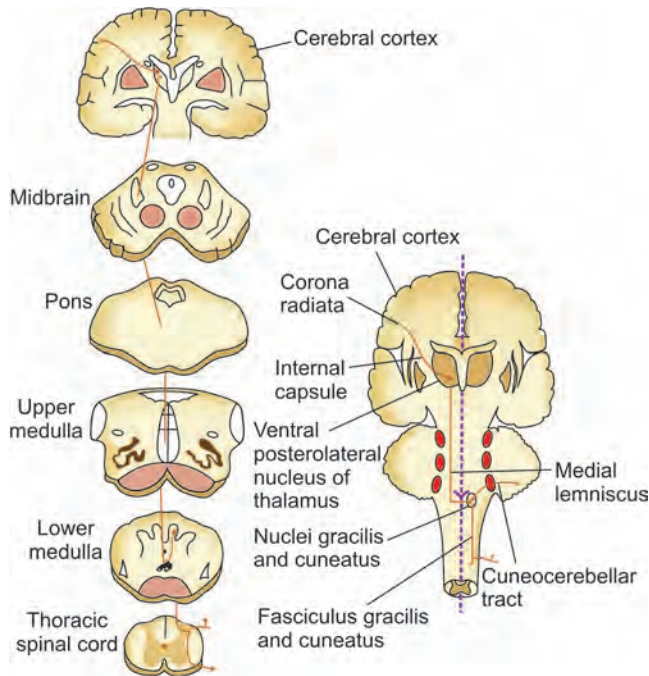

Fig. 8.67: Posterior column

Definitions

Paraesthesia: Abnormal sensation perceived without an apparent stimulus.

Dysesthesia: Perverted interpretation of sensation such as burning or tingling feeling in response to tactile or painful stimulation.

Hypesthesia or hypoesthesia: Reduction of cutaneous sensation to a specific type of testing such as pressure, light touch, warm or cold stimuli.

Anaesthesia: Complete absence of skin sensation to the above stimuli and to pin prick.

Hyperesthesia: Exaggerated perception of sensations in response to mild stimuli (light touch/stroking of skin).

Allesthesia or synesthesia: When sensation of touch is experienced at a site remote from point of stimulation.

Allochiria: Referring of a sensation to the opposite side of the body.

Hypalgesia: Diminished perception of pain (nociception).

Hyperalgesia: Exaggerated perception of pain

Allodynia: Ordinarily nonpainful stimulus is experienced as painful and excruciating.

Hyperpathia: Excessive reaction to pain, usually with a raised threshold to stimulation. It includes hyperesthesia, hyperalgesia, allodynia.

Phantom or spectral sensations: Spontaneous sensations referred to insensitive areas (in lesions of cord/cauda equina).

Phantom limb: It is the sensation of continued presence of an absent portion of body or of pain, paraesthesia or movement in the absent limb.

Causalgia: It is a neuritis characterised by disagreeable, burning type of pain often accompanied by trophic changes and is seen in lesions of median and sciatic nerves.

Meralgia paraesthetica: Painful paresthesia in the area of distribution of lateral femoral cutaneous nerve, seen in diabetes mellitus.

Digitalgia paraesthetica: An isolated neuritis of dorsal digital nerve of one of the fingers.

Acro-paraesthesia: A disease characterised by tingling, numbness, burning and painful extremities, chiefly of tips of fingers and toes often accompanied by cyanosis.

Modalities of Sensation to be Tested

Exteroceptive sensations: Pain, light touch and temperature (derived from sources outside the body).

Proprioceptive sensations: Sense of position, passive movement, vibration and deep pain (impulses from body itself).

Cortical sensations: Tactile localisation, two point discrimination, stereognosis, graphesthesia.

Visceral or interoceptive sensations: These sensations are rarely examined as a clinical bedside routine.

Arrangement of Sensory Fibres

Posterior column: Fibres from lower part of the body are displaced medially as more fibres enter since they do not cross at the spinal segmental level.

Spinothalamic tract: Fibres from lower part of the body are displaced more laterally to those from upper part since they cross at the spinal segmental level.

Thalamus: Fibres from lower part of body lie laterally to those from trunk and arms and fibres from face lie most medially of all.

Sensory cortex: Fibres from lower limb terminate near the superior longitudinal fissure and from the face, in lower part of post-rolandic gyrus (post-central gyrus). Hand and mouth occupy larger areas than other parts of body.

Sensory Dermatomes

Clues (Fig. 8.68)

1. Patient is considered to be standing with the palm of the hands facing forwards
2. C₁—no cutaneous supply; supplies meninges
C₂—occiput, earlobe, angle of jaw
3. C₄—above clavicle
4. C₅—deltoid; outer aspect of shoulder tip
5. C₆—radial half of forearm including thenar eminence and thumb
6. C₇—(longest spinous process—longest finger) middle finger
7. C₈—little finger, hypothenar eminence, and ulnar aspect of hand
8. T₁—ulnar aspect of forearm
9. T₂—ulnar aspect of arm
10. T₃—lies in axilla

11. T₄—nipple
12. T₈, T₁₀, T₁₂—supply rib margin, umbilicus and pubis respectively
13. L₁—inguinal ligament.
14. L₃—lies at knee
15. L₄—medial aspect of leg
16. L₅—lateral aspect of leg (runs diagonally from outer aspect of tibia to the inner aspect of foot)
17. S₁—includes little toe, tendo-Achilles, strip of skin above it and sole
18. S₂—calf muscle and hamstring
19. S_{3,4,5}—perianal region.

Rule of 3

- C₃—nape of neck
T₃—axilla
L₃—knee
S₃—perianal.

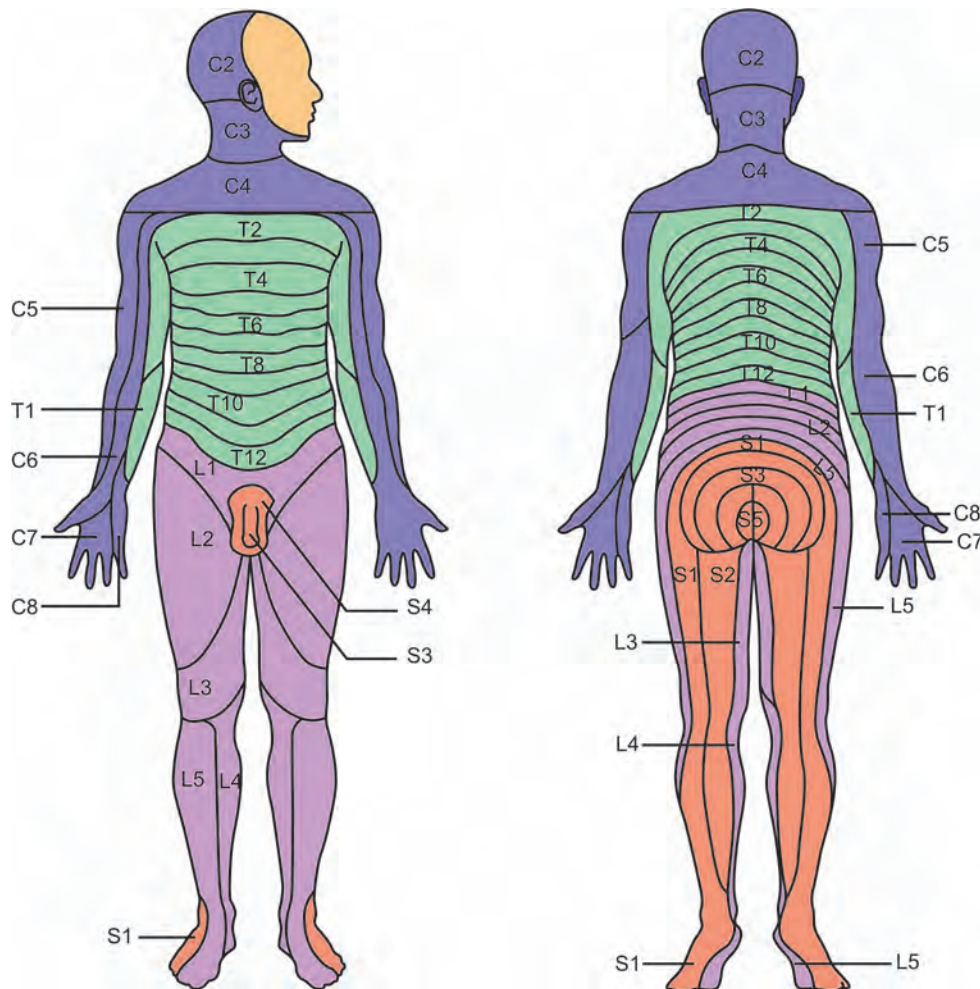

Fig. 8.68: Dermatome pattern



Method of Examination

Preliminary Screening

After instructing the patient, choose a part of patient's body which is expected to be normal (from history) and touch him precisely.

Ask him

- if he can feel anything
- what is that he can feel
- if it is sharp or blunt

Later do detailed analysis always moving from impaired to normal sensation.

Touch

A small piece of cotton wool is used. After similar preliminary screening, tell the patient to shut his eyes and to say 'yes' if he feels anything.

Cotton wool is shaped to a point and the skin is touched lightly, testing again in dermatome areas and mapping out abnormalities. Fine camel's hair brush can also be used to test. Do not stroke hairy areas.

Pain

Tested using a sharp pin with a rounded head. Same preliminary screening is adopted.

Note: Pulp is insensitive to pain but very sensitive to light touch.

Deep Pain

Tested by firm squeezing over muscles (usually calf muscle) and tendons. Patient is asked to indicate when the pressure becomes painful and the examiner gauges whether the force applied is painful in normal people.

Temperature

Preliminary Screening

Patient can compare the temperature of a cold object such as a tuning fork in the main sensory areas of the body.

After this, use test tubes containing hot water (44°C) and cold water (30°C).

Sensory Levels

Spinal segments do not correspond to vertebral levels owing to the disparity in their lengths, i.e. spinal cord is shorter than vertebral canal and ends at L₁. To find out the segmental level do the following.

- For lower cervical vertebrae, add 1
- For thoracic 1–6, add 2
- For thoracic 7–9, add 3
- 10th thoracic arch overlies lumbar 1 and 2 segments

- 11th thoracic arch overlies lumbar 3 and 4 segments
- 12th thoracic arch overlies lumbar 5
- First lumbar arch overlies the sacral and coccygeal segments
- In the lower dorsal region the tip of a spinous process marks the level of the body of vertebra below.

In cord lesions, there may be a clear cut upper level of sensory abnormality defined by a zone of hyperaesthesia.

Remember to test for sacral sparing.

While testing for a sensory level by moving the pin from lower to higher spinal segments, there is a danger of error, i.e. a sudden increase in intensity of stimulus, e.g. between C₄ and T₄ due to *summation of sensory stimuli*. To overcome the error, careful examination of upper limb including axilla should be carried out.

Examination over the Trunk

Earliest sensory deficit in the trunk may be detected anteriorly closer to midline supplied by distal terminal segments of the nerves. However, because of overlapping, exact level or site of sensory loss can be made out clearly only by examining paraspinous region.

Proprioceptive Sensations

Position Sense

1. Patient's eye should remain closed while testing.
2. Place the patient's arm in a particular position, then move it away and ask him to replace it himself and then to place the opposite limb in a similar position.
3. Ask him to touch the forefinger of one hand with the forefinger of the other and make it harder by changing different positions.
4. Let him adopt similar positions with legs and ask him to raise one leg so as to touch his own outstretched hand with his big toe.
5. Ask him to place his forefinger accurately on tip of nose and his heel accurately on his knee.

Sense of Passive Movement (Joint Sense)

1. Eyes remain closed
2. After fixing the joint, the digit or toe at the terminal interphalangeal joint is moved up or down (15°–30°) by holding the sides of digits between the finger and the thumb not touching the adjacent toe or finger. Pulp of the finger not to be touched (Fig. 8.69).

The patient is asked to say in which direction the movement occurred after clearly explaining which movement is up or down.



Fig. 8.69: Testing joint position sense

3. Repeat it several times avoiding alternate movements and if any error is made the test should be continued until at least 6 successive correct responses are given.
4. If digit movement could not be detected in the first place, same test is carried out at the wrist, elbow and knee.
5. It is common in posterior column deficit to have numbness in the affected limb which cannot be demonstrated objectively.

Romberg's Test for Position Sense

Patient stands upright with the feet together and eyes closed (Fig. 8.70). Where there is a proprioceptive or



Fig. 8.70: Romberg's test



Fig. 8.71: Testing vibration sense—medial malleolus

vestibular deficit, balance is impaired only when the eyes are closed, and the patient may fall if not caught.

Minimal lesions can be demonstrated by asking the patient to stand on his toes with the eyes closed.

Vibration Sense

This is also first impaired at the periphery of limbs. Ideally tested with the vibrating tuning fork with a frequency of 128 cycles per second with the eyes closed. 128 Hz tuning fork decays later (15–20 seconds) compared to 512 Hz and hence is preferred. Only the stem of the tuning fork should be touched and not the prongs (Fig. 8.71).

Tuning fork is struck and placed on bony points starting peripherally at the terminal phalanx, then successively over medial or lateral malleoli, tibial tuberosity, anterior superior iliac spine, ribs or costal margin, lower end of radius, elbow and clavicle (Figs 8.72 and 8.73).



Fig. 8.72: Testing vibration sense over great toe



Fig. 8.73: Testing vibration sense over spine

Placing it in turn on spinous processes of vertebrae may give the only clear sensory level of a posteriorly situated spinal tumour.

Keep the tuning fork as long as the vibration persists.

Always compare with the other side. In minor degrees of impairment the deficit may not be appreciable.

Control sites: Place the tuning fork over patient's sternum and forehead. Also compare the sensation with the sensation of the examiner himself at the same points.

Timed Vibration Sense

Assessment is by counting the seconds that the examiner feels the vibration sense longer than the patient.

Vibration sense is impaired in old age above 70 years especially at ankle.

Vibration sense disappears earlier than joint sense.

Muscle Sensitivity

Muscles of forearm, calf and tendo-Achilles are squeezed. Normally patient has discomfort.

There may be

Increased muscle tenderness	Infective polyneuritis Subacute combined degeneration of spinal cord Myositis
-----------------------------	---

Decreased muscle tenderness	Tabes dorsalis Syringomyelia Carcinomatous neuropathy Lesions of posterior roots and root entry zone of the spinal cord.
-----------------------------	---

Barber's Chair Sign or Lhermitte's Sign

If there is a lesion of posterior column of cervical region, sudden flexion or extension of neck may give an electric shock like sensation which travels rapidly down the trunk or even to hand and feet. Lhermitte's sign is positive in the following conditions:

- Multiple sclerosis
- Cervical spondylosis
- Syringomyelia
- Subacute combined degeneration of spinal cord
- Tumour of cervical cord.

Cortical Sensations

Function of Sensory Cortex

Accurate localisation of stimuli and assessment of shape, weight, size and texture of objects.

Cortex receives information from afferent pathways and interprets them in the light of previous experience.

Cortical sensations should be tested only if primary modalities of sensations are intact.

All the sensations should be compared with that of the opposite side.

I. Point Localisation (Tactile Localisation)

This tests the ability of the patient to localise accurately the point touched with the head of a pin or fingertip when the eyes are closed and he is asked to indicate the point touched with his own fingers. Painful stimuli should not be used.

It is more precise at periphery than proximally.

Tactile Extinction/Perception Rivalry/Sensory Inattention

Bilateral simultaneous stimulation at analogous sites can be carried out to determine whether the perception of touch is extinguished consistently on one side or the other—*extinction on bilateral simultaneous stimulation*. However, perception of sensation is normal when tested separately on either side. It is a sign of contralateral parietal lobe lesion.

II. Two-point Discrimination

This tests the ability to distinguish the contact of two separate points applied simultaneously to the skin. Finger pulp and lips 3–5 mm separation well recognised

Palm	2–3 cm
Sole	4 cm
Dorsum of foot	5 cm and above



Legs	5 cm and above
Back	5 cm and above

If two-point discrimination is lost in the presence of intact posterior column sensations, it indicates a parietal lobe lesion.

III. Stereognosis

It is the ability to recognize an object purely from the feel of its shape and size.

It requires intact peripheral sensation and evocation in the cortex of the constellation of ideas and memories necessary for recognition.

Test objects must be familiar, easily identifiable and large enough for a weak hand to feel.

Patient with the eyes closed, is asked to identify the object placed in his hand. If he fails (*astereognosis*) or takes a long time to decide, it is placed on the other hand for comparison.

Identification of Textures

A piece of paper, cloth, wood or metal is placed in the hand of the patient who is then asked to identify the nature of the substance.

IV. Graphaesthesia

Ability to recognize letters or numbers or diagrams written on the skin with a blunt point.

Patient closes his eyes and letters or numbers are traced out on the palm, anterior forearm, thigh or lower leg. Clear figures like 8, 4, and 5 should be used. More difficult 6, 9, and 3 are used as finer tests.

If peripheral sensation is normal, loss of graphaesthesia indicates parietal lobe lesion (*agraphaesthesia*).

Cortical sensory loss is well appreciated in sub-cortical lesions because of crowded fibres especially in posterior limb of internal capsule than true cortical lesions where patient's interpretation of cortical sensations are variable, as the fibres are widely scattered.

Sensory Dissociation

Pinprick and thermal sensations are lost but touch is spared—a sign of spinothalamic tract involvement especially if the lesion is unilateral. Sensory dissociation occurs in the following conditions:

1. Intramedullary lesions (hydromyelia or syringomyelia)
2. Small fibre neuropathy (Pseudosyringomyelia)
 - a. Leprous neuritis
 - b. Hereditary sensory neuropathy
 - c. Amyloid neuropathy

- d. Diabetic polyneuropathy
3. Anterior spinal artery thrombosis (posterior column spared)
 4. PICA syndrome
 5. Brown–Sequard syndrome.

Various Sensory Lesions (Fig. 8.74)

Total Contralateral Loss of All Forms of Sensation (Associated with Tingling or Numbness)

Extensive lesion of thalamus or neighbourhood; usually vascular.

Contralateral Loss Confined to All Exteroceptive Sensation

- Partial lesion of thalamus
- Lesion laterally situated in upper brainstem
- Associated with motor and cranial nerve involvement.

Contralateral Loss Confined to Proprioceptive Sensation

- Partial lesion of thalamus
- Lesion medially situated in upper brainstem.

Contralateral Loss of Position Sense and Cortical Sensation with Disturbance of Light Touch and Pain

Indicates parietal lobe lesion or a lesion between thalamus and cortex.

Contralateral Hyperalgesia and Hyperaesthesia

Partial lesions of thalamus.

Loss of Pain and Temperature on One Side of the Face and Opposite Side of the Body

Lesion of the medulla affecting the descending root of trigeminal nerve and the ascending spinothalamic tract from the rest of the body.

Lateral Medullary Syndrome (Wallenberg Syndrome)

This is due to thrombosis of posterior inferior cerebellar artery (PICA) or vertebral artery.

Bilateral Loss of All Forms of Sensation below a Definite Level

This occurs due to gross lesions of spinal cord. It is indicated by a zone of hyperaesthesia. Actual level of involvement may be many segments higher than sensory level suggests.

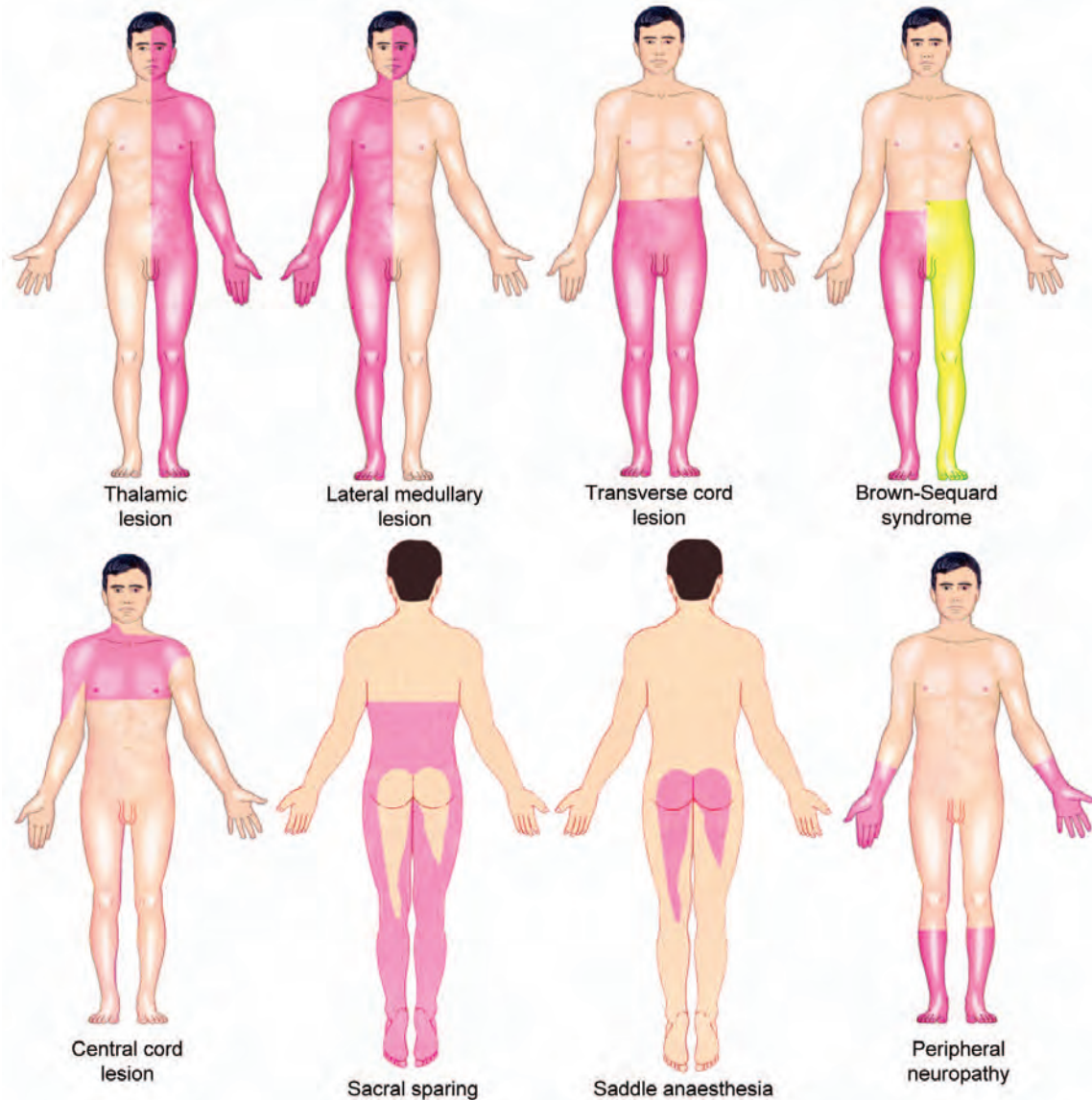

Fig. 8.74: Various sensory lesions

If pain and temperature only are affected, it denotes only anterior aspect of cord is involved (anterior spinal artery thrombosis).

Unilateral Loss of Pain and Temperature below a Definite Level (Brown-Sequard Syndrome/ Hemisection of Cord)

Ipsilateral motor and proprioceptive impairment and contralateral pain and temperature loss. There is a thin band of analgesia representing involvement of root entry zone. It is seen in cord compression, injury or demyelination.

Sacral Sparing

Sacral sparing refers to preservation of pin prick and temperature sensation in sacral dermatomes ($S_{3,4,5}$) in the presence of sensory loss at a higher level. This is a dependable sign of intrinsic cord compression damaging inner most fibres of spinothalamic tracts while sparing those placed more laterally which subserve sacral sensation.

Loss of Sensation of Saddle Type

Impairment of sensation over the lowest sacral segments when it affects all forms of sensation accompanied by



Symptoms and Signs of Sensory Lesions

Site	Symptoms	Signs	Associated features
Peripheral nerve (partial lesion)	Numbness Paraesthesiae	Reduced sensation in territory of nerve	Weakness of muscles supplied by nerve
Many peripheral nerves (polyneuropathy)	Numbness and paraesthesiae of hands and feet	'Glove and stocking' reduced sensation; impaired vibration at extremities	Weakness of distal muscles; loss of deep tendon reflexes
Spinal root (radiculopathy)	Numbness, paraesthesiae, hypersensitivity, 'tightness'	Reduced sensation ± hyperpathia in dermatomal pattern	Weakness of muscles and reduced tendon reflexes of that segment
Posterior column	Numbness and 'band-like' sensations, unsteadiness, clumsiness	Reduced joint position sense, vibration and 2-point discrimination, and touch ipsilaterally; normal pain and temperature	Sensory ataxia, loss of balance worse with closed eyes (Romberg's test)
Spinothalamic tract	Numbness, warmth, coldness diffuse distribution, contralaterally below lesion	Reduced pain and temperature, sensation below and contralateral to lesion, normal proprioception and vibration	Area of altered sensation begins several spinal segments below lesion
Brainstem (pons or lower)	Numbness and paraesthesiae face with coldness/warmth of opposite limbs and trunk	Ipsilateral facial anaesthesia, with contralateral loss of pain/temperature of limbs and trunk	Lower cranial nerve lesions ipsilateral (V, VI, VII, IX, X, XI, XII)
(Above pons)	Contralateral numbness or coldness/warmth face, limbs, trunk	Contralateral reduced touch, pain/temperature on face, limbs, trunk	Ipsilateral upper cranial nerve lesion (III, IV)
Thalamus	Diffuse deep pain on opposite side of body	Reduced touch, pain and temperature + hyperpathia contralaterally	Pain threshold raised, but more unpleasant
Internal capsule	Contralateral numbness of face, limbs, trunk	Reduced touch, pain, temperature on face, limbs and trunk on contralateral side	Hemiparesis or hemianopia if other parts of capsule involved
Sensory cortex	Numbness localised to limb or part of it	Loss of position sense, 2-point discrimination and stereognosis	Weakness of affected part if motor cortex is involved
Parietal lobe	Difficulty in identifying shape, size, texture; spatial disorientation	Impaired recognition of shapes, sizes; denial of limbs	Apraxia for purposeful movements, speech, dressing apraxia; spatial problems

loss of leg reflexes and sphincter control indicates major lesion of cauda equina.

If touch is preserved, lesion is near conus in which plantar reflexes may be extensor and knee jerks may be retained.

Glove and Stocking Anaesthesia

Loss of all forms of sensation over a clearly defined area in one part of the body only (glove and stocking distribution). This is due to lesion of peripheral nerve or sensory root, e.g. diabetes mellitus, polyneuropathy, mononeuritis multiplex, polyarteritis nodosa.

Loss of Vibration Sense Alone

If affecting lower limbs, intrinsic cord lesions like multiple sclerosis, syringomyelia should be thought of. It is lost in old age also.

Loss of Position and Vibration Sense Alone

This is due to lesion of posterior column as in tabes dorsalis, subacute combined degeneration, Friedreich's ataxia, also in carcinomatous and toxic (mercury) neuropathy.

If lost below a level, suggests compression of posterior part of the cord. If arms are affected much greater than legs and asymmetrically, think of cervical spondylotic myelopathy or foramen magnum lesions.

Patchy Areas of Sensory Loss

It suggests chronic polyneuritis (recovery phase), leprosy, tabes dorsalis, mononeuritis multiplex and arachnoiditis.

In parietal lobe involvement, there is contralateral hemineglect, hemi-inattention and a tendency not to use contralateral arm or hand. Dysesthesias are unusual.



They are present only in focal sensory seizures. Seizures may last for a few seconds or hours and may be associated with motor features. They can occur unilaterally in lip, face, digits or foot or may spread as in Jacksonian march.

If bilateral, there is involvement of rolandic area at and just above the Sylvian fissure.

Dejerine Roussy Syndrome

It is a hemipainful state (like the flesh being torn from the limbs) occurring in lesions of thalamus.

Epilepsy

Epilepsy is defined as a group of disorders in which there are recurrent episodes of altered cerebral function associated with paroxysmal excessive and hypersynchronous electrical discharge of cerebral neurons. Each episode of neurologic dysfunction is called seizure, which may be convulsive or nonconvulsive.

Classification of Epileptic Seizures

1. **Partial Seizures**
 - a. Simple partial seizure (with motor/sensory/autonomic/Psychic signs)
 - b. Complex partial
 - c. Partial seizure with secondary generalisation
2. **Primarily Generalised Seizures**
 - a. Absence (Petit mal)
 - b. Tonic-clonic (Grand mal)
 - c. Tonic
 - d. Atonic
 - e. Myoclonic
3. **Unclassified Seizures**
 - a. Neonatal seizure
 - b. Infantile spasms
4. **Status Epilepticus**
 - a. Tonic-clonic
 - b. Absence status
 - c. Epilepsia partialis continua.
5. **Reflexly Induced Seizures**
 - a. Specific precipitants
 - b. Non-specific precipitants.

Precipitating Factors for Epilepsy

1. Common
 - a. Sleep deprivation
 - b. Emotional stress
 - c. Physical and mental exhaustion
 - d. Infection and pyrexia

- e. Drug or alcohol ingestion or withdrawal
- f. Flickering light, visual patterns (proximity to TV screen).
- g. Hormonal changes associated with menstruation
2. Uncommon
 - Loud noise, music, hot baths, reading.



Causes

Generalised seizures

1. Primary (idiopathic) of genetic origin; There is a positive family history.
2. Secondary causes
 - a. Infections
 - Meningitis
 - Encephalitis
 - Abscesses
 - Subdural empyema
 - Syphilis
 - Tuberculosis
 - HIV
 - Toxoplasmosis
 - Cysts
 - b. Vascular
 - Malformations
 - Aneurysms
 - Infarction
 - Haemorrhage
 - c. Trauma
 - Head injury
 - Birth injury
 - d. Anoxia
 - e. Metabolic
 - Hypocalcaemia
 - Hyponatraemia
 - Hypoglycaemia
 - Porphyria
 - Hypoxia
 - Renal and hepatic failure
 - f. Drugs and toxins
 - Alcohol
 - Antidepressants
 - Phenothiazines
 - Amphetamine
 - Local anaesthetics
 - Metronidazole
 - g. Collagen vascular disease and miscellaneous
 - SLE
 - Sarcoidosis
 - Storage disorders.
 - h. Tumours



Clinical Features

1. **Partial Seizures: Can Be Simple or Complex**
 1. *Simple Partial Seizures*
 - a. *Motor:* Seizure starting in one part of the body and spreading gradually to involve the whole



side is known as Jacksonian epilepsy. Paresis or paralysis of muscles of affected limb lasting for several hours after prolonged episodes of seizures is known as Todd's palsy. Todd's palsy is a sign of focal origin of seizure activity.

- b. *Sensory*: Seizure is perceived as tingling or electric sensation in the contralateral face and limbs.
 - c. *Versive*: Forced deviation of the eyes to the opposite side due to frontal epileptic focus (frontal eye field).
 - d. *Visual*: Occipital epileptic focus causing visual hallucinations.
 - e. *Psychomotor*:
 - i Seizure manifests as alteration of mood, memory and perception (arise from medial temporal lobe).
 - ii. It is a common form of seizure to produce both partial and secondary seizure.
 - iii. Simple partial temporal lobe seizures produce disorder of perception
 - Undue familiarity (deja vu)
 - Unreality (jamais vu)
 - Complex hallucination of sound, smell, taste, vision
 - Emotional changes
 - Visceral sensations like nausea, epigastric discomfort can occur.
2. *Complex Partial Seizures*
 - a. Preceded by aura (lasting for seconds or minutes)
 - b. Loss of awareness (lasting for several minutes)
 - c. Patient may stare and be unresponsive to questions
 - d. Automatic movements (lip smacking, swallowing).

II. Generalised Seizure (Grand mal)

This is a common form of epilepsy. It consists of

Phase	Duration
Prodromal phase	several hours or days
Aura	seconds or minutes
Tonic phase	10–30 seconds
Clonic phase	1–5 minutes
Post-ictal phase	a few minutes to hours

III. Classic Absence (Petit mal)

This is an uncommon form of epilepsy and is mostly seen in children. Child suddenly stops activity, stares, may blink, roll up the eyes and fail to respond to commands. The attack lasts for only a few seconds.

IV. Reflexly Induced Seizure

It can occur sporadically or randomly with or without apparent triggering pattern.

With Specific Precipitants

- a. Photomyoclonic or photoconvulsive epilepsy (triggered by photic stimulation)
- b. Musicogenic epilepsy (triggered by specific musical compositions)
- c. Somatosensory induced epilepsy (tactile stimulation)
- d. Reading or language epilepsy (induced by reading)

It usually consist of brief myoclonic jerks of the jaw, cheek and tongue which can occur during silent/oral reading and may progress to generalised tonic clonic convulsion.

With Non-specific Precipitants

*Catamenial epilepsy and epilepsy in concert with sleep waking cycle.

Note: *Associated with menstrual cycle.



Investigations

1. Routine tests (blood urea, sugar, serum creatinine, electrolytes)
2. Liver function tests
3. Tests for syphilis and HIV
4. ECG
5. EEG
 - a. Routine
 - b. Sedated
 - c. 24-hour ambulatory ECG or EEG.

In petit mal epilepsy, bilateral synchronous spike and wave complexes at a frequency of 3/second.
6. *CT scan*: It is indicated in the following conditions (Figs 8.75 to 8.78):
 - a. Epilepsy starting after the age of 20 years
 - b. Clinical evidence of focal features of seizures (in all ages)
 - c. EEG evidence of focal seizure
 - d. Uncontrollable seizures or deterioration of clinical conditions
 - e. Change in the pattern of epilepsy in a known epileptic.
7. *MRI*: It is superior to CT in scanning for the detection of cerebral lesions associated with epilepsy.
8. *PET/SPECT*: Used in the evaluation of patients with medically refractory seizures.

PET—Positron Emission Tomography
SPECT—Single Photon Emission Computerised Tomography.

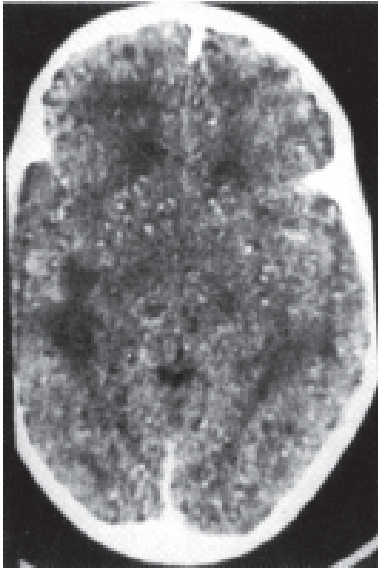

Fig. 8.75: CT brain—neurocysticercosis (*starry sky* pattern)

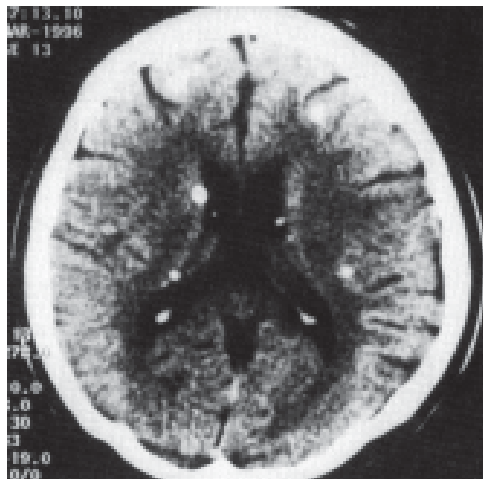

Fig. 8.76: CT brain—calcified lesions of cysticercosis

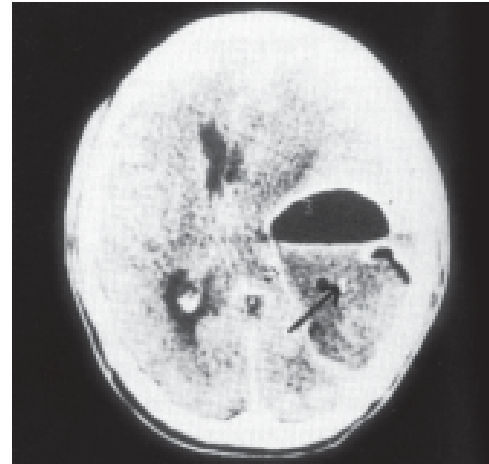

Fig. 8.77: CT brain—right cerebral abscess (anaerobic infection)

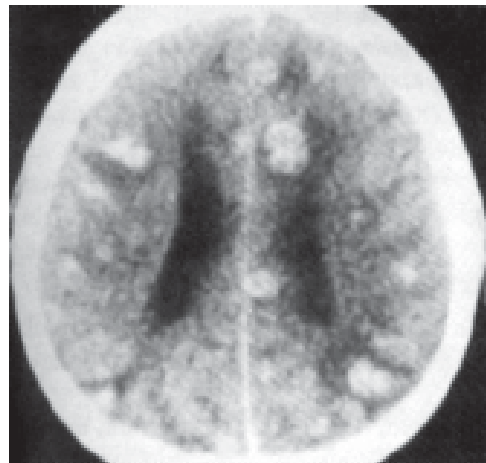

Fig. 8.78: CT brain—tuberculomas

9. Magnetic Encephalography (MEG)

- Non-invasive
- To measure magnetic field produced by seizure activity
- These source estimates can then be plotted on an anatomic image of the brain such as an MRI, to generate a magnetic source imaging to locate seizure foci



Management

Immediate Treatment

1. Keep the patient away from danger (fire, water, machinery).

2. Keep the airways clean and turn the patient to semi-prone position.
3. Keep a padded gag or rolled handkerchief between the teeth to prevent tongue bite.

Principles of Anticonvulsants

1. Begin with a single drug in a small dose and increase gradually over a period of 4–6 weeks.
2. The drug dosage should be adjusted with the minimal level of the therapeutic range and can be increased to maximal tolerable range in uncontrolled seizures.
3. Try 3 single drugs individually before changing into drug combination.
4. During the change to new drug, the initial drug may be gradually reduced.
5. The withdrawal of drug may be considered after 2–4 years of complete control of seizures.



Anticonvulsants

Drugs	Dosage	Side effects	Uses
Phenytoin	300–400 mg/day or 3–5 mg/kg	Ataxia, in-coordination, confusion, cerebellar signs, skin rashes, gum hyperplasia, lymphadenopathy, hirsutism, osteomalacia	Tonic-clonic (grand mal), partial seizures
Carbamazepine	600–1200 mg/day or 20–30 mg/kg	Ataxia, dizziness, diplopia, vertigo, bone marrow suppression, gastrointestinal irritation, hepatotoxicity	Tonic-clonic (grand mal), partial seizures
Phenobarbitone	60–120 mg/day or 1–5 mg/kg body weight	Sedation, ataxia, confusion, dizziness, decreased libido, depression, and skin rashes	Tonic-clonic (grand mal), partial seizures
Primidone	750–1000 mg/day (10–25 mg/kg)	Same as phenobarbitone	Tonic-clonic (grand mal), partial seizures
Sodium valproate (valproic acid)	750–1250 mg/day (30–60 mg/kg)	Ataxia, sedation, tremor, hepatotoxicity, bone marrow suppression, gastrointestinal irritation, alopecia and hyperammonemia	Absence seizures (typical & atypical), myoclonic seizures
Felbamate	3600 mg/day	Insomnia, headache, dizziness, gastrointestinal irritation, nausea, anorexia	Partial, secondary generalised seizures
Ethosuximide	750–1250 mg/day (20–40 mg/kg/day)	Ataxia, lethargy, gastrointestinal irritation, skin rash, bone marrow suppression	Absence (petitmal) seizures
Clonazepam	1–12 mg/day (0.1–0.2 mg/kg/day)	Ataxia, sedation, lethargy, anorexia	Absence (typical & atypical) seizures, myoclonic seizures
Lamotrigine	300–500 mg/day	Headache, dizziness ataxia, diplopia, skin rash, nausea	Partial seizures
Gabapentine	900–1200 mg and upto 2400 mg	Dizziness, somnolence, ataxia, gastrointestinal irritation	Partial seizures
Topiramate	400 mg/d BD	Sedation, speech problem, paraesthesia, renal calculi	Partial, tonic-clonic
Tiagabine	30-60 mg/d BD-QID	Sedation, speech problem, paraesthesia, psychosis	Partial, tonic-clonic, Lennox-Gastaut syndrome
Levetiracetam	1-3 g/d BD	Sedation, incoordination, psychosis anaemia, leucocytopenia	Partial
Zonisamide	200-800 mg/d	Sedation, confusion, anorexia renal calculi	Partial
Oxcarbazepine	900-2400 mg/d BD	Same as carbamazepine	Partial

Drugs of Choice in Seizure Disorder

	Primary generalised tonic-clonic	Partial	Absence	Atypical absence myoclonic, atonic
<i>First line</i>	Valproic acid Lamotrigine Topiramate	Carbamazepine Phenytoin Valproic acid Lamotrigine Oxcarbamazepine	Ethosuximide Valproic acid	Valproic acid Lamotrigine Topiramate
<i>Alternatives</i>	Phenytoin Carbamazepine Primidone Phenobarbitone Felbamate	Gabapentin Topiramate Tiagabine Primidone Phenobarbitone	Lamotrigine Clonazepam	Clonazepam Felbamate



6. Absence seizure in childhood carries good prognosis for successful drug withdrawal.
7. To withdraw anticonvulsants in adults is to decrease the dose by 10% every four weeks for carbamazepine, phenytoin, and valproate and by 10% every eight weeks for phenobarbitone, benzodiazepines and ethosuximide.

Precautions after the Seizure Attack

1. Avoid cycling and swimming until at least 6 months of freedom from seizure (Driving is allowed after 2 years of good control of seizure)
2. Swimming should be always in the company of someone who is aware of his seizure disorder
3. Avoid activity in places where communication is difficult (mountaineering).



Treatment of Refractory Epilepsy

Vagus nerve stimulation

This involves the placement of a bipolar electrode on the mid-cervical portion of the left vagus nerve. The mechanism of action may be the stimulation of vagal nuclei leading to activation of cortical and subcortical pathways and an associated increased seizure threshold.

Surgery

Temporal lobectomy and lesionectomy can be done.

Hemispherectomy and Stereotactic radio-surgery can also be useful in some cases.

Status Epilepticus

It is defined as a state in which the patient suffers a series of seizures without fully recovering consciousness between these seizures.

Duration : 15–30 minutes.

Classification

1. Convulsive status
 - a. Generalised tonic clonic status
 - b. Partial (epilepsia partialis continua)
2. Nonconvulsive status
 - a. Absence status
 - b. Complex partial seizures (psychomotor)
 - Prolonged convulsive seizures lasting for 30 minutes should also be treated similarly.
 - Nonconvulsive status and convulsive status of brief duration do not warrant aggressive combination drug therapy. In the above situations, single anticonvulsant and supportive measures may be adequate.

Precipitating Factors

Structural Abnormalities

1. Trauma
2. Tumours
3. Central nervous system infections
4. Cerebrovascular disorders.

Nonstructural

1. Hypoglycaemia
2. Hyperglycaemia (Nonketotic hyperosmolar coma)
3. Hyponatraemia
4. Hypocalcaemia
5. Uraemia
6. Anoxia
7. Alcohol
8. Sedative drug withdrawal
9. Drug intoxication (theophylline, amphetamine, INH).

Most common cause in children—idiopathic.

Most common cause in adults—noncompliance or subtherapeutic level of anticonvulsants.

Aetiology

1. Abrupt withdrawal of antiepileptic drugs in a known epileptic patient
2. Cerebrovascular disease due to venous thrombosis
3. Meningoencephalitis
4. Metabolic disturbance
5. Alcohol withdrawal
6. Hypertensive encephalopathy.



Complications

1. Anoxia
2. Hyperthermia
3. Acidosis
4. Hypoglycaemia
5. Cardiac dysrhythmias
6. Reflex pulmonary oedema
7. Rhabdomyolysis
8. Myoglobinuria
9. Aspiration pneumonia
10. Shock.



Management

1. Maintenance of airway, breathing and circulation.
2. Routine tests for blood urea, sugar, creatinine and electrolytes.



3. Inj Lorazepam 0.1 mg/kg at 2 mg/min, up to 4 mg or inj Diazepam 0.2 mg/kg at 5 mg/min, up to 10 mg.
It can be repeated after 5 minutes.
4. Administration of long-acting anticonvulsants like inj Phenytoin 20 mg/kg as loading dose, followed by maintenance dose of 5-10 mg/kg at 50 mg/mt, given via glucose free IV fluid to avoid precipitation in the tubing. Watch for arrhythmias.
Sodium valproate 25 mg/kg IV can be given.
5. Wait for 15-20 min, if seizure continues give inj Phenobarbitone 20 mg/kg at the rate of <50 mg/min. If the seizures are still uncontrolled, additional dose of 5-10 mg/kg may be given. Watch for arrhythmias and hypotension.
6. In some patients continuous Diazepam infusion is preferred. IV infusion can be given at a rate of 10-50 mg/hr in an IMCU set-up with respiratory support.
7. If seizures still persist general anesthesia with neuromuscular blockade is required (IV midazolam, pentobarbital).
8. Once the status has been successfully treated, causative factors are identified and managed and anticonvulsants are maintained.
(Phenytoin 4-7 mg/kg/d, Phenobarbitone 1-5 mg/kg/d IV or oral BD).
4. Effects of tonic-clonic seizures on the fetus during pregnancy are not well established. However, tonic-clonic convulsions might be deleterious to the fetus, injure the mother, and lead to miscarriage.
5. The diet before conception should contain adequate amounts of folate.
6. If the patient is seizure free for at least 2 years (e.g. free from absences, complex partial, or tonic-clonic attacks), withdrawal of AED should be considered.
7. If AED treatment is necessary, a switch to monotherapy should be made if possible.
8. The lowest AED dose and plasma level that protects against tonic-clonic, myoclonic, absence, or complex partial seizures should be made if possible. Closed-circuit television electroencephalographic monitoring should be used if necessary.
AED = antiepileptic drug.

Guidelines for Antiepileptic Drug (AED) Use during Pregnancy

1. Use first-choice drug for seizure type and epilepsy syndrome.
2. Use AED as monotherapy at lowest dose and plasma level that protects against tonic-clonic seizures.
3. Avoid valproate and carbamazepine when there is a family history of neural tube defects.
4. Avoid polytherapy, especially the combination of valproate, carbamazepine, and phenobarbital.
5. Monitor plasma AED levels regularly and, if possible, free or unbound plasma AED levels.
6. Continue folate daily supplement, and ensure normal plasma and red cell folate levels during the period of organogenesis in the first trimester.
7. In cases of valproate treatment, avoid high plasma levels of valproate. Divide doses over 3-4 administrations per day.
8. In cases of valproate or carbamazepine treatment, offer amniocentesis for α -fetoprotein at 16 wk and real-time ultrasonography at 18-19 wk, looking for neural tube defects. Ultrasonography at 22-24 wk can detect oral clefts and heart anomalies.
9. Folate supplementation (1-4 mg)/day is essential.

Epilepsy in Pregnant Women

Epilepsy in pregnant women is a special situation where the following guidelines may be observed.

- 50% - No alteration of seizure frequency
- 30% - Seizure frequency increases
- 20% - Seizure frequency decreases

Guidelines for Counseling Women with Epilepsy who Plan Pregnancy

1. The risk of major malformations, minor anomalies, and dysmorphic features are two-fold to three-fold higher in infants of mothers with epilepsy who receive treatment with AEDs compared with the risk in infants of mothers without epilepsy.
2. A possibility exists that some of the risk is caused by a genetic predisposition for birth defects inherent in certain families. Both parents' family histories should be reviewed for birth defects.
3. Possibilities for prenatal diagnosis of major malformations should be discussed. If valproate or carbamazepine is the necessary AED, the likelihood of amniocentesis and ultrasound examinations during pregnancy should be discussed. Ultrasound examination for a variety of major malformations can be done during 18-22 weeks.

Catamenial Epilepsy

- Epilepsy occurring during menstruation
- Reflects either the effects of estrogen and progesterone on neuronal excitability or alteration in the antiepileptic drugs due to altered protein binding.
- *Management:* Acetazolamide 250-500 mg/day - 7-10 days before cycles.
Add OCP to decrease cycles and increase the antiepileptic drugs.



Pseudoseizures

1. It is characterised by non-physiological events such as progression of twitching from one hand to the other without spread to subjacent ipsilateral face or leg area, twitching of all four extremities without loss of consciousness.
2. The twitching does not resemble tonic clonic convulsion.
3. It is seen mostly in adolescent girls who have sexual overtones, with pelvic thrusting or genital manipulation.
4. The EEG is normal.
5. There is no change in the level of serum prolactin (Usually rise during a 30 minutes postictal period in tonic clonic and complex partial seizure).
6. The patient having pseudoseizure will avoid injury by moving away from wall or bed edge during motor convulsions.

Neurocutaneous Syndromes

The major ones are considered:

Neurofibromatosis

NF 1 – (von Recklinghausen's disease)

Inherited as autosomal dominant and the affected chromosome is 17.

Diagnosis is made if two of the following criteria are found.

1. > 6 café-au-lait macules of > 5 mm in size (Prepubertal) (Fig. 8.79) or >15 mm size (postpubertal)
2. > 2 neurofibromas of any type or 1 plexiform type
3. Freckling in the axillary or inguinal region
4. Optic gliomas
5. >Two Lisch nodules
6. Distinctive osseous lesion typical of NF 1 (Sphenoidal dysplasia)



Fig. 8.79: Neurofibroma with café-au-lait spot

7. First degree relative with NF 1 according to the above criteria.

NF 2

Diagnosis is made if either of the following are found:

1. Bilateral vestibular schwannoma seen on MRI or CT
2. First degree relative with NF 2 and either
 - a. Unilateral vestibular schwannoma
 - b. One of the following
 - Neurofibroma
 - Meningioma
 - Glioma
 - Schwannoma
 - Juvenile posterior subcapsular cataract

Tuberous Sclerosis

Inherited as autosomal dominant and the affected chromosomes are 16 p 13.3 (TSC 2) and 9 q 34 (TSC 1)

1. Characterised by seizures, cutaneous lesion and mental retardation
2. Adenoma sebaceum—facial angiofibromas (most common cutaneous manifestations) (Fig. 8.80)

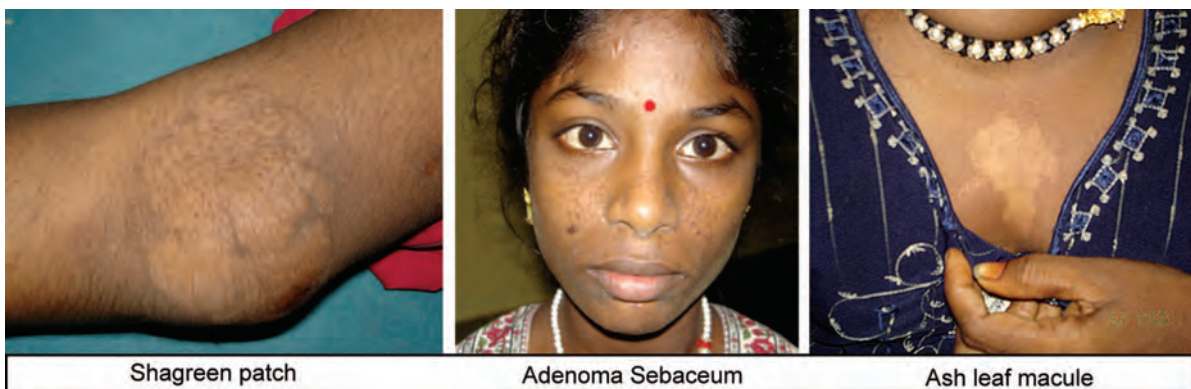

Shagreen patch

Adenoma Sebaceum

Ash leaf macule

Fig. 8.80: Tuberous sclerosis

3. Ash leaf hypo-pigmented macules (earliest manifestation) (Fig. 8.80)
4. Shagreen patch—Yellowish thickening of the skin over the lumbo-sacral region (Fig. 8.80)
5. Calcified sub-ependymal nodules
6. Rhabdomyomas of the myocardium
7. Angiomyomas of the kidneys, liver, pancreas, and adrenals
8. Increased risk for developing ependymomas and astrocytomas.

Von Hippel Lindau Syndrome

Inherited as autosomal dominant and the affected chromosome is 3.

1. Retinal, cerebellar, and spinal haemangioblastoma
2. Renal cell carcinoma
3. Pheochromocytomas
4. Cysts and tumours of kidney, pancreas, liver and epididymis.

Sturge-Weber Syndrome

1. Facial naevus flammeus—along the distribution of ophthalmic division of Vth nerve
2. Contralateral focal seizures
3. Calcification of the cortex and sub-cortical structures
4. Glaucoma on the same side of skin lesion.

Ataxia Telangiectasia

Inherited as autosomal recessive and the affected chromosome is 11.

1. Progressive cerebellar ataxia
2. Oculo-cutaneous telangiectasia (Fig. 8.81)
3. Pulmonary and sinus infections



Fig. 8.81: Telangiectasia-bulbar conjunctiva

4. Immunodeficiency
5. Choreo-athetosis
6. Predisposition to lymphoreticular malignancy.

All the neurocutaneous syndromes are inherited except Sturge-Weber syndrome.

All the neurocutaneous syndromes are inherited as autosomal dominant except ataxia telangiectasia which is inherited as autosomal recessive.

Cerebrovascular Disorders

Stroke

Stroke is an acute neurologic injury occurring as result of vascular pathologic processes which manifest either as brain infarction or haemorrhage.

Major Causes

- Age
- Obesity
- Hypertension
- Smoking
- Diabetes mellitus
- Atrial fibrillation
- Heart disease
- Dyslipidaemia
- Hyperfibrinogenaemia
- Alcohol
- Coagulopathies
- Contraceptive pill
- Markers of arterial atheroma (TIA, Angina, Claudication, Bruits).

Haematological Causes

- Polycythaemia
- Thrombocythaemia
- Thrombotic thrombocytopenic purpura
- Sickle cell disease
- Paroxysmal nocturnal haemoglobinuria
- Lupus anticoagulant
- Protein C deficiency
- Protein S deficiency
- Antithrombin III deficiency
- Leukaemias
- Homocysteinaemia.

Cardiac Causes

- Rheumatic valve disease
- Atrial fibrillation
- Prosthetic heart valves
- Myocardial infarction/Ventricular aneurysm



- Atrial aneurysm/Mitral valve prolapse
- Calcific aortic valve
- Cardiomyopathy
- Bacterial endocarditis
- Patent foramen ovale
- Mitral annular calcification
- Cardiac operations.

Unusual Causes

- Marfan's syndrome
- Marantic endocarditis
- Meningovascular syphilis
- Moya moya disease
- Mitochondrial cytopathy (MELAS)
- AIDS
- Arterial dissection
- Ehlers-Danlos syndrome
- Fibromuscular dysplasia
- Pseudoxanthoma elasticum
- Fabry's disease
- Scleroderma
- Collagen vascular disease
- Hanging/strangulation
- Drug abuse
- Cervical irradiation.

Clinical Classification of Stroke

1. *Completed stroke*: This is rapid in onset with persistent neurological deficit which does not progress beyond 96 hours.
2. *Evolving stroke*: There is a gradual step-wise development of neurological deficit.
3. *Transient ischaemic attack*: The focal neurological deficit resolves completely within 24 hours
4. *Reversible ischaemic neurological deficit (RIND)*: The neurological deficit completely resolves within a period of 1 to 3 weeks.

Types	Percentage
<i>Cerebral infarction (80%)</i>	
Large vessel occlusions	50%
Small vessel (lacunar) infarcts	25%
Cardiac emboli	15%
Blood disorders	5%
Vasculitis/vasculopathy	5%
<i>Primary intracerebral haemorrhage (15%)</i>	
Hypertensive bleeds	60%
Amyloid angiopathy	20%
Vascular malformations	15%
Bleeding diathesis/anticoagulants	5%
<i>Non-traumatic SAH (5%)</i>	
Aneurysms	80%
Vascular malformations	10%
"Non-aneurysmal" SAH	10%

Risk Factors for Stroke

Major

1. Hypertension
2. Smoking
3. Diabetes mellitus
4. Obesity
5. Hyperlipidaemia
6. Polycythaemia
7. High plasma fibrinogen
8. Cardiac lesion
 - Atrial fibrillation
 - Mitral valve prolapse
 - Mitral stenosis
 - Rheumatic heart disease
 - Ischaemic heart disease
 - Infective endocarditis.
9. Thrombocythaemia.

Minor

1. High alcohol intake
2. Positive family history of stroke
3. Oral contraceptive pills
4. Trauma.

Pathophysiology of Stroke

1. Cerebral infarction
 - a. Thrombosis at the site of atheroma
 - b. Embolism from major arteries (aorta, internal carotid artery, vertebral arteries)
 - c. Thromboembolism from heart (from left atrium-mitral stenosis, myxoma, MVP; from left ventricle-mural thrombus as a result of infarction; paradoxical embolism).
2. Cerebral haemorrhage
 - a. Intracerebral (in the presence of hypertension)
 - b. Subarachnoid (in the presence of intracranial artery aneurysms).

Transient Ischaemic Attacks

TIA can be of 3 types:

1. *Low flow TIAs*: These are brief, recurrent and stereotyped. These may be associated with atherosclerotic lesion at the internal carotid artery (ICA) origin or intracranial portion of ICA, MCA stem, junction of vertebral and basilar arteries.
2. *Embolic TIAs*: These are discrete, usually single, and can be more prolonged. If they last for more than 24 hours, it indicates that an infarction has already occurred.
3. *Lacunar or penetrating vessel TIAs*: This is due to occlusion of small vessels as a result of lipohyalinosis in response to hypertension or atheroma.

Crescendo TIAs are those occurring in increased number and frequency and having a high likelihood of evolving into stroke.



Differential Diagnosis of TIA

1. Migraine
2. Epilepsy
3. Mass lesions
4. Multiple sclerosis
5. Hypoglycaemia
6. Hypertensive encephalopathy.

Stroke can involve either carotid territory or vertebrobasilar territory.

Carotid territory: Stroke occurring in carotid arterial territory results in mono-ocular visual disturbance, speech disorders, UMN type of VIIth nerve lesion, hemiplegia, hemianaesthesia (cortical type), or hemianopia. Unilateral involvement of auditory radiation does not cause deafness.

Vertebrobasilar territory: Stroke occurring as a result of involvement of vertebrobasilar territory causes lower cranial nerve involvement, with unilateral or bilateral hemiplegia. It presents with

- Diplopia
- Dizziness (vertigo)
- Drop attacks
- Dysphagia/dysarthria
- Bipyramidal signs (double hemiplegia)
- Cortical blindness
- Thalamic syndrome.

Stuttering Hemiplegia

Internal carotid lesions are characterised by repeated episodes of TIA followed by fully evolved stroke.

Cerebral Blood Supply

The entire cerebrum is supplied by anterior, middle and posterior cerebral arteries (Fig. 8.82).

Anterior cerebral artery (ACA): It is one of the terminal branches of internal carotid artery. It supplies the entire medial surface of cerebral hemispheres including a strip of cortex for about 2 cm along the superolateral surface and medial half of orbital surface except the occipital lobe.

Recurrent artery of Heubner is an important branch of ACA and its involvement causes faciobrachial monoplegia.

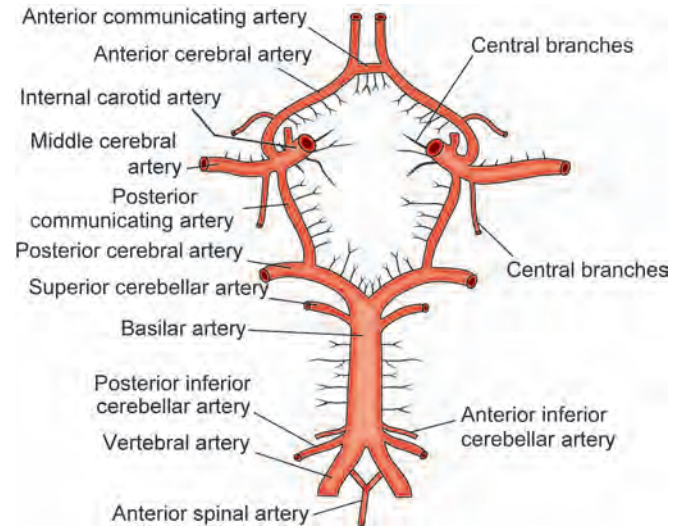

Fig. 8.82: Circle of Willis

Middle cerebral artery (MCA): MCA supplies the entire lateral surface of cerebrum including lateral half of orbital surface except

- a. Frontal pole and a strip of cortex for about 2 cm along superolateral surface of frontal lobe
- b. Medial half of orbital surface (a and b are supplied by ACA)
- c. Lower temporal and occipital pole (which is supplied by PCA).

In the Sylvian fissure, MCA divides into superior and inferior division.

Posterior cerebral artery (PCA): PCA supplies the medial surface of temporal and occipital lobes and their tentorial surface. It also supplies cerebellum, medulla, pons, mid brain, subthalamus, and thalamus.

Vertebral Artery

This artery arises from first part of subclavian artery. It can be divided into four segments.

First segment: From the site of origin to its entry into transverse foramen of C₅ or C₆ vertebra.

Second segment: Traversing through the transverse foramina of C₆ to C₂ vertebrae.

Third segment: Artery winds around atlas and pierces dura mater.

Fourth segment: After piercing dura, joins with the opposite vertebral artery to form basilar artery.

The branches are:

1. Meningeal branches
2. Posterior spinal arteries



3. Anterior spinal artery
4. Posterior inferior cerebellar artery
5. Medullary arteries.

Basilar Artery

This artery ascends in a groove on the anterior surface of the pons and gives rise to the following branches before dividing into posterior cerebral arteries. The branches are:

1. Pontine arteries
2. Labyrinthine artery
3. Anterior inferior cerebellar artery
4. Superior cerebellar artery
5. Posterior cerebral arteries (terminal branches).

Blood Supply to Specific Brain Areas

Thalamus: It is supplied mainly by branches of the posterior communicating, basilar and posterior cerebral arteries.

Midbrain: It is supplied by posterior cerebral, superior cerebellar, and basilar arteries.

Pons: It is supplied by basilar and the anterior, inferior, and superior cerebellar arteries.

Medulla oblongata: It is supplied by the vertebral, anterior and posterior spinal, posterior inferior cerebellar, and basilar arteries.

Cerebellum: It is supplied by the superior cerebellar, anterior inferior cerebellar, and posterior inferior cerebellar arteries.

Corpus striatum: It is supplied by medial and lateral striate central branches of the middle cerebral artery.

Internal Capsule

It can be divided into superior and inferior halves. The superior half is supplied by lenticulostriate branches of MCA; in the inferior half, anterior limb is supplied by ACA through Heubner's recurrent branch. The anterior third of posterior limb is supplied by posterior communicating artery and posterior two thirds are supplied by anterior choroidal artery.

ACA supplies bladder and leg areas.

MCA

Superior division supplies Broca's area
 Inferior division supplies Wernicke's area
 Lenticulostriate arteries supply superior half of internal capsule.

PCA supplies mainly visual cortex, brainstem, thalamus, a part of cerebellum.

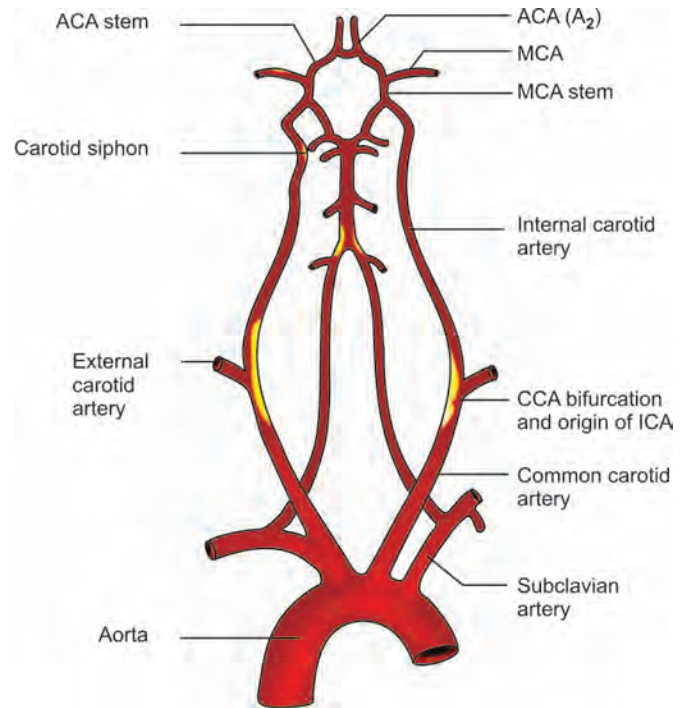

Fig. 8.83: Common sites of atherosclerotic plaques

Atherosclerosis (Fig. 8.83)

The most common sites of affection are—origin of ICA, within first 2 cm, siphon of ICA, proximal segment of MCA or ACA.

First and fourth segments of vertebral artery and top of basilar artery are commonly involved.

Occlusion of Internal Carotid Artery

Patients may have “amaurosis fugax”—transient mono-ocular blindness. A nonstenotic or slightly stenotic carotid lesion in association with a stroke or single prolonged TIA suggests heart as the source of embolus.

Occlusion of Middle Cerebral Artery (Fig. 8.84)

Occlusion is mainly due to embolus than thrombosis, since MCA is distal to circle of Willis, a major site of collaterals.

If there is occlusion at the stem, both cortical and penetrating branches are occluded resulting in contralateral hemiplegia, hemianaesthesia, and global aphasia. In nondominant hemisphere affection, patients have apractagnosias, anosognosia, and dysarthria.

Occlusion of proximal superior division of MCA causes sensory disturbance, motor weakness, and motor aphasia.

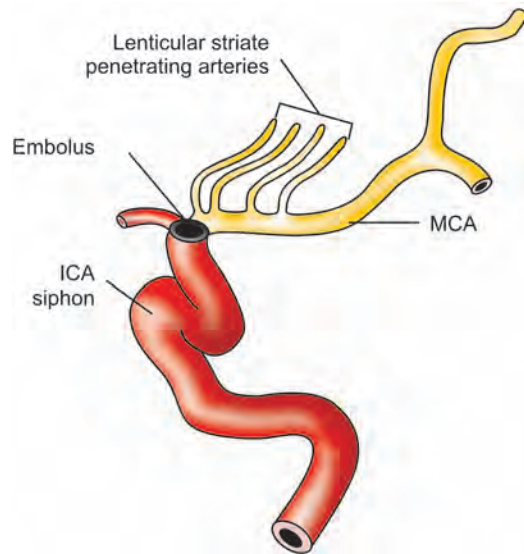

Fig. 8.84: MCA stem occlusion by embolus

Signs and symptoms	Structures involved
Paralysis of contralateral face, arm and leg	Somatic motor area
Sensory impairment over the same area	Somatic sensory area
Motor speech disorder	Broca's and adjacent motor area of the dominant hemisphere
Central aphasia, word deafness, anomia, jargon speech, alexia, agraphia, acalculia, finger agnosia, right left confusion	Central language area and parieto-occipital cortex of the dominant hemisphere
Homonymous hemianopia	Optic radiation deep to second temporal convolution
Paralysis of conjugate gaze to the opposite site	Frontal contraversive field
Agnosias (apractagnosia, anosognosia, agnosia for the left half of external space, hemiasomatognosia), apraxias (dressing apraxia, constructional apraxia), upside-down reading, visual illusions	Non-dominant parietal lobe (especially loss of topographic memory)
Miscellaneous: Pure motor hemiplegia	Superior half of the internal capsule and the adjacent corona radiata

Occlusion of inferior division of MCA causes Wernicke's aphasia without weakness; often with superior

quadrantanopsia; if there is involvement of non-dominant hemisphere, hemineglect and spatial agnosia without weakness can occur.

Occlusion of anterior cerebral artery: If anterior communicating artery is congenitally atretic, or if atheromatous lesion occurs in distal anterior cerebral artery, TIAs and strokes can occur.

Occlusion can be either at precommunal segment (A_1)/stem connecting ICA to anterior communicating artery or postcommunal segment (A_2)/distal to anterior communicating artery.

Occlusion of A_1 segment is well-tolerated because of collateral flow. If both A_2 segments arise from a single ACA due to contralateral A_1 segment atresia, the occlusion affects both hemispheres (*unpaired ACA*).

Patients have profound abulia (delayed motor and verbal response), bilateral pyramidal signs, paraplegia.

Occlusion of A_2 Segment Results in the Following

Signs and symptoms	Structures involved
Paralysis of opposite foot and leg	Motor leg area
Paresis of opposite arm	Involvement of arm area of cortex or corona radiata
Cortical sensory loss over toes, foot and leg	Sensory area for foot and leg
Urinary incontinence (cortical uninhibited bladder or incomplete spastic bladder)	Superior frontal gyrus (bilateral)
Contralateral grasp and sucking reflexes, gegenhalten (paratonic rigidity), 'frontal tremor'	Medial surface of the posterior frontal lobe
Abulia, delay or lack of spontaneity, motor inaction, reflex distraction to sights and sounds	Superomedial lesion near subcallosum
Impairment of gait and stance	Inferomedial frontal-striatal region
Miscellaneous: dyspraxia and tactile agnosia in left limbs	Corpus callosum

Motor leg area if bilaterally affected due to occlusion of anterior cerebral arteries or unpaired ACA results in paraplegia with cortical sensory loss.

Posterior Cerebral Artery

In 70%, both PCAs arise from bifurcation of basilar artery; in 22%, one from ipsilateral ICA and in 8% both are from ipsilateral ICA.



Peripheral Territory (Cortical Branches)

Signs and symptoms	Structures involved
Homonymous hemianopia with macular sparing	Calcarine cortex
Bilateral homonymous hemianopia, cortical blindness, denial of blindness, apraxia of ocular movements, inability to count	Bilateral occipital lobe with involvement of parieto-occipital region
Dyslexia without agraphia, color anomia	Dominant calcarine lesion, posterior part of corpus callosum
Memory defect	Inferomedial portion of temporal lobe bilaterally or on dominant side
Topographic disorientation and prosopagnosia	Nondominant calcarine and lingual gyri, usually bilateral
Simultagnosia	Dominant or bilateral visual cortex

Central Territory (Perforating Branches)

Signs and symptoms	Structures involved
<i>Thalamic syndrome:</i> All modalities of sensory loss, spontaneous pain, dysesthesias, choreoathetosis, intention tremor, mild hemiparesis	Ventral posterolateral nucleus of thalamus (thalamogeniculate artery), subthalamic nucleus or its pallidal connections
<i>Thalamoperforate syndrome:</i> Crossed cerebellar ataxia with ipsilateral third nerve palsy (Claude syndrome)	Dentatothalamic tract and issuing third nerve
<i>Weber's syndrome:</i> Ipsilateral III Nerve palsy + contralateral hemiplegia Contralateral ataxia or postural tremor (rubral tremor)	Cerebral peduncle + III nerve Dentatothalamic tract after decussation
Paralysis of vertical eye movement, skew deviation, sluggish pupillary response to light, slight miosis and ptosis	Supranuclear fibres to third nerve, high mid-brain tegmentum ventral to superior colliculus

Atheroma in PCA, distal to the junction of posterior communicating artery may occlude small circumferential branches.

Occlusion of PCA causes serious neurological deficits as important structures are involved (brainstem).

PCA occlusion can be either in the central territory or in the peripheral territory.

Occlusion proximal to posterior communicating artery may be asymptomatic or have only transitory effects if the collateral flow is adequate.

Vertebral Artery Syndromes

Vertebral arteries are the chief arteries of medulla each supplying the lower three-fourths of the pyramid, the medial lemniscus, lateral medullary region, the restiform body (inferior cerebellar peduncle), and the posterior inferior part of the cerebellar hemisphere.

Lateral Medullary Syndrome

This is due to occlusion of any of the following vessels namely vertebral, posterior inferior cerebellar (PICA) or superior, middle, or inferior lateral medullary arteries.

Occlusion results in the following features

- On the side of lesion*
 - Pain, numbness, and impaired sensation over half the face (descending tract and nucleus of fifth nerve)
 - Ataxia of limbs, falling to side of lesion (cerebellum, olivocerebellar fibres, restiform body)
 - Vertigo, nausea, vomiting, nystagmus, diplopia, oscillopsia (vestibular nuclei)
 - Horner's syndrome (descending sympathetic tract)
 - Dysphagia, hoarseness, vocal cord paralysis, diminished gag reflex (ninth and tenth nerves)
 - Loss of taste (nucleus and tractus solitarius)
 - Numbness of ipsilateral arm, trunk, or leg (cuneate and gracile nuclei)
 - Hiccup
- On the opposite side*
Impaired pain and thermal sense over half of the body, sometimes face (spinothalamic tract).

Medial Medullary Syndrome

This occurs as a result of occlusion of vertebral artery or branch of vertebral or lower basilar artery. Patients have the following features:

- On the side of lesion*
 - Paralysis with atrophy of half of the tongue (twelfth nerve)
- On the opposite side*
 - Paralysis of arm and leg sparing face (pyramidal tract)
 - Impaired tactile and proprioceptive sense over half the body (medial lemniscus).

A combination of medial and lateral medullary syndromes can occur as a result of occlusion of vertebral artery (Fig. 8.85).

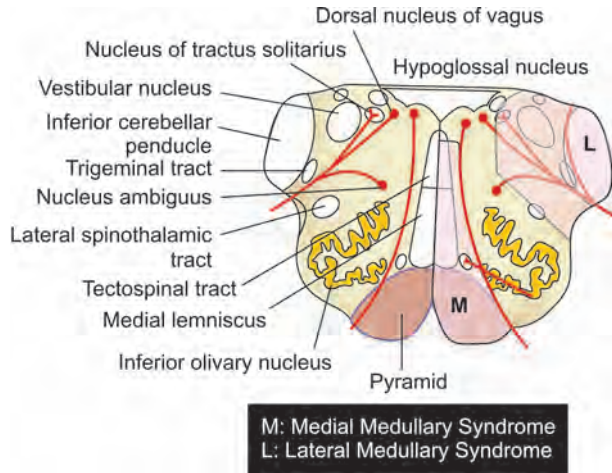

Fig. 8.85: Medullary syndromes

Basilar Artery Syndromes

Complete basilar syndrome results in bilateral long tract signs with variable cerebellar, cranial nerve, and other segmental abnormalities of the brainstem. Patients may be comatose (ischaemia of the high midbrain reticular activating system). Patients may be mute and quadriplegic but conscious due to interruption of motor pathways and sparing of the reticular activating system (“locked-in” syndrome).

Occlusion of branches may result in various combinations of symptoms and signs. Patients may have somnolence, memory defects, visual hallucinations, disorder of ocular movements, skew deviation of the eyes, confusional state and visual defects.

Occlusion of Superior Cerebellar Artery

Patients have ipsilateral cerebellar ataxia, nausea, vomiting, slurred speech, loss of pain and thermal sensation over the opposite side of the body (spinothalamic tract), partial deafness, static tremor of the ipsilateral upper extremity, an ipsilateral Horner’s syndrome, and palatal myoclonus.

Occlusion of Anterior Inferior Cerebellar Artery (AICA)

Patients have vertigo, nausea, vomiting, nystagmus, tinnitus, deafness, facial weakness, ipsilateral cerebellar ataxia, ipsilateral Horner’s syndrome, paresis of conjugate lateral gaze, contralateral loss of pain and temperature over arm, trunk and leg (lateral spinothalamic tract) with or without hemiplegia (when occlusion is close to the origin of the artery).

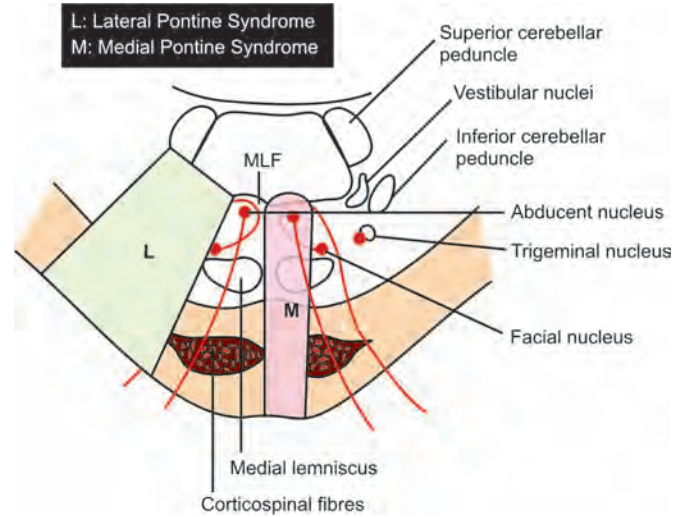

Fig. 8.86: Pontine syndromes

Pontine Syndromes

Superior pontine syndrome (paramedian branches of upper basilar artery) (Fig. 8.86).

A. Medial

Symptoms	Structures involved
Internuclear ophthalmoplegia	Medial longitudinal fasciculus
Myoclonic syndrome	Inferior olivary nucleus
Contralateral loss of position sense and vibration sense	Medial lemniscus

B. Lateral (Syndrome of Superior Cerebellar Artery)

Symptoms	Structures involved
Cerebellar ataxia	Superior surface of cerebellum, superior and middle cerebellar peduncles
Horizontal gaze palsy	Parapontine reticular formation (PPRF)
Horner’s syndrome	Descending sympathetic fibres
Dizziness, nausea, vomiting, horizontal nystagmus	Vestibular nucleus

Mid Pontine Syndromes

A. Medial

Symptoms	Structures involved
Contralateral loss of joint position sense, vibration sense	Medial lemniscus
Limb and gait ataxia	Pontine nuclei
Weakness of face, arm, leg	Corticospinal and corticobulbar tracts



Differentiating Various Types of Cerebro Vascular Disorders

Clinical Features	Embolism	Thrombosis	Haemorrhage
Age	Younger	Middle or old	Middle or old
Mode of onset	Acute	Insidious	Acute
Time of onset	Often during day	Often during sleep	Abruptly during waking hours
History of			
1. Convulsions	Present	–	Present
2. Hypertension	–	–	Present
3. Cardiac lesion	Present	–	
Recovery pattern	Rapid recovery	Gradual	Delayed or no recovery
Prognosis	Good	Fair	Bad

B. Lateral

Symptoms	Structures involved
Paralysis of muscles of mastication and impairment of sensation over face	Nucleus of 5th nerve
Contralateral loss of pain and temperature	Spinothalamic tract

Inferior Pontine Syndromes

A. Medial

Symptoms	Structures involved
Nystagmus	Vestibular nucleus
Diplopia on lateral gaze	VI nerve nucleus
Ipsilateral ataxia, conjugate gaze paresis	
Contralateral weakness of face, arm, and leg	Corticospinal and corticobulbar tracts
Contralateral tactile and proprioception loss	

B. Lateral (Anterior Inferior Cerebellar Artery Involvement)

Symptoms	Structures involved
Facial paralysis	VII nerve
Vertigo, nausea, vomiting, tinnitus, deafness	VIII nerve
Impaired sensation over face	Descending tract of V nerve
Impaired sensation over opposite side of body	Spinothalamic tract

Cerebellar peduncles will be affected in superior, middle and inferior pontine lesions of both medial and lateral side (Figs 8.87 and 8.88).

Medial lemniscus, corticobulbar tract of VI nerve, corticospinal tracts are affected at all levels in medial pontine syndrome giving rise to contralateral signs and symptoms.

Localisation of Site of Lesion

Site of lesion	Localising clinical features
Cortex	Aphasia Bladder involvement Cortical sensory loss Denial Epilepsy (focal fits) Flaccid mono or hemiplegia
Internal capsule (most common site)	Hemiplegia, hemianaesthesia hemianopia Spasticity marked
Thalamus	Fleeting hemiparesis or hemiplegia in the side opposite to the lesion. Impairment of superficial and loss of deep sensation on opposite side. Elevation of threshold to cutaneous tactile, thermal and painful stimuli, intolerable, spontaneous pains and hyperpathia
Midbrain	Upper level—Weber's syndrome (III nerve palsy + contralateral hemiplegia)—cerebral peduncle Lower level—Benedikt's syndrome (III nerve palsy + contralateral cerebellar or rubral tremor + contralateral hemiplegia)
Pons	Millard-Gubler syndrome (ipsilateral facial and gaze palsy + contralateral hemiplegia), Foville's syndrome (Ipsilateral VI, VII nerves + contralateral hemiplegia)
Medulla	Medial medullary syndrome Lateral medullary syndrome
Spinal cord (rare)	Same side hemiplegia; No cranial nerve lesion

Spinothalamic tract is involved at all levels of lateral pontine syndromes.

Ataxia is present in all lesions due to involvement of middle cerebellar peduncles. In superior pontine involvement, superior peduncle may also be involved.

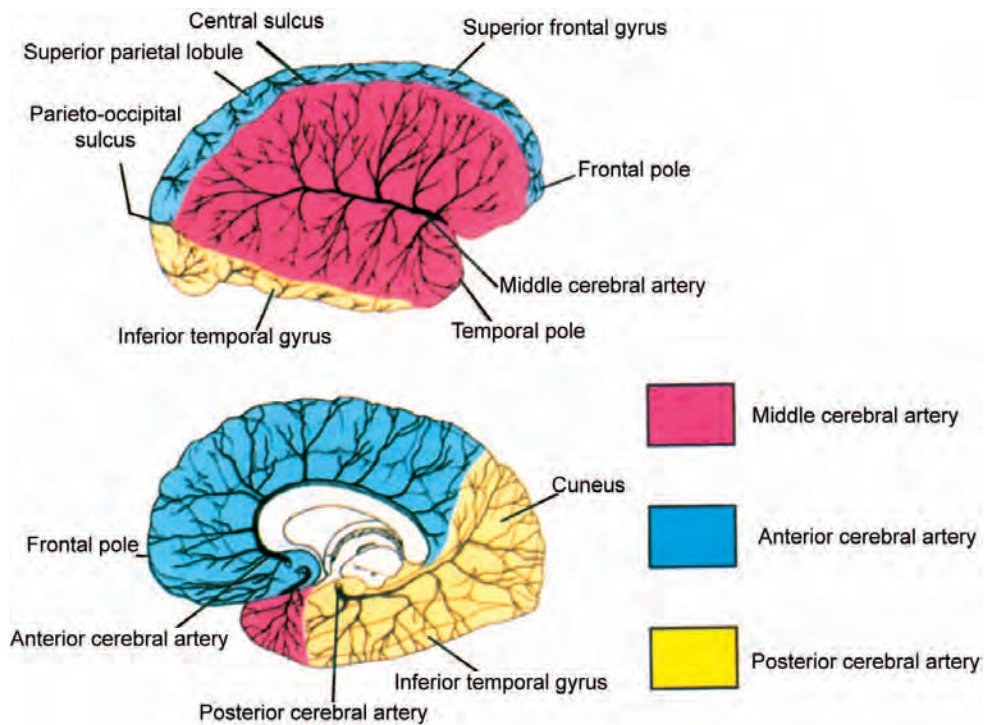

Fig. 8.87: Functional localisation of cerebral cortex

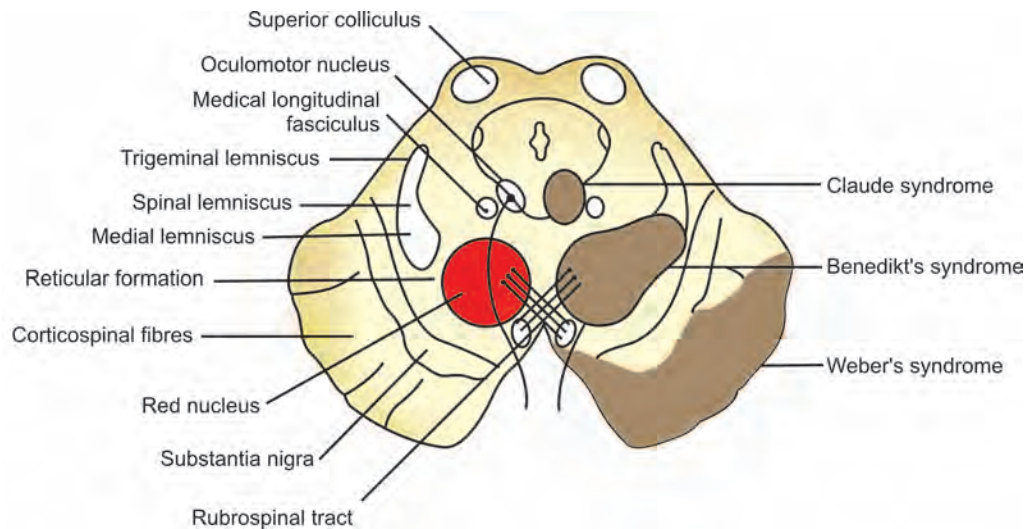

Fig. 8.88: Midbrain syndromes



Vestibular nucleus is involved in superior pontine (lateral) and inferior pontine (medial and lateral) syndromes.

V, VII and VIIIth nerves are affected in the inferior lateral pontine syndromes.

VI nerve is affected in medial inferior pontine syndrome.

V nerve nucleus (motor and sensory) is affected in lateral mid pontine syndrome.

Young Stroke

Young stroke refers to stroke occurring in persons below 40 years of age.



Causes

I. Infants and Children

Congenital heart disease
Arteriovenous malformation
Thrombosis of veins.

II. Children and Young Adults

a. Cardiovascular

Rheumatic heart disease
Infective endocarditis
Embolism
Prosthetic valve
Mitral valve prolapse
Left atrial myxoma.

b. Specific arteritis

TB
Syphilis
Nonspecific arteritis
Aorto-arteritis
Moya moya disease
Takayasu's arteritis
Trauma
Drugs.

c. Collagen vascular disorders

Systemic lupus erythematosus
Antiphospholipid syndrome
Spontaneous dissection of carotid.

d. Inborn errors of metabolism

Homocystinuria
Fabry's angiokeratosis.

e. Haematological

Sickle cell disease
Idiopathic thrombocytopenic purpura.

f. Thrombophilia

Congenital

1. Activated protein C resistance syndrome (Factor V Leiden)

2. Protein C, S deficiency
3. Antithrombin III deficiency
4. Hyperhomocystenaemia (MTHFR mutation)
5. Tissue plasminogen activator deficiency
6. Hyperfibrinogenaemia
7. Factor XII deficiency
8. High concentration of factor VIII
9. Heparin cofactor II deficiency
10. Prothrombin gene mutation.

Acquired

1. Increasing age
2. Cancer
3. Pregnancy
4. OCP and HRT
5. Antiphospholipid syndrome
6. Nephrotic syndrome
7. Myeloproliferative disorders
8. Paroxysmal nocturnal haemoglobinuria
9. Hyperhomocystenaemia
10. High level factor VIII
11. Heparin induced thrombocytopenia
12. Hyperviscosity.



Investigations (Figs 8.89 to 8.92)

I. Baseline investigations

1. Full blood count, ESR
2. Serological tests for syphilis
3. Blood glucose and urea
4. Serum electrolytes and proteins
5. X-ray chest
6. ECG and ECHO
7. Carotid Doppler.



Fig. 8.89: Carotid angiogram—MCA occlusion

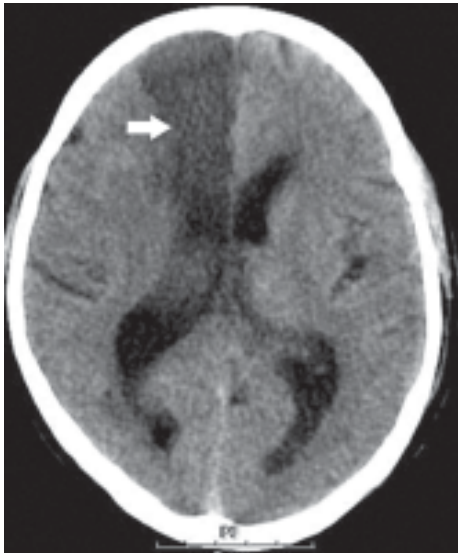

Fig. 8.90: Infarct in anterior cerebral artery territory

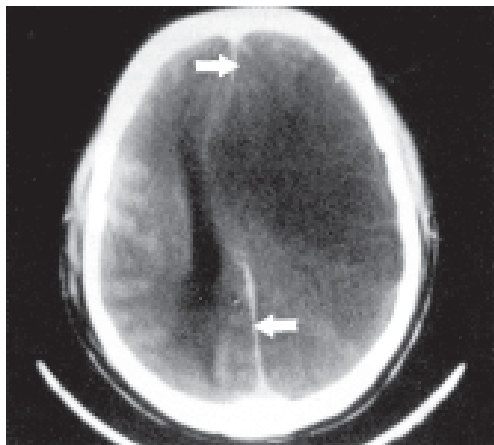

Fig. 8.91: CT brain—large right cerebral infarct with hyperdense SAH in the interhemispheric fissure

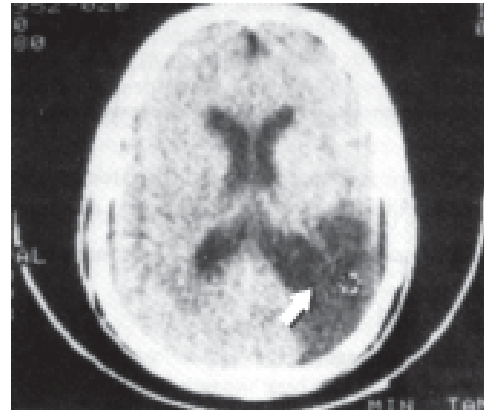

Fig. 8.92: CT brain—watershed zone infarct

2. To decide the line of management (to decide on therapy with anticoagulants or antiplatelet drugs).
3. To identify the presence of underlying tumour, haematoma or vascular malformation which can simulate stroke.
4. Head CT scan is diagnostic of SAH in 90% of cases in the first 24 hours.

IV. *MRI*: It is the preferred modality of investigation in cases of posterior fossa infarcts and for patients having TIA.

MR angiography is a useful non-invasive test to evaluate large arteries and veins.

V. *Angiography*: It is not usually indicated but indicated only to rule out specific causes such as arterial dissection.

- Definitive study for vascular malformations
- Essential test prior to endarterectomy
- Pre-surgical evaluation of saccular aneurysms

VI. *Cardiac Evaluation* (for sources of thromboembolism).

II. Special investigations (especially young patients)

1. Antinuclear antibodies (ANA) for SLE, rheumatoid arthritis
2. Antibodies to double stranded DNA (SLE)
3. Anticardiolipin antibodies (SLE)
4. Lupus anticoagulant (antiphospholipid antibodies)—SLE
5. Serum cholesterol (familial hyperlipidaemia).

III. CT Scan—Indications

CT scan is mandatory for proper initial evaluation in all cases of stroke to categorise them into either ischaemic or haemorrhagic origin.

1. To confirm diagnosis (haemorrhage can be detected immediately whereas it may take 48 hours for infarcts to be detected).

CT Findings in Cerebral Infarction

Stage of infarct	CT findings
Hyperacute (< 12 hours)	Normal (50 to 60%), hyperdense artery (25 to 50%), obscuration of lentiform nuclei
Acute (12 to 24 hours)	Low density basal ganglia, loss of grey-white matter interface (insular ribbon sign), sulcal effacement
1 to 7 days	Mass effect, wedge-shaped low density area involving white and grey matter, haemorrhagic transformation, gyral enhancement
1 to 8 weeks	Contrast enhancement persists, mass effect resolves
Months to years	Encephalomalacic change, volume loss, rarely calcification



Management

I. Specific Management

1. Medical Management

a. *Blood pressure*: There is likely to be a stress induced hypertensive state in acute stroke. So, all cases may not need antihypertensive drugs. However, oral antihypertensive drugs are indicated in persistent or accelerated hypertension or when there are signs of end organ damage. Sudden lowering of blood pressure can exacerbate infarction.

A patient's blood pressure at presentation should not be lowered unless it is more than 185/110 mmHg, as the ischaemic penumbral tissue will infarct with even minor drop in systemic blood pressure, because cerebral autoregulation in this zone is impaired.

b. Anticoagulants—Indications

1. When there is a definite source of emboli (AF, dissection of carotid artery)
2. Stroke evolving over hours or days especially in posterior circulation stroke
3. Repeated TIAs (embolic)
4. Cortical venous thrombosis

c. Treatment of cerebral oedema

Cerebral oedema represents an excess accumulation of water within the brain tissues.

MRI Findings in Cerebral Infarction

Stage of Infarction	MRI findings
Immediate	Intravascular contrast enhancement; Alteration of perfusion/diffusion coefficient
< 12 hours	Anatomic changes of T ₁ images (gyral thickening, sulcal effacement loss of grey-white interface)
12 to 24 hours	Hyperintensity, mass effect, leptomeningeal enhancement
1 to 3 days	Obvious abnormality in T ₁ and T ₂ images (early parenchymal contrast enhancement, haemorrhagic transformation)
4 to 7 days	Parenchymal enhancement, Haemorrhage (in 25%)
1 to 8 weeks	Mass effect resolves, decreased signal on T ₂ images, enhancement persists, haemorrhage signal evolves
Months to years	Encephalomalacic changes, volume loss in affected area, haemosiderin staining (in significant haemorrhage)

Pathophysiology

- i. Vasogenic oedema refers to the influx of fluids and solutes into the brain, due to incompetent blood-brain barrier.
- ii. Cytotoxic oedema refers to cellular swelling in response to exogenous toxins, brain ischaemia and trauma.

Management

1. Head end elevation to 30°.
2. Osmotherapy by oral glycerol (30 ml TDS), and mannitol (25-100 gm 4th hourly). Mannitol is contraindicated in cardiac failure and renal failure.
3. Pressor therapy to maintain adequate mean arterial pressure to ensure cerebral perfusion pressure of more than 70 mmHg.
4. Hyperventilation to reduce PaCO₂ to 30-35 mmHg.
5. Frusemide can be used as an adjuvant with Mannitol.
6. Avoid glucocorticoids in trauma, ischaemia and haemorrhagic stroke.

In refractory cases

7. High dose barbiturate therapy.
8. Aggressive hyperventilation.
9. Hemicraniectomy.
10. Hypothermia.

Relief of the increased intracranial tension in CVA is needed only in haemorrhage or massive infarction, causing midline shift.

d. Thrombolysis

Indications

- i. Clinical diagnosis of stroke.
- ii. Onset of symptom to time of drug administration < 3 hr.
- iii. CT scan showing no haemorrhage or significant oedema.
- iv. Age > 18 years.
- v. Consent by patient or surrogate.

Contraindications

- i. Sustained BP > 185/110.
- ii. Platelets < 1 lakh, PCV < 25%, Glucose < 50 or > 400 mg%.
- iii. Use of heparin within 48 hour or prolonged PTT or INR.
- iv. Rapidly improving symptoms.
- v. Prior stroke or head injury in 3 months.
- vi. Major surgery in preceding 14 days.
- vii. Minor stroke symptoms.
- viii. GI bleeding in preceding 21 days.
- ix. Recent MI.
- x. Coma or stupor.

Dose of rtPA (recombinant tissue plasminogen activator): 0.9 mg/kg IV (max 90 mg). 10% of the total dose bolus, followed by remainder of total dose over 1 hour.

e. *Antiplatelet drugs*

These are used in the primary as well as secondary prevention of stroke.

- i. *Aspirin:* It is given in a dose of about 150 mg/day so as to suppress the production of TXA₂.
- ii. *Ticlopidine:* This is recommended at present in a dose of 250 mg PO bid for patients who cannot tolerate aspirin and for those who develop recurrent stroke while on aspirin. The side effects are skin rash, diarrhoea, reversible neutropenia, and therefore patients need more careful monitoring.
- iii. *Glycoprotein IIb IIIa inhibitors:*
Abciximab 0.25 mg/kg IV bolus
Clopidogrel 75 mg PO QID.

2. Surgical Management

Carotid endarterectomy is useful in patients with TIA with haemodynamically significant (> 70%) carotid stenosis.

II. General Management

- a. Attend to bladder, bowel, back, base of lungs and eyes
- b. Patients should be ideally placed in the semiprone position if unconscious to prevent aspiration
- c. Proper nursing, feeding (if needed, through Ryle's tube)
- d. Intake and output chart should be maintained
- e. Physiotherapy
 - i. It is started immediately to prevent joint contractures and to promote recovery of strength and coordination
 - ii. Physiotherapy of the chest is done to prevent lung infection.

Subclavian Steal Syndrome

This occurs due to stenosis or occlusion of the subclavian artery proximal to the origin of the vertebral artery. The increased metabolic demand of the left or right arm musculature during exercise is met by retrograde blood flow down the vertebral artery and this results in symptoms of brainstem ischaemia.



Clinical Features

Unequal pulse and BP between two upper limbs and bruit over supraclavicular fossa over the affected subclavian artery.

Lacunar Infarction

Lacunar infarcts are small deep infarcts (usually 3 mm-2 cm in diameter) secondary to disease of the small perforating branches within the brain substance.

The major risk factor is age and hypertension, which produces microatheroma, lipohyalinosis and dissection of the tiny penetrating vessel.



Clinical Features

1. *Pure Motor Stroke:* There is complete or incomplete weakness of one side of body involving the whole or two out of three body areas (face, upper limb, leg). Lesion is in the internal capsule or basis pontis.
Pure motor hemiparesis with motor aphasia may occur due to a lesion in genu and anterior limb of internal capsule and adjacent corona radiata (white matter) as a result of involvement of lenticulo striate artery.
Heubner's recurrent artery can also be involved resulting in faciobrachial monoplegia.
2. *Pure Sensory Stroke:* Lesion is in the ventrolateral thalamus.
3. *Sensory and Motor Stroke.*
4. *Ataxic Hemiparesis:* This is a combination of hemiparesis and ipsilateral cerebellar ataxia often marked with dysarthria, clumsiness of hand and unsteadiness. Lesion is in the base of pons or genu of internal capsule.

Lacunar syndromes – Infarct Locations

- *Pure sensory stroke:* Thalamus (ventral posterior), Pons, deep white matter (cerebral cortex)
- *Pure motor stroke:* Posterior limb of internal capsule, basis pontis, cerebral peduncle, medullary pyramid
- *Ataxic hemiparesis:* Upper pons, posterior limb of internal capsule, thalamus, middle and lower pons
- *Dysarthria-clumsy hand syndrome:* Basis pontis, genu of the internal capsule. Corona radiate, cortical lesion
- *Sensorimotor stroke:* Thalamocapsular lacunes

Diagnosis

It can be diagnosed by CT (for supratentorial lesions) or MRI for both (supra and infratentorial lesions).



Treatment

1. Control of hypertension should be done only after the progression of the disease ceases, i.e. when the patient stabilizes. Immediate reduction in BP



- worsens the condition and hence gradual reduction of BP is advised
- Aspirin in a dose of 60 to 150 mg per day
 - Physiotherapy
 - Use of heparin is controversial
 - Dipyridamole 200 mg bid.

Cortical Venous Thrombosis (Dural Sinus Thrombosis) (Figs 8.93 and 8.94)

Cortical venous thrombosis (CVT) is a less common cause of cerebral infarction than arterial disease.

Patient usually presents with headache, drowsiness, seizures and a rapidly evolving focal neurological deficit.



Causes

Local

- Head injury (with or without fracture)
- Intracranial surgery
- Local sepsis (sinuses, ear, scalp, mastoids and nasopharynx)
- Bacterial meningitis
- Tumour invasion of dural sinuses
- Dural or cerebral AVM.

Systemic

- Pregnancy, puerperium, oral contraceptive pills
- Septicaemia
- Dehydration
- Haematological disorders (sickle cell anaemia and polycythaemia)
- Antifibrinolytic drugs
- Nephrotic syndrome.



Clinical Features

General

- Seizures with focal neurological deficit with or without altered sensorium
- Raised intracranial pressure with headache and vomiting
- Features simulating intracranial space occupying lesion.

Sites of Involvement

- Cavernous sinus*: Proptosis, ptosis, headache, external and internal ophthalmoplegia, papilloedema, reduced sensation in ophthalmic division of trigeminal nerve.

- Superior sagittal sinus*: Headache, papilloedema, seizures. May involve veins of both hemispheres causing advancing motor (paraplegia) and sensory (cortical sensory) deficits.
- Transverse sinus*: Hemiparesis, seizures, papilloedema, involvement of cranial nerves IX, X and XI.



Investigations

- Blood culture
- CSF examination (increased pressure, protein may be raised, leucocytosis)
- CT scan can show the presence of clot in the affected sinuses/adjacent area of infarction.

a. Direct signs

- Cord sign*: In plain CT scan, hyperdensity of the straight sinus and cortical vein which is due to fresh blood clot within the vein or sinus.
- Empty delta sign*: This is seen in contrast CT, contrast enhancement of the walls of the superior sagittal sinus with hypodense area within it (Fig. 8.93).

b. Indirect signs

Diffuse brain oedema: It is characterised by hypodensity of the white matter; compression of lateral ventricle and effacement of cortical sulci. It may be unilateral or bilateral.

CT may be normal at first and then at one week delta sign develops.

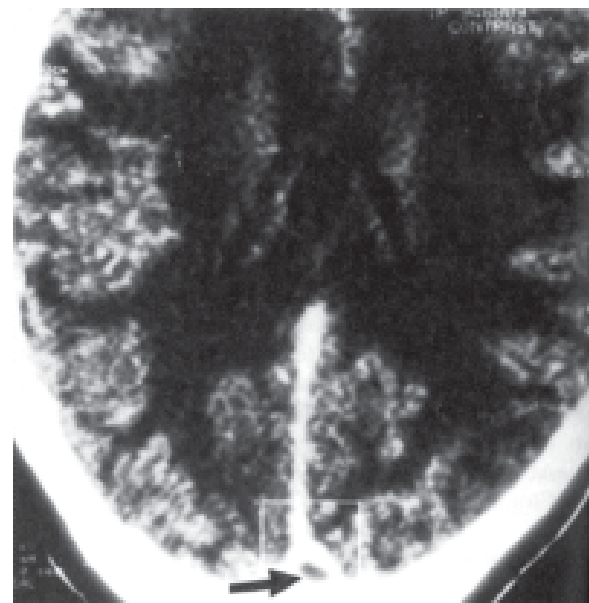
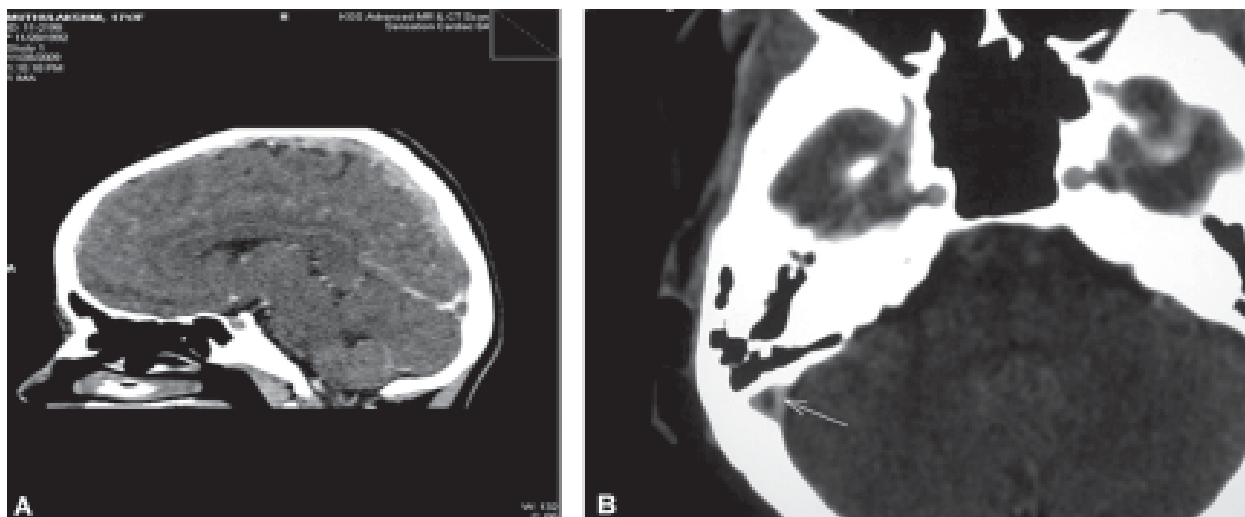

Fig. 8.93: CT brain (contrast)—empty delta sign in cortical venous thrombosis



Figs 8.94A and B: Dural sinus thrombosis (A) right transverse sinus thrombosis (B) right sigmoid sinus thrombosis (Dense triangle sign)

4. Carotid angiography (sinus with thrombus fails to fill).

Treatment

- i. Treat infection with antibiotics.
- ii. Anticoagulants are indicated.
- iii. Adequate hydration.
- iv. Antioedema measures if needed.

Prognosis

Recovery is good; prognosis is better than arterial occlusion. Prognosis depends on extent of thrombus. Cerebral damage may be permanent.

Intracerebral Haemorrhage (ICH)

The common risk factors for intracerebral haemorrhage are:

1. Hypertension (80%)
2. Arteriovenous malformation (2%)
3. Bleeding diathesis (2%)
4. Amyloid angiopathy
5. Drug abuse.

Common anatomical sites affected by ICH are:

1. Putamen (35%)
2. Lobar (30%)
3. Thalamus (20%)
4. Caudate nucleus (5%)
5. Pons (5%)
6. Cerebellar (3%)
7. Subthalamus (2%).



Clinical Features

General

Males below 40 years of age are predominantly affected. It occurs mostly during day when the patient is active. However, it may occur at any time.

Patient usually presents with sudden loss of consciousness or altered sensorium. There are signs and symptoms of raised intracranial tension (headache, vomiting, seizures and papilloedema) and neck stiffness (if there is extension of blood into the ventricles and sub-arachnoid space).

Clinical Features of ICH Depending on Site of Haemorrhage

- a. *Putaminal Haemorrhage*
 1. Hemiparesis or hemiplegia and to a lesser degree, hemisensory deficit, opposite to the side of putaminal haemorrhage.
 2. Transient global aphasia with dominant hemispheric lesion.
 3. Apractagnosia or unilateral neglect with nondominant hemispheric lesion.
 4. Homonymous hemianopia.
 5. Contralateral gaze palsy; patient looks to the side of the haemorrhage and away from the hemiplegia.
- b. *Thalamic Haemorrhage*
 1. Hemisensory deficit and to a lesser degree, hemiparesis, opposite to the side of thalamic haemorrhage.



2. Nonfluent aphasia with intact repetition and variably impaired comprehension with lesions of the dominant thalamus.
 3. Convergence-retraction nystagmoid movements, impairment of vertical gaze and pupillary light-convergence dissociation.
 4. Downward and inward deviation of the eyes (sometimes skew deviation of the eyes may be seen).
 5. Conjugate gaze palsy to the side of lesion; patient looks to the side of the hemisensory loss and away from the side of haemorrhage.
- c. *Cerebellar Haemorrhage*
1. Variable degree of alertness.
 2. Small reactive pupils.
 3. Skew deviation of the eyes.
 4. Ipsilateral gaze palsy.
 5. Occasionally ocular bobbing may be seen.
 6. Ipsilateral facial weakness.
 7. Ipsilateral absence of corneal reflex.
 8. Slurred speech.
 9. Ataxic gait with truncal ataxia (truncal ataxia more common than limb ataxia).
 10. Bilateral hyper-reflexia and Babinski sign positive.



Investigations

1. *CT scan brain:* This demonstrates the site and size of the haemorrhage, presence of mass effect and midline shift if present or presence of hydrocephalus (Figs 8.95 to 8.100).
2. *Blood investigation:* This is done to rule out bleeding diathesis.

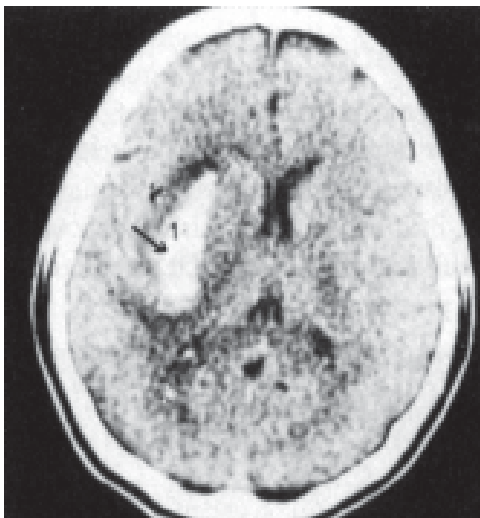

Fig. 8.95: CT brain—intracerebral bleed

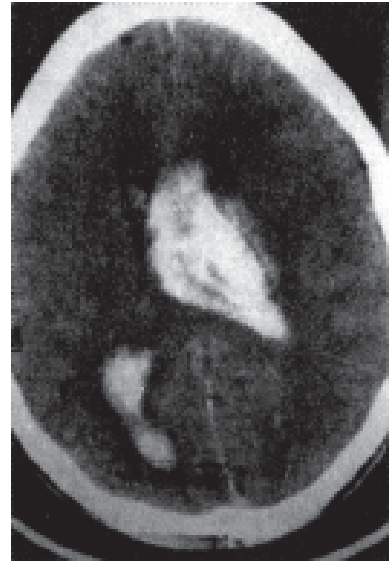

Fig. 8.96: CT brain—intracerebral bleed with intraventricular extension

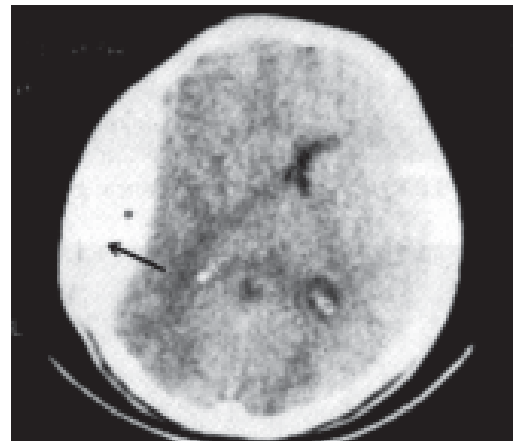

Fig. 8.97: CT brain—acute subdural haematoma (hyperdense)

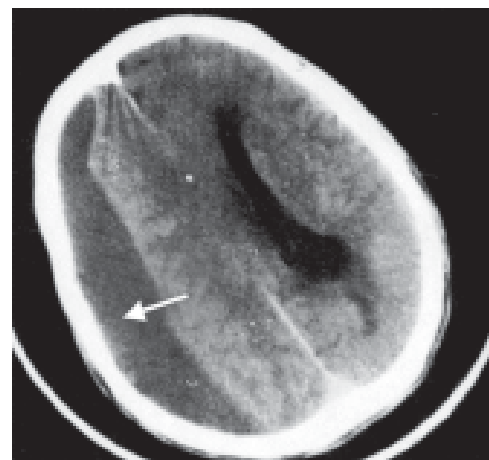

Fig. 8.98: CT brain—chronic subdural haematoma (hypodense)

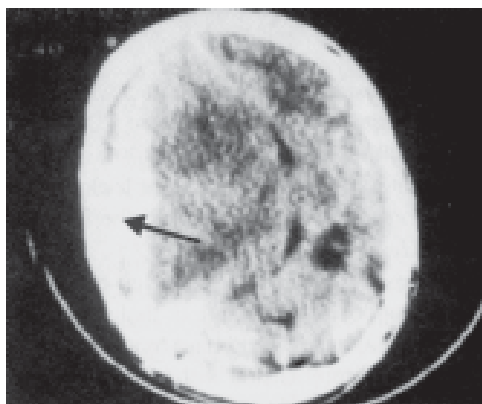

Fig. 8.99: CT brain—extradural haemorrhage

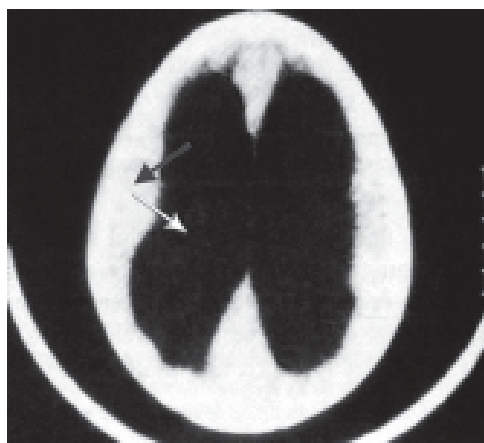

Fig. 8.100: CT brain—hydrocephalus (dilated ventricles)

3. *MRI appearance of intracranial haematoma:*
As given in Table below.

However, CT is the preferred modality of investigation in intracerebral haemorrhage. MRI is normal in the first 24 hours but it becomes more specific than CT in determining the age of haemorrhage.

4. *Angiogram:* This is done to detect the presence of vascular anomaly as the source of ICH.



Management

1. Maintenance of fluid and electrolyte balance (Ryle's tube feeding in unconscious patients and bladder catheterisation).
2. Regular change of posture and care of skin to avoid bed sores.
3. Monitoring of blood pressure (diastolic pressure not to be lowered below 110 mmHg in the first 48 hours).
4. Antioedema measures with mannitol 0.5–1.0 gm/kg as rapid IV infusion or with 10% glycerol 500 ml IV infused over 4 hours daily for 6 days.
5. *Surgery:* It is indicated in cerebellar haemorrhage, whereby the haematoma can be surgically removed. This is not recommended in haemorrhage at other sites, as this may result in permanent neurological deficit.

Poor Prognostic Factors in ICH

1. Putaminal haemorrhage larger than 6 cm.
2. Thalamic or cerebellar haemorrhage larger than 3 cm.
3. Lobar or intraventricular haemorrhage.

In general, immediate prognosis in the acute phase is grave and in minimal haemorrhage, once the patient tides over the initial phase, prognosis is good.

Subarachnoid Haemorrhage (SAH)

Subarachnoid haemorrhage accounts for 8% of all strokes.



Causes of SAH

1. Ruptured berry aneurysm (> 50%).
2. Arteriovenous malformation (AVM).
3. Extension of ICH.
4. Haemorrhage into cerebral infarct.
5. Haemorrhage into cerebral tumour.
6. Rupture of an atheromatous vessel.

MRI Appearance of Intracranial Haematoma

Stage of haematoma	Blood product	T ₁ -Images	T ₂ -Images
1. Hyperacute (few min to hour)	Oxyhaemoglobin	Isointense	Hyperintense
2. Acute (few hour onwards)	Deoxyhaemoglobin	Moderately hypointense	Profoundly hypointense
3. Early subacute (few weeks)	Intracellular methaemoglobin	Hyperintense	Hyperintense
4. Late subacute (months)	Extracellular methaemoglobin	Hyperintense	Hyperintense
5. (a) Chronic early	Methaemoglobin surrounded by haemosiderin	Hyperintense surrounded by hypointense rim	Blooming of hyperintense rim
(b) Chronic late	Haemosiderin	Hypointense	Further hypointense (blooming)



7. Rupture of mycotic aneurysm.
8. Bleeding diathesis.

Common Sites of Aneurysm

1. *Carotid system*
 - a. Anterior communicating artery.
 - b. At the bifurcation of middle cerebral artery from internal carotid artery.
 - c. Origin of the posterior communicating artery from internal carotid artery.
2. *Vertebrobasilar system*
 - a. At the apex of the basilar artery.
 - b. At the origin of posterior inferior cerebellar and superior cerebellar arteries from basilar artery.

Aetiopathogenesis of Aneurysm Formation

1. Congenital defect in the media of the blood vessels at the point of bifurcation.
2. Hemodynamic stress at the point of bifurcation of vessel.

Conditions Associated with Aneurysm

1. Coarctation of the aorta
2. Polycystic kidneys
3. Moya moya
4. Marfan's syndrome
5. Hereditary haemorrhagic telangiectasia
6. Pseudoxanthoma elasticum
7. Ehlers-Danlos syndrome.



Clinical Features of SAH

- a. *Before rupture of aneurysm:* The II, III, IV, VI and ophthalmic division of the V cranial nerves may be involved due to compression by the aneurysm of internal carotid artery within the cavernous sinus. Isolated III cranial nerve palsy may be seen with aneurysm of the posterior communicating artery.
- b. *After rupture of aneurysm:* SAH due to rupture of aneurysm often occurs during exertion, when there is a rise in blood pressure, as occurs during straining or during sexual intercourse.

Patients present with headache, vomiting, altered sensorium, meningeal irritation, seizures and rarely with focal neurological deficit. Focal neurological deficit, if present, may help to localize the site of aneurysm (e.g. aneurysm of anterior cerebral artery results in hemiplegia with lower limb involvement more than the upper limb involvement).

Neck stiffness takes six hours to develop but fundus shows retinal and sub-hyaloid haemorrhage.



Complications of SAH

1. *Rebleed:* This may occur maximally within 24 hours. In 90% of patients rebleed within 6 months. Rebleed is characterised by sudden deterioration of symptoms and signs, with onset of headache, meningeal irritation and loss of consciousness.
2. *Vasospasm:* Vasospasm of intracranial cerebral vessels leads to cerebral ischaemia. It is insidious in onset and multifocal. Twenty per cent of the patients experience this complication within the first 2 weeks of bleed. This is characterised by fall in the level of consciousness and appearance of focal neurological deficit.
3. *Hydrocephalus:* This occurs due to blockage of normal CSF flow by Pacchionian granulation tissue. It is characterised by increase in severity of headache and progressive deterioration of sensorium.
4. *Hyponatraemia.*



Causes of Thunderclap Headache

1. Sub-arachnoid haemorrhage (25%)
2. Meningitis
3. Migraine
4. Intra-cerebral bleeds
5. Cerebral venous thrombosis
6. Dissection of carotid or vertebral artery.



Investigations

1. *CT Scan Brain:* This may show
 - a. Blood in the subarachnoid space and associated parenchymal haematoma. Hyperdense areas are seen in anterior interhemispheric fissure, both sylvian fissures, in the ventricular system and basal cisterns (see Figs 8.98 and 8.99).
 - b. Site of bleed.
 - c. Demonstration of presence of aneurysm (by contrast CT).
 - d. Presence of associated hydrocephalus (see Fig. 8.100).
2. *Lumbar Puncture:* This is done when CT is negative, and in presence of SAH, the following may be observed
 - a. Homogenously blood stained CSF (when LP is done early).
 - b. Xanthochromia (when LP is done later).
 - c. Rise in CSF pressure.

However, if there is strong clinical suspicion of SAH even after a normal CT, an urgent lumbar puncture has to be done 12 hours after the onset of



headache to get blood stained CSF. Xanthochromia of CSF takes 6-12 hours to develop.

3. *Angiography*: This helps in locating the site of aneurysm and for planning surgery.

Do angiography as early as possible after ictus and selective 4 vessel angiography must be done. Multiple oblique views may show aneurysmal neck. Cross compression views delineate anterior communicating and posterior communicating arteries and cross-circulation. Subtraction images are preferred for posterior fossa aneurysms and Towne's view for carotid angiogram.

4. *MRI Angiography*: This is indicated in:
 - a. Angiography negative subarachnoid haemorrhage.
 - b. Complementary to angiography or DSA.
 - c. Renal failure or when contrast injection is contra-indicated.
 - d. Screening in patients with polycystic disease, coarctation, fibromuscular dysplasia, and family history of aneurysms.



Treatment of SAH

1. In the acute phase, the patient is treated for signs and symptoms of raised intracranial tension.
2. General care of the patient (maintenance of fluid and electrolyte balance, care of the skin and adequate airway and ventilation).
3. Control of hypertension (diastolic BP to be maintained at about 110 mmHg).
4. SAH is usually associated with vasospasm of intracranial vessels which can lead to cerebral ischaemia and so must be managed as follows:
 - i. IV isoproterenol and nitroglycerine.
 - ii. Volume expansion.
 - iii. Slow calcium channel inhibitors have been proposed. Nimodipine 30–60 mg orally every 4 hours may be given for 3 weeks.
5. If SAH is found to be due to arterial aneurysm, then surgical clipping of the aneurysm is done after patient has stabilised, to prevent rebleed. Aneurysms larger than 7 mm size, when detected before development of SAH, warrant prophylactic surgical obliteration.

Association

Intracranial saccular aneurysms may be associated with:

1. Polycystic kidneys
2. Cervical artery dissection
3. Fibromuscular dysplasia of arteries
4. Coarctation of the aorta

5. Marfan's syndrome
6. Ehlers-Danlos syndrome
7. Pseudoxanthoma elasticum
8. Hereditary haemorrhagic telangiectasia
9. Moya moya disease
10. Klinefelter's syndrome.

SAH Due to Other Causes

1. Bleeding diathesis
2. Rupture of small penetrating arterioles or venules
3. Bleeding from arteriovenous malformation.

Arteriovenous Malformation (AVM)

AVM is the next common cause of non-traumatic SAH.

Types of AVM

1. Venous angioma
2. Telangiectasia
3. Varix
4. AV angioma
5. Cavernous angioma.



Clinical Features

Patients may complain of headache, tinnitus or vascular noises in the head, which may give a clue to the presence of AVM. This may be confirmed by auscultating a bruit over the cranium.

If patient develops SAH, then he/she presents with increasing severity of headache, altered sensorium and fits.



Investigations

1. CT scan (plain and contrast)
2. Cerebral arteriogram.
3. MR angiogram.



Treatment

1. Surgical excision of AVM
2. Stereotactic radiotherapy
3. Therapeutic embolisation
4. Anticonvulsants in presence of seizures
5. Treatment of complication (SAH).

Brain Death

Brain death occurs from irreversible brain injury that is sufficient to eliminate all cortical and brainstem function permanently. Because the vital centers in the brainstem



sustain cardiovascular and respiratory functions, brain death is incompatible with survival despite mechanical ventilation and cardiovascular and nutritional supportive measures. The first and most critical step in establishing the diagnosis of brain death is to establish an irreversible, untreatable etiology for the brain injury. Examples include global ischaemia due to cardiac arrest, asphyxia as in near drowning, intracranial bleed and severe head injury.

Before confirming brain death, exclude reversible conditions like hypothermia, drug intoxication, metabolic disorders like hypoglycaemia, acidosis, and electrolyte imbalance.

Brain death is a clinical diagnosis.

Essential Neurological Signs

1. Deep coma with absent respiration
2. No response to visual, auditory, or painful stimulation
3. Unreactive pupils
4. No eye movements for oculocephalic or oculo-vestibular manoeuvres
5. Absent corneal, gag and cough reflexes
6. No response to noxious external stimulation—Spinal reflexes do not preclude the diagnosis of brain death
7. No respiratory effort.

Ancillary Diagnostic Supportive Tests

1. EEG—Electrocerebrosilence—A flat isoelectric trace
2. Radionuclide or conventional four vessel angiography — Absence of cerebral blood flow

3. Evoked potentials—Somatosensory or brainstem evoked potentials demonstrate absence of cortical and subcortical responses with intact peripheral responses.

The patient is declared dead after second evaluation at an interval of 24 hours to confirm the persistent absence of cortical and brainstem function.

Headache

Headache is one of the most common and frequent complaints. It is usually a benign symptom and only occasionally it is a manifestation of a serious illness, such as brain tumour or giant cell arteritis.

Most headaches are dull, deeply located and of aching character. A throbbing headache with tight muscles about the head, neck and shoulder girdle suggest activation of intra and extracranial arteries and skeletal muscle surrounding the head and neck by a generic head pain generating mechanism.

Brief, sharp cephalic pain which is multifocal is more often benign.

Pain intensity seldom has diagnostic value.

Headaches may originate from either of the two mechanisms:

1. Pain commonly results from activation of peripheral nociceptors in the presence of normally functioning nervous system.
2. Injury or activation of the peripheral or central nervous system.

Common Types of Headache

Type	Site	Age and sex	Clinical features
Migraine	Frontotemporal, uni- or bilateral	All ages; female > male in adults; equal incidence in children	Onset after awakening; quelled by sleep; provoking factors—menses, odours, foods; stops after 2nd trimester of pregnancy; Less frequent and less severe with aging. Duration—6 hours to 2 days
Cluster headache	Orbital or temporal	All ages above 10; mainly in men; provoked by alcohol	Periodic attacks of 1 to 2 episodes per day; often nocturnal; duration—45 minutes; associated with red eye and stuffy nose; daily attacks for 6 weeks with annual recurrence
Tension headache	Generalised	Young adults, especially females	Tight band like discomfort; occurs in cycles of several years
Brain tumour	Variable	All ages; both sexes	Early morning headache interrupts sleep, exacerbated by orthostatic changes, associated with nausea and vomiting
Giant cell arteritis	Lateralised, temporal or occipital	Over 55 years; either sex	Scalp tenderness with superimposed jabbing and jolting pain lasting for weeks to months
Lumbar puncture headache	Bifrontal and/or bioccipital	Over 10 years; either sex	Orthostatic; present during sitting or standing and disappears during prone or supine positions. Persists for 3–4 days

Pain Sensitive Structures

Scalp, aponeurosis, middle meningeal artery, dural sinuses, falx cerebri, and the proximal segments of large pial arteries.

Pain Insensitive Structures

Most of brain parenchyma
Ventricular endyma
Choroid plexus
Pial veins.

There is a midbrain locus for generation of headache.

Mechanisms of Production of Headache

Headache can occur as a result of

1. Distention, traction or dilatation of intracranial or extracranial arteries.
2. Traction or displacement of large intracranial veins or their dural envelope.
3. Compression, traction or inflammation of cranial and spinal nerves.
4. Spasm, inflammation and trauma to cranial and cervical muscles.
5. Meningeal irritation and raised ICT.
6. Perturbation of intracerebral serotonergic projections (especially during a febrile illness, SLE, cerebral ischaemia or when pressure is reduced in benign ICT).

Intracranial masses cause headache by deforming, displacing or by exerting traction on vessels, dural structures or cranial nerves at the base of the brain. This happens long before ICT develops.

Evaluation of headache is done by careful history taking, physical examination and performing ancillary tests.

1. Headache exacerbated by red wine, exertion, odours, hunger, lack of sleep, weather change and menses is often benign. Periodicity is a characteristic feature of sinus headache.
2. Cessation of headache during pregnancy, especially in 2nd or 3rd trimester is pathognomonic of migraine.
3. History of amenorrhoea or galactorrhoea suggests polycystic ovary syndrome or a prolactin secreting pituitary adenoma as the cause of headache.
4. History of known malignancy suggests either cerebral metastases or carcinomatous meningitis.
5. In meningitis and systemic infection, there is accentuation of pain with eye movement.
6. Headache appearing abruptly after bending, lifting, or coughing suggest a posterior fossa mass or the Arnold-Chiari malformation.

7. Orthostatic headache suggests subdural haematoma or benign intracranial hypertension or a lumbar puncture done a few hours back.
8. Facial pain suggest trigeminal or glossopharyngeal neuralgia. There is paroxysmal, fleeting, electric shocklike episodes of facial pain often triggered by touch, swallowing, shaving, hot, cold, or sweet food.
9. Headache due to ICT is more in early morning; causes sleep disturbance; associated with projectile vomiting with or without focal neurological deficit.
10. Sentinel headache—Patients with SAH may earlier have experienced a sentinel headache perhaps due to a small warning leak from the offending aneurysm (6%).

Headache Caused by Systemic Illness

The following diseases characteristically present with headache:

1. Infectious mononucleosis
2. Systemic lupus erythematosus
3. Chronic respiratory failure (hypercapnia)
4. Hashimoto's thyroiditis
5. Drugs (glucocorticoid withdrawal, oral contraceptives, ovulation promoting drugs)
6. Inflammatory bowel disease
7. HIV associated illness
8. Malignant hypertension, pheochromocytoma (diastolic pressure of at least 120 mmHg are required for hypertension to cause headache).

Interpretation of Physical Findings and Possible Aetiology

<i>Physical finding</i>	<i>Possible aetiology</i>
Optic atrophy, papilloedema	SOL (mass lesion), hydrocephalus, BIH (benign intracranial hypertension)
Focal neurological deficit (hemiparesis, aphasia)	SOL (mass lesion)
Stiff neck	Subarachnoid haemorrhage, meningitis (with fever), cervical arthritis
Retinal haemorrhage	Ruptured aneurysm, malignant hypertension
Subhyaloid haemorrhage	Subarachnoid haemorrhage
Cranial bruit	Arteriovenous malformation (AVM)
Thickened, tender, temporal arteries (pulseless and cord like)	Temporal arteritis
Trigger point for pain over the face	Trigeminal neuralgia
Lid ptosis, IIIrd nerve palsy (dilated pupil)	Cerebral aneurysm (posterior communicating artery)



Investigations

Patients with headache of > 6 weeks duration and without abnormal clinical signs probably do not require investigations.

1. Complete blood count including ESR is required to exclude temporal arteritis over the age of 50 years.
2. X-ray
 - a. *Chest X-ray*: To rule out bronchogenic carcinoma and pulmonary tuberculosis
 - b. *X-ray cervical spine*: To rule out cervical spondylosis
 - c. Skull X-ray
 - i. Reveal evidence of ICT
 - ii. Midline shift (if the pineal gland is calcified)
 - iii. Calcification within the tumours (meningioma and craniopharyngioma)
3. CT scan brain to localise tumours
4. Lumbar puncture to rule out meningitis.



Treatment

A. TREAT POSSIBLE UNDERLYING CAUSES (sinusitis, trigeminal neuralgia, etc.)

B. MIGRAINE

Triggers (CHOCOLATE)

- Cheese
- Oral-contraceptives
- Caffeine
- Alcohol
- Anxiety
- Travel
- Exercise

In 50% of cases, no trigger is found.

General Measures

- a. Treat initiating factors (smoking, alcohol ingestion, lack of sleep, stress)
- b. Psychotherapy
- c. Avoid oral contraceptive pills
- d. Pharmacological treatment of acute migraine:
 1. NSAIDs –Acetaminophen, Aspirin, Caffeine
 2. 5 HT agonists

Oral Route:

Ergotamine 2 mg (maximum 3 mg/day)

Naratriptan 2.5 mg (repeat after 4 hours)

Sumatriptan 50-100 mg (maximum 200 mg/day)

Zolmitriptan 2.5 mg (maximum 10 mg/day)

Almotriptan 6.25-12.5 mg PO every 2 hours (maximum 25 mg/day)

Eletriptan 40 mg PO can be repeated in 2 hours (maximum 80 mg/day)

Frovatriptan 2.5 mg PO every 2 hours (maximum 7.5 mg/day)

Rizatriptan 5-10 mg PO every 2 hours (maximum 30 mg/day)

Triptans should not be used in patients with coronary artery disease, cerebrovascular disease, uncontrolled hypertension, hemiplegic – migraine, or vertebrobasilar migraine. Triptans should not be taken within 24 hours of other triptans, isometheptene, or ergot derivatives.

Ergotamine is a vasoconstrictive agent effective for aborting migraine headaches.

Rectal preparations (2 mg) are better absorbed than oral agents. Dihydroergotamine(DHE) is a potent venoconstrictor with minimal peripheral arterial constriction. It should be used with caution in patients with CAD, PVD and elderly.

Nasal Route:

Dihydro-ergotamine

Sumatriptan

Parenteral Route:

Dihydro-ergotamine 1 mg IV or IM or SC (maximum 3 mg/day)

Sumatriptan 6 mg SC (maximum 2 doses)

3. Dopamine antagonists (adjuvant)

Oral Route:

Metoclopropamide 5-10 mg/day

Prochlorperazine 1-2 mg/day

Parenteral Route:

Chlorpromazine 0.1 mg/kg IV

Metoclopropamide 10 mg IV

Prochlorperazine 10 mg IV

4. Prophylactic treatment of migraine

Propranolol 80-320 mg OD

Timolol 20-60 mg OD

5. Anticonvulsant

Sodium valproate 250 mg BD

6. Tricyclic antidepressants

Amitriptyline 10-50 mg HS

Nortriptyline 25-75 mg HS

7. MAO inhibitors

Phenelzine 15 mg TDS

8. Serotonergic drugs

Methylsergide 4-8 mg OD

Cyproheptadine 4-10 mg OD

9. Others

Verapamil 80-480 mg OD

10. Ketorolac tromethamine – 30-60 mg IM or IV.

11. Prochlorperazine 5-10 mg IV (caution – hypotension, dystonia)



12. Opiate analgesics meperidine 50 mg or methadone 10 mg or fentanyl 0.1 mg or hydromorphone 2 mg IM or IV.

Abortive Therapy

Ergotamine (3 mg orally), sumatriptan (100 mg orally or 6 mg subcutaneously)

Prevention

β blockers (60 to 240 mg), tricyclic antidepressants (amitriptyline—30 to 100 mg), anticonvulsants (valproate—500 to 2000 mg), verapamil (120 to 180 mg), phenelzine (45 to 90 mg), and methysergide (4 to 12 mg) are tried.

C. CLUSTER HEADACHE

Prophylaxis

It is given by prednisone, lithium, methysergide, ergotamine and verapamil. For chronic form, lithium 600 to 900 mg daily has been tried.

Treatment

- Oxygen inhalation for 15 minutes (9 L/min) is most effective during attacks.
- Intranasal lidocaine to the most caudal aspect of inferior nasal turbinate can cause sphenopalatine ganglionic block which can terminate an attack.
- Sumatriptan 6 mg subcutaneously shortens an attack to 10 to 15 minutes.

D. TENSION HEADACHE

Aspirin 0.6 g or acetaminophen 0.6 g every 4 to 6 hours.

E. LUMBAR PUNCTURE HEADACHE

Intravenous caffeine sodium benzoate given over a few minutes as a 500 mg dose will terminate headache in 75% of patients.

A second dose relieves headache in another 10% of patients.

If it fails, an epidural blood patch accomplished by injection of 15 mL homologous whole blood relieves headache in the rest (sealing of dural hole with blood clot).

F. GIANT CELL ARTERITIS

Prednisone in a dose of 1 mg per kg body weight daily for first 4 to 6 weeks and tapered gradually.

Benign Intracranial Hypertension

The patient presents with signs of increased intracranial hypertension. It mainly affects young woman.



Causes

- Obesity
- Endocrine causes:
 - Cushing's disease
 - Hypoparathyroidism
 - Amenorrhoea
- Drugs
 - Oral contraceptives
 - Excess vitamin A
 - Nitrofurantoin
 - Tetracycline
 - Steroid withdrawal
- Severe anaemia.

Classification

Types of the tumour	Common site	Age of occurrence	Incidence out of 50%
Benign			
*1. Meningioma	Cortical dural, parasagittal sphenoid ridge, suprasellar olfactory groove	Adults	20
2. Neurofibroma	Acoustic neuroma	Adult	1
3. Craniopharyngioma	Suprasellar	Childhood/adolescence	1
4. Pituitary adenoma	Pituitary fossa	Adult	2
Malignant			
*5. Glioma (astrocytoma)	Cerebral hemisphere Cerebellum Brainstem	Adult Childhood/adult Adult/childhood	10
6. Oligodendroglioma	Cerebral hemisphere	Adult	1
7. Medulloblastoma	Posterior fossa	Childhood	5
*8. Ependymoma	Posterior fossa	Childhood/adolescence	10

Tumors of cerebral hemispheres are uncommon in childhood.

*Common tumours



Clinical Features

- Headache and vomiting
- Significant papilloedema
- VIth nerve palsy (false localising sign)
- Enlargement of blind spot.



Investigations

CT and MRI—Small ventricles, no midline shift, no mass lesion

Lumbar puncture—Raised CSF pressure, CSF biochemistry normal



Management

- Acetazolamide and diuretics to decrease the formation of CSF
- Regular LP to reduce the CSF pressure
- If vision is threatened, surgical decompression of optic nerves.

Neoplastic Disease of the Central Nervous System

Spinal Cord Tumours (Excluding Secondaries)

Classification

1. Extramedullary (80%)
 - a. Extradural (20%)—Chordoma, sarcoma
 - b. Intradural (60%)—Meningiomas, neurofibromas
2. Intramedullary (20%)—Gliomas, ependymomas.

Neurofibroma (NF)

1. Neurofibroma usually arises from spinal roots (posterior more frequently than the anterior).
2. It may be single or multiple.
3. It rarely grows out through the intervertebral foramen, forming a dumb-bell shaped tumour and is palpable in the extraspinal portion.
4. It develops at any level of the spinal canal and occurs equally in both sexes.
5. It can also affect VIIIth cranial nerve (acoustic neuroma) in which papilloedema occurs late.

Meningioma

1. It arises from arachnoid covering of the roots or the cord.

2. Almost always it lies in the dorsal region.
3. It occurs more often in females than males.
4. It accounts for 20% of brain tumours.

Cerebral Tumours

It accounts for 2% of deaths; 50% of tumours are primary and remaining 50% brain tumours are metastases from other sites. Tumours of cerebral hemisphere are common in adult and of the brainstem in childhood.



Clinical Features

1. Signs of intracranial tension (headache, projectile vomiting, bradycardia, arterial hypertension and papilloedema).
2. Focal neurological deficit (depends upon involvement of anatomic site of the tumour).
3. False localising signs.
 - a. Unilateral/bilateral VI nerve involvement due to compression of the nerve trunks as they cross the apex of petrous part of temporal bone.
 - b. Bilateral extensor plantar or grasp reflexes (due to ventricular dilatation in hydrocephalus).
 - c. Unilateral III nerve palsy or facial pain/sensory loss (trigeminal neuralgia due to compression of gasserian ganglion as a result of tentorial herniation).
 - d. Ipsilateral extensor plantar response due to compression of opposite cerebral peduncle against free tentorial edge in tentorial herniation (Kernohan's sign).
 - e. Cerebellar dysfunction resulting from a massive frontal lesion due to downward displacement of brainstem.
 - f. Bilateral, fixed dilated pupils and defects of upward conjugate gaze due to central cerebellar lesion displacing the midbrain upwards.
4. *Focal/generalised seizures*: The occurrence of seizures depends upon the area of the cortex involved. The development of focal motor or sensory seizures in adult may suggest the possibility of a tumour.
5. *Altered sensorium*: It ranges from drowsiness to coma; it is also related to the level of intracranial pressure.



Investigations

1. *CT scan*: It is a definite investigation for localisation and detection of cerebral tumours (Figs 8.101 to 8.104).
2. *Plain X-ray of the skull*: It has the least diagnostic value with the exception of the pituitary tumours and calcified neoplasms (oligodendroglioma, craniopharyngioma and meningiomas).

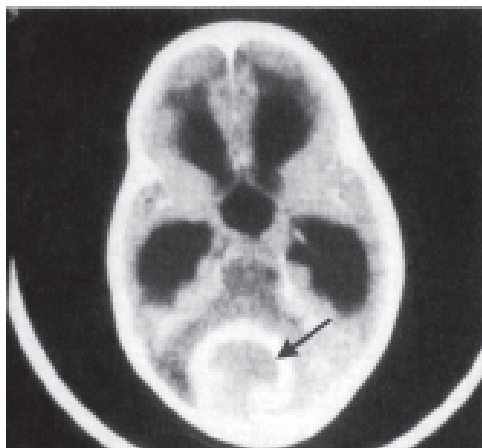

Fig. 8.101: CT brain—posterior fossa SOL with ring enhancement and hydrocephalus

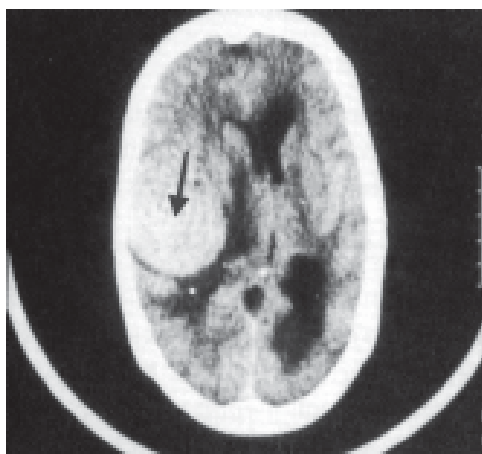

Fig. 8.102: CT brain—solitary metastasis

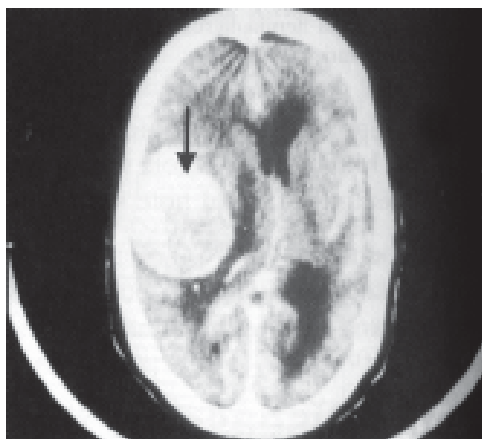

Fig. 8.103: CT brain with contrast—solitary metastasis shows enhancement

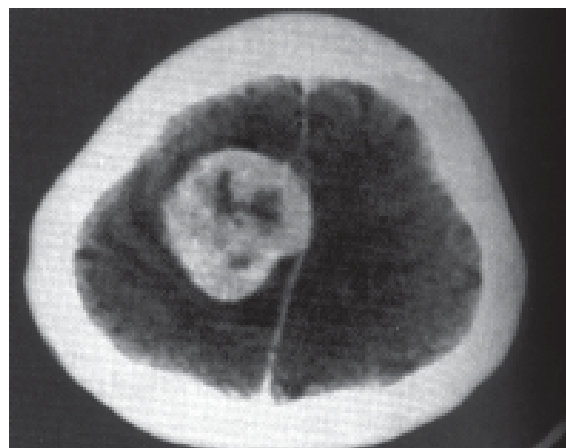

Fig. 8.104: CT brain—left parasagittal meningioma

3. *Chest X-ray:* It is an important investigation and provides evidence of primary malignancy or metastases in the lung.
4. *Cerebral angiography:* It is useful in identifying malignant tumours (presence of angiographic 'blush'). It also helps in assessing the vascularity to aid in further management either by embolisation or by surgical means.
5. *MRI:* Procedure of choice in evaluating neurologic dysfunction in patients with brain tumours. It delineates metastatic and primary tumours of nervous system. Lesions of skull base, brainstem, cerebellum and spinal cord are well delineated. Flow void MRI images provide tumour vascularity and hence may obviate the need for preoperative angiography. Haemorrhage in tumours (lipoma, epidermoid tumours, craniopharyngioma) and fat containing tumours are better recognised by MRI.



Management

1. Surgical treatment is the only definite treatment.
2. Medical management is useful for reducing the cerebral oedema.
 - a. Dexamethasone 8 mg qid (or) methyl prednisolone 50 mg qid.
 - b. Anticonvulsants (to control seizures).
 - c. Bromocriptine for prolactinoma and growth hormone secreting tumours.
3. *Radiotherapy:* Tumours sensitive are secondaries, glioblastoma, medulloblastoma, nasopharyngeal carcinoma, cerebellar astrocytoma, haemangioblastoma and pontine glioma.



Shifts and Herniations in CNS

There are three types of herniations (Fig. 8.105).

Type and Contents	Effect - Consequences
1. Subfalcine (Cingulate) herniation: Part of one cerebral hemisphere is shifted under the falx towards the opposite side	Altered conscious level—focal signs may be absent—silent unless the anterior cerebral artery is compressed resulting in contralateral leg weakness with or without abulia
2. Transtentorial (Uncal) herniation: Medial temporal structures pass through the tentorium and press upon the oculomotor nerve	Most common type—decreased level of consciousness—dilated pupil—ophthalmoplegia—Kernohan's notch—herniated midbrain compresses the cerebral peduncle of the opposite side causing ipsilateral hemiparesis (hemiparesis contralateral to the original hemiparesis)
3. Foramen magnum (Cerebellar tonsil) herniation: Increased pressure in the posterior fossa—cerebellar herniation	Severe occipital and neck pain with neck stiffness—head retraction, ataxia, Vth nerve palsies, loss of consciousness, irregular breathing, apnoea and positive Babinski's sign

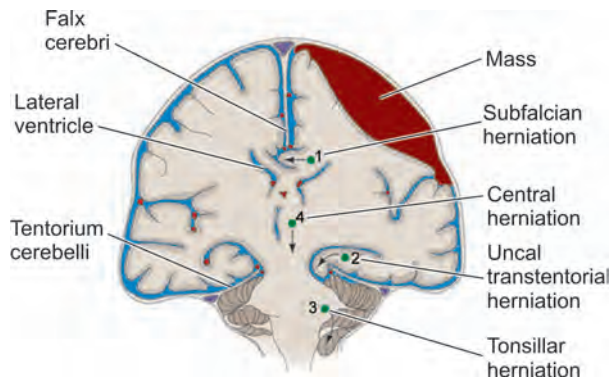

Fig. 8.105: Types of herniations

Movement Disorders

Depending on the amplitude, abnormal movements can be described as:

- Hyperkinesia (increased amplitude)
- Hypokinesia (decreased amplitude)
- Akinesia (total loss of movement).

Classification

Hypokinesia	Hyperkinesia	Miscellaneous
Characterised by poverty and slowness of movement, e.g. Parkinsonism	Characterised by abnormal involuntary movements, tremor, dystonia, chorea, athetosis, ballism, tics, myoclonus, stereotype movements, akathisia, restless legs, paroxysmal dyskinesia	Ataxic gait disorders, hyperreflexia, hemifacial spasm, myokymia, stiffman syndrome, psychogenic

Parkinson's Disease

It is a movement disorder of unknown aetiology due to degeneration of the neurons in the nigrostriatal dopaminergic system.

There is an imbalance between dopamine and acetylcholine neurotransmitters (either an increase in acetylcholine or a decrease in dopamine level).



Clinical Features

A. Motor

1. General

- Expressionless face with staring look with infrequent blinking
- Greasy skin
- Soft, rapid, indistinct monotonous speech
- Flexed posture (universal flexion).

2. Gait

- Patients walk with short steps, with a tendency to run (as though they catch their own centre of gravity)
- Slow to start walking
- Shortened stride
- Rapid small steps, tendency to run (festination)
- Reduced arm swinging
- Impaired balance on turning
- Propulsion and retropulsion and lateropulsion
- Kinesia paradox (patients can run fast during emergency).

3. Tremor

Resting tremor (4–6 Hertz)

- Usually first in fingers/thumb

- Coarse, complex movements, flexion/extension of fingers (pill rolling and drumbeating movements)
- Abduction/adduction of thumb
- Supination/pronation of forearm
- May affect arms, legs, feet, jaw, tongue
- Intermittent, present at rest and when distracted
- Diminishes on action and disappears during sleep.

4. Rigidity

- It is seen predominantly in the limbs
- Cogwheel type, mostly appreciated in upper limbs especially in wrist joints (there is a phasic element to stiffness in all directions of movement)
- Plastic (lead pipe) type, mostly appreciated in the legs and trunk
- In the trunk, rigidity manifests itself by the presence of a flexed, and stooped posture.

5. Hypokinesia

- Slowness in initiating movements
- Impaired fine movements, especially of fingers
- Poor precision of repetitive movements
- Handwriting—micrographia.

B. Non-motor

- Neuropsychiatric symptoms – anxiety, depression, psychosis, dementia, impulse control disorder
- Autonomic failure
- Sensory symptoms.

Staging

Grading	Clinical features
Grade I	Unilateral involvement
Grade II	Bilateral involvement
Grade III	Bilateral with mild postural imbalance
Grade IV	Bilateral with moderate postural imbalance and requires assistance
Grade V	Bedridden

Eye Signs in Parkinsonism

Decreased blink rate
 Hypometric saccades
 Impaired smooth pursuit
 Reflex blepharospasm (glabellar, Myerson's sign)
 Blepharoclonus
 Spontaneous blepharospasm
 Oculogyric crises (postencephalitic parkinsonism)
 Reversed Argyll Robertson pupil (postencephalitic parkinsonism).

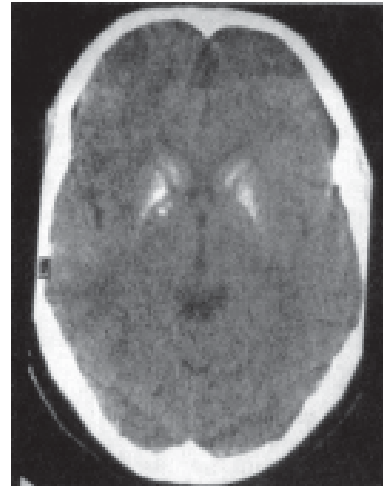

Fig. 8.106: CT brain—basal ganglia calcification in hypoparathyroidism—causing Parkinsonism



Investigations

1. Serological tests for syphilis (all patients)
2. CT brain (Fig. 8.106)
 - Indications*
 - a. Patients under age 50
 - b. Signs entirely unilateral
 - c. Atypical signs (e.g. pyramidal).
3. Tests to exclude Wilson's disease (in young patients (2nd to 4th decade)
 - a. Serum ceruloplasmin
 - b. Serum copper
 - c. Urine copper
 - d. Liver function tests.
4. MRI brain (Figs 8.107 and 8.108).

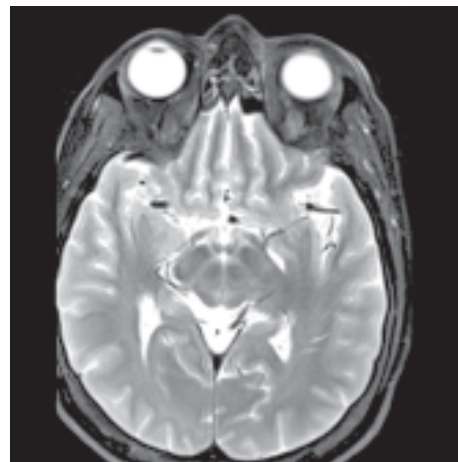

Fig. 8.107: MRI normal—Pars compacta and reticularis with red nucleus



Causes of Parkinsonism

Mechanism	Example
Impaired release of dopamine	Idiopathic Parkinson's disease
Drugs depleting dopamine stores	Reserpine, tetrabenazine
Toxins damaging dopaminergic neurones	Methyl-phenyl-tetrahydropyridine (MPTP), manganese
Viral infection	Encephalitis lethargica Japanese 'B' encephalitis
Trauma	Repeated head injury (punch drunk syndrome)
Blockade of striatal dopamine receptors	Phenothiazines Butyrophenones
Damage to striatal neurones	Viral infection Multisystem atrophy
Miscellaneous	Wilson's disease Huntington's disease Cerebral tumour Neurosyphilis

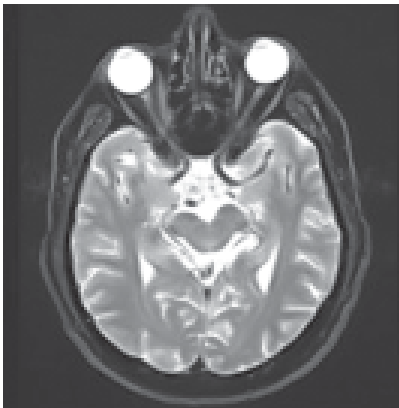

Fig. 8.108: Parkinsonism—smudging of pars compacta of substantia nigra between low signals of red nucleus and pars reticularis

Rx Treatment

1. Treat the underlying disease
2. Withdraw the drugs in drug-induced parkinsonism
3. Drug therapy.
 - I. *Drugs*
 - Dopamine agonists
 - Carbidopa/levodopa
 - MAO-A inhibitors
 - MAO-B inhibitors
 - COMT inhibitors
 - Amantadine
 - Anticholinergics
 - II. *Neuroprotective agents*
 - L-carnitine
 - Co-Q

- Creatine monohydrate
- Dopamine agonists
- Selegiline

III. *Surgery*

- Deep brain stimulation
- Substantia nigra ablation

IV. *Neurotransplantation*

- Stem cell
- GDNF infusion (Glial cell derived neurotrophic factor)

Non-motor symptoms:

- Anti-depressants – Tricyclic anti-depressants, SSRI
- Dementia – Donepezil, Rivantigmine
- Psychosis – Atypical antipsychotics

Principles of Drug Therapy

- a. Avoid anticholinergics in old age (to avoid urinary retention and glaucoma)
- b. Selegiline and bromocriptine can be used in all ages
- c. Avoid early use of L-dopa
- d. Avoid intake of vitamin B₆ along with L-dopa
- e. *Neuroprotective therapies.*

Neuroprotectives halt or delay the nigrostriatal degeneration. Neurorestorative therapies not only halt, but restore normal or near normal function in surviving neurons.

- a. *Monoamine oxidase inhibitors:* Selegiline blocks oxidative enzyme MAO-B, it induces secretion of neurotrophic factors, increase formation of oxidative enzyme superoxidases dismutase, alter glutamate receptor activity, and blocks apoptosis. Rasageline is a newer selective MAO-B inhibitor.
 - b. *Free radical scavengers:* Vitamin E is a free radical scavenger which is tried.
 - c. *Neurotrophic factor:* Glial derived neurotrophic factor can protect and rescue nigral neurons.
 - d. *Neuroimmunophilin:* Immunophilins are proteins that serve as receptors to immunosuppressant drugs. Immunophilin ligands has been found to stimulate neurite growth
 - e. *Glutamate antagonist:* Remacimide .
4. *Surgery*—stereotactic thalamotomy and palidotomy.
 5. *Supportive therapy* (physiotherapy and speech therapy).

Parkinsonism Plus Syndromes

It refers to disorders in which the classical signs of parkinsonism are combined with other signs of neurological dysfunction, particularly autonomic, cerebellar, oculomotor or cortical.

- Progressive supranuclear palsy
- Multiple system atrophy
 1. Shy-Drager syndrome

**Treatment of Parkinsonism**

Stage	Features	Drugs
Early (stage I and II)	Tremor Rigidity	<i>Under age 65</i> Anticholinergics Amantidine <i>Over age 65</i> Avoid anticholinergics Amantidine <i>All ages</i> Deprenyl 5 mg bd (selegiline) (MAO-B inhibitor)
Moderate (Stage III)	Tremor Rigidity Hypokinesias	a.*L-DOPA combinations b. Anticholinergics c. In younger patients consider low dose bromocriptine + L-DOPA combinations. Frequent small doses of L-DOPA combination are preferred.
Severe (Stage IV)	Tremor Rigidity Hypokinesias Dyskinesias Fluctuations	Frequent small doses of L-DOPA combination (1.5-3 hourly) ± selegiline 10 mg/d ± low dose bromocriptine 15-30 mg/d

* Carbidopa can be combined to prevent peripheral degradation of L-Dopa in the ratio of 1 : 4 or 1 : 10.

2. Olivopontocerebellar degeneration
 3. Striatonigral degeneration
- Corticobasal degeneration
 - ALS/PD/dementia complex of Guam
 - Alzheimer's disease
 - Pick's disease
 - Diffuse Lewy body disease.

Parkinsonism plus syndromes may be suspected if there is:

1. Prominent akinesia and rigidity without tremor at onset

2. Rapid progression
3. Development of neurologic signs indicating disease outside the basal ganglia.

Multisystem Atrophy

Common name	Clinical features	
	Early	Late
Shy-Drager syndrome	Dysautonomia	Parkinsonism Cerebellar signs Motor neuron disease signs with amyotrophy and corticospinal signs Ocular palsies Dementia
Olivopontocerebellar atrophy (ADCA)	Cerebellar dysfunction plus Parkinsonism	Dysautonomia Corticospinal signs
Striatonigral degeneration	Parkinsonism	Dysautonomia Cerebellar signs

Motor Neuron Disease

Motor neuron disease is a disease of motor neurons and refers to progressive involvement of upper or lower motor neurons, without sensory system involvement. It is a disease of unknown origin which leads to degeneration of Betz cells, pyramidal fibres, cranial motor nerve nuclei and anterior horn cells.

Genetic Classification

- I. Upper and lower motor neurons (familial ALS)
 - A. Autosomal dominant
 - B. Autosomal recessive (juvenile)
 - C. Mitochondrial
- II. Upper motor neurons
 - A. Familial spastic paraplegia (FSP)
 1. Autosomal dominant

Pathogenesis of ALS-MND

Genetic	Familial ALS mapped to chromosome 21(positive in 20% of families) Positive only in 1% of sporadic cases
Glutamate	Excitatory neurotransmitter that facilitates calcium entry into the neuronal cells inducing cell death. Glutamate antagonist Riluzole has only shown doubtful benefit.
Autoimmune	i. Possible higher instance of monoclonal paraprotein and lympho-proliferative disease ii. Association with anti-GM1 antibodies iii. Possible anti-calcium channel antibodies
Free radical accumulation	Trial with free radical scavenger, N-acetylcysteine, showed no significant benefit
Neurotrophic growth factors	No evidence of depletion of growth factors in ALS. Administration of neurotrophic factors may rescue nerve cells. BDNF and ILGF studies nearing completion.
Environmental factors	Cycas circinalis (Guamanian ALS phenotype) High iron levels



2. Autosomal recessive
 3. X-linked
 - B. Adrenomyeloneuropathy
- III. Lower motor neurons
- A. Spinal muscular atrophies
 1. Infantile: Werdnig-Hoffman disease
 2. Childhood
 3. Adolescent: Kugelberg-Welander disease
 - B. X-linked spinobulbar muscular atrophy
 - C. G_{M2} gangliosidosis
 1. Adult Tay-Sach's disease
 2. Sandhoff disease
 3. AB variant
- IV. ALS-plus syndromes
- A. ALS with frontotemporal dementia
 - B. Amyotrophy with behavioral disorder and parkinsonian features.

Amyotrophic Lateral Sclerosis

It is the most common form of motor neuron disease. It occurs mostly as a sporadic form (90–95%) and rarely familial (autosomal dominant 5–10%).



Clinical Features

1. It often starts unilaterally, later involves contralateral side, often symmetrically in a matter of a few weeks to months.
2. There is progressive muscle wasting which usually begins in the small muscles of hand (first thenar group of muscles and then forearm muscles).
3. It usually presents with UMN signs (spasticity, ↑ DTR and Babinski in the lower limbs) and LMN signs (fasciculation, wasting, weakness) in the upper limbs.
4. Foot and wrist drop may occur.
5. The characteristic feature is the recent onset of cramping with volitional movement in the early morning (during stretching in bed).
6. *Ultimum moriens* (serratus anterior, lower fibres of latissimus dorsi, upper fibres of trapezius and triceps are spared or involved very late).
7. The ocular muscles and sphincters of the bowel and bladder are characteristically spared.

8. The cause of death in motor neuron disease is respiratory paralysis.



Differential Diagnosis

1. Compressive myelopathy at cervicomedullary junction or spinal cord especially at cervical region (root pains, segmental sensory loss are against the diagnosis of MND)
2. Syringomyelia (dissociated sensory loss is against the diagnosis of MND)
3. Subacute combined degeneration (posterior column and lateral column involvement)
4. Chronic lead poisoning (only LMN signs)
5. Poliomyelitis (flaccidity; no UMN signs).

Poor Prognostic Factors

1. Respiratory muscle involvement
2. Increased CSF proteins
3. Autonomic dysfunction.

Progressive Muscular Atrophy (Predominant LMN Involvement)

1. It contributes to 10% of the cases of motor neuron disease.
2. The male : female ratio is 5 : 1.
3. It presents with diffuse wasting and weakness of hand muscles and gradually progresses to involve proximal part of limbs.
4. Deep tendon reflex is diminished or absent.
5. This has best prognosis of all motor neuron diseases.

Progressive Bulbar Palsy

It comprises 20–30% of ALS, and may have initial bulbar symptoms (unilaterally or bilaterally).



Clinical Features

1. Orbicularis oris muscle is the first muscle to be affected.
2. Other muscles affected are muscles of the jaw, other facial muscles, tongue, pharyngeal and laryngeal muscles.

Clinical Classifications

Disease	Features	Incidence	Prognosis
1. Amyotrophic lateral sclerosis (ALS)	UMN & LMN signs (pyramidal tracts and anterior horn cells)	50%	5 years
2. Progressive muscular atrophy (PMA)	LMN signs (anterior horn cells)	10%	10 years
3. Primary lateral sclerosis (PLS)	UMN signs (pyramidal tract)	5%	3 years
4. Progressive bulbar palsy (PBP)	LMN signs (cranial nerve nuclei)	25%	2 years
5. Pseudobulbar palsy	UMN signs (corticobulbar fibres)	10%	2 years

**Other Causes of Bulbar Palsy**

Disease	Test
Motor neurone disease	ENMG
Thyrotoxicosis	FT4 and TSH
Polymyositis	CK and biopsy
Myasthenia gravis	Anti Ach AB, Tensilon, ENMG

Exclude pseudobulbar palsy by MRI and
Local obstruction by ENT exam and endoscopy

- Wasting and fibrillations of tongue, dysarthria and dysphagia and loss of palatal and gag reflexes are seen.
- Patient dies within 6 months to 2 1/2 years due to respiratory infections, general weakness and debility.

Primary Lateral Sclerosis (Predominant UMN Involvement)

- This is usually insidious in onset beginning with spastic paraparesis of the lower limbs.
- The age of onset is > 5th decade and there is no family history.
- It has a gradually progressive course.
- It is symmetrical in distribution.
- Clinical features are limited to those with corticospinal dysfunction.

Pseudobulbar Palsy (UMN Fibres Corticobulbar Tracts) of Cranial Nerves**Clinical Features**

- Brisk DTR including jaw jerk and snout reflex and gag reflex

- Emotional instability
- Dysarthria and dysphagia
- Small spastic tongue.

The dysarthria may ultimately lead on to mutism.

Other Causes of Pseudobulbar Palsy

- Multiple sclerosis
- Double hemiplegia at or above the internal capsule
- Multiple cerebral embolism (multiple infarctions)
- Diffuse atherosclerosis (cerebral atrophy).

Variants of Motor Neuron Disease**1. Madras Motor Neuron Disease**

The salient features are:

- The age of onset is between 10–30 years.
- It has male preponderance (2 : 1).
- It accounts for 10% of motor neuron disease in South India.
- There is gradual asymmetric involvement of limbs in > 50% cases, with the slowly progressive involvement of all four limbs over many years finally manifesting as a classical amyotrophic lateral sclerosis.
- There is a weakness of facial and bulbar muscles (in 60–70%).
- Sensorineural deafness is frequent (30%).
- There is decreased serum citrate and increased serum pyruvate levels.
- The patient may present with an abnormal glucose tolerance test.
- Longevity is prolonged.

2. Monomelic Amyotrophy (MMA)

The clinical features are:

- Slow/nonprogressive wasting and weakness confined to one limb, usually in the upper limb.

Differentiation between Bulbar and Pseudo-bulbar palsy

	<i>Bulbar palsy</i>	<i>Pseudo-bulbar palsy</i>
Type of lesion	LMN- from motor brain stem nuclei (V to XII)	UMN- bilateral corticobulbar lesions
Speech	Monotonous, nasal	Spastic dysarthria
Facial muscles	Lip and facial muscles are weak	Stiff spastic facial muscles
Chewing	Saliva pools and dribbles, occasionally nasal regurgitation	Chewing trouble, food may stay in mouth or spill over and may choke
Gag reflex	Depressed	Brisk
Tongue	Atrophy with fasciculations	Small and spastic
Emotion	No emotional incontinence	Emotional incontinence



- b. It is seen all over India and age of onset is between 15 and 25 years.
- c. It has male preponderance.
- d. The characteristic pattern of muscle wasting is seen in the upper limb muscles (commonest forearm flexors, followed by small hand muscles, arm muscles biceps/triceps).
- e. The brachioradialis muscle is spared.

3. The Wasted Leg Syndrome (WLS) (LMN signs in lower limb)

- a. It is a nonprogressive unilateral wasting disease of leg muscles.
- b. The characteristic features are gross wasting of lower limb muscles mainly posterior crural (calf muscle) followed by anterior crural and quadriceps.
- c. DTR are preserved.

4. Juvenile MND of North India

- a. It is a nonfamilial disorder and the age of onset is between 10 and 30 years.
- b. Types
 - i. Group I involves distal muscles of extremities
 - Slow progression
 - No cranial nerve involvement
 - ii. Group II resembles classical ALS
 - More rapid progression.

5. Guamin ALS (locally called 'Lytico')

- a. The age of onset is between 10 and 30 years
- b. It has a more marked UMN signs
- c. Positive family history is present in 50% cases.
- d. It has a high incidence of associated Parkinsonism dementia (PD) complex.

6. Crural ALS (UMN and LMN in lower limb)

It predominantly involves lower limbs.

7. Hemiplegic Type (Mills variant)

It predominantly involves upper and lower limbs on the same side of the body.

8. MND with Dementia

The dementia is found in 5–10% of sporadic cases and 10–15% of familial cases.

9. MND with Parkinsonism

- a. It usually follows post encephalitic Parkinsonism. Parkinsonism can precede MND by months to decades.
- b. It runs a more benign course.

Secondary Causes of Motor Neuron Disease (Differential Diagnosis for MND)

1. Structural lesions
 - a. Parasagittal or foramen magnum tumours
 - b. Cervical spondylosis
 - c. Syringomyelia
 - d. Spinal cord AVM
2. Infections
 - a. Bacteria—tetanus, Lyme's disease
 - b. Viral—poliomyelitis, herpes-zoster
3. Physical agents
 - a. Toxins (lead, aluminium and other metals)
 - b. Drugs (strychnine, phenytoin)
 - c. Electric shock
 - d. Irradiation
4. Immunologic
 - a. Autoimmune
 - b. Polyradiculoneuropathy
5. Paraneoplastic syndrome
6. Metabolic
 - a. Hypoglycaemia
 - b. Hyperparathyroidism
 - c. Hyperthyroidism
 - d. Deficiency of folate, vitamin B₁₂ and vitamin E
7. Hereditary biochemical disorders
 - a. Hexosaminidase deficiency
 - b. Superoxide dismutase deficiency
 - c. Hyperlipidaemia.



Investigations

1. Electrophysiological studies
 - a. Fibrillation potentials
 - b. Positive sharp waves
 - c. Increased amplitude
 - d. Increased duration of motor unit action potentials (in addition to fibrillations and fasciculations—polyphasic potentials)
 - e. The electrophysiological dysfunction present in > 2 extremities is diagnostic of amyotrophic lateral sclerosis
2. CSF in MND
 - a. Cytology is normal
 - b. Protein is increased in 20–30% of patients with ALS
3. Serum CK levels: There is a mild to moderate rise occurring in 35–100% cases, secondary to muscle wasting.
4. Cranial MRI in MND: Gyral atrophy, decrease in precentral gyrus width and increase in central sulcus width are seen in ALS.

Treatment of ALS Complications

Dysphagia	Percutaneous gastrostomy, Advice of dietician and speech therapist
Ventilation failure	Assess vital capacity-Treat chest infection-Continuous positive airway pressure especially at night
Dysarthria	Speech therapist and Communication aids
Excessive salivation	Anticholinergics or Amitriptyline
Spasticity	Baclofen – Dantrolene–Benzodiazepine
Constipation	Increasing fluid intake



Treatment

There is no specific treatment

1. Symptomatic treatment (supportive care and speech therapy).
2. Treatment of secondary causes of motor neuron disease.
3. However, insulin like growth factors, ciliary neurotrophic factors, thyroid releasing hormone are used to improve the muscle strength (they are under trial).
4. Riluzole.

Spinal Muscular Atrophy (SMA)

Spinal muscular atrophies are a group of familial disorders associated with selective lower motor neuron involvement, with early age of onset of symptoms.



Investigations

1. Creatine kinase is moderately increased only in chronic, slowly progressive forms of SMA.
2. Electrophysiological studies
 - a. Motor nerve conduction velocity is slow
 - b. Sensory conduction studies are normal in all forms of SMA except type I in which sensory conduction is slowed and reduced in amplitude.



Management

1. There is no specific therapy for this disorder.
2. Physiotherapy
3. Genetic counselling.

Ataxic Disorders (Cerebellar and Spinocerebellar)

Ataxia may be hereditary or acquired.

Hereditary Ataxia

Hereditary ataxic disorder can be divided into four groups:

Differentiation between SMA and Motor Neuron Disease (Progressive Muscular Atrophy)

Features	SMA	Progressive muscular atrophy
1. Family history	Present	Absent
2. Age of onset	2 to 20 years	Above 40 years
3. Pattern of involvement	Asymmetrical	Symmetrical
4. Bulbar muscle involvement	Not commonly	Usually involved
5. Deep tendon reflexes	Lost	Decreased (or) absent
6. Progression	Slow	Rapid
7. Prognosis	Better	Worse

Types of SMA

Type	Onset	Inheritance	Clinical features
Type I (Werdnig-Hoffman)	Infancy	Autosomal recessive	Severe muscle wasting and weakness with associated hypotonia
Type II (Werdnig-Hoffman)	Childhood	Autosomal recessive	Slowly progressive form of SMA
Type III (Kugelberg-Welander)	Childhood and adolescence	Autosomal recessive	Proximal muscle wasting and weakness. Gradually progressive form of SMA
Distal form	Early adult life	Autosomal dominant	Distal weakness with wasting of small muscles of the hands and feet
Bulbospinal	Adult life. Affects males only	X-linked	Facial and bulbar weakness associated with proximal limb weakness



Differentiation between Primary Muscle Disease and SMA

Features	Myopathy	SMA
1. Genetic	Familial	Familial
2. Muscle bulk and power	Power grossly lost despite good bulk of muscle	Preservation of muscle power despite presence of gross muscle wasting
3. Distribution of wasting	Always symmetrical and selective	Usually asymmetrical and sometimes symmetrical
4. Group of muscles involved	Proximal group of muscles (except in myotonic dystrophy and distal myopathy)	Proximal as well as distal group of muscles
5. Predilection of muscle involvement	Biceps, brachioradialis, serratus anterior, pectorals, supra and infraspinatus, quadriceps	Hamstring muscles
6. Muscle hypertrophy	Common	Rare
7. Deep tendon reflexes	Normal or sluggish	Absent
8. Fasciculation	Absent	May be present
9. Other system involvement	Bone and heart	Nil
10. Contracture	May be present	Absent
11. Enzymes (creatine kinase)	Markedly elevated	Mild elevation may be present in chronic cases
12. EMG	Myopathic	Neurogenic
13. Muscle biopsy	Evidence of muscle dystrophy	Evidence of muscle atrophy

1. Congenital
2. Metabolic
3. Unknown aetiology of early onset
4. Unknown aetiology of late onset.

I. Congenital Ataxias

Congenital Disorders of Unknown Aetiology

1. Congenital ataxia with episodic hyperpnoea, abnormal eye movements and mental retardation (*Joubert's syndrome*)
2. Congenital ataxia with mental retardation and spasticity (includes pontocerebellar hypoplasia)

3. Congenital ataxia ± mental retardation (includes granule cell hypoplasia)
4. Congenital ataxia with mental retardation and partial aniridia (*Gillespie syndrome*)
5. Dysequilibrium syndrome (mental retardation, autosomal recessive disorder, motor delay)
6. X-linked recessive ataxia with spasticity and mental retardation (*Paine syndrome*).

Congenital Ataxia of Known Aetiology

- It is due to:
1. Cerebellar vermis or hemispherical degeneration
 2. Dysgenesis or agenesis of cerebellum
 3. Arnold-Chiari malformation
 4. Dandy-Walker syndrome.

Aetiology of Cerebellar Ataxia

Symmetric and progressive signs		
Acute – hours to days	Subacute – days to weeks	Chronic – months to years
Intoxication: Alcohol, Lithium, Phenytoin, Barbiturates Acute viral cerebellitis Postinfection syndrome	Alcoholic Nutritional deficiency (Vitamin B ₁ and B ₁₂) Cytotoxic drugs, Mercury, Gasoline, Solvents, Glue, Lyme disease	Hypothyroidism Phenytoin toxicity Paraneoplastic syndrome Tertiary syphilis (Tabes-dorsalis) Inherited diseases
Focal and Ipsilateral cerebellar signs		
Acute – hours to days	Subacute – days to weeks	Chronic – months to years
Vascular – Cerebellar infarction, haemorrhage, Subdural haematoma Cerebellar abscess	Multiple sclerosis, AIDS – (Multifocal leukoencephalopathy) Cerebellar glioma/metastasis	Congenital lesion: Chiari or Dandy-Walker malformations Gliosis secondary to vascular lesion or demyelination

**Common Symptoms of Congenital Ataxia**

1. Retarded motor development
2. Hypotonia
3. In coordination on reaching out for objects
4. Nystagmus
5. Truncal ataxia on sitting
6. Often improves with age
7. Fifty per cent AR inheritance
8. Autopsy reveals pontoneocerebellar or granule cell hypoplasia.

II. Ataxic Disorders with Known Metabolic or Other Causes**A. Metabolic Disorders****1. Intermittent Ataxic Syndromes**

- a. With hyperammonaemia
 - Ornithine transcarbamoylase deficiency
 - Arginosuccinate synthetase deficiency (citrullinaemia)
 - Arginosuccinase deficiency (arginosuccinicaciduria)
 - Arginase deficiency
 - Hyperornithinaemia
- b. Aminoaciduria without hyperammonaemia
 - Intermittent branched chain ketoaciduria
 - Isovaline acidaemia
 - Hartnup disease
- c. Disorders of pyruvate and lactate metabolism
 - Pyruvate dehydrogenase deficiency
 - Pyruvate carboxylase deficiency
 - Subacute necrotising encephalomyelopathy (Leigh's disease)
 - Multiple carboxylase deficiencies
 - Mitochondrial myopathy.

2. Progressive or Remitting Ataxic Syndromes

- Abetalipoproteinaemia
- Hypobetalipoproteinaemia
- Hexosaminidase deficiency
- Cholestanolosis
- Mitochondrial myopathy
- Gamma glutamyl cysteine synthetase deficiency.

3. Metabolic Disorders in which Ataxia may Occur as a Minor Feature

- Sphingomyelin storage disorders
- Metachromatic leukodystrophy
- Multiple sulphatase deficiency
- Late onset globoid cell leukodystrophy
- Adrenoleukodystrophy

Ceroid lipofuscinosis
Sialidosis.

Abetalipoproteinaemia

1. It is an autosomal recessive disorder
2. The age of onset is from infancy to childhood
3. Male to female ratio is 2 : 1
4. It has very low levels of lipids (especially cholesterol), low levels of fat soluble vitamins (vit A, D, E, K)
5. The essential neurological features are
 - a. Progressive ataxia
 - b. Loss of proprioceptive sensations
 - c. Areflexia
 - d. Ophthalmoplegia
6. Secondary features are
 - a. Acanthocytosis
 - b. Steatorrhoea
 - c. Retinitis pigmentosa.

Pure Vitamin E Deficiency

1. Ataxia
2. Areflexia
3. Loss of proprioceptive sensations
4. H/o malabsorption
5. Autosomal recessive disorder.
Pure vitamin E deficiency is treatable.

Cholestanolosis (Cerebrotendinous Xanthomatosis)

1. It is an autosomal recessive disorder
2. The age of onset is in the second decade of life
3. It is due to defect in bile salt absorption.

**Clinical Features**

1. Ataxia
2. Dementia
3. Spasticity
4. Peripheral neuropathy
5. Cataract
6. Xanthomas on tendon.

**Treatment**

It is treated with chenodeoxycholic acid.

Mitochondrial Encephalomyopathies

- It is a late onset ataxic disorder. It is characterised by:
- a. Ataxia
 - b. Deafness



- c. Dementia
- d. Peripheral neuropathy.

B. Disorders Characterised by Defective DNA Repair

Ataxia telangiectasia
Xeroderma pigmentosum
Cockayne's syndrome.

Ataxia Telangiectasia

1. It is an autosomal recessive disorder
2. The age of onset is in infancy
3. The male female ratio is 1 : 1
4. The essential neurologic features are progressive cerebellar ataxia, nystagmus, choreoathetoid movements, oculomotor apraxia
5. The secondary features are oculocutaneous telangiectasia, immunoglobulin deficiency (IgA), pulmonary infection and malignancies.

Xeroderma Pigmentosum

It is an autosomal recessive disorder.



Clinical Features

- a. Skin photosensitivity and malignancies
- b. Mental retardation
- c. Dementia
- d. Seizures
- e. Chorea
- f. Dystonia
- g. Ataxia.

The autopsy findings are

Neuronal loss in cerebrum, cerebellum and brainstem.

Cockayne Syndrome

It is an autosomal recessive disorder.



Clinical Features

- a. Skin photosensitivity
- b. Short stature
- c. Mental retardation
- d. Salt and pepper appearance in retina
- e. Ataxia
- f. Progeric facies (sunken eyes, prominent nose, large ears, and jutting chin).

C. X-linked Ataxia

1. Cerebellar ataxia with lower limb spasticity and hyperreflexia

2. Skeletal and cardiac abnormalities are absent
3. X-linked ataxia should be considered during genetic counseling
4. Motor conduction velocity is reduced (where as in other early onset ataxias with retained reflexes motor conduction velocity is normal).

III. Ataxic Disorders of Unknown Aetiology of Early Onset

Early onset cerebellar ataxia (onset usually before 20 years)

- a. Friedreich's ataxia
- b. Early onset cerebellar ataxia with retained tendon reflexes
- c. With hypogonadism and deafness and/or dementia
- d. With myoclonus (Ramsay-Hunt syndrome, Baltic myoclonus)
- e. With pigmentary retinal degeneration ± mental retardation and/or deafness
- f. With optic atrophy ± mental retardation
- g. With cataracts and mental retardation (Marinesco-Sjögren syndrome)
- h. With childhood onset deafness and mental retardation
- i. With congenital deafness
- j. With extrapyramidal features
- k. X-linked recessive spinocerebellar ataxia.

Friedreich's Ataxia

It is an autosomal recessive disorder

It is the most common of the hereditary ataxias

The age of onset is between 2 and 16 years.

Signs and Symptoms

Anita Harding's criteria for diagnosis of Friedreich's ataxia.

- Autosomal recessive inheritance
- Age of onset before 25 years

Within 5 years from onset

- Limb and trunk ataxia
- Absent tendon reflexes in the legs
- Extensor plantar responses
- Motor NCV > 40 m/s in upper limbs with small or absent SNAPs

NB: NCV- Nerve conduction velocity, SNAP- Sensory nerve action potential

After 5 years from onset

- Above plus dysarthria

Additional criteria, not essential for diagnosis (present in 2/3)

- Scoliosis
- Pyramidal weakness of the legs
- Absent reflexes in the upper limbs
- Distal loss of joint and position sense in lower limbs
- Abnormal ECG (cardiomyopathy)

ECG is invaluable as almost no other form of early onset ataxia is associated with cardiac disease.

Other features, present in <50%

- Nystagmus
- Optic atrophy
- Deafness
- Distal weakness and wasting
- Pes cavus
- Diabetes mellitus
- Paraesthesia
- Essential tremor
- Vertigo
- Decreased IQ

Variants of Friedreich's Ataxia

1. Early onset ataxia with retained reflexes – this condition has been mapped to chromosome 9q 13 and some have a Friedreich's ataxia trinucleotide expansion.
2. Late onset variant - Onset is between 21-30 years. Progression is slower with less frequent incidence of scoliosis and pes cavus.

Autopsy Findings

1. Degeneration of posterior column and spinocerebellar tracts
2. Loss of neurons in dorsal root ganglion
3. Degeneration of pyramidal tracts, brainstem, cerebellum.



Differential Diagnosis

1. Hereditary sensory motor neuropathy I
2. Abetalipoproteinaemia
3. Isolated vitamin E deficiency.

Prognosis

1. More than 90% of patients are chair bound by 45 years
2. Patients are unable to walk 13 years after the onset of symptoms
3. Death is early when diabetes mellitus and cardiac disease are present.



Treatment

1. Treat diabetes, cardiac failure and arrhythmias
2. Idebenone – Free radical scavenger improves myocardial hypertrophy in patients with Friedreich's ataxia (no improvement of neuronal function).

IV. Ataxic Disorders of Unknown Aetiology of Late Onset

Late onset cerebellar ataxia (onset usually after 20 years)

1. Spinocerebellar ataxia (SCA) 1 to SCA 17
2. Episodic ataxia Type 1
3. Episodic ataxia Type 2
4. Autosomal recessive late onset ataxias
5. Idiopathic late onset ataxias.

1. Spinocerebellar Ataxia Type 1—Chromosome 6

The gene product is ataxin 1.
(Olivo-ponto cerebellar atrophy)

Clinical features

1. Ataxia
2. Ophthalmoparesis
3. Pyramidal signs
4. Extrapyrmidal features like, rigidity, parkinsonian tremor.
5. Immobile facies
6. Knee and ankle jerks may be lost
7. Other reflexes are usually normal
8. Bowel/bladder incontinence.

2. Spinocerebellar Ataxia Type 2—Chromosome 12

The abnormal gene product is ataxin 2.

Clinical features

1. Ataxia
2. Slow saccades
3. Optic disc pallor
4. Retinal degeneration
5. Minimal pyramidal and extrapyramidal signs.

3. Spinocerebellar Ataxia Type 3—Chromosome 14

This is also known as Machado Joseph's disease.

The abnormal gene product is ataxin 3 or MJD-ataxin.

Clinical features

MJD is classified into 3 clinical types.

- a. Type I MJD (Amyotrophic Lateral sclerosis-Parkinsonism – Dystonia type)
 - i. Weakness and spasticity of extremities
 - ii. Dystonia of face, neck, trunk and extremities
 - iii. Slow stiff broad based lurching gait



- iv. Pharyngeal weakness
 - v. Horizontal and vertical nystagmus
 - vi. Impaired upward vertical gaze
 - vii. Ophthalmoparesis
 - viii. Facial fasciculations and myokimia.
- b. Type II MJD (ataxic type)
- i. Cerebellar defects
 - ii. Pyramidal and extrapyramidal defects
 - iii. Ophthalmoparesis
 - iv. Upward vertical gaze deficit
 - v. Facial and lingual fasciculation.
- c. Type III MJD (Ataxic-Amyotrophic type)
- i. Cerebellar features
 - ii. Distal sensory loss
 - iii. Distal atrophy
 - iv. Depressed or absent DTR
 - v. No pyramidal or extrapyramidal features.

4. Spinocerebellar Ataxia Type 4— Chromosome 16

Clinical features

1. Ataxia
2. Sensory axonal neuropathy
3. Pyramidal signs
4. Normal eye movements.

5. Spinocerebellar Ataxia Type 5— Chromosome 11

This is also known as Lincoln's ataxia.

Clinical features

1. Ataxia
2. Dysarthria.

6. Spinocerebellar Ataxia Type 6—Chromosome 19

Clinical features

1. Ataxia
2. Dysarthria
3. Nystagmus
4. Mild proprioceptive sensory loss.

7. Spinocerebellar Ataxia Type 7— Chromosome 3

The abnormal gene product is ataxin 7.

Clinical features

1. Ophthalmoparesis
2. Visual loss
3. Ataxia
4. Dysarthria
5. Extensor plantar
6. Pigmentary retinal degeneration.

8. Spinocerebellar Ataxia Type 8—Chromosome 13

Clinical features

1. Ataxia
2. Dysarthria
3. Nystagmus
4. Spasticity of legs
5. Reduced vibratory sensation.

9. Spinocerebellar Ataxia Type 9

Only one family is identified.

10. Spinocerebellar Ataxia Type 10—Chromosome 22

Clinical feature

1. Ataxia
2. Dysarthria
3. Nystagmus
4. Partial complex and generalised motor seizures.

11. Spinocerebellar Ataxia Type 11— Chromosome 15

Clinical features

1. Ataxia
2. Dysarthria
3. Vertical nystagmus
4. Hyperreflexia.

12. Spinocerebellar Ataxia Type 12—Chromosome 5

Clinical features

1. Tremor
2. Bradykinesia
3. Hyperreflexia
4. Dystonia
5. Ataxia
6. Dysautonomia
7. Dementia.

13. Spinocerebellar Ataxia Type 13—Chromosome 6

Clinical features

1. Ataxia
2. Hyperreflexia
3. Extensor plantar
4. Dysarthria
5. Dysphagia
6. Mental retardation.

14. Spinocerebellar Ataxia Type 14—Chromosome 19

It has been described in a single Japanese family.

15. Spinocerebellar Ataxia Type 15

This has been reserved for an American family with pure cerebellar ataxia with slow progression.

**16. Spinocerebellar Ataxia Type 16—Chromosome 8**

It has been reported in another Japanese family.

17. Episodic Ataxia Type 1

The genetic defect is in chromosome 1 (Potassium channel gene)

*Clinical Features*

1. Ataxia lasting for minutes
2. Provoked by startle or exercise
3. Facial and hand myokimia
4. Cerebellar signs are non-progressive.

*Treatment*

It shows good response to phenytoin.

18. Episodic Ataxia Type 2

The genetic defect is in chromosome 19 (Ca⁺⁺ channel gene).

*Clinical Features*

1. Ataxia lasting for days
2. Provoked by stress or fatigue
3. Down gaze nystagmus
4. Progressive cerebellar signs with atrophy

*Treatment*

Good response to acetazolamide.

Autosomal Recessive Late Onset Ataxia

The age of onset is 4th decade.

*Clinical Features*

1. Ataxia
2. Supranuclear ophthalmoplegia
3. Corticobulbar dysfunction
4. Pyramidal signs.

Idiopathic Late Onset Ataxia

There are three types

Type 1

The age of onset is 5th decade

*Clinical Features*

1. Progressive gait ataxia
2. Preserved coordination in upper limb
3. Mild or absent dysarthria
4. Dementia may or may not be present

5. Secondary features are
 - a. Cerebellar atrophy (most marked in vermis)
 - b. Olivary atrophy
 - c. Normal pons.

Type II

It is a rare form. The age of onset is 5th or 6th decade.

*Clinical Features*

1. Ataxia
2. Postural tremor and gross intention tremor.

Type III

It is the most common form. The age of onset is between 35 and 55 years. There is male preponderance.

*Clinical Features*

1. Ataxia
2. Peripheral neuropathy
3. Dementia

Acquired Causes of Late Onset Ataxia**1. Chronic Alcoholism**

- a. It is the most common cause of cerebellar degeneration in adults
- b. The gait ataxia is more common than the ataxia in the upper limbs
- c. Titubation of the head is present
- d. Dysarthria and nystagmus are rare.

2. Anticonvulsant (Phenytoin)

- a. Irreversible cerebellar ataxia
- b. Dysarthria
- c. Nystagmus
- d. DTR are decreased
- e. Peripheral neuropathy.

3. Hypothyroidism

- a. Gait ataxia
- b. Dysarthria and ocular dysmetria are rare.

4. Paraneoplastic Syndrome

- a. It is rare
- b. Neurological symptoms may precede those of the neoplasm by two or three years
- c. It is subacute in onset
- d. Ataxia of limbs and gait
- e. Dysarthria is common
- f. Other paraneoplastic syndromes like peripheral neuropathy and myasthenic syndrome are present



- g. Lung and ovarian carcinomas are the commonest malignancies.

5. Infections

Infections can cause acute cerebellar ataxia.

- It follows after viral infection or vaccination. In children, an underlying neuroblastoma is present in up to 50% of cases.
- Post-infectious acute disseminated encephalomyelitis—It occurs following mumps, *varicella*, influenza, rubella, infectious mononucleosis and mycoplasma pneumonia.
- Legionnaire's disease—It presents with neurological features and pneumonia.
Neurological signs include ataxia, nystagmus, ophthalmoplegia, and dysarthria.
- Malaria—*Plasmodium falciparum* causes cerebellar syndrome 2-4 weeks after the onset of fever. This may be due to immunological mechanism.
- Other infections—Cysticercosis, Lyme's disease, Borelliosis, focal cerebellar abscess due to bacterial or tuberculous infection.

Ataxia and Peripheral Neuropathy

- Refsum's disease
- Ataxia telangiectasia
- Abetalipoproteinaemia
- Tabes dorsalis
- Friedreich's ataxia
- Hereditary spastic ataxia.

Ramsay Hunt Syndrome

Progressive myoclonic ataxia—It consists of progressive cerebellar ataxia, myoclonus, and seizures.



Causes

- Unverricht-Lundborg disease
- Lafora Body disease
- Neuronal Ceroid Lipofuscinosis
- Sialidosis
- Mitochondrial diseases.

Multiple Sclerosis

It is a chronic disease, most frequently affecting young and middle aged, characterised pathologically by the presence of chronic inflammation, demyelination and gliosis (scarring) in the CNS with remissions and exacerbations of clinical symptoms and signs.

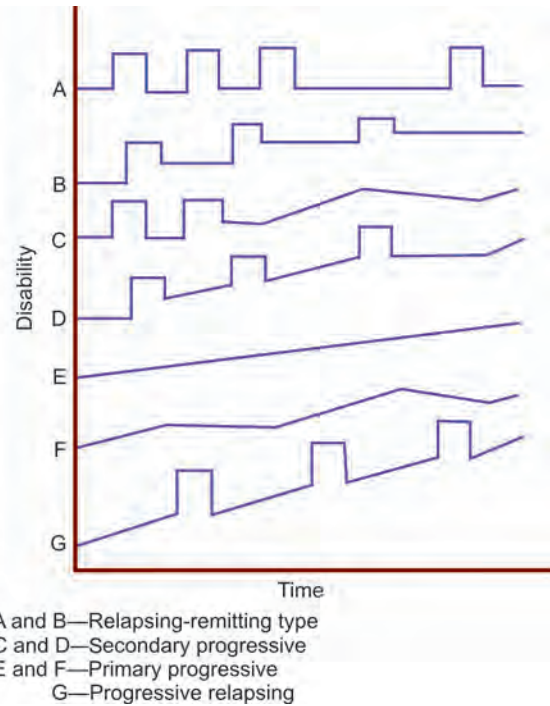

Fig. 8.109: Clinical phases of multiple sclerosis

- Age incidence – 20-40 years
- Females more affected than males
- EBV associated.



Clinical Features

It can be monosymptomatic in about 50% and polysymptomatic in another 50%.

Clinical Course of Multiple Sclerosis (Fig. 8.109)

- Relapsing remitting type (RRMS) (85%)
Patients experience relapse with or without complete recovery and are clinically stable between these episodes.
- Secondary progressive type (SPMS)
 - Starts as RRMS
 This phase is characterised by gradual progression of disability with or without superimposed relapses. Fifty per cent of relapsing remitting converts to secondary progressive from 10 years of onset.
- Primary progressive type (10%) (PPMS)
This phase is characterised by gradual progression of disability without superimposed relapses.
- Progressive relapsing type (5%)
This phase is characterised by gradual progression of disability from disease onset later accompanied by one or more relapses.

Common Presentations in Multiple Sclerosis

Mode of onset	Frequency
1. Weakness or loss of control of one or more limbs	50%
2. Visual symptoms	30%
3. Sensory symptoms	10%
4. Miscellaneous	10%

Motor

1. Initially the weakness is present only during exertion, recovering after rest, but later, as the disease progresses the weakness persists even at rest.
2. The signs are predominantly UMN as evidenced by - DTR, Babinski sign, loss of abdominal reflex (lost very early in disease).
3. Small muscle wasting of the hand and spasticity are present in advanced disease.

Sensory

1. Tingling, paraesthesia is common
2. Pain is rare but trigeminal neuralgia may be present
3. Lhermitte sign is present (shooting pain in the neck with radiation to the shoulders on flexing or extending the neck due to involvement of the posterior column).

Cerebellar Signs

These are common in established case of multiple sclerosis.

Ocular (Fig. 8.110)

1. Optic neuritis is common at the onset of disease but uncommon during the later course of the disease

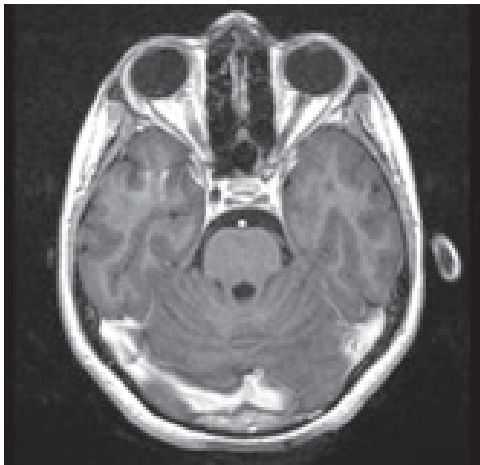

Fig. 8.110: Multiple sclerosis. Retrobulbar neuritis (right)—thickening of optic nerve

2. The other ocular signs are central scotoma, diplopia, nystagmus, retrobulbar neuritis and exaggerated pallor of the optic disc in the temporal region
3. Cranial nerve involvement (III nerve palsy, internuclear ophthalmoplegia or VI nerve palsy).

Paroxysmal Symptoms

1. Trigeminal neuralgia and/or glossopharyngeal neuralgia/hemifacial spasm
2. Facial weakness
3. Deafness and vertigo
4. Brainstem lesions (dysarthria)
5. Epilepsy
6. Mental symptoms (emotional change, euphoria, delusion and terminal dementia)
7. Bowel/bladder/sexual dysfunction.

Events Influencing the Course

1. *Pregnancy*: There is regression of symptoms and signs during pregnancy. However, overall disease course unaltered.
2. *Infections*: There is an increase in symptoms and signs either preceding or following or during infections.
3. *Inoculation*: The symptoms manifest or relapse immediately after the inoculation against a variety of infections.
4. Trauma increases the relapse rate.
5. *Uhthoff's phenomenon*: The worsening of symptoms (increased weakness and decreased vision) on exposure to heat (hot bath) or after exercise (fatigue).
6. *Emotional stress*: The symptoms may exacerbate immediately after the emotional stress.

Criteria for Diagnosis

1. CNS examination must reveal definite abnormality
2. Predominant involvement of white matter
 - Involvement of long tracts – Pyramidal, Cerebellar, MLF, optic nerve, and posterior column
3. History/clinical examination must implicate involvement of two or more areas of the CNS – MRI/Evoke response testing can be used to document 2nd lesion in the absence of clinical evidence
 - Confirmatory MRI must reveal either 4 lesions involving the white matter or 3 lesions provided one of the lesion is located in the periventricular region. Accepted lesions must be > 3 mm in diameter
 - For patients > 50 years of age, two of the following criteria must be met – (a) Size of the lesion > 5 mm (b) Lesions located adjacent to the bodies



of the lateral ventricles (c) Lesions located in the posterior fossa

4. Lesions are dissociated in time and location – 2 or more episodes involving different sites of CNS – each lasting at least 24 hours and occurring at least one month apart or gradual/stepwise progression over 6 months if accompanied by increased IgG synthesis or 2 or more oligoclonal bands -
 - MRI may be used to document dissemination in time if a new T₂ lesion or Gd enhancing lesion is seen 3 or more months after a clinically isolated syndrome
5. Patient's neurological condition could not better be attributed to another disorder.

Diagnostic Categories

1. Definite multiple sclerosis – All 5 criteria fulfilled
2. Probable multiple sclerosis – All criteria except
 - Only one objective abnormality despite 2 symptomatic episodes
 - Or only one symptomatic episode with 2 or more objective abnormalities
3. At risk for multiple sclerosis – Criteria 1, 2, 3 and 5 fulfilled
 - Patient has only one symptomatic episode and one objective abnormality



Investigations

No test is pathognomonic and diagnostic.

1. *CSF protein*: < 100 mg/dl
Cells < 75/microlitre—Mononuclear pleocytosis
2. *CSF electrophoresis*: It reveals oligoclonal bands
3. The visual, auditory and somatosensory evoked potentials are prolonged.
4. *MRI*: It is very sensitive for detecting lesions produced by multiple sclerosis (presence of periventricular plaque) (Figs 8.111 and 8.112).



Treatment

Treatment may be divided into three categories.

1. Disease modifying drugs.
 - a. RRMS.
 - Interferon β1a—30 mcg IM once a week.
 - Interferon β1b—250 mcg SC on alternate days.
 - Glatiramer acetate—20 mg S/C daily

Treatment duration for 6 months

 - b. Therapeutic decision—MS
 - In RRMS, delay initiating treatment in patients with a normal neurologic exams or a single attack or a low attack frequency or a

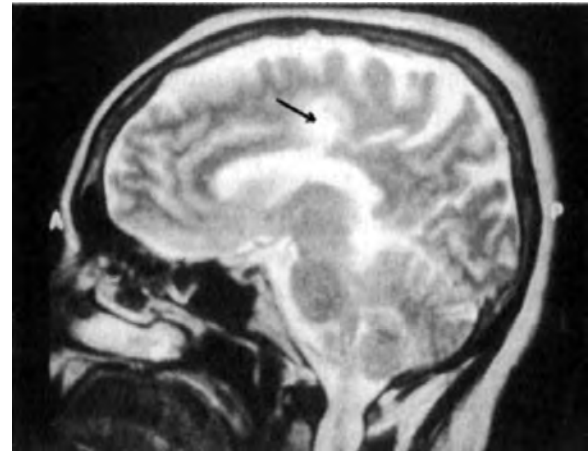

Fig. 8.111: MRI brain—periventricular plaque in multiple sclerosis

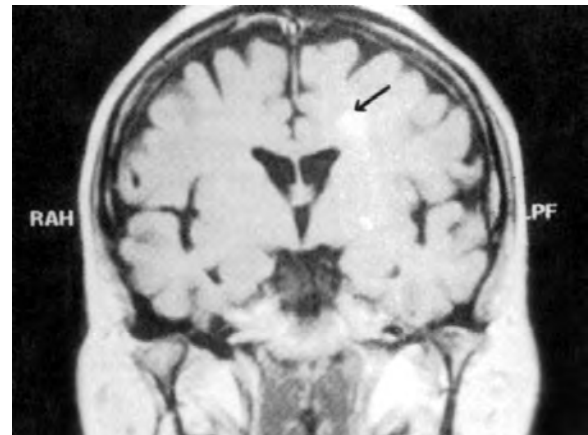

Fig. 8.112: MRI brain—periventricular plaque in multiple sclerosis

low burden of disease as assessed by brain MRI. Till they remain stable, periodic clinical exam and MRI assessment (once in 6 months or as needed).

- In case of acute exacerbation in RRMS—If there is no functional impairment, treat symptomatically. If there is functional impairment, treat with methylprednisolone or prednisone.
- Unstable RRMS—Treat them with interferon β1a or β1b or glatiramer acetate. If they do not tolerate the drug or if the response is poor, treat them with natalizumab—300 mg IV once a month.
- In SPMS—Treat them with β1a or β1b. If they do not tolerate the drug or the response is poor, consider treating them with one of the following drugs – Mitoxantrone, azathioprine,

methotrexate, pulse cyclophosphamide, IV Ig, pulse methylprednisolone.

- In PPMS—Treat them symptomatically.
- 2. Acute exacerbation—Methyl prednisolone 1 gm IV OD × 3 days followed by oral prednisolone 60 mg OD × 5 days tapering doses—2 weeks
- 3. Symptomatic treatment
 - a. Spasticity with
 - Baclofen 15-18 mg/day divided doses
 - Tizanidine 2-8 mg/d TDS
 - Diazepam 1-2 mg TDS
 - b. Pain—Carbamazepine 100-1200 mg/day
 - Gabapentine 300-3600 mg/day
 - Phenytoin 300-400 mg/day
 - Amitriptyline 25-150 mg/day
 - c. Paroxysmal symptoms—Carbamazepine, Gabapentine or Acetazolamide may be given.
 - d. Bladder hyperreflexia—Treated with anticholinergics like Oxybutinin 5 mg TDS, Tolterodine 1-2 mg BD or Propantheline 7.5-15 mg QID.

Clinical Variants

1. Neuromyelitis Optica (Devics syndrome). Acute optic neuritis with myelitis.
2. Acute MS (Marburg's variant)
It is a fulminant acute disease, usually fatal within one year.

Prognosis

1. Thirty-five per cent relapse in 5 years
2. Sixty-five per cent relapse in 20 years
3. Twenty per cent die of complications.

Meningitis

Meningitis is an infection of the pia-arachnoid and the CSF of the arachnoid space.



Causes

1. Neonates: *E. coli*
2. Children: (1 month to 15 years)
 - a. *Haemophilus influenzae*
 - b. *Streptococcus pneumoniae*
 - c. *Neisseria meningitidis*.
3. Adults
 - a. Young—*Meningococcus*
 - b. Older—*Streptococcus pneumoniae*.
4. Elderly and Immuno compromised persons
 - a. *Pneumococcus*
 - b. *Listeria*

- c. TB
 - d. Gram-negative organisms
 - e. *Cryptococcus*.
5. Viral
 - a. Enteroviruses
 - b. Herpes simplex viruses
 - c. Mumps virus
 - d. Influenza virus
 - e. Japanese encephalitis virus
 - f. Arbo viruses
 - g. Rabies virus
 - h. HIV.
 6. Nosocomial and post-traumatic meningitis:
 - a. *Klebsiella pneumoniae*
 - b. *E. coli*
 - c. *Pseudomonas aeruginosa*
 - d. *Staph. aureus*
 7. Meningitis in special situations:
 - a. CSF shunts – Staphylococcal
 - b. Spinal procedures—*Pseudomonas*.

TB Meningitis is common in extremes of age, in children and elderly.



Clinical Features (Figs 8.113 to 8.115)

Clinical features are due to inflammatory mediators and not due to direct infection.

1. Meningeal signs (positive Kernig's sign, Brudzinski's sign and opisthotonus) (Figs 8.114 and 8.115).
2. Raised intracranial pressure signs.
3. Septic signs (fever, arthritis, odd behaviour, rashes, petechiae (meningococcus), shock, DIC, tachycardia, tachypnoea).
4. Focal or generalised seizures.



Fig. 8.113: Method of examination for neck stiffness



Method of Examination for Kernig's Sign



Fig. 8.114: Stage 1—flex the hip to 90 degrees with the knee flexed



Fig. 8.115: Stage 2—extend the knee. Palpate for hamstring spasm

The meningeal signs are invariably present in 50 per cent of patients and their absence does not rule out bacterial meningitis. In 10–20% of cases cranial nerve palsy occurs (IV, VI and VII). Occasionally focal neurological deficits such as visual field defects, dysphasia and hemiparesis can occur.

Predisposing Factors

1. Head injury (fractures of base of the skull)
2. Sinusitis, mastoiditis and otitis media
3. Immunosuppressed states (carcinoma, HIV, splenectomy for sickle cell disease)
4. Diabetes mellitus
5. Pneumonia
6. Alcoholism
7. CSF shunts.
8. Iatrogenic (after LP).



Investigations

CSF Analysis

- The only investigation that will confirm the diagnosis is lumbar puncture and CSF analysis.
- Lumbar puncture is contraindicated in the presence of gross papilloedema with or without neurological deficit or meningococemia (risk of bleed). However, LP has to be planned after a preliminary CT scan.
- Early CSF analysis may be normal and the lumbar puncture should be repeated if the meningeal signs persist.
- Send 3 bottles of CSF (8 drops or ½ CC in each bottle) for urgent gram stain and culture, virology study and biochemical study (especially glucose).

CSF Glucose Decreased

1. Bacterial meningitis (markedly low in pyogenic meningitis than in TB meningitis)

Empirical Treatment of Meningitis

Age and likely micro-organisms	Choice of antimicrobials
Neonates: <i>E. coli</i> —β haemolytic streptococci— <i>Listeria monocytogenes</i>	Ampicillin + Cefotaxime
Children < 14 years: <i>H. influenzae</i> – Meningococci – <i>S. pneumoniae</i>	Cefotaxime or Ceftriaxone + Vancomycin
Adults: Pneumococci - Meningococci	Cefotaxime 2 g IV q4h or Ceftriaxone 2 g IV q12h +Vancomycin
Elderly and immunocompromised: Pneumococci – <i>Listeria monocytogenes</i> – Gram-negative organisms	Ampicillin 2 g IV q4h + Cefotaxime 2 g IV q4h or Ceftriaxone + Vancomycin 500-750 mg IV q6h
Nosocomial and post-traumatic: <i>K. pneumoniae</i> – <i>E. coli</i> – <i>S. aureus</i> – <i>Pseudomonas aeruginosa</i>	Ampicillin 2 g IV q4h + Ceftazidime 2 g IV q8h + Vancomycin 500-750 mg IV q6h

2. Carcinomatous meningitis
3. Haematomyelia
4. Epidural haemorrhage.

Encephalitis

Encephalitis is an infection of the brain. The viruses causing encephalitis are herpes simplex (most common); measles, mumps, varicella, poliomyelitis, Japanese B encephalitis and arboviruses.

No Organisms seen in CSF

Ceftriaxone 2 g IV q12h or Cefotaxime 2 g IV q4h along with Vancomycin 500-750 mg IV q6h can be given. Add additionally ampicillin 2 g IV q4h for immunocompromised and aged (>50 years).

Vancomycin should not be used alone.

Adjuvant Therapy – Dexamethasone

Dexamethasone reduces inflammation.

Dexamethasone exerts its beneficial effect by inhibiting the synthesis of IL-1 and TNF from inflammatory cells at the level of m-RNA, decreasing CSF outflow resistance and stabilising the blood brain barrier. Dexamethasone 10 mg IV should be given 20 minutes before the first dose of an antibiotic and continued 6th hourly for 4 days.

The rationale for giving dexamethasone 20 minutes before the administration of antibiotic is that it inhibits the production of TNF by macrophages and microglia only if it is given before these cells are activated by endotoxin. Do not use dexamethasone when the patient is in shock.

Symptoms and Signs

They are headache, fever, fits, altered sensorium with or without neurological deficit, signs of increased intracranial pressure, and meningeal signs.



Investigations

1. *CT scan*: It is useful to differentiate encephalitis from cerebral abscess and CNS tumours (Fig. 8.116).
2. *Lumbar puncture*: The CSF pressure is increased with increased protein and lymphocytic pleocytosis.
3. *EEG*: It shows diffuse slowing with epileptiform discharge in herpetic encephalitis.
4. *Isotope scan*: The increased temporal lobe isotope uptake on a brain scan is a feature of herpetic encephalitis.

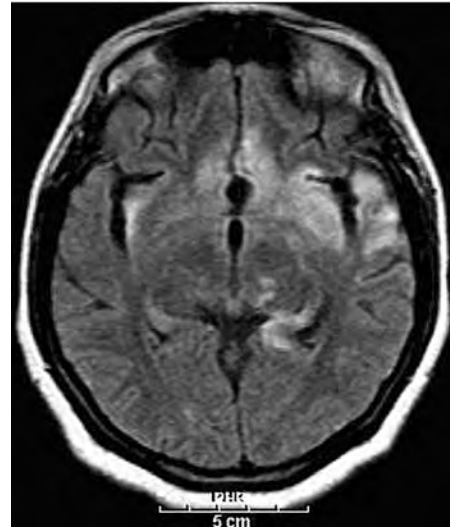

Fig. 8.116: Herpes-simplex encephalitis

5. *Brain biopsy*: It is useful in potentially treatable herpetic encephalitis.
6. The serology and immunological tests are useful in confirming the diagnosis.



Management

1. Skilled nursing care
2. Maintenance of fluid balance and nutritional status
3. The raised ICP is reduced by dexamethasone 4 mg 6th hourly
4. The herpes simplex virus encephalitis is treated with acyclovir 10 mg/kg IV 3 times daily for 10 days
5. Acyclovir 15-30 mg/kg 8th hourly for 10-14 days in viral meningitis.

Prognosis

The highest mortality is seen in herpes-simplex (mortality rate of 15–20%).

Slow Virus Disease

Slow virus diseases involving central nervous system mainly occur many months or even years after the infection with transmissible agents which have properties different from conventional viruses.

Subacute Sclerosing Pan Encephalitis (SSPE)

It has a chronic progressive and eventually fatal course. It is caused by measles virus. It occurs in children and adolescents.

It is more common between 5-15 years.



Conditions	Appearance	Cells	Glucose	Protein	Organism
Normal	Clear	Lymphocyte < 4/mm ³	2/3rd of plasma glucose level	20–40 mg%	Nil
Pyogenic	Turbid	Polymorphs 1000/mm ³	< 2/3rd of plasma glucose (40 mg%)	1–5 gm%	Present
Tuberculosis	Clear or yellow Fibrin web	PMN/LYM/mixed	< 2/3rd plasma glucose	1–5 gm%	AFB present in cob-web
Aseptic (viral)	Clear	Mononuclear 50–1500/mm ³	Normal	Normal or raised	Nil
Malignancy	Clear	Lymphocytes 0–100	Low	Normal or elevated	Nil

Treatment			
Organism	Choice of antibiotic	Dose	Duration
<i>Pneumococcus</i>	Benzyl penicillin or ceftriaxone	20 lakhs 2 hourly or 40 lakhs 4 hourly 2 gm IV 12 hourly	10 to 14 days
<i>Meningococcus</i>	Benzyl penicillin or cefotaxime	20 lakhs 2 hourly or 40 lakhs 4 hourly 2 gm IV 4 hourly	10 to 14 days
<i>Haemophilus influenzae</i>	Chloramphenicol or cefotaxime or ceftriaxone	1 to 1.5 gm IV 6 hourly 2 gm IV 4 hourly	10 days
<i>Listeria monocytogenes</i>	Ampicillin + Gentamicin	2 gm IV 4 hourly 3 to 5 mg per kg/day 8 hourly	3 to 4 weeks
Gram-negative organisms	Cefotaxime or Ceftriaxone	2 gm IV 4 hourly 2 gm IV 12 hourly	2 weeks



Clinical Features

1. Intellectual deterioration, apathy and clumsiness.
2. Myoclonic jerks, rigidity and dementia.



Investigations

1. CSF analysis:
Lymphocytic pleocytosis or acellular, markedly elevated gamma globulin (antimeasles antibodies)
2. EEG:
Periodic burst of triphasic waves.
3. Brain tissue—culture positive for measles virus (immunocytochemical methods).



Management

- Measles vaccination will prevent
- No specific treatment is available
- Isoprinosine and intrathecal INF- α may be tried.

Kuru

- The cardinal features are severe cerebellar ataxia with associated involuntary movements (choreo-athetosis, myoclonus and tremor) (Fig. 8.117).
- Mental impairment and frontal release signs.

- The source of transmission is due to ingestion of infected human brain material (cannibalistic practices).

Creutzfeldt-Jakob Disease

It mostly occurs as sporadic, although 5–15% are familial with an autosomal dominant inheritance.



Clinical Features

The clinical manifestations are severe and progressive dementia, pyramidal and extrapyramidal motor disturbances and signs and symptoms of cerebellar dysfunction.



Investigations

1. *EEG*: The typical pattern of periodic sharp wave complexes consists of a generalised slow, background interrupted by bilaterally synchronous sharp wave complexes occurring at intervals of 0.5–2.5 sec and lasting for 200–600 milli seconds
2. *CT and MRI*: This shows generalised cortical atrophy (The degree of clinical dementia is disproportionate to the amount of tissue lost)
3. *Brain biopsy*: It is the gold standard for diagnosis of Creutzfeldt-Jakob disease. The pathologic hallmarks

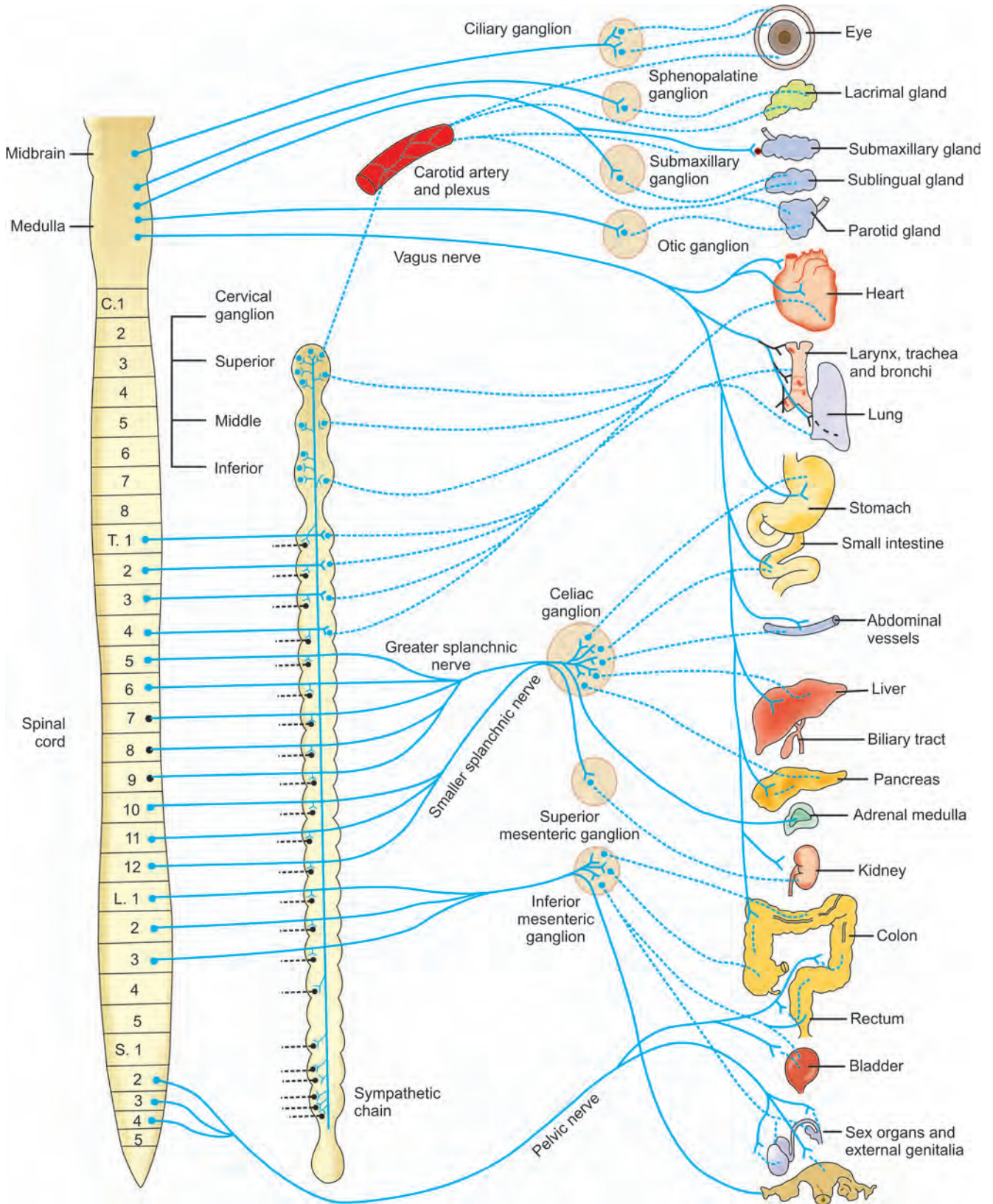

Fig. 8.117: Autonomic nervous system



are spongiform changes (small round vacuoles) within the neuropia, neuronal loss, hypertrophy and proliferation of glial cells and absence of significant inflammation or white matter involvement. The above changes are predominantly seen in the basal ganglia, cerebellum and thalamus. The brain stem and spinalcord are usually spared.

Autonomic Nervous System

Autonomic nervous system is composed of sympathetic and parasympathetic pathways. They function below the conscious level and respond rapidly to the changes that threaten to disturb the constancy of the internal environment.

Sympathetic outflow is from the lateral grey column of the spinal cord from T₁-L₂ (thoraco-lumbar outflow). This outflow communicates with the ganglionic fibres that innervate the blood vessels, heart, lungs, hair follicle, sweat glands and abdomino-pelvic viscerae.

The parasympathetic system spreads from the brainstem through IIIrd, VIIth, IXth and Xth cranial nerves and sacral segments of the spinal cord (S₂S₃S₄) (cranio-sacral outflow). They synapse in the parasympathetic ganglia and the postganglionic fibres innervate the end organs.

The sympathetic ganglia are situated in the paraspinal region, close to the cord whereas parasympathetic ganglia are situated close to the respective end organs.

Both sympathetic and parasympathetic systems are under the control of hypothalamus (anterior hypothalamus-parasympathetic, posterior hypothalamus-sympathetic) (Fig. 8.117).



Causes of Autonomic Neuropathy

Primary

1. Progressive autonomic failure (PAF)
2. Shy-Drager syndrome (multiple system atrophy)
3. PAF with Parkinson's disease.

Secondary

1. Diabetes mellitus
2. Amyloidosis

3. Autoimmune-Guillian-Barre syndrome, myasthenia gravis, rheumatoid arthritis, dysautonomia
4. Carcinomatous
5. Metabolic-porphyrria, Tangier's disease, Fabry's disease
6. Hereditary sensory neuropathy
7. CNS infections: syphilis, Chaga's disease
8. Hypothalamic/midbrain lesions
9. Spinal cord lesions (thoracic cord lesion),
10. Familial dysautonomia
11. Familial hyperbradykinism.

Drug Induced

1. Alcoholism
2. Tranquilizers, phenothiazines, barbiturates
3. Tricyclic antidepressants, MAO inhibitors
4. Vasodilator hypotensives (prazosin, hydralazine).
5. Centrally acting hypotensives (methyl dopa, clonidine)
6. Adrenergic neuron blockers (guanethidine)
7. Alpha adrenergic blockers
8. Ganglion blockers
9. ACEI: Captopril.

Bedside Cardiovascular Reflex Test

I. Parasympathetic

Tests are based on heart rate.

1. Valsalva Ratio

Procedure: Ask the patient to blow into mouth piece of a manometer and maintain at 40 mm Hg for 15 sec and record the ECG continuously. The Valsalva ratio is

$$= \frac{\text{Longest RR after the manoeuvre}}{\text{Shortest RR while blowing}}$$

Repeat the test three times and take the mean.

2. Heart Rate Response to Deep Breathing

Procedure: Ask the patient to breathe deeply and evenly at a rate of six breaths per minute and record the ECG continuously. Now calculate the difference between

Interpretation of Tests

Tests	Reference values		
	Normal	Border line	Abnormal
Valsalva ratio	≥ 1.21	1.11-1.20	≤ 1.10
Maximum-minimum heart rate during deep breathing	≥ 15	11-14	≤ 10
30 : 15 heart beat ratio on lying to standing	≥ 1.04	1.01-1.03	≤ 1
Fall in systolic blood pressure on standing	≤ 10 mmHg	11-29 mmHg	≥ 30 mmHg
Increase in DBP to sustained hand grip	≥ 16 mmHg	11-15 mmHg	≤ 10 mmHg

maximum heart rate during inspiration and minimum heart rate during expiration in each breath cycle. Repeat the test three times and take the mean.

3. Immediate Heart Rate Response to Standing

Procedure: Ask the patient to stand from the lying posture and record the ECG continuously beyond 30 beats. The 30: 15 beats ratio is calculated.

II. Sympathetic

1. Postural Fall in BP

Procedure: Record the BP of the patient in lying posture and then on standing for atleast three minutes. The postural fall of systolic BP is noted.

2. BP Response to Sustained Hand Grip

Procedure: First estimate the maximum voluntary contraction (MVC). Now maintain the hand grip at 30% of MVC upto a maximum of 5 minutes. Then measure the BP every minute. Now calculate the difference between diastolic BP just before release of hand grip and that after starting.

Objective Tests

	Post-ganglion	Pre-ganglion
QSART	Abnormal	Normal
TST	Abnormal	Abnormal

QSART: Quantitative pseudomotor axon reflex test.
TST: Thermoregulatory sweat test.



Management

- a. Treatment of postural hypotension
 1. Withdraw drugs that may exacerbate postural hypotension.
 2. To sleep in as nearly a vertical position as possible (minimise the supine hypertension)
 3. Volume repletion (2 L/day)
 4. Full length elastic stockings upto and above the waist
 5. Antigravity suits worn by astronauts
 6. High salt intake (10-20 g/day)
 7. Mineralocorticoids 9 alpha fluorohydrocortisone 0.2– 0.3 mg/day
 8. Atrial pacing
 9. Indomethacin 50 mg TDS
 10. Midodrine and pyridostigmine.
 11. Desmopressin to minimise the fluid loss

12. Octreotide inhibits release of gut peptides which produce vasodilatation and hypotensive effects. (effective in post-prandial hypotension)
- b. Treat the underlying disease.

Horner’s Syndrome

Horner’s syndrome is due to involvement of sympathetic pathways to the eyes.



Clinical Features

1. Miosis
2. Partial ptosis
3. Enophthalmos
4. Anhidrosis
5. Absence of ciliospinal reflex.

Congenital Horner’s

It is characterised by light colour of the iris and ipsilateral facial hemiatrophy.

Acute Horner’s

It is characterised by ocular hypotonia.

Features	Peripheral Horner’s	Central Horner’s
Site	Distal to superior cervical ganglion (postganglionic)	Proximal to superior cervical ganglion (preganglionic)
Sweating	*Sweating is not affected	Sweating is affected over same side head, neck, arm, upper trunk
1% Hydroxy-amphetamine test	No effect	Dilatation
Adrenaline 1 : 1000	Dilatation and lid elevation	No effect
Ciliospinal reflex	Absent	Present

* Postganglionic fibres subserving sweating (sudomotor fibres) pass along external carotid artery whereas the rest of the cervical sympathetic fibres travel along internal carotid artery.
NB: 4% cocaine is useful to differentiate between simple anisocoria and Horner’s syndrome. There is no effect in Horner’s syndrome and pupil dilate in simple anisocoria



Causes

1. Cerebral Hemispherectomy or massive infarction
2. Brainstem Wallenberg’s syndrome
Multiple sclerosis
Pontine glioma



- | | |
|--|---|
| 3. Cervical cord | Syringomyelia, Ependymomas, Gliomas |
| 4. Cervical sympathetic chain | Thyroid carcinoma, and surgery, cervical tumour and trauma |
| 5. Thoracic root level (D ₁) | Pancoast tumour
Cervical ribs
Aortic aneurysms
Klumpke's paralysis |
| 6. Other causes | Migraine
Carotid artery thrombosis. |

The Spine

The spine is the back bone of the human body and it protects the spinal cord. It is the shock absorber. It has three main curvatures at cervical (lordosis), thoracic (kyphosis) and lumbar (lordosis) levels.

Movement of the Spine

Nodding of the head occurs at the atlanto-occipital joint and rotation at the atlanto-axial joint. Flexion, extension and lateral flexion occurs at the midcervical level. Thoracic spine is relatively fixed and there is only a very little flexion, extension, lateral flexion and the main movement being rotational. Similar to cervical spine, the lumbar spine is mobile and the main movements being flexion, extension and lateral flexion.

Curvature Disorders

- Increased cervical lordosis—Ankylosing spondylitis
- Loss of cervical lordosis—Acute lesions, rheumatoid arthritis, cervical spondylosis
- Flexion deformity of cervical spine—Rheumatoid arthritis
- Lateral flexion (Cock Robin position)—Erosion of lateral mass of atlas in RA
- Loss of lumbar lordosis—Acute disc prolapse, aging, ankylosing spondylitis
- Increased lumbar lordosis—Muscular dystrophies
- Gibbus/Kyphosis—Tuberculosis, tumour, osteoporosis
- Scoliosis—Postural (correctable on flexion), Congenital, unequal limb length, acute disc prolapse, extensive fibrosis of the lungs, inflammatory disorders
- Kyphoscoliosis—Congenital, poliomyelitis, neuromuscular disorders.

Sites of Lesion

Steele's rule of third states that at the upper cervical level (C₀-C₂) of the spinal canal, the spinal cord occupies

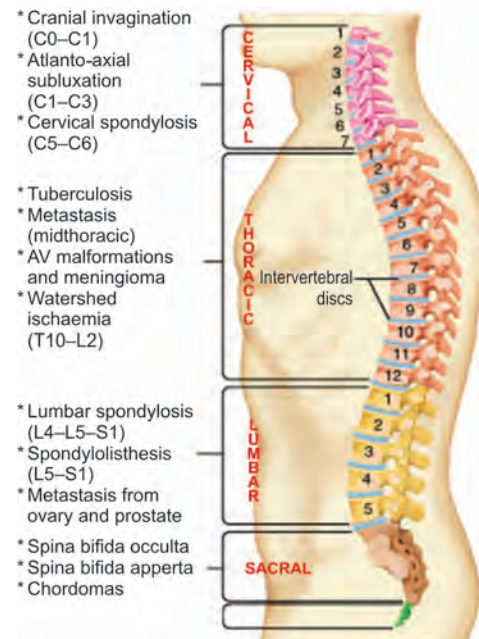

Fig. 8.118: Sites of lesions in spine

1/3rd of space, dens occupies 1/3rd of space and the remaining 1/3rd forms the free space. Increased mobility at the cervical and lumbar level and the compromised spinal canal space due to cervical and lumbar enlargement of the spinal cord contribute to the increased incidence of root and cord compression at these levels (Fig. 8.118).

Cervical Spine

C₀ - C₁: Cranial invagination - Dens entering foramen magnum can cause sudden death.

C₁ - C₃: Atlanto axial subluxation either as a result of rheumatoid arthritis or due to spondylolisthesis (Anterior subluxation of top vertebra over the adjacent lower vertebra) can cause sudden death due to brain stem compression (Similar to judicial hanging).

C₃ - C₅: Patient is ventilator dependent due to phrenic nerve involvement.

C₅ - C₆: Cervical spondylosis resulting in disc prolapse, trauma causing vertical compression injury and extension injury are common at this site. Above lesions can cause quadriplegia.

Thoracic Spine

Tuberculosis is common in thoracic spine because of its proximity to the lung. Metastasis is more common in the spine due to Batson's low pressure venous system and the common primary sources are from breast, prostate, kidneys, lungs, thyroid and gastrointestinal

system. Metastasis is more common in midthoracic level. Arterio-venous malformation and meningioma usually occur in thoracic region.

Thoraco-lumbar Spine ($T_{10} - L_2$)

Water shed ischaemia is common at this site. Pott's spine is common. The pain from these segments may radiate to the upper abdomen.

Lumbar Spine

Similar to cervical spine, because of increased mobility lumbar spondylosis ($L_4 - L_5 - S_1$) with disc prolapse and spondylolisthesis ($L_5 - S_1$) are common. Metastasis from prostate and ovary are common.

The pain may radiate to the lower abdomen.

Sacral Spine

Spinabifida occulta is common over this segment and it is due to failure of spinous process to fuse.

Spinabifida aperta – It affects the vertebral body as well as soft tissue including meningeal covering overlying these segments. Spinal chordomas are common in the sacro-coccygeal region.

Fractures

Fractures in the spine are common at junctional zones due to the relative movements of different spine segments.

- Cervico-thoracic junction ($C_5 - C_7$)
- Thoraco-lumbar junction ($T_{12} - L_2$)
- Lumbo-sacral junction (L_5)

Compressive fracture above midthoracic level is usually due to malignancy and osteoporotic compressive fracture usually occurs below midthoracic level. Neurofibromas can occur at any level.

Bone scan is sensitive for diagnosing metastasis but not specific. Bone scan is cold in myeloma. MRI is the most sensitive investigation for spinal metastasis.

Spinal Cord

Spinal cord is the long cylindrical lower part of the central nervous system. It extends from the foramen magnum in the skull to the lower border of the first lumbar vertebra. During early fetal life, the spinal cord extends to the lower border of the sacrum. But at birth it extends up to upper border of the L_3 vertebra.

Measurements

Length (cm)	Spinal cord	Vertebral column
Adult male	45	70
Adult female	42	60
Weight (gm)	30	

Spinal Cord Enlargements

1. *Cervical Enlargement* ($C_5 - T_1$; widest at C_6) (due to formation of brachial plexus, supplying the upper limb).
2. *Lumbar Enlargement* ($L_3 - S_2$; widest at S_1) (due to formation of lumbosacral plexus, supplying lower limb).

Below the lumbar enlargement, the spinal cord narrows and ends as *conus medullaris*.

Spinal cord has 31 pairs of spinal nerves (8 cervical; 12 thoracic; 5 lumbar; 5 sacral and 1 coccygeal). At cervical vertebral level the nerve roots pass above the corresponding cervical vertebra except C_8 root which passes below the C_7 vertebra. The rest of the nerve roots pass below the corresponding vertebrae. Since the spinal cord ends at the level of L_1 vertebra, the lumbar roots from L_2 and sacral roots congregate around the filum terminale in the spinal theca and are known as cauda equina. The spinal segments of $L_{4,5}$, S_1 and S_2 are known as epiconus of the cord and $S_{3,4,5}$ and coccyx are known as conus of the cord.

Vertebral column	Spinal cord segments
Lower cervical	Add 1
Upper thoracic (1-6)	Add 2
Lower thoracic (7-9)	Add 3
T_{10}	L_1 and L_2
T_{11}	L_3 and L_4
T_{12}	L_5
L_1	Sacral and coccygeal segments

Due to the difference in rate of growth of spinal cord and vertebral column, there is a discrepancy between the levels of spinal segments and vertebral bodies.

The spinal cord has an inner H shaped grey column. (anterior, lateral and posterior horns) and white column. (whiteness is due to myelination of nerve fibres). The white fibres have ascending and descending tracts.

Arrangement of Fibres (Fig. 8.119)

1. *Posterior column*: As they do not cross at the entry point in the spinal cord segments, the fibres from

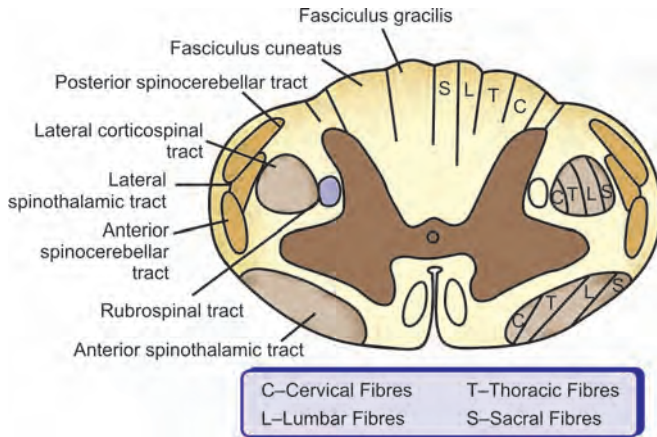

Fig. 8.119: Cross-section of spinal cord

the lower limbs are placed more medially near the central canal. The fibres from the upper limbs are placed more laterally.

- a. *Medial to lateral at cervical level:* Sacral, lumbar, thoracic, and cervical respectively.
- b. *Central canal to dorsum (anterior to posterior):* Touch, position, movement, vibration and pressure
2. Lateral column and anterior column
 - a. Corticospinal tract
 - b. Spinothalamic tract

As the fibres cross in the spinal cord, the lower limb fibres are placed more laterally, and the upper limb fibres are placed more medially at the cervical level.

Medial to lateral—Cervical, Thoracic, Lumbar and Sacral (CTLS).

Blood Supply of the Spinal Cord

Spinal cord is supplied by one anterior spinal artery (anterior 2/3 of the cord) and a pair of posterior spinal arteries (posterior 1/3 of the cord). The anterior spinal artery is formed by the union of a pair of branches from the vertebral arteries. The posterior spinal arteries arise from the vertebral arteries.

Spinal cord arterial supply is augmented by radicular arteries. The radicular arteries enter through the intervertebral foramina and divide into anterior and posterior branches. The anterior branch of the radicular artery anastomoses with the anterior spinal artery and the posterior branches of the radicular artery anastomoses with the posterior spinal artery. The largest radicular artery arises from the aorta in the lower thoracic or upper lumbar region (artery of Adamkiewicz) and is the major source of blood supply to the lower 2/3 of the spinal cord. It is unilateral and in majority of people, enters the spinal cord from the left side. The anterior spinal artery gives a sulcal branch

Important Ascending and Descending Tracts of Spinal Cord (Fig. 8.120)

Anterior column	Lateral column	Posterior column
<i>Ascending tracts</i>		
1. Ventral spinothalamic tract (crude touch)	1. Dorsal and ventral spino-cerebellar tract (reflex proprioception)	Fasciculus gracilis and fasciculus cuneatus (vibration, passive motion, joint and two-point discrimination)
2. Spino-olivary tract (reflex proprioception)	2. Lateral spinothalamic tract (pain and temperature)	
	3. Spinotectal (reflex)	
<i>Descending tracts</i>		
1. Ventral corticospinal tract (voluntary motion)	1. Lateral corticospinal tract (voluntary motion)	Fasciculus inter-fascicularis and septomarginal fasciculus (association and integration)
2. Vestibulospinal tract (balance reflex)	2. Rubrospinal tract (muscle tone and synergy)	
3. Tectospinal tract (audiovisual reflex)	3. Olivospinal tract (reflex)	
4. Reticulospinal (muscle tone)		

which supplies the ventral part of the cord and a circumferential branch which supplies the periphery of the cord.

Vascular Syndromes of Spinal Cord

Anterior Spinal Artery Syndrome



Causes

1. Syphilitic arteritis
2. Aortic dissection
3. Atherosclerosis of the aorta and its branches
4. Fracture dislocation of the spine
5. Vasculitis
6. Following surgery (abdominal aorta)
7. Following repair (coarctation of aorta)
8. Vertebral artery dissection
9. Cardiac emboli.



Clinical Features

1. Abrupt onset
2. Radicular or girdle pain
3. Motor signs (flaccid quadriplegia or paraplegia) below the level of the lesion

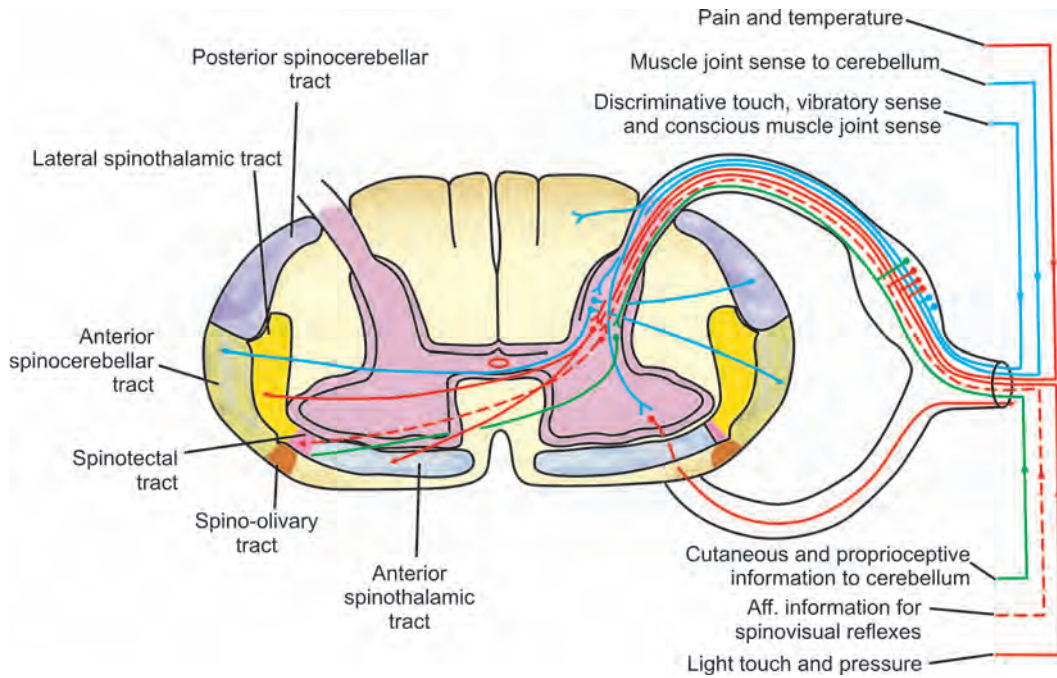

Fig. 8.120: Ascending tracts of the spinal cord

4. Sensory system disturbance below the level of lesion—thermoanaesthesia and analgesia; preservation of position sense, vibration sense and light touch
5. Impairment of bladder and bowel function.

Posterior Spinal Artery Syndrome



Clinical Features

1. Loss of proprioception and vibration sense below the level of lesion
2. Loss of segmental reflexes.

Measurement of the Spinal Canal

Region	Anteroposterior or Sagittal diameter (mm)		
	Minimum	Average	Maximum
<i>Cervical</i>			
C ₁	16	22	31
C ₂	14	20	27
C ₃	12.75	18	23
C ₄ -C ₇	12.50	17	22
<i>Lumbar</i>			
L ₁	16	20	24
L ₂	16	19	24
L ₃	15	18	22
L ₄	15	18.5	22
L ₅	15	18.5	22

Watershed Areas of the Spinal Cord

1. T₁-T₃ (due to the small posterior spinal artery)
2. T₄ (due to the small anterior spinal artery)
3. L₁ (due to the small anterior spinal artery)
4. The longitudinal plane lies at the junction of the anterior spinal artery and posterior spinal artery at all the levels of spinal cord (pyramidal tract is situated in this area and hence vulnerable).

Venous Drainage

It closely follows the arterial pattern. There are 5–10 posterior radicular veins and 6–11 anterior radicular veins.

Cervical Canal Stenosis

The sagittal diameter is < 11 mm or less than 7 mm with neck in extension.

Lumbar Canal Stenosis

1. The sagittal diameter is < 12 mm
2. The interpeduncular distance < 17 mm (transverse).

Spinal Cord Disorders

Myelopathy can be of two types.



Fig. 8.121: Gibbus in thoracic spine

I. Compressive

1. *Diseases of vertebral column*
 - a. Common: Trauma
Tuberculosis
Cervical and lumbar spondylosis
Secondaries
 - b. Less Frequent: Primary neoplasm (sarcoma, myeloma, osteoma, haemangioma)
 - c. Rare: Achondroplasia
Severe kyphoscoliosis (Fig. 8.121)
2. *High cervical cord compression: Craniovertebral junction anomalies*
3. *Other causes:*
 - a. Extradural abscess: Metastatic infection (or) Vertebral osteitis
 - b. Arachnoiditis: Syphilis, Tuberculosis
 - c. Granulomatous: Sarcoidosis, TB
 - d. Infiltration of the meninges: Reticulosis, leukaemic deposits in meninges
 - e. Cystic lesions: Arachnoid cyst and parasitic cyst (hydatid cyst, cysticercosis)
4. *Spinal cord tumours.*

II. Non-compressive Myelopathy

1. *Infective*
 - a. Viral: Poliomyelitis, herpes-zoster, rabies, CMV, EBV and HIV
 - b. Bacterial: TB, syphilis

- c. Rickettsial: Typhus fever
 - d. Fungal: Actinomycosis
 - e. Parasitic: Malaria (falciparum), Schistosomiasis, Toxoplasmosis
2. *Immunoallergic*
 - a. Influenza
 - b. Postexanthematous (measles, chickenpox, rubella)
 - c. Postvaccinal (rabies, smallpox, tetanus, poliomyelitis).
 3. *Demyelinating disease: multiple sclerosis, Devic's disease, subacute combined degeneration.*
Transverse myelitis is almost always due to infective, immunoallergic or demyelinating causes.
 4. *Heredofamilial/degenerative*
 - a. Motor neuron disease
 - b. Progressive spastic paraplegia
 - c. Spinocerebellar ataxia
 5. *Toxic*
 - a. Lathyrism
 - b. Arsenic
 - c. Tri-orthocresylphosphate (TOCP)
 - d. Intrathecal penicillin
 - e. Spinal anaesthesia
 - f. Subacute myelo optic neuropathy (SMON)
 6. *Vascular*
 - a. Arteriosclerosis
 - b. Dissecting aneurysm of aorta
 - c. Vascular anomalies of the spinal cord (angiomas, AVM, arterial embolism)
 7. *Physical agents*
 - a. Irradiation
 - b. Electrical injury
 8. *Metabolic and nutritional*
 - a. Pernicious anaemia
 - b. Pellagra
 - c. Chronic liver disease
 9. Tropical spastic paraplegia (HTLV-1)
 10. Carcinomatous myelopathy (non-metastatic).

Traumatic Lesions of the Spinal Cord

Concussion

It means transitory loss of sensory and motor functions due to edema of the cord without structural changes. The recovery is usually complete.

Contusion

It means focal disturbance of the function due to petechial haemorrhages into the cord. The recovery may or may not be complete.



Laceration

The neurological dysfunction is more than a contusion.

Whiplash or Flexion Extension Injury

The clinical features are mainly due to damage to the soft tissues, (muscle and ligaments) and stretching of nerve roots than actual trauma to the spinal cord itself.

Acute Central Cervical Spinal Cord Injury

The clinical features (more motor impairment in the upper limbs than the lower limbs with varying degree of sensory loss) are due to dislocation of the vertebral bodies at C₅ and C₆ cervical levels (severe hyperextension). The recovery (motor and sensory) is first in the legs, then in the upper limbs and finally in the hands.

Tuberculosis

It commonly affects the spinal cord by three ways:

1. Primary spinal variety
2. Secondary
 - a. TBM (intracranial)
 - b. TB vertebrae (Pott's disease)

It commonly involves the thoracolumbar region.

Compression is due to any of the following mechanisms:

1. Caries spine (Spares intervertebral disc)
2. Granulation tissues
3. Arachnoiditis
4. Vascular (endarteritis)
5. TB myelitis
6. Cold abscess
7. Tuberculoma.

Syphilis

The tertiary meningovascular syphilis usually affects both cerebrum and spinal cord. The common pathology to both forms (spinal and cerebral) are:

1. Subacute meningitis
2. Perivascular inflammations and endarteritis
3. Gumma formation.

Cranial

The clinical features are:

1. Headache, focal convulsions and paresis of limbs (cranio-pachymeningitis)
2. Multiple cranial nerve palsies, headache, confusion, impairment of memory and optic atrophy (cerebral leptomeningitis) can occur
3. Hemiplegia (cerebral endarteritis)
4. Cerebral gumma.

Diagnosis

The examination of the pupil is very important (AR pupil).

Spinal Syphilis

It affects the spinal cord

1. Cervical pachymeningitis (involvement of dura)
2. Meningomyelitis-Erb's syphilitic spastic paraplegia
It is characterised by pure motor paraplegia with early bladder involvement
3. Spinal endarteritis: It manifests as a dissociated sensory loss (due to thrombosis of anterior spinal artery)
4. Radiculitis: It presents with sensory loss and wasting.

Tabes Dorsalis

It is common in males than in females and manifests, 8–12 years after primary infection. The age of onset is mostly 35–50 years.

Pathology

It manifests as atrophy of the dorsal spinal roots, (especially lower thoracic/lumbosacral regions) the axons of dorsal root ganglia, and compression of dorsal root fibres by meningeal constrictions.

1. Optic atrophy
2. Argyll-Robertson pupil
3. The sensory fibres of V and IXth cranial nerves may also be involved.

Symptoms and Signs

1. Pain and hyperpathia due to irritation of nerve roots (lightning pain)
2. Sensory loss (interruption of reflex arc) and sensory ataxia due to posterior column involvement.
3. Loss of deep sensations (JPS, VS and Rombergism)
Abadie's sign is loss of painful sensation on squeezing the tendoAchilles or testis
4. Argyll-Robertson pupil
5. Optic atrophy
6. Areflexia.

Epidural Abscess

It is a medical emergency. It is defined as a suppurative infection of the epidural space. The predisposing factors are furunculosis of the back or scalp, bacteraemia or minor back injury. It presents as an unexplained fever of several days to two weeks duration, with mild spinal backache and local tenderness, later causing radicular pain and cord compression (Fig. 8.122).



Fig. 8.122: Epidural abscess



Treatment

Emergency decompression by laminectomy, drainage, and appropriate antibiotics after the surgery.

Epidural Haemorrhage and Haematomyelia

It is characterised by haemorrhage into spinal cord (haematomyelia) or epidural space which produces an acute transverse myelopathy evolving over minutes or hours. It is accompanied by severe pain.



Causes

1. AV malformation
2. Haemorrhage in the tumour
3. Anticoagulants



Clinical Features

The back pain and radicular pain precedes weakness by several minutes to hours. Lumbar epidural haematoma leads to loss of knee jerk and ankle jerk whereas retroperitoneal haematoma leads to loss of only knee jerk.



Investigations

CSF Analysis

In epidural haemorrhage, CSF is clear or shows a few red cells whereas in subarachnoid haemorrhage or

subdural haemorrhage, the CSF is grossly bloody. The CSF sugar is reduced.

Neurological Diseases in Patients with HIV

1. Myopathy
2. Peripheral neuropathy
 - a. GBS
 - b. CIDP
 - c. Mononeuritis multiplex
 - d. Distal symmetric polyneuropathy
3. Myelopathy
 - a. Vacuolar myelopathy
 - b. Pure sensory ataxia
 - c. Paraesthesia/Dysaesthesias
4. Aseptic meningitis
5. HIV encephalopathy
6. Neoplasms
 - a. Primary CNS lymphoma
 - b. Kaposi's sarcoma
7. Opportunistic infection
 - a. Toxoplasmosis
 - b. Cryptococcosis
 - c. Progressive multifocal leucoencephalopathy
 - d. CMV
 - e. Syphilis
 - f. Tuberculosis
 - g. HTLV 1.

Treatment is mainly symptomatic.

Cervical Spondylosis

It is a degenerative disorder involving the discs, cervical spines and joints of the cervical region. It affects men more than women.

Mechanism of Degeneration

1. Narrowing of the intervertebral disc space (due to nucleus pulposus herniation or annulus bulging)
2. Osteophytic spur formation (dorsal surface of vertebral bodies)
3. Partial subluxation of vertebrae
4. Hypertrophy of the dorsal spinal ligament and dorsolateral facet articulations.
5. Hypertrophied ligamentum flavum with fibrosis and calcification
6. C5-C6 intervertebral disc has strong attachment to the vertebral column and this predisposes to degenerative changes.

The most common intervertebral joint to undergo degenerations is between C₅-C₆. It is due to maximal movements occurring at this cervical spine. However, C₆-C₇ and at times C₄-C₅ can also be involved.

Differential Diagnosis of Leg Pain

Features	Neurological	Arterial	Venous	Rheological
Site of pain	Along a dermatome	Usually calf region	Always calf	Usually whole leg
Method of relief	Lying down for atleast 30 minutes	Standing still for few minutes	Elevation of legs	Standing still
Confirmatory signs	Abnormal neurological signs after exercise	Absent distal pulse	Oedema and other signs of chronic venous congestion	Bounding pulse
Confirmatory test	Myelogram	Ankle: arm systolic ratio < 0.8	Venogram	CBC and ESR

Symptoms and Signs

Radiculopathy

1. Neck pain (local and referred pain)
2. Sensory loss and paraesthesiae in the corresponding dermatomes (due to sensory root involvement)
3. Weakness and wasting of the muscles supplied (due to motor root involvement) and inverted biceps reflex (C₅ lesion)
4. The wasting of the small muscles of the hand is uncommon.

Spurling's Sign

In cervical spondylosis, cervical extension results in narrowing of the vertebral canal thereby producing severe pain in neck.

Shoulder Abduction Relief Sign

Abduction of shoulder relieves pain in cervical spondylosis.

Cervical Angina Syndrome

C6–C7 disc prolapse can cause pain over the chest simulating angina.

Myelopathy

The most common presentation is spondylotic myelopathy. It presents with insidious onset of spastic weakness of the legs, dragging of the toes and stiffness of the legs. An accompanying radiculopathy is reported in 40–80% of cases. The features of root involvement are asymmetric, asymptomatic or present with focal weakness or wasting or loss of a reflex.

The sensory signs (loss of VS, PS, Rombergism +) in myelopathy is due to posterior column involvement.



Differential Diagnosis for Cervical Spondylosis

1. Compression of cord or root (TB, secondaries or neurofibromas)
2. Carcinomatous infiltration or radiotherapy.
3. Peripheral nerve lesions (distal ulnar or median nerve)
4. Motor neuron disease
5. Syringomyelia
6. Multiple sclerosis

Lumbar Canal Stenosis

It is a congenital disorder causing narrowing of the lumbar canal. Symptoms are exacerbated by degenerative changes. The narrowest part of the lumbar canal is present between L₄ and L₅ vertebrae. It is the most common condition causing cauda equina lesion.

Predisposing Factors

Achondroplasia
Spondylolisthesis
Acromegaly.

Mechanism

1. The compression by the disc causes further narrowing of the canal during erect posture
2. The physiological hyperemia occurring during exercise.



Clinical Features

1. It is three times more common in men than women
2. The age of onset is 40–50 years
3. There is history of postural low backache (the pain is provoked by sitting, standing, bending or lifting)



- There are symptoms of neurogenic claudication (appearance of pain, numbness in the legs during walking).

The signs are:

- Stiffness of the lumbar spine
- Reversal of normal lordosis
- Stooped posture
- Absence of ankle reflex.

Differentiation between Intervertebral Disc Prolapse and Lumbar Canal Stenosis

Features	Intervertebral disc prolapse	Lumbar canal stenosis
Age	3–4 decade	4–6 decade
Onset	Acute	Gradual
Pain	Back and lower limb	Back and lower limb
Neurogenic claudication	May be positive	Rapid onset
SLR	Restricted	Normal
Sitting posture	Aggravation of pain	Pain not aggravated
*Pain relief on stooping	—	Present
* Stoop test		

Procedure

- Ask the patient to walk
- Ask the patient to continue to walk even after the development of neurogenic claudication.
- Patient continues his walk with a stooped posture.

Characteristics of Neurogenic Claudication

- Pain is not in the exercising muscle but along the dermatome
- Patient cannot walk but may be able to cycle long distance
- During the episode reflexes are usually absent
- In early stages, pain is relieved by sitting and stooping position
- Elevation of the limb does not relieve pain.



Investigations

1. Measurement of Movement of the Spine

Procedure

- Mark 2 points over skin about 10 cm above and 5 cm below L₅ vertebra in the midline with the patient erect. (total 15 cm)
- Ask the patient to bend forward as far as possible. Normally interpoint distance increases by more than 5 cm. (i.e. more than 20 cm) (Fig. 8.123).



Measuring forward flexion of spine

Fig. 8.123: Schober's test

Interpretation: In disc prolapse, the interpoint distance is less than 20 cm due to restricted movement on bending forwards.

2. Plain X-ray Neck

Anteroposterior

Lateral-Neutral

Flexion

Extension

Oblique (for delineating intervertebral foramina)

Features

- Loss of normal cervical lordosis
- Spondylotic bars
- IV disc narrowing and subluxation
- Reduction of sagittal diameter is less than 11 mm or 7 mm (in neck extension).

3. Plain X-ray Lumbar Spine AP and Lateral View

- Inter pedicular distance decreased
- AP diameter < 15 mm

AP diameter of canal × inter pedicular distance

$$\frac{\text{AP diameter of body} \times \text{Transverse diameter of the body}}{\text{AP diameter of canal} \times \text{inter pedicular distance}}$$

= > 1.4 indicates lumbar canal stenosis

4. Myelography

It provides evidence of nature of cord, nerve roots and dimension of the vertebral canal and the root outlets.

5. CT Scan and MRI

They are extremely valuable after myelography.



It provides evidence of overall transverse axial dimensions of the canal and the foramina and helps in the better assessment of cord compression.

MRI is the first choice when investigating suspected lesions of the spinal cord.

6. EMG Study

It provides differentiation of root lesions from other plexopathies and thoracic outlet problems.



Management

Medical

1. Rest
2. Analgesics
3. Cervical immobilisation with soft cervical collar (cervical spondylosis)
4. Spinal braces (lumbar canal stenosis)

Cervical collar/spinal braces should be worn for a maximum of two to three weeks. Prolonged passive cervical/lumbar support may lead to muscle weakness and interfere with rehabilitation.

Surgical

Indications

1. Failure of medical treatment
2. Objective signs of root lesion or cord lesion.

Procedure: Decompression by laminectomy

Lumbar Disc Prolapse

The patient is usually an adult between 20 and 40 years of age. The commonest site of lumbar disc prolapse is L4- L5.

Symptoms

Low back ache

Acute back ache is severe with the spine held rigid by muscle spasm and any movement at the spine is painful.

Chronic back ache is dull and diffuse usually made worse by exertion, forward bending, sitting or standing in one position for a long time.

Sciatic pain

- The pain radiates to the gluteal region, back of the thigh and leg.
- In S1 root compression, pain radiates to the posterolateral calf and heel.
- In L5 root compression, pain radiates to anterolateral aspect of the leg and ankle.

Femoral root pain:

In a disc prolapse at a higher level L2-L3 pain radiates to the front of thigh.

Tests for Nerve Root Compression

Tests for Sciatic Nerve Root (L5-S1) (Fig. 8.124)

Straight leg raising Test: (SLR)

Raise the affected leg with the knee in extended position (while preventing knee flexion on the normal side), pain at 40° or less denotes positivity and it is suggestive of root compression.

Bragaard Test

Gentle dorsiflexion of the ankle precipitates further tension to the nerve root on reaching the limit in straight leg raising test.

Lasegue Test

First the thigh is lifted to 90° with the knee bent. The knee is then gradually extended. If the nerve sheath is pressed, patient will experience pain in the back of the thigh or leg and the pain radiates to the back.

Bowstring Sign

After performing the Lasegue's test, apply firm pressure with the thumb over the posterior tibial nerve in the middle of the popliteal fossa and over the hamstring tendon. Now, the posterior tibial nerve is stretched like

Neurological Deficit in Disc Prolapse

Level	Nerve root	Motor weakness	Sensory loss	Reflexes
L5-S1	S1 root	Weakness of plantar flexors of the foot	Over lateral side of the foot	Ankle jerk absent
L4-L5	L5 root	Weakness of EHL and dorsiflexors of the foot	Over dorsum of the foot and lateral side of the leg	Ankle jerk normal
L3-L4	L4 root	Weakness of extension of the knee	Over the great toe and medial side of the leg	Knee jerk absent



Stage 1- Straight leg raising test



Stage 2- Dorsiflexion of ankle (Bragaard test)



Lasegue test Stage 1- Flex the hip with knee flexed



Stage 2- Extend knee, look for Lasegue sign



Stage 3- Press with thumb (Bowstring's sign)



Negative response → Flip test ← Positive response - on extending the knee the patient flips backwards due to tension on the nerve root

Fig. 8.124: Stretch test—sciatic nerve roots



Fig. 8.125: Stretch test—femoral nerve roots

a bowstring across the popliteal fossa causing pain locally and radiation to the back.

Flip Test

The patient is seated on the edge of the couch with the hips and knees flexed to 90 degrees. Gently extend the knee. When there is root irritation, the patient will 'flip' backwards to relieve the tension on the nerve root. In the absence of root compression, full extension of the knee is possible.

Test for Femoral Nerve Root (L2-L3-L4) (Fig. 8.125)

Femoral Nerve Stretch Test

In prone position, femoral roots are slack and there is no pain. Tighten the femoral roots by flexion of the knee which causes pain in the back. If there is no pain femoral roots are further stretched by extension of the hip. This test is positive when the femoral roots are compressed.



Management

Conservative Treatment

1. Absolute rest
2. Drugs—Analgesics and muscle relaxants
3. Physiotherapy
4. Lumbar traction
5. Trans-cutaneous electrical nerve stimulation.

Surgical Treatment

Indications:

- Failure of conservative treatment
- Central disc prolapse with neurological deficit
- Recurrent disc prolapse
- Bladder/bowel involvement
- Acute disc prolapse with excruciating pain – not relieved by drugs.

Operative procedures:

1. *Fenestration*: The ligamentum flavum bridging the two adjacent laminae is excised and the spinal cord is exposed.

2. *Laminotomy*: In addition to fenestration, a hole is made in the lamina.
3. *Hemilaminectomy*: The whole of the lamina one side is removed.
4. *Laminectomy*: The laminae on both sides are removed.

Paraplegia

Paraplegia means weakness or paralysis of the lower limbs, sparing the upper limbs. It can occur in disorders of the cerebrum, spinal cord, spinal roots, peripheral nerves or muscles.

I. Intracranial Causes

1. Trauma : Parasagittal region
2. Tumour : Parasagittal meningioma
3. Thrombosis
 - a. Arterial
 - i. Unpaired anterior cerebral artery
 - ii. Bilateral anterior cerebral artery
 - b. Venous
 - i. Sagittal sinus thrombosis

True cortical lesion may cause flaccid paraplegia with bladder involvement and there may be difficulty in differentiating it from LMN type of paraplegia.

The following features help in differentiating from LMN lesions

1. Cortical sensory loss
2. Jacksonian fits

However, spastic weakness can occur due to involvement of descending pyramidal fibres in subcortical regions.

Cerebral Palsy (Cerebral Diplegia)

Cerebral palsy may result in tetraplegia where the degree of involvement is more in the lower limbs than the upper limbs.



Causes

1. Birth injuries
2. Cerebral anoxia



3. Faulty myelination
4. Maternal infection.



Clinical Features

1. It is present from childhood
2. Lower limbs are affected more than upper limbs
3. The limbs are clumsy
4. UMN signs (stiffness of muscle, DTR, scissor gait, Babinski's sign)
5. Early bladder involvement is present
6. It presents with delayed motor development with or without cognitive dysfunction
7. Other features are:
 - a. Cerebellar ataxia
 - b. Speech disturbance
 - c. Convulsions.



II. Spinal Causes

It may be acute or chronic.

Acute Causes

1. Fracture dislocation
2. Vascular
 - a. Endarteritis (TB, syphilis)
 - b. Thrombosis of anterior spinal artery
3. Haematomyelia (AVM, angioma)
More common at or below mid-dorsal level.
4. Epidural abscess
5. Necrotising myelitis.

Acute Transverse Myelitis



Clinical Features (Fig. 8.126)

It is of acute onset with total transection of cord. At times it may evolve over a period of several days to weeks.

1. Back pain or root pain may or may not be present
2. Motor loss (total) } below the level
3. Sensory loss (all modalities) } of lesion
4. Bladder involvement
5. The most common site is mid thoracic region
6. 70% of patient recover within 3 months

Devic's Disease (Neuromyelitis Optica)

A form of transverse myelitis with demyelination of both optic nerve and optic chiasma. The optic nerve involvement may precede or follow the transverse myelitis (Fig. 8.127).



Fig. 8.126: Transverse myelitis



Causes of Pure Spastic Paraplegia

1. Motor neuron disease
2. Erb's paraplegia
3. Hereditary spastic paraplegia
4. Lathyrism
5. Fluorosis.

Compressive Myelopathy

Mechanism of Cord Involvement

1. Pressure effect
2. Ischaemia (arterial)
3. Congestion (veins)
4. Interruption of CSF flow (Froin's syndrome).

Mode of Compression

In general, slow spinal compression affects the pyramidal tract first, the posterior column next, and the spinothalamic tract last. In compression at cervical region, the order of involvement is first ipsilateral upper limb, and ipsilateral lower limb and then lower limb of contralateral side and finally contralateral side of upper limb. This is known as Elseberg phenomenon.

Effects of the Lesion

1. Anterior horn cell: LMN signs (wasting, weakness and fasciculations)
2. Posterior root: root pain or girdle pain (trunk)



Demyelination in spinal cord



Right optic involvement seen as loss of central low intensity signal

Fig. 8.127: Devic's disease

3. Posterior column: Lhermitte's sign (unpleasant sensation) Constriction band around the trunk
4. Pyramidal system: UMN signs (stiffness and spasticity).

In compressive lesions, the involvement of diaphragm is rare due to partial involvement and in traumatic conditions, it is common.

However, these fine differentiating features do not hold true at all times in all cases of compressive myelopathy.

Localisation of Spinal Cord Lesions at Different Segmental Levels

Foramen Magnum

The clinical features depend upon the position and size of the tumour.

- a. Atrophy of sternomastoid muscle
- b. Downbeat nystagmus
- c. C₂ sensory loss and cerebellar signs
- d. Horner's syndrome
- e. Lower cranial nerve palsy

Cervicomedullary Junction

Hemiplegia Cruciate

The paresis or paralysis of ipsilateral lower limb and contralateral upper limb. This is due to arm fibres crossing before the leg fibres at the lower part of the medulla and this is the reason for hemiplegia cruciate.

C₂ Segment Level

Suboccipital pain or sensory loss; descending tract of V nerve (pain and temperature loss over the face) exaggerated trapezius reflex.

C₃ Segment Level

Loss of trapezius reflex.

C₅ Segment Level

1. Inverted biceps jerk
2. Inverted brachioradialis jerk (supinator jerk)
3. Sensory loss over deltoid.

C₆ Segment Level

The loss or diminished biceps and supinator reflexes with exaggerated finger flexor reflex.

C₇ Segment Level

1. Paresis of flexors and extensors of the wrist and fingers
2. Preservation of biceps and supinator reflexes
3. Exaggerated finger flexor reflexes
4. Inverted triceps reflex.

C₈ and T₁ Segment Level

1. Weakness and wasting of the small muscles of the hand
2. UMN signs in the lower limb
3. Uni or bilateral Horner's syndrome.

Thoracic Segments

1. Girdle pain or paraesthesia
2. Segmental LMN involvement (very difficult to make out clinically)
3. Autonomic nervous system dysfunction.

T₃ Segment Level

Sensory impairment in axilla.



Differentiation between Intramedullary and Extramedullary Lesions of the Cord

Features	Extramedullary	Intramedullary
<i>Motor system</i>		
1. Upper motor neuron sign	Common and persist	Less common
i. Spasticity		
ii. Muscle spasm		
2. Lower motor neuron signs		
i. Muscle atrophy	One or two segments at the site of root compression	Wide due to anterior horn involvement
ii. Trophic changes of the skin	Not common	Present
iii. Fasciculation	Rare	Common
<i>Sensory system</i>		
1. Root pain	Common	Rare
2. *Funicular pain	Not present	Present
3. Dysesthesias and paresthesias	Rare	Common
4. Dissociated sensory loss	Absent	Present
5. Sacral sensation	Lost	Sacral sparing for pain and temperature
6. Joint position sense	Lost	Spared
7. Lhermitte's sign	Present	Absent
<i>Autonomic nervous system</i>		
Bowel and bladder disturbances	Late	Early
<i>Investigations</i>		
1. X-ray of the spine	Bony changes may be seen	Not seen
2. Effect of lumbar puncture	Signs and symptoms are precipitated or increased	No such effect
3. Alteration in CSF	Frequently present	Absent
4. Manometry changes (Queckenstedt's)	Early change	Late change
*Funicular pain—Diffuse, burning pain		

Differentiation between Intradural and Extradural Lesions of the Cord

Features	Intradural	Extradural
1. Mode of onset	Asymmetrical	Symmetrical
2. Vertebral pain (Local tenderness)	Not common	Common
3. Nature	Benign	Malignant
4. Symptoms	Long duration	Short duration

T₄ Segment Level

Sensory impairment below the level of nipple.

T₆ Segment Level

The abdominal reflex is impaired or lost (in all quadrants).

T₁₀ Segment Level

Positive Beevor's sign (intact upper abdominal reflexes and absent lower abdominal reflexes with pull of umbilicus more than 3 cm on raising the head).

T₁₂ Segment Level

Abdominal reflex preserved.

L₁ Segment Level

1. The sensory loss in the lower limbs starts from the level of groin.
2. Brisk ankle and knee jerks
3. Absence of cremasteric reflex.

Features	Conus medullaris (S ₃ S ₄ S ₅ and coccygeal)	Cauda equina
1. Onset	Symmetrical	Asymmetrical
2. Dissociated sensory loss	Present	Not present
3. Root pain	Rare	Common
4. Fasciculation	Rare	Common
5. Decubitus ulcer	Rare	Common
6. Bladder and bowel	Early	Early or late depending on root involvement

Features	Conus medullaris (S ₃ S ₄ S ₅ and coccygeal) Pure conus	Epiconus (L ₄ L ₅ S ₁ S ₂)
Bladder involvement	distension	–
Faecal incontinence	present	not present
Saddle anaesthesia	present	not present
Motor symptoms	absent	paralysis of muscles of lower limb

However, it may be difficult to clinically distinguish lesions confined to each of these fine anatomical divisions, and there may be an overlap of signs of conus and epiconus producing extensor plantar reponse (Figs 8.128 and 8.129).

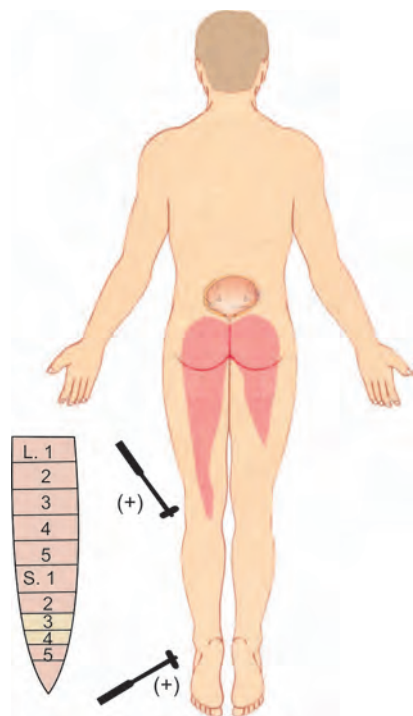
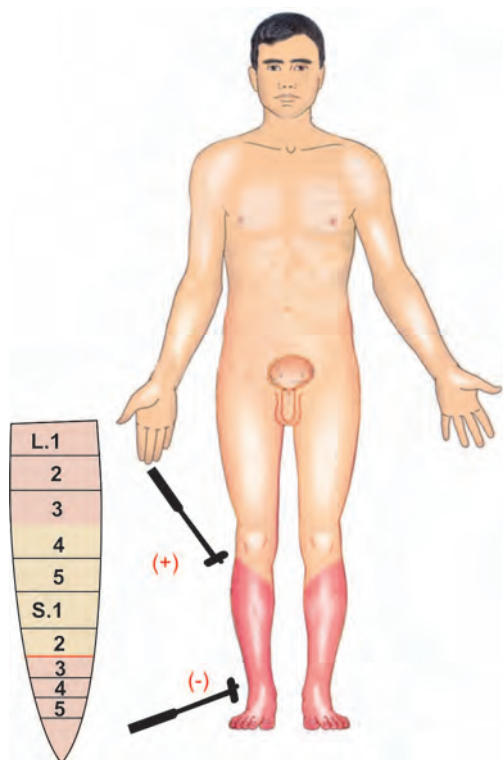
Fig. 8.128: Conus lesion (S_3, S_4)Fig. 8.129: Epiconus lesion (L_4-S_2)

Most Common Causes of Paraplegia

1. Trauma
2. Tumour
3. Tuberculosis
4. Thrombosis
5. Transverse myelitis.

Paraplegia in Flexion and Paraplegia in Extension

Muscle tone is maintained by spinal reflex arc, extrapyramidal system, corticospinal tract and cerebellum. The final modulation is controlled by intact corticospinal tract. When corticospinal tract alone is affected, the extrapyramidal system (especially reticulospinal tract) takes the upper hand, resulting in increased tone of antigravity muscles (paraplegia in extension). When the influence of the extrapyramidal system is cut off, the spinal arc takes over and there is a relative increase in tone of the flexors (hamstring and ilio-psoas) more than the extensors (paraplegia in flexion).

Features	Paraplegia in extension	Paraplegia in flexion
1. Mode of transection	Incomplete transection (only corticospinal tract involved)	Complete transection (affects both corticospinal and extra-pyramidal)
2. Evolution	Early	Late
3. Flexor withdrawal reflex	Not present	Present
4. Mass reflex	Not present	Present
		Any stimulus below the level of lesion produces
		a. Flexor spasm
		b. Emptying of the bladder and bowel
		c. Seminal emission

Persistent Flaccid Paraplegia in UMN Lesions

1. Urinary tract infection
2. Malnutrition
3. Bed sore
4. Stress and strain.

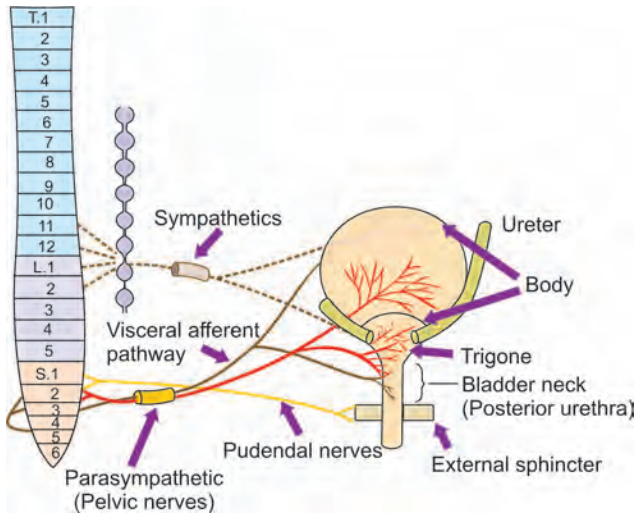

Fig. 8.130: Urinary bladder and its innervation

Bladder Innervation

Pattern of Innervation (Fig. 8.130)

1. Parasympathetic—S₂ S₃ S₄ segments
2. Sympathetic—thoraco-lumbar outflow (T₁₁ T₁₂ L₁ L₂ segments)
3. Somatic—pudendal nerve from S₂ S₃ S₄.

Motor

1. Detrusor muscle—parasympathetic S₂-S₄ through pelvic nerve.
2. Trigone muscle—sympathetic T₁₁-L₂ segments through presacral and hypogastric nerves.
3. External sphincter and perineal muscle—pudendal nerve.

Sympathetic system involvement results in retrograde ejaculation of semen into bladder (infertility). Bladder function is predominantly maintained by parasympathetic system. The parasympathetic system dysfunction leads to the following types of bladder.

1. Incomplete Spastic or Uninhibited Bladder (Cortical Bladder)

Cortical lesions

- a. Post-central—Loss of awareness of bladder fullness, incontinence
- b. Precentral—Difficulty in initiating micturition
- c. Frontal—Inappropriate micturition, loss of social control (It is akin to infant's bladder—frequent voiding at every 100 cc and no residual urine).

2. Complete Spastic or Reflex Bladder or Automatic Bladder or Hypertonic Bladder

Lesions in the spinal segments above S₂ S₃ S₄.

3. Autonomous Bladder or Hypotonic

Lesions at S₂ S₃ S₄ and cauda equina.

4. Sensory Paralytic Bladder (Afferent pathway)

- Impairment of afferent pathways innervating the bladder
- Common causes
 - Diabetes mellitus
 - Syringomyelia
 - Tabes dorsalis
- Intact voluntary initiation of micturition
- Urinary retention-Overflow incontinence
- Frequent urinary tract infection

5. Motor Paralytic Bladder (Efferent pathway)

- Lesions involving efferent motor fibres innervating detrusor
- Lumbar canal stenosis
- Lumbo-sacral meningo-myelocele
- Complication following-Radical hysterectomy, Abdomino-perineal resection
- Painful urinary retention

In cauda equina lesion and in tabes dorsalis, the bladder is more atonic and accepts a very large volume of urine (atonic bladder).

In compressive myelopathy, paraplegia in flexion denotes dense lesion. In transverse myelitis, paraplegia in flexion is an early sign of recovery.

Myelogram Appearance (Figs 8.131 and 8.132)

1. Extramedullary
 - a. Extradural—Brush border appearance
 - b. Intradural—Meniscus sign
2. Intramedullary
 - a. Obliteration of subarachnoid space
 - b. Enlargement of cord.
3. Arachnoiditis
 - Candle guttering appearance (multiple areas of patchy deposits).

Syringomyelia

It is defined as a chronic progressive degenerative disorder of spinal cord characterised clinically by



Fig. 8.131: Myelogram—extradural obstruction at D₁₀ level

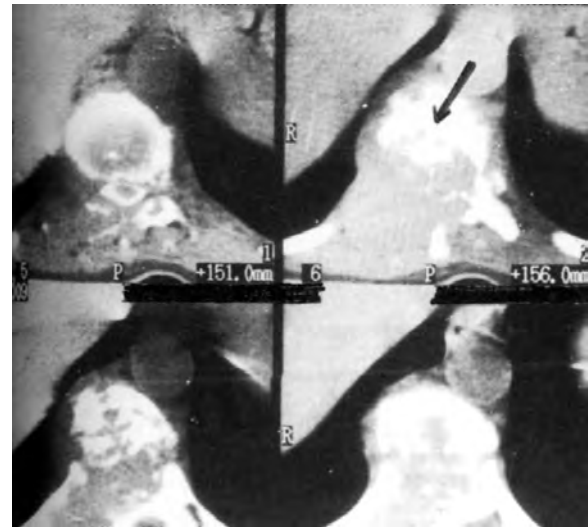

Fig. 8.132: CT dorsal spine—destruction of vertebra due to secondaries

Drug Therapy in Bladder Dysfunction

Drugs	Indications	Mechanism of action
Bethanechol 25-50 mg QID	Retention without obstruction as in neurogenic bladder or postoperative -Facilitates emptying	Stimulation of parasympathetic nervous system – detrusor contraction
Prazosin 1-2 mg BID/TID Terazosin 1-4 mg Doxazosin 1-4 mg	Outlet obstruction as in benign prostatic hypertrophy or bladder neck obstruction/dysfunction	α_1 blockade of external sphincter
Hyoscyamine 0.125 mg HS or 0.25 mg TID Imipramine 25-100 mg HS	Urge incontinence	Relaxes detrusor and increases internal sphincter tone
Oxybutynin 5 mg TID/QID Tolterodine tartarate (Detrol/Detrositol) 2 mg TID/QID	Urinary incontinence, Increased frequency and urgency as a result of neurogenic or overactive bladder	Anticholinergics and direct antispasmodics cause relaxation of detrusor, Muscarinic receptor antagonist -relaxes detrusor and increases internal sphincter tone

brachial amyotrophy and segmental sensory loss of dissociated type (loss of pain and temperature with retained touch) and pathologically by cavitation of central part of spinal cord usually in the cervical region but extends upwards into medulla oblongata and pons (syringobulbia) or downwards into thoracic or lumbosacral segments.

Associated Abnormalities (Fig. 8.133)

1. Thoracic scoliosis
2. Fusion of vertebra (Klippel-Feil anomaly)
3. Platybasia and basilar invagination
4. Arnold-Chiari malformation
5. Intramedullary tumour
6. Traumatic necrosis of cord.

Barnett's Classification

Type I: Syringomyelia with obstruction of foramen magnum and dilatation of central canal.

- a. With type I Chiari malformation
- b. With other causes of obstructive lesions of the foramen magnum

Type II: Syringomyelia without obstruction (idiopathic type) of foramen magnum

Type III: Syringomyelia with other diseases of spinal-cord

- a. Spinal cord tumours
- b. Traumatic myelopathy
- c. Spinal arachnoiditis, pachymeningitis

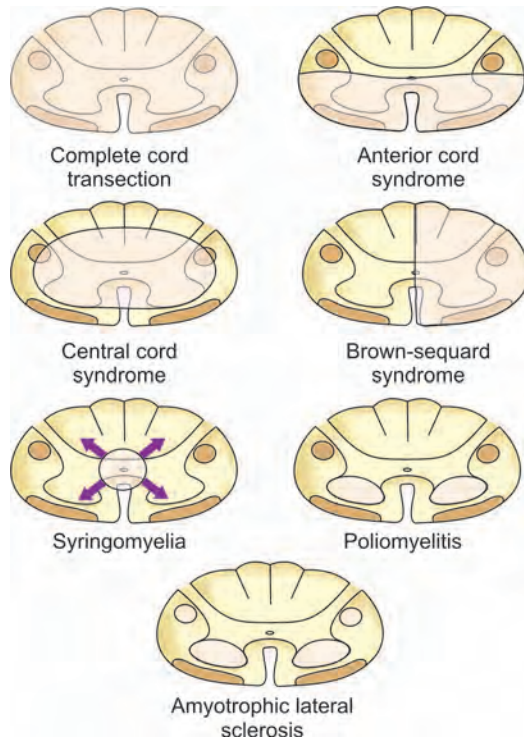

Fig. 8.133: Spinal cord syndrome

Type IV: Pure hydromyelia with or without hydrocephalus.



Clinical Features

The cardinal symptoms and signs are wasting and weakness of the hands and arms, with loss of pain and temperature sensation, with retained touch sensation (dissociated sensory loss) over the trunk and arms, in a classical 'cape' or jacket like distribution.

These features reflect early involvement of the fibres conveying pain and temperature sensation which decussate anteriorly in the cord, and of cervical anterior horn cells. The sensory loss may lead to development of painless burns of the fingers or trophic ulcers.

Horner's syndrome may occur due to involvement of cervical sympathetic chain.

Involvement of the pyramidal tract produces upper motor neuron signs in the lower limbs.

Neuropathic (Charcot's) joints of the shoulder or elbow may develop due to joint sensory loss and therefore increased range of joint movement beyond the normal range (also seen in other conditions like tabes dorsalis, diabetes and leprosy).

Syringobulbia

This may occur when there is an extension of the syrinx into the medulla and may occur in isolation without clinical features of spinal cord involvement.

The usual presentation is sensory loss for pain and temperature over the face, initially involving the peripheral part of the face and gradually extending to the midline, with progression of the lesion, and usually sparing the nose and the mouth (concentric distribution).

The lower cranial nerve involvement results in wasting of the tongue with fibrillation (hypoglossal nerve) and dysphagia and vocal cord paralysis (glossopharyngeal and vagus nerves).



Investigations

1. X-ray of the neck to rule out craniovertebral anomalies
2. CT scan
3. MRI (most sensitive and specific and least invasive) (Fig. 8.134).



Fig. 8.134: MRI spinal cord—syringomyelia



Treatment

There is no medical management.

The main aim of surgery is to promote free flow of CSF through foramen magnum, in order to prevent dilatation of the syrinx or surgical decompression of foramen magnum if there is Chiari malformation. This may relieve pain, and prevent progression of the symptoms. Decompression of the syrinx (syringostomy) can be done at other levels.

Subacute Combined Degeneration (Posterolateral Sclerosis of the Spinal Cord)

Subacute combined degeneration is a neurological complication of vitamin B₁₂ deficiency. The classical neuropathological involvement is symmetrical demyelination with axonal degeneration, primarily involving the posterior and lateral columns of spinal cord (lower cervical and upper thoracic portion of the spinal cord).

Aetiology

Refer causes of Vitamin B₁₂ deficiency in Haematology Chapter.

Symptoms

1. The presenting symptom is tingling sensation in the feet and ascending up the legs and then involving the trunk.
2. The paraesthesia in the fingers is less severe.
3. There is difficulty in walking and unsteadiness of stance and gait which are more pronounced in the dark.
4. In fully developed cases, ataxia and spastic weakness of the legs with profound distal loss of postural and vibration sense with bilateral extensor plantar response are present.
5. Lhermitte's sign is present at the onset and during the course of the disease (sign is due to posterior column involvement).
6. Sphincter disturbance is present only in advanced disease.
7. There is concurrent peripheral neuropathy and it is evidenced by the absence of ankle jerks, impairment of superficial sensations in a glove and stocking distribution and distal weakness of muscles.
8. Mental changes are not uncommon, the changes being mild dementia (impaired memory) to megaloblastic madness.
9. Bilateral optic atrophy may be present in 5% of cases.

Other causes of positive Lhermitte's sign

- a. Multiple sclerosis
- b. Cervical spondylosis
- c. Cervical cord tumour
- d. Radiation myelopathy
- e. Pernicious anaemia
- f. Cisplatin toxicity
- g. Pyridoxine toxicity
- h. Nitrous oxide abuse
- i. Cervical herpes zoster
- j. Tumour of thoracic cord
- k. Tethered spinal cord.



Investigations

Refer Haematology Chapter.



Treatment

Refer Haematology Chapter.

Craniovertebral Junction Anomalies (CVJ)

The craniovertebral junction includes by definition the occipital bone, its opening (foramen magnum) and the atlas and axis vertebrae. The anomalies result from congenital or acquired disorders, especially malrelationship of basiocciput to the atlas, the odontoid process (dens), the body of the axis, and their articular facets along with the respective ligamentous complexes.

Classification

- I. Skeletal anomalies
 1. Platybasia
 2. Basilar invagination—primary or secondary
 3. Occipitalisation of atlas
 4. Klippel-Feil anomaly
 5. Atlanto-axial dislocation (congenital or acquired)
- II. Neuraxial anomalies
 1. Arnold-Chiari malformation

Types of the bladder	Uninhibited contraction	Capacity	Voiding stream	Residual urine	Sensation	
					First desire to void	Perception of fullness
Normal cystometrogram	Absent	450 ml	Normal	Nil	150 ml	450 ml
Uninhibited bladder	Present	165 ml	Normal	Nil	60 ml	160 ml
Spastic bladder	Present	260 ml	Weak to strong but involuntary and interrupted	125 ml	–	Absent
Flaccid bladder	Absent	700 ml	Weak improved by suprapubic pressure	150 ml		Absent



2. Dandy-Walker syndrome, i.e. failure of the foramina of Magendie and Luschka to open
 3. Occipitocervical meningocele
 4. Cysts in the posterior fossa
- III. Combined neural and skeletal anomalies.

1. *Platybasia*

It means an increase in basal angle of the skull. This angle is formed at the intersection of a line drawn from the nasion to the posterior clinoids (or tuberculum sellae or to the centre of the pituitary fossa) on one hand, and with another line from the above point in the plane of clivus to the anterior lip of foramen magnum (Normal—115 to 145°; platybasia > 145°). Platybasia per se is not known to produce any neurological disorder, but it may be associated with basilar invagination.

2. *Basilar Invagination (Basilar Impression)*

The foramen magnum and adjacent skull base are indented or pushed cephalad such that they invaginate the posterior fossa. It is commonly congenital. The acquired causes are secondary to Paget's disease, osteomalacia, hypothyroidism, rickets, hyperparathyroidism, injury and destructive inflammatory or neoplastic disease, achondroplasia and gargoylism.



Clinical Features

- a. It may present at any age.
- b. It may be symptomatic or asymptomatic.
- c. The classical symptoms are occipital headache, hyperalgesia in the distribution of the second cervical nerve roots.
- d. The other symptoms are episodic vertigo, diplopia, drop attacks, dysphagia, dysarthria, dysphonia, ataxia.
- e. Nystagmus, ataxia, intention tremors occur due to cerebellar involvement.
- f. Paralysis of lower cranial nerves and involvement of pyramidal tracts and cerebellum are common.

Diagnosis

Confirmed by radiological studies of CV junction.

3. *Klippel-Feil Anomaly*

It includes congenital fusion of cervical vertebrae. It can involve two segments (congenital block vertebrae) or the entire cervical spine. Congenital cervical fusion is the result of failure of the normal segmentation of the cervical somite.



Fig. 8.135: Short neck



Clinical Features

Feil's triad

- i. Lower posterior hair line
- ii. Short neck (Fig. 8.135)
- iii. Limitations of head and neck movements.

Radiologic Features

Lateral flexion, extension and laminographic views are helpful in evaluating deformity, which shows complete fusion of various cervical vertebrae.

Associated Disorders

1. Scoliosis and/or kyphosis (most frequent anomaly 60%)
2. Urinary tract anomaly (unilateral absence of kidney and/or hydronephrosis)
3. Hearing loss is common (30%) (absence of auditory canal and microtia)
4. Congenital heart disease (4.2 to 14%) (VSD)
5. Synkinesia—20%
6. Sprengel's deformity (25–30%)
7. Facial asymmetry
8. Torticollis
9. Webbing of neck.

4. *Occipitalisation of Atlas (Atlanto-occipital Synostosis)*

It is characterised by partial or complete fusion of the bony ring of atlas to the base of the occiput. In some cases, the anterior arch may fuse with the clivus or the posterior arch may fuse with the squamous occiput.



Clinical Features

Patient may have

- a. Torticollis
- b. Short neck
- c. Low hair line and
- d. Restricted neck movements.

The degree of assimilation can only be confirmed in the frontal (AP) and lateral tomographs of this region.

5. Atlanto-axial Dislocation

Classification

Type I A — Normal odontoid with occipitalisation of atlas

Type I B — Normal odontoid without occipitalisation

Type II — Detachment of odontoid from body of axis or agenesis of part or whole of dens.

In the atlanto-axial joint, the odontoid process (dens) is completely encircled by the anterior arch of atlas ventrally, by the transverse atlantal ligamentous complex dorsally and by the lateral masses of the atlas on either side. In due course of time, the odontoid process almost completely fuses with the body of the axis, thus the dens becomes like a "button in a button hole." Furthermore the ligamentous capsule, around the atlanto-axial joints are relatively loose and thus permit a wide range of lateral and rotational movements like a "wheel around the axle".

It may be congenital or acquired. The acquired causes are:

- a. Trauma
- b. Tuberculosis
- c. Retropharyngeal and para-vertebral infections (children)
- d. Rheumatoid arthritis and ankylosing spondylitis (adults).



Clinical Features

1. H/o sudden worsening after minor injuries that flex the head
2. Tenderness over the atlanto-axial region
3. Restriction of rotation of the head
4. Absence of lower cranial nerve palsies
5. Marked spastic quadriplegia with loss of dorsal column sensations
6. All deep reflexes are exaggerated and the plantar is extensor
7. Absence of hydrocephalus.

Mechanisms by which CV malformation produce neurological symptoms are:

1. Abnormalities of bone and soft tissues may cause a direct pressure on the medulla or upper cervical cord.
2. These may be associated with developmental abnormalities of the central nervous system itself, independent of bony malformation.
3. Bony and spinal cord abnormalities may co-exist.
4. Raised intracranial tension secondary to impaired circulation of the cerebrospinal fluid may itself be responsible for neurological manifestations.

CV junction anomalies can occur at any age and in both sexes. Most of the cases are seen around 20–25 years of age and within 5 years of onset of the symptoms. Most of the cases present with painful or restricted cervical movements, pyramidal signs with varying degrees of motor disability in one or all the limbs, including localised muscular wasting (mostly restricted to hands or the upper limbs). In addition to this, subjective sensory presentations, with or without objective sensory loss, and mild degree of cerebellar incoordination may be present.

Recurrent Transitory Attacks

1. Focal reversible neurological deficit may be present in about 10%.
2. The antecedent history of trivial trauma or fall is present in the majority.
3. The symptoms of cervical cord compression may be present.
4. Focal neurovascular symptoms (vertebral artery involvement) and cranial nerve palsies are rare.

Progressive Medullo-spinal Compressions

1. A febrile illness or history of antecedent injury may lead to the disease
2. Cerebellar signs are predominantly present.

Diagnosis

Radiological

1. Anteroposterior and lateral X-ray of skull.
2. Anteroposterior and lateral X-ray of cervical spine (the latter to be taken in 3 different positions)
 - a. Neutral
 - b. Flexion
 - c. Extension
3. Submento-vertical view of skull
4. Exaggerated Towne's view of skull
5. Open mouth X-ray.



Craniometric Lines in Lateral View

Synonyms	Definition	Normal Measurements	Implications
Wackenheim's line (clivus canal line)	Line drawn along clivus into cervical canal	Odontoid tip is ventral and tangential to this line	Odontoid process transects the line in basilar invagination or forward position of skull
Chamberlain's line (palato-occipital line)	Joins posterior pole of hard palate to opisthion	Tip of dens lies 3.6 mm below this line	Odontoid process bisects the line in basilar invagination
McRae's line (foramen magnum line)	Joins anterior and posterior edges of foramen magnum (basion to opisthion)	Tip of dens does not exceed this line	If effective sagittal canal diameter is less than 20 mm, neurological symptoms occur
McGregor's line (basal line)	Hard palate to lowest point of occipital bone	Tip of dens should not exceed 5 mm above the line	Line position varies with flexion and extension, hence not important
Height index of Klaus	Distance between tip of dens and tuberculum cruciate line	40–41 mm	< 30 mm seen in basilar invagination
Spinolamellar line (spinous interlaminar line)	Line drawn from interoccipital ridge above and down along the fused spinous processes of C ₂ and C ₃	Should intersect posterior arch of atlas	If atlas is fused, posterior arch is anterior to the line; posterior compression of spinal cord may occur



Treatment

It is always surgical.

Peripheral Neuropathy

Peripheral nervous system is a part of nervous system which lie outside the pial structure of spinal cord.

Peripheral neuropathies are conditions with deranged function and structure of motor, sensory, or autonomic neurons or any of the above in combination.

Pathogenesis

It is mainly of two types (demyelination and axonal). But it is usually classified by

- i. Wallerian degeneration
- ii. Axonal
- iii. Primary neuronal (neuronopathy)
- iv. Demyelination (segmental).

An injury to peripheral nerve is classified according to the degree of involvement.

- i. *Neurapraxia*: It is characterised by no structural change of axon and quick recovery within days or weeks (conduction block)
- ii. *Axonotmesis*: It is characterised by loss of axon continuity and slow recovery (months and years)
- iii. *Neurotmesis*: The injury separates the entire nerve and connective tissues. The recovery is incomplete and poor.

Classification of Peripheral Neuropathy

1. According to the mode of onset and rate of progression
 - a. Acute onset (< 1 week (e.g. GBS))
 - b. Subacute onset (1 week–1 month)
 - c. Chronic onset (> 1 month (CIDP))
 - d. Relapsing (multiple episodes after acute and subacute onset).
2. According to the types of nerve fibres involved
 - a. Motor
 - b. Sensory
 - c. Autonomic
 - d. Mixed
3. According to the size of nerve fibres
 - a. Large (posterior column)
 - b. Small (pain and temperature)
 - c. Mixed
4. According to the distribution
 - a. Proximal
 - b. Distal
 - c. Diffuse
5. According to the clinical pattern of the involvement
 - a. Mononeuropathy
 - b. Mononeuritis multiplex
 - c. Radiculopathy
 - d. Symmetrical sensory motor neuropathy
 - e. Symmetrical sensory neuropathy
 - f. Autonomic neuropathy (DM)
 - g. Secondary to systemic disorders
6. According to the pathology
 - a. Axonal
 - b. Demyelination
 - c. Mixed.



Cranio-metric Lines and Angles in Anteroposterior View

Synonyms	Definition	Normal measurements	Implications
Fishgold's digastric line (biventer line)	Joins the fossae for digastric muscles on undersurface of skull just medial to mastoid process	Dens tip should not project above this line; central axis of dens should be perpendicular to the line	Corresponds to McRae's line on lateral view; may be oblique in unilateral condylar hypoplasia; oblique odontoid suggests paramedian abnormality
Fishgold's bimaxoid line	Line connecting tips of mastoid process	Runs across atlanto-occipital joints; line is 10 mm below digastric line	Odontoid tip may be 10 mm above the line
Schmidt-Fischer angle (angle of axes of atlanto-occipital joints)	Angle of axes of atlanto-occipital joints	124–127 degrees; should be measured in plane of dens on tomography	Angle is wider in condylar hypoplasia

Features	Axonal	Demyelination
Mode of onset	Insidious	Insidious or acute
Pattern of involvement	Glove and stocking distribution	Minimal sensory loss
Motor involvement	Preservation of proximal DTR except ankle jerk	Loss of all DTR
Recovery pattern	It takes months or years	Rapid recovery
Residual deformity	Common	Less
Central involvement	Due to toxic neuropathy	Rare
CSF protein	Normal	Raised
Nerve conduction study	Normal or slightly lowered	Very slow

Symptoms

It may be positive or negative symptoms.

	Positive symptoms	Negative symptoms
<i>Sensory</i>		
Paraesthesia	Tingling; pins and needles	Numbness
Hyperpathia	Painful or unpleasant	Loss of specific sensory modalities (e.g. pain, touch and sensory ataxia associated with loss of position sense)
Allodynia	Sensation from non-noxious stimulation of skin	
Dysaesthesia	Spontaneous painful sensation	
Causalgia	Severe dysaesthetic pain usually associated with ANS disturbance	Loss of sensory discrimination

Neuralgia	Paroxysmal pain, e.g. trigeminal neuralgia	
Motor	Fasciculation, myokymia and hemifacial spasm, muscle cramps neuromyotonia (continuous muscle fibres activity)	Weakness

I. Predominantly Motor

1. GBS
2. Infectious mononucleosis and polyneuritis
3. Hepatitis and polyneuritis
4. Diphtheritic polyneuropathy
5. Porphyria
6. Toxic (triorthocresyl PO₄, thallium, lead and aluminium)
7. Paraneoplastic
8. Vaccinogenic/serogenic
9. Lupus (SLE)
10. Acute panautonomic neuropathy
11. Dapsone
12. Organophosphorous poisoning
13. Hereditary multifocal motor neuropathy with conduction block.

II. Sensory

1. Toxin/drugs (cisplatin, nitrofurantoin, pyridoxine toxicity, vitamin B₁₂, vitamin E deficiency)
2. Systemic
 - a. Sjögren's syndrome
 - b. Paraneoplastic
3. Idiopathic (acute and chronic)



4. Hereditary
5. Metabolic
 - a. Amyloidosis
 - b. Diabetes mellitus
6. Infections
 - a. Leprosy
 - b. Lyme disease
 - c. HIV.

III. Sensorimotor

1. Hereditary motor sensory neuropathy I, II, III
2. Metal poisoning (Gold, Ar, Pb, Hg, Thallium)
3. Industrial chemicals
4. Vitamins (B₁, B₆, B₁₂, E)
5. Vasculopathic neuropathies
6. Systemic
 - a. Chronic renal failure
 - b. Myopathy
 - c. Acromegaly
 - d. Primary biliary cirrhosis
 - e. Hypereosinophilic syndrome
7. *Drugs*: alcohol, amiodarone, cisplatin, dapsone, EMB, INH, lithium, phenytoin, thalidomide, vincristine.

IV. Recurrent or Relapsing Polyneuropathy

- a. GBS
- b. Porphyria
- c. CIDP
- d. Certain forms of mononeuritis multiplex
- e. Beriberi
- f. Refsum's disease.

Subacute Sensorimotor Neuropathy

<i>A. Symmetrical</i>	<i>Asymmetrical (mononeuritis multiplex)</i>
1. Deficiency states (Alcoholism (beriberi) Pellagra, vit B ₁₂ , GI tract disorders)	1. Diabetes
2. Poisoning (Heavy metals: arsenic, lead and mercury)	2. Polyarteritis nodosa (angiopathic neuropathies)
3. Drugs (INH, vincristine, dapsone, chloram- phenicol, phenytoin)	3. Subacute idiopathic polyneuropathies
4. Uraemic (polyneuropathy)	4. Sarcoidosis
	5. Ischaemic neuropathy
	6. Vascular disease

V. Syndrome of Mononeuropathy or Plexopathy

- Brachial plexus neuropathy
- Brachial mononeuropathy
- Lumbosacral plexopathies
- Entrapment neuropathies.

VI. Neuropathies with Autonomic Involvement

1. Acute
 - a. GBS
 - b. Porphyria
 - c. Toxic-vincristine
 - d. Pan-autonomic neuropathy
2. Chronic
 - a. Diabetes
 - b. Amyloidosis
 - c. Paraneoplastic
 - d. HIV neuropathy
 - e. Hereditary sensory and autonomic neuropathies.

VII. Small Fibre Neuropathies (Concerned with pain and temperature)

1. Amyloid neuropathy
2. Diabetes
3. Idiopathic
4. Hereditary-sensory autonomic
5. Fabry's disease
6. Tangier's disease.

VIII. Neuropathy with Pain

1. Diabetic
2. Vasculitic neuropathy
3. Toxic arsenic, thallium
4. Alcoholic
5. HIV related
6. Amyloid
7. Paraneoplastic sensory neuropathy
8. Small fibre neuropathy
9. Fabry's disease.

IX. Entrapment neuropathies

Common sites:

- Median nerve in the carpal tunnel
- Ulnar nerve at the elbow
- Lateral cutaneous nerve of the thigh at the inguinal ligament
- Lateral popliteal nerve at the head of the fibula

Uncommon sites:

- Ulnar nerve at the wrist
- Radial nerve in the arm
- Posterior tibial nerve in the tarsal tunnel
- Lower cord of the brachial plexus by cervical rib or fibrous band

Carpal Tunnel Syndrome

Common causes:

- Premenstrual fluid retention
- Myxoedema

- Pregnancy
- Acromegaly
- Diabetes mellitus
- Rheumatoid arthritis
- Myeloma
- Previous trauma
- Amyloidosis
- Synovitis of flexor tendons
- Dislocated carpal bone – lunate

X. Demyelinating Neuropathy

1. Inflammatory – CIDP
2. Paraproteinaemias
 - Benign paraprotein (IgM, IgG, IgA)
 - Myeloma (IgM, IgG, IgA)
 - Waldenstroms macroglobulinaemia (IgM)
 - POEMS syndrome (IgA or IgG)
(Polyneuropathy, Organomegaly-liver, spleen, lymphnodes, Endocrinopathies, M-protein, Skin changes)
3. Hereditary
 - HMSN (type 1a, 1b, 3 and X-linked)
 - Refsum's disease
 - Globoid cell leukodystrophy
 - Metachromatic leukodystrophy
4. Toxic
 - Amiodarone
 - Suramin
 - Diphtheria
5. Acquired demyelinating neuropathies
 - GBS
 - CIDP
 - Diphtheria
 - Multifocal motor neuropathy with conduction block
 - Paraproteinaemic neuropathy



Investigations

Blood:

- TC, DC, ESR, Urea, Electrolytes, LFT
 Blood sugar-If needed GTT, Serum protein EPP (electrophoresis)
 Auto antibodies- ANA, Anti-ganglioside antibodies, Antineuronal antibodies
 Level of vitamin B₁₂
 DNA analysis – Chromosome 17 duplication (HMSN 1 and HMSN 1A)
 Chromosome 17 deletion – HLPP

Urine:

Bence Jones protein, Porphyrins

CSF analysis:

Nerve conduction studies:

Slowing of motor and sensory conduction velocities
 Moderate in axonal neuropathies
 Severe in demyelinating neuropathies
 Reduced amplitude of sensory action potential – axonal neuropathy
 Conduction block in CIDP, GBS, MMN

Electromyography:

Muscle denervation changes

Sensory Threshold:

Thermal and vibration threshold

Imaging:

X-ray chest for sarcoidosis and malignancy
 Skeletal survey for multiple myeloma
 Screening for malignancy

Autonomic function tests:

When there are symptoms and signs of autonomic neuropathy

Nerve biopsy:

Progressive neuropathy when the cause is not known
 To consider long-term immunotherapy in vasculitis and inflammatory infiltration
 Most frequently biopsied sensory nerves:

- Sural nerve at the ankle
- Superficial peroneal nerve over the dorsum of the foot
- Superficial radial nerve at the wrist.

Guillain-Barré Syndrome

It is an acute diffuse post-infective disease causing generalised paralysis involving spinal roots, peripheral nerves and occasionally cranial nerves, commonly involving VII nerve either unilaterally or bilaterally and lower cranial nerves.

The incidence is 1 in 1 lakh populations.

The age group is between 20 and 50 years in both sexes.

Aetiology/Predisposing Disorders

1. Viral (CMV, HIV, EB, Herpes virus, Mycoplasma pneumonia)
2. Bacterial (*Yersinia*, *Campylobacter*, *Salmonella*)
3. Systemic lupus erythematosus
4. Hodgkin's disease
5. Postvaccinal—rabies vaccine, Influenza vaccine



Clinical Features

Patients have acute onset, ascending LMN type of paralysis of both lower limbs and upper limbs involving proximal group of muscle more than distal group. Later they may have respiratory, pharyngeal and laryngeal involvement and may need a ventilator. Autonomic dysfunction is also common. Patients may also have paresthesias of toes and finger tips.

Weakness of lower limb is more than that of upper limb.

50% has facial diparesis.

The muscles are floppy and the tendon reflexes are absent or sluggish. Bladder involvement is rare.

Clinical Variants

1. *Miller Fisher's syndrome*: Ophthalmoplegia, ataxia and areflexia with little weakness in 5% of cases.
2. Ophthalmoplegia with GQ 1b antibody
3. Bulbar weakness with GM 2 antibody
4. Acute dyspanautonomia.



Investigations

- a. CSF findings are:
 - i. CSF protein (100-1000 mg/dl)
 - ii. Albuminocytologic dissociation.
- b. Abnormal electrophysiological findings (conduction delay).

Diagnostic Criteria (Asbury Criteria) of Typical GBS

1. Progressive weakness of two or more limbs due to neuropathy
2. Areflexia
3. Disease course < 4 weeks
4. Exclusion of other causes (Vasculitis, diphtheria, toxin, porphyria, spinal cord syndrome)

Supportive criteria:

1. Relatively symmetric weakness
2. Mild or absent sensory involvement
3. Facial nerve or other cranial nerve involvement
4. Absence of fever
5. Typical CSF profile (Acellular with increased protein level)
6. Electrophysiological evidence of demyelination

Unusual Features in GBS

1. Normal CSF protein or numerous lymphocytes in CSF (more than 50/mm³)

2. A band sensation or tightness around thorax—Transient sensory level
3. Persistent but diminished DTR
4. Early urinary retention.
5. Babinski sign—without other signs of myelopathy. Persistence of any of two features or reduced sensation below a sharply defined level on the trunk indicates spinal cord disease—transverse myelitis.

Poor Prognostic Factors

1. Age more than 40 years
2. Rapid progression to tetraplegia
3. Delay in initiation of treatment
4. Primary or secondary axonal variant

Treatment of GBS

Early:

1. Frequent recording of vital capacity
2. Monitoring of O₂ saturation
3. Heparin 5000 units SC bid
4. Chest physiotherapy
5. Ryles tube feeding if there is bulbar weakness
6. IV immunoglobulin – 0.4 g/kg/day for 5 days
7. If there is no response to immunoglobulin – consider plasma exchange (Plasma exchange 40- 50 ml/kg – 4 times a week)
8. Prevention of exposure keratitis, venous thrombosis, vigilance for hyponatraemia, and other electrolytes and prompt management of cardiac arrhythmias.

Late:

1. Ventilatory assistance if VC < 24 ml/kg
2. Tracheostomy – for prolonged ventilatory assistance > 14 days
3. Cardiac pacemaker for episodes of bradycardia/ cardiac asystole
4. Physiotherapy
5. Occupational therapy

Chronic Inflammatory Demyelinating Polyneuropathy (CIDP)

It is a slowly progressive, sometimes relapsing, steroid dependent, demyelinating sensorimotor polyneuropathy primarily affecting limbs.

Aetiology

1. It may be preceded by viral infection, vaccination, injection and ingestion of foreign material
2. It may follow cytomegalovirus infection
3. It may be associated with GM₁ antibodies.

Similarities between GBS and CIDP

- Symmetrical polyradiculoneuropathy
- Nerve conduction abnormalities of a demyelinating neuropathy
 - Reduced conduction velocity
 - Partial conduction block in motor nerves
- Pathologically both of them show inflammatory changes.

Features	GBS	CIDP
Mode of onset	Acute	Insidious
Progression	It evolves over period of days or weeks and stationary for several weeks	<ol style="list-style-type: none"> Slow and steady progression or stepwise manner Maximum severity after several months

Pathology

- The demyelination is more pronounced in nerve roots, ganglia, and proximal nerve trunks and peripheral nerve throughout the length.
- The demyelination and remyelination are characteristically seen as a "onion-bulb" appearance in nerve biopsy.



Clinical Features

- It affects all age groups.
- Course:
 - 65% chronic relapsing course
 - 15% chronic progressive course
 - 20% monophasic with subacute onset
- Patients have LMN type of weakness of both upper limbs and lower limbs (more of proximal than distal) with minimal sensory involvement affecting posterior column and spinothalamic tract
- The other features are action tremor, nerve enlargement, papilloedema, impotence, incontinence and Horner's syndrome.

Diagnostic Criteria for CIDP

- Mandatory clinical criteria*
 - Progressive or relapsing muscle weakness for 2 months or longer.
 - Symmetrical proximal and distal weakness in upper and lower limbs.
 - Hypo or areflexia
- Mandatory lab criteria*
 - Nerve conduction study with features of demyelination.
 - CSF protein > 45 mg%, cell count < 10/micro litre

- Sural nerve biopsy with features of demyelination and remyelination including myelinated fibre loss and perivascular inflammation.
- Mandatory exclusion criteria*
 - Evidence of relevant systemic disease or toxic exposure.
 - Family history of neuropathy.
 - Nerve biopsy findings incompatible with diagnosis.
 - Diagnostic categories*
 - Definitive: Mandatory inclusion and exclusion criteria and all lab criteria.
 - Probable: Mandatory inclusion and exclusion criteria and 2 lab criteria.
 - Possible: Mandatory inclusion and exclusion criteria and 1 lab criteria.



Investigations

- In agarose gel electrophoresis, a single band is seen in the Ig region
- Electrophysiological study*: Motor conduction velocity is reduced
- Nerve biopsy*: It shows demyelination and remyelination (onion bulb appearance).



Treatment

- Prednisolone 40 to 60 mg for 8 weeks or until improvement occurs and slowly tapered (10 mg/month). If there is no improvement with steroids for 2 months, it can be discontinued
- Plasma exchange*: It is the first line of therapy in respiratory embarrassment
- High dose of intravenous human immunoglobulin
- If no improvement with steroid or plasma exchange, try with immunosuppressive agents. Azathioprine, methotrexate, cyclosporine and cyclophosphamide have been used.

Hereditary Sensory Motor Neuropathy (Charcot-Marie Tooth Disease)

The classical features of this polyneuropathy are genetic transmission, symmetric involvement, slow progression, degeneration of functionally related systems of fibres and axon-myelin fibre loss. It is one of the most commonly inherited peripheral neuropathy. These are 4 types.

HMSN Type 1

- Autosomal dominant inheritance, recessive forms also occur.



2. Most common type.
3. Starts in first or second decade.
4. Presenting symptoms is foot deformity and weakness.
5. Pes cavus and hammer toes in 75%, kyphosis in 10%.
6. Ankle jerk absent universally and total areflexia in 50% cases.
7. All modalities of sensations impaired distally.
8. Distal upper limb weakness and small muscle wasting follows lower limb.
9. Palpable nerve thickening in 25%.
10. Pupillary abnormality and extensor plantar occasionally occur.
11. When associated with tremor or ataxia of limbs, it is called Roussy-Levy syndrome.
12. Nerve conduction studies show absent or reduced sensory nerve action potential. Motor nerve conduction velocity is below 40 m/sec.
13. Nerve biopsy shows hypertrophic onion bulb changes.
14. CSF is usually normal.

HMSN Type 2

1. Usually autosomal dominant. Recessive and X-linked dominant forms are also present.
2. Starts later than type 1-second decade or later.
3. Presenting symptoms are same as type 1.
4. Foot and spinal deformities are less frequent.
5. Peripheral nerves not enlarged.
6. Ankle jerks absent in most cases.
7. Sensory symptoms are less prominent.
8. Motor nerve conduction velocity is usually just within normal range.
9. SNAPs are absent or reduced.
10. Nerve biopsy shows axonal loss with little evidence of demyelination.

Differential diagnosis

1. Friedreich's ataxia.
2. CIDP.
3. Paraproteinaemia.

HMSN Type 3 (Dejerine-Sottas Disease)

1. Autosomal recessive disease usually.
2. Begins in infancy or early childhood.
3. Foot and skeletal abnormalities.
4. Delayed motor development.
5. Proximal weakness.
6. Global areflexia.
7. Enlarged peripheral nerves.

8. All modalities of sensation impaired distally.
9. CSF protein is persistently elevated.
10. Motor conduction velocity markedly reduced to often less than 10 m/sec.
11. Onion bulb changes are seen in nerve biopsy.

HMSN Type 4 of Dyck (Refsum's Disease)

1. Autosomal recessive disease.
2. Begins in late childhood or adolescence.
3. Progressive sensory motor demyelinating polyneuropathy.
4. Cerebellar ataxia and retinitis pigmentosa.
5. Cardiomyopathy.
6. Nerve deafness.
7. Cataract.
8. Ichthyosis.
9. All modalities of sensations reduced.
10. DTR lost.
11. CSF protein is increased markedly.
12. Nerve biopsy shows hypertrophic onion bulb formation.
13. Diagnosis confirmed by increased phytanic acid in blood (normal < 0.3 mg%).



Causes of Nerve Thickening

1. Leprosy
2. Neurofibromatosis
3. HMSN type I and II
4. Amyloidosis
5. Acromegaly
6. Refsum's disease.

Polymyositis

It is a condition of unknown aetiology in which the skeletal muscle is damaged by a nonsuppurative inflammatory process dominated by lymphocytic infiltration.

Polymyositis is characterised by presence of muscle tenderness and oedema.

Classification

- Group I Idiopathic polymyositis
- Group II Idiopathic dermatomyositis
- Group III Dermatomyositis (polymyositis) associated with neoplasia
- Group IV Childhood dermatomyositis associated with vasculitis
- Group V Polymyositis with collagen vascular disease



Clinical Features

I. Idiopathic Polymyositis

1. It is insidiously progressive over weeks or months
2. The female and male ratio is 2 : 1
3. The ocular muscles are spared
4. The reflexes are disproportionately reduced (carcinoma with polymyositis and polyneuropathy or Eaton-Lambert syndrome should be considered)
5. The other features are dysphagia (25%) and cardiac abnormalities (ECG changes, arrhythmias, CCF secondary to myocarditis)
6. The respiratory symptom is dyspnoea (due to lymphocytic pneumonitis, pulmonary oedema and pulmonary fibrosis).

II. Idiopathic Dermatomyositis

1. The skin changes may precede or follow the muscle syndrome
2. The localised or diffuse erythema; maculopapular eruption
3. Scaling eczematoid dermatitis, exfoliative dermatitis
4. "Heliotrope rash"—butterfly distribution
5. Itching and periorbital oedema
6. Subcutaneous calcification
7. Erythematous rash over the anterior chest—V sign
8. Erythematous rash over the back and shoulders—Shawl sign.

III. Dermatomyositis (Polymyositis) Associated with Neoplasia

1. The malignancy may antedate or postdate the onset of the myositis by up to 2 years.
2. The most common malignancies (ca lung, breast, ovary, GIT and myeloproliferative disorders).

IV. Childhood Dermatomyositis Associated with Vasculitis

It is associated with vasculitis in skin and GIT.

V. Polymyositis with Collagen Vascular Disease

Dysphagia is a common symptom of this group (due to the involvement of the smooth muscle of the distal 1/3 of oesophagus in systemic sclerosis).

It is associated with connective tissue disorder (rheumatoid arthritis, systemic lupus erythematosus, systemic sclerosis, malignancy, sarcoidosis).

Extramuscular Manifestations

1. Systemic symptoms—fever, malaise, weight loss, arthralgia and Raynaud's phenomenon.
2. GI symptoms—Dysphagia, GI ulcerations.
3. Cardiac symptoms—AV conduction defects, tachyarrhythmias, dilated cardiomyopathy, congestive cardiac failure and myocarditis.
4. Pulmonary symptoms—may result from interstitial lung disease and thoracic myopathy.



Investigations

1. *Serum enzymes* (CK, aldolase, AST, LDH and ALT) are increased
2. *ESR* is raised
3. *EMG*: It reveals a markedly increased insertional activity (muscle irritability) together with the typical myopathic triad of motor unit action potentials which are of low amplitude, polyphasic and have an abnormally early recruitment.
4. *Muscle biopsy*: The muscle biopsy reveals inflammatory cell infiltrates, destruction of muscle fibres with a phagocytic reaction, and perivascular (perivenular) inflammatory cell infiltration (hallmark of polymyositis).



Treatment

Step 1: Oral prednisolone 1 mg/kg/day for 3-4 weeks followed by tapering slowly over a period of 10 weeks to 1 mg/kg every alternate day.

Step 2: Immunosuppressive drugs—usually started when the patient fails to respond to glucocorticoids after 3 months of treatment, glucocorticoid resistance, glucocorticoid related side effects, rapidly progressive disease with respiratory failure.

A. Azathioprine 3 mg/kg/day.

B. Methotrexate 7.5 mg weekly for 3 weeks followed by gradual increase up to 25 mg/week.

Step 3: IV 1 g 2 gm/kg divided over 2-5 days per course repeated every 6-8 weeks.

Step 4: Other drugs—Cyclophosphamide, chlorambucil, mycophenolate mofetil.

Muscular Dystrophies

They are a group of hereditary disorders characterised by progressive degeneration of selective group of muscles without involvement of nervous system.



Classification

The 'pure' muscular dystrophies:

1. *X-Linked muscular dystrophy*
 - a. Severe (Duchenne)
 - b. Benign (Becker)
 - c. Benign with acanthocytes (McLeod syndrome)
 - d. Benign with early contractures (Emery-Dreifuss)
 - e. Scapuloperoneal (rare)
2. *Autosomal recessive muscular dystrophy*
 - a. Limb-girdle (usually scapulohumeral, rarely pelvifemoral)
 - b. Distal type
 - c. Childhood type, resembling Duchenne
 - d. Congenital muscular dystrophy
3. *Autosomal dominant muscular dystrophy*
 - a. Facioscapulohumeral
 - b. Scapuloperoneal
 - c. Late-onset proximal (limb-girdle)
 - d. Benign early onset with contractures
 - e. Distal
 - f. Ocular
 - g. Oculopharyngeal.

Duchenne Dystrophy (Fig. 8.136)

1. *Inheritance*: X-linked recessive
2. *Age of onset*: Between 3 and 10 years
3. Proximal muscles of upper limbs and lower limbs are predominantly affected, later involving the diaphragm, neck muscles, extraocular muscles, and



Fig. 8.136: Lumbar lordosis in Duchenne dystrophy

facial muscles. Patients may become bed bound within 1st decade of life.

4. Pseudohypertrophy of the muscle is present (enlargement of calf muscle, quadriceps and deltoids)
5. The associated features are macroglossia, absence of incisor teeth, low (less than 10% of normal) IQ, skeletal atrophy and deformity (long bones become pencil thin and fracture), and cardiac involvement (persistent tachycardia, tall R-waves in the right precordial leads and deep Q-waves in limb leads and left precordial leads).



Investigations

1. The serum CK value is 20 to 100 times the normal
2. EMG—myopathic pattern
3. Muscle biopsy—The dystrophin deficiency is seen (Western blot analysis).



Causes of Death

- Respiratory insufficiency
- Aspiration pneumonia



Treatment

Prednisolone 0.75 mg/kg/day significantly slows the progression of disease up to 3 years.

Becker's Dystrophy

1. *Inheritance*: X-linked recessive
2. *Age of onset*: Between 5 and 25 years
3. The pelvic and pectoral muscles are predominantly affected
4. The patients are unable to walk after about 25 years of onset (benign course)
5. The associated features are cardiac involvement, contractures, skeletal deformity and hypertrophy of the muscles.



Investigations

Same as in Duchenne dystrophy.

Prognosis

The longevity is better than Duchenne dystrophy.

Limb Girdle Muscular Dystrophy

1. *Inheritance*: Autosomal recessive and equally affects both sexes.

2. *The age of onset*: Between 10 and 30 years.
3. Pelvic and shoulder girdle muscles are predominantly affected.
4. Patients notice disability only after 10 to 20 years of onset.
5. The proximal tendon reflexes are absent except ankle jerk.
6. The pseudomuscular hypertrophy is an associated feature (calves and deltoids).
7. The cardiac involvement and mental deficiency are rare.



Investigations

The serum enzymes are raised.

Prognosis

Normal lifespan.

Facio-scapulo-humeral Dystrophy

1. *Inheritance*: Autosomal dominant and equally affects both sexes.
2. The muscles predominantly affected are facial muscles, shoulder girdle muscles and serratus anterior.
3. The biceps and triceps jerks are diminished.
4. Patients may have absent pectoralis and biceps muscles.
5. The progression is slow and disability is less (pseudohypertrophy is rare).
6. Labile HTN, nerve deafness, coat's eye disease (Telangiectasia, exudation, and retinal detachment).



Investigation

The serum enzymes (CK) are raised.

Prognosis

Normal lifespan.

Oculopharyngeal Dystrophy



Clinical Features

1. *Inheritance*: Autosomal dominant.
2. Patients have external ophthalmoplegia. Ptosis and/or dysphagia occur in the 4th to 6th decades.

3. Mild neck and limb weakness can occur.
4. Rarely diplopia but pupil is spared.



Investigations

- a. The serum CK may be 2–3 times normal.
- b. *Biopsy*: The distinct feature is the presence of tubular filaments, of 8.5 nm in diameter within muscle nuclei.



Treatment

- a. Cricopharyngeal myotomy may improve swallowing (does not prevent aspiration)
- b. Eyelid crutches improve vision in patients with ptosis.

Congenital Muscular Dystrophy

It is mostly sporadic (without CNS involvement) and sometimes of autosomal recessive inheritance.

It is due to α_2 laminin deficiency.



Clinical Features

1. It is present at birth or within a few months of life.
2. The signs and symptoms are hypotonia, proximal limb weakness, and joint contractures at the elbows, hips, knees and the ankles (contractures at birth is known as arthrogyposis).

Types

1. *Fukuyama congenital muscular dystrophy*: The features are generalised tonic-clonic seizures and delayed development of both mental and verbal status, microcephaly and enlarged ventricles.
2. *Cerebro-ocular-dysplasia muscular dystrophy*: The features are cataract, retinal dysplasia and hypoplasia of the optic nerve.
3. Walker-Warburg syndrome



Investigation

Serum CK level ranges from normal to 20 times normal.



Treatment

Supportive care.



Congenital Myopathies

1. Central Core Disease

The features are:

1. Inheritance: Autosomal dominant and may be sporadic also
2. Decreased fetal movements and breech presentation
3. Skeletal abnormalities (congenital hip dislocation, scoliosis, pes cavus, and clubbed feet)
4. Hypotonia and delayed motor milestones.



Investigations

1. Serum CK is normal
2. EMG: Myopathic pattern
3. Muscle biopsy shows single or multiple central or eccentric discrete zones (cores) devoid of oxidative enzymes and diminished PAS staining.



Treatment

It is essential because it predisposes to malignant hyperthermia during general anaesthesia.

2. Nemaline Myopathy



Clinical Features

1. *Inheritance*: Autosomal dominant and may be sporadic
2. Severe neonatal hypotonia with respiratory distress are present
3. Patients may have delayed milestones and they have long, narrow facies or head, high arched palate and open mouth appearance due to prognathous jaw
4. The other skeletal abnormalities are pectus excavatum, kyphoscoliosis, pes cavus, and clubbed foot
5. Myocardial involvement is an unusual presentation.



Investigations

1. Serum CK is normal
2. EMG: Myopathic pattern
3. *Muscle biopsy*: The diagnostic features are clusters of small rods or nemaline bodies.

3. Centronuclear Myopathy

It is of X-linked recessive inheritance.

Types

1. Neonatal Form

The clinical features are:

- a. Severe hypotonia and weakness at birth
- b. Respiratory distress
- c. Poor prognosis.

2. Late Infantile-childhood Form

The clinical features are:

- a. Delayed milestones (especially walking)
- b. Ptosis
- c. Ophthalmoplegia
- d. Marfanoid features.

3. Childhood-adult Type

The clinical features are:

- a. Onset: Second or third decade
- b. Sparing of ocular movements
- c. Mild nonprogressive limb weakness
- d. No skeletal abnormalities
- e. Predominantly distal weakness resembling CMT disease.



Investigations

1. Normal or slightly elevated CK level
2. EMG features are:
 - a. Positive sharp waves
 - b. Fibrillation potentials
 - c. Complex and repetitive discharges.
3. *Muscle biopsy*: The features are rows of central nuclei often surrounded by a halo.



Treatment

Supportive care.

Dystrophia Myotonica

1. Inheritance: Autosomal dominant
2. Age of onset: Between 20 and 60 years
3. The predominant muscles affected are temporalis, facial, masseter, sternomastoid ('hatchet face' and 'swan neck') and distal group of muscles (quadriceps and tibialis anterior). Sternomastoid is absent in some cases. Patients may have a transverse smile (due to delayed relaxation)
4. The tendon reflexes are depressed
5. Difficulty in releasing the hand after making 'fist'



6. The patient is unable to walk within 15 to 20 years of onset of the disease
7. The associated features are early frontal baldness, ptosis, gynaecomastia, cardiac involvement (cardiomyopathy and mitral valve prolapse), bronchiectasis, altered oesophageal, bowel and biliary tree motility, testicular atrophy, bone changes, mental defect (dementia), hypersomnia, and abnormalities of serum immunoglobulin
Insulin resistance is not uncommon.
8. Patients have 'phenomenon of anticipation', i.e. the disease occurs much earlier in successive generations
9. Formation of dimple in thenar muscles or tongue or wrist extensors on percussion.



Investigations

1. Serum CK level—normal or mildly elevated
2. EMG—Myopathic pattern
3. Muscle biopsy



Management

1. Phenytoin for myotonia (Other drugs which can be used for myotonia are quinine and procainamide. They should not be used in patients with heart block). Mexiletine is also useful for myotonia.
2. Pace maker for heart blocks.

Prognosis

Poor.

Myotonia Congenita (Thomson's Disease)

1. Inheritance: Autosomal dominant
2. Age of onset: From birth
3. Muscular hypertrophy occurs in the second decade.
4. Athletic ability is poor (due to slowness and stiffness)
5. It is worse in the cold seasons (performance of winter games is not possible)
6. The peculiar features are:
 - a. Formation of dimple in the thenar muscles of the hand and tongue after percussion
 - b. Demonstration of myotonia (difficulty in opening the hand after making 'fist')
7. Patients have normal life expectancy.

Paramyotonia Congenita

1. The myotonia (tonic spasm of muscle) and muscle paralysis occur on exposure to cold

2. It is similar to hyperkalaemic periodic paralysis
3. The responsible gene on chromosome 17q 13.1–13.3 causes a defect of the sodium channel a subunit.

Drugs and Myopathy

1. Drugs causing focal damage or fibrosis
 - a. Intramuscular opiates
 - b. Antibiotics
 - c. Paraldehyde
2. Drugs causing necrosis
 - a. Heroin
 - b. Clofibrate
 - c. Epsilon aminocaproic acid
3. Drugs causing myoglobinuria/rhabdomyolysis
 - a. Heroin
 - b. Methadone
 - c. Amphetamine
 - d. Barbiturates
 - e. Diazepam
 - f. INH
 - g. Carbenoxalone
 - h. Amphotericin B
4. Drugs causing hypokalaemia
 - a. Diuretics
 - b. Carbenoxalone
 - c. Liquorice
 - d. Purgatives
5. Drugs causing inflammation
 - a. Procainamide
 - b. D-penicillamine
 - c. L-dopa
6. Drugs causing subacute or painless proximal myopathy
 - a. Corticosteroid
 - b. Chloroquine
 - c. β -blocker
7. Drugs causing myasthenic syndrome
 - a. D-penicillamine
 - b. Aminoglycoside antibiotic
8. Drugs causing malignant hyperpyrexia
 - a. Suxamethonium
 - b. Halothane
 - c. Cyclopropane
 - d. Enflurane, ketamine.

Inflammatory Muscle Disease

1. Bacterial
 - a. *Clostridium welchii* gas gangrene
 - b. Diphtheria—extraocular myopathy
2. Viral
 - a. Influenza—mimics acute poliomyelitis



- b. Bornholm disease—general myalgia and intercostal tenderness
- 3. Parasite
 - a. *Trichinella spiralis* (trichinosis)—extraocular myopathy
 - b. *Taenia solium* (cysticercosis)—muscle hypertrophy (thigh and deltoid region).

Myasthenia Gravis

Myasthenia gravis is a neuromuscular disorder characterised by weakness and fatigability of skeletal muscles due to decrease in number of Ach receptors at neuromuscular junction due to antibody. It occurs at any age and is more common in young adults. This may be associated with other autoimmune disorders (thymic tumours, thyrotoxicosis, rheumatoid arthritis and disseminated lupus erythematosus).

It is more common in females than males. It has a predilection for extraocular muscles and muscles of mastication, facial, pharyngeal and laryngeal muscles. The respiratory and limb muscles (proximal and asymmetric) may also be affected.

Females – 2nd to 3rd decade.

Males – 4th to 6th decade.

Myasthenia Gravis and Thymoma

1. Thymus gland is the primary source of T-cells and it undergoes atrophy after the age of 12 years.
2. It is hyperplastic and enlarged in 70% of cases of myasthenia gravis.
3. The cells in the hyperplastic follicles are B-cells, plasma cells and T-helper cells.
4. Myoid cells in the thymus sensitise the immune system to the Ach receptor protein.



Clinical Features

1. It is insidious in onset.
2. The exacerbations occur in pregnancy or before menses.
3. The cardinal symptom is abnormal fatigue of the muscle and intensification of symptoms towards the end of the day or following vigorous exercise.
4. The first symptoms are intermittent ptosis or diplopia, but weakness of chewing, swallowing, speaking or of moving the limbs also occur.
5. The muscle groups commonly involved in a decreasing order are bulbar, neck, limb girdle, distal limbs and trunk.
6. The sustained activity of the muscles lead to temporary increase in weakness as evidenced by:
 - a. Sustained upgaze for two minutes leads to increased ptosis. The power of the affected muscle improves after brief rest
 - b. On counting aloud, the patients voice gradually weakens.
7. The other features are normal DTR and normal pupillary response.
8. Mild atrophy of the muscles occur in advanced stage.

Modified Osserman Scale

Class I - Ocular only

Class II - Ocular + generalised symptoms

Class III - Generalised symptoms + myasthenic crisis

Class IV - Acute myasthenic crisis.

Myasthenic Crisis

It is defined as need for assisted ventilation because of myasthenia induced weakness of the muscles of respiration (profound weakness of respiratory muscles demanding ventilatory support).

Diagnosis

1. Antiacetylcholine receptor radioimmunoassay.

Generalised	90% positive
Ocular myasthenia	50% positive
If positive	Definite diagnosis
Negative results	Does not exclude MG.

 Mu SK (Muscle specific tyrosine kinase) is positive in 40% of negative cases.
2. *Tensilon test* (Edrophonium): The edrophonium 2 mg is given initially IV and further 8 mg given a minute later if there are no undesirable side effects.

The positivity of the test is indicated by improvement of the muscle power within 30 seconds and persists for 2 or 3 minutes.

The alternative drug is neostigmine 1.5 mg and the effect lasts for 2 hours. (Atropine is used to counteract the muscarinic effect of neostigmine).
3. *Ice test*: Ptosis improves by more than 2 mm when ice is applied to the (shut) affected eye lid for more than 2 minutes. This test is simple, sensitive, specific and non-invasive. Sensitivity is decreased in patients with complete ptosis.
4. *CT scan—chest*: It detects thymic tumours.
5. *Electrophysiological study* detects neuromuscular disorders.
 - a. Repetitive nerve stimulation—Decremental pattern
 - b. Single fibre EMG—increased variability of interpotential interval.
6. MRI brain in ocular myasthenia gravis is essential to rule out sphenoid wing meningioma.

Treatment

The principles of the treatment are:

- i. To maximise the activity of acetylcholine at the remaining receptors in the neuromuscular junction.
- ii. To limit or abolish the immunological attack on motor end plates.

1. Medical Treatment

Neostigmine	7.5–30 mg (average 15 mg) 4 to 8 times/day
or pyridostigmine	30–180 mg qid (average 60 mg)

Adverse effects

“Cholinergic crisis”

Pallor

Sweating

Nausea, vomiting

Salivation, colicky abdominal pain.

2. Immunological Treatment

- a. *Thymectomy*: The beneficial effects are not immediate but it gives symptomatic relief. It is done in patients under 60 years when the weakness is not restricted to extraocular muscles.

Thymectomy is indicated from puberty to 55 years.

- b. *Steroids*: It is indicated when patients have a poor response to anticholine esterase drugs and who have already undergone thymectomy. The initial dose is 15–25 mg/day and then it is gradually raised to 50–60 mg/day.

Later, it is slowly tapered due to early weakness.

3. Plasma Exchange

It removes the antibody from the blood and provides a marked improvement but lasts for a brief period. It is usually reserved for myasthenic crisis or for preoperative preparation.

4. IV Immunoglobulin

It is an alternative to plasma exchange in the treatment of a severe myasthenia gravis.

5. Azathioprine

Indications

- a. Severe or progressive disease
- b. Patients showing poor response to anticholine-esterase drugs, thymectomy and corticosteroid.

Dose: 2–3 mg/kg/day.

Cyclophosphamide and cyclosporine A have been shown to be effective in refractory cases. Mycophenolate and tacrolimus have also been used.

Curariform medications are absolutely contraindicated in myasthenia gravis.

Prognosis

If thymoma is present, the survival is five years in 30% of cases.

Congenital Myasthenia Gravis

- It is not due to autoimmune aetiology
- It is due to presynaptic nerve terminals or acetylcholine receptor or anticholinesterase
- Early onset in infancy or childhood without acetylcholine antibody confirms diagnosis
- EMG, edrophonium test, and genetic analysis are useful
- Treatment depends upon subtype.

Myasthenic Syndrome (Eaton-Lambert Syndrome)

This syndrome is associated with bronchial small cell carcinoma or rarely with autoimmune disease (pernicious anaemia).

Aetiopathogenesis

The antibody is directed against an antigen that cross-reacts with voltage-gated calcium channels involved in Ach release (it is a presynaptic defect).



Clinical Features

1. The weakness is mostly in the proximal muscles of the limbs and trunk
2. The extraocular muscles and bulbar muscles are rarely affected
3. The power of the muscle is steadily increased if contraction is maintained
4. Tendon reflexes are reduced and show a slight response to edrophonium
5. Autonomic disturbances are present (dry mouth, constipation, impotence).



Investigation

Electrophysiological study: An incremental pattern is seen to repetitive nerve stimulation.



The Differences between Myasthenia Gravis and Eaton-Lambert Syndrome

Features	Myasthenia Gravis	Eaton-Lambert Syndrome
1. Male: Female	2 : 3	1 : 1
2. Site of lesion	Postsynaptic	Presynaptic
3. Associated tumour	Thymic tumour	Oat cell carcinoma of the lung
4. Muscle power after exertion	Worsens	Muscle power may improve after first few contractions of muscle.
5. DTR	Preserved	Diminished or absent
6. Repetitive nerve stimulation	Decremental	Incremental
7. Treatment with neostigmine or pyridostigmine	Marked improvement	Slight improvement
8. Response to guanidine	No effect	Good response
9. Autonomic changes	No changes	Present



Treatment

1. Treatment with neostigmine or pyridostigmine or combination with guanidine is variable
2. 3–4 diaminopyridine (under trial) 25 mg/PO QID
3. Plasmapheresis
4. Immunosuppression (steroid and azathioprine).



Chapter 9

Endocrine and Metabolic Disorders

SYMPTOMS

- LETHARGY/DEPRESSION
- APPETITE/WEIGHT CHANGES
- POLYURIA/POLYDIPSIA
- SKIN CHANGES
- CHANGES IN PIGMENTATION
- CHANGES IN STATURE
- HEAT INTOLERANCE
- CHANGES IN HAIR DISTRIBUTION
- MENSTRUAL DISTURBANCES
- COARSENING OF FEATURES
- PROMINENCE OF EYES
VISUAL DISTURBANCES
- HEADACHE
- THYROID SWELLING/PAIN
- GALACTORRHOEA
- IMPOTENCE
- PALPITATION
- CHANGES IN BOWEL HABITS
- EMOTIONAL DISTURBANCES

SIGNS

- Height/Weight
- Body habitus
- Facial features
- Eyes - Graves' Ophthalmopathy
Visual field changes
- Hoarse voice
- Neck - Thyroid swelling
acanthosis
- Skin - Hair distribution
Dry/Greasy
Thickened/Thinned
Pigmented/Pale
Bruising
Vitiligo
Striae
- Hands - Pigmentation of crease
Palmar erythema
Acromegaly
Nail changes
Tremors
Pulse (rate and regularity)
BP
- Breasts - Galactorrhoea/
Gynaecomastia
- Genitalia - Virilisation
Pubertal development
Testicular volume
- Legs - Proximal myopathy
myxoedema
Diabetic changes
- CNS - Emotional state
Neurological deficits
Fundus

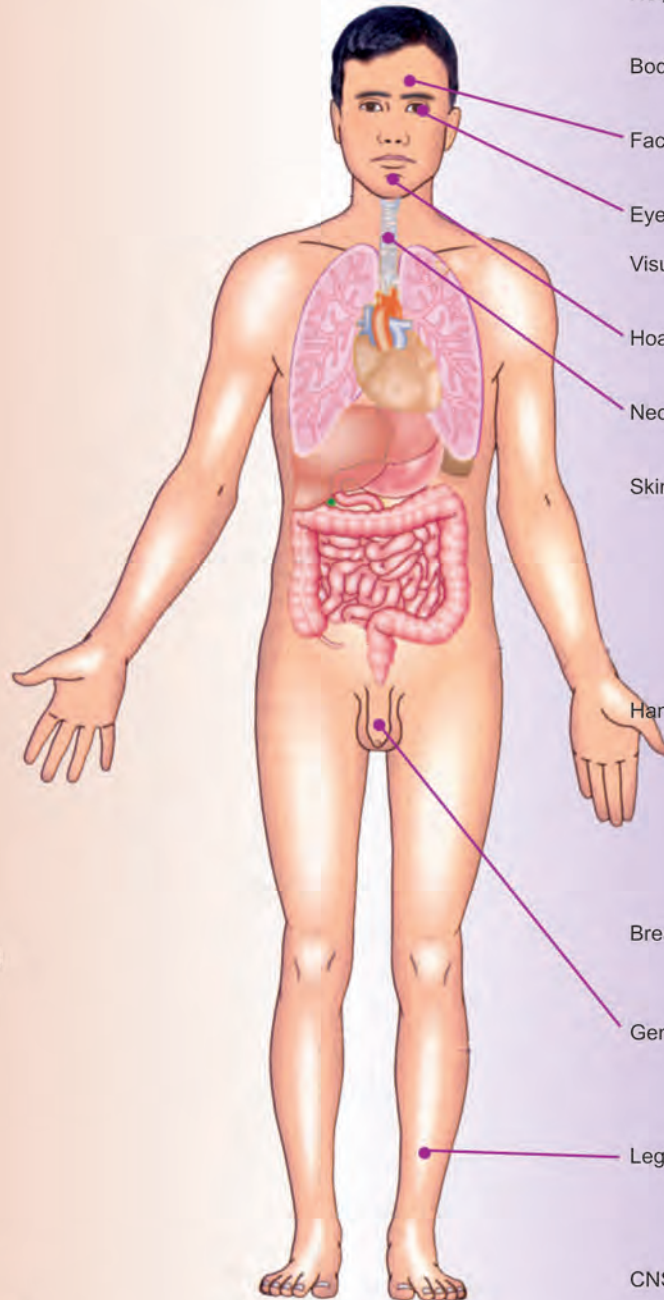

Hypothalamus and Pituitary Gland

Anatomy

The pituitary gland is enclosed in the sella turcica. The gland has two lobes, anterior and posterior and is connected to the hypothalamus by an infundibular stalk which has portal vessels carrying blood from hypothalamus to the anterior lobe and nerve fibres to the neurohypophysis.

Anterior Lobe

Anterior lobe contains three types of cells which are identified by staining reaction.

1. Chromophobe cells (non-secreting)
2. Somatotrophs secrete growth hormone (GH)
3. Mammotrophs secrete prolactin (PRL)
4. Corticotrophs secrete ACTH
5. Thyrotrophs secrete TSH
6. Gonadotrophs secrete FSH/LH.

A group of growth hormone producing cell population is capable of producing PRL. These dual secretors are called mammotrophs. These are transitional cells which can function as either somatotrophs or lactotrophs.

The inhibitor hormones released by hypothalamus are somatostatin (inhibits growth hormone and thyroid stimulating hormone) and dopamine (inhibits prolactin secretion). Somatostatin is an endocrine cyanide.

Clinical Uses of Somatostatin

1. It is useful therapeutically in pancreatic tumours like gastrinomas, insulinomas, glucagonomas, VIPomas and upper GI bleed.
2. It decreases acid secretion in the stomach, gastrin secretion and mesenteric blood flow. It is therefore useful in the treatment of gastric ulcer and variceal bleed.
3. It may also be used in treatment of acute pancreatitis as it decreases exocrine pancreatic secretion.
4. It is used in the treatment of acromegaly as it decreases growth hormone level.

Feedback System

The anterior pituitary hormones (TSH, ACTH, LH and FSH) stimulate the respective target glands to secrete hormones. These hormones in turn exert a negative feedback effect on their respective pituitary cells. In

Hypothalamic hormones	Anterior pituitary hormones
Corticotrophin releasing factor (CRF)	Adrenocorticotrophic hormone (ACTH)
Arginine vasopressin (AVP)	*LPH (β -melanocyte stimulating hormone)
Gonadotrophin releasing hormone (GnRH)	Luteinising hormone (LH)
Growth hormone releasing hormone (GHRH)	Follicle stimulating hormone (FSH)
Growth hormone release inhibitory hormone (GHRH)	Growth hormone (GH)
Thyroid releasing hormone (TRH)	Thyroid stimulating hormone (TSH) Prolactin (PRL)

* β melanocyte stimulating hormone (MSH) amino acid sequence is contained within β lipotrophin (LPH) which in turn is the C-terminal part of the ACTH precursor molecule, pro-opiomelanocortin. The function of LPH is however not definitely known. MSH produces pigmentation of the skin. Of the MSH, LPH and ACTH hormones, ACTH is the most important hormone causing pigmentation.

contrast, PRL and GH have no well-defined end organ hormone secretion that can exert a negative feedback.

Neurohypophysis

The posterior pituitary lobe (neurohypophysis) contain neural fibres which arise from the supraoptic and paraventricular nuclei of the hypothalamus. The hormones secreted by posterior pituitary are vasopressin (ADH) and oxytocin.

Hypopituitarism

Aetiology

This may be due to lesion in the hypothalamus or pituitary.

Hypothalamic Causes

- | | |
|------------|--|
| Congenital | <ul style="list-style-type: none"> • Deficiency of GnRH (*Kallman's syndrome) • Deficiency of TRH • Deficiency of GHRH • Deficiency of CRF |
| Acquired | <ul style="list-style-type: none"> • Tumours (craniopharyngioma, glioma) • Granulomas (sarcoidosis, histiocytosis-X and TB) • Head injury, surgery (stalk section) • Radiotherapy. |

Note: *Kallman's syndrome



- It is inherited as an autosomal dominant, autosomal recessive or sex-linked disorder
- Hypogonadotrophic hypogonadism is present
- Anosmia
- Midline anatomical defects are seen.

Pituitary Causes

- Infarction (Sheehan's syndrome—postpartum)
- Infection (TB, syphilis, fungus, pyogenic, toxoplasmosis)
- Granulomas (sarcoidosis, histiocytosis-X)
- Autoimmune lymphocytic hypophysitis
- Neoplasm (pituitary adenoma, craniopharyngioma and metastatic deposit)
- Haemochromatosis
- Idiopathic and genetic (deficient pituitary hormone production)
- Aneurysm of internal carotid artery.



Clinical Features

This depends upon the underlying relation. If hypothalamus is affected, there may be isolated deficiency of the releasing hormone leading to clinical manifestation that reflects the deficiency.

In lesions of the pituitary gland such as an expanding non-functioning pituitary tumour GH secretion is the earliest to be lost followed by LH, ACTH, and TSH. Loss of GH secretion does not produce obvious symptoms and signs in adults. Decreased LH secretion results in loss of secondary sexual character, loss of libido and impotence in males and amenorrhoea in females. ACTH deficiency causes secondary adrenal insufficiency.

Hormone deficiency	Clinical manifestation
1. GnRH	Delayed puberty, obesity and associated anosmia
2. TRH	Hypothyroidism
3. GHRH	Short stature
4. CRF	Adrenal insufficiency



Investigations

Triple Stimulation Test

1. Measure basal levels of serum T_4 , TSH, oestradiol, testosterone, FSH, LH, PRL, cortisol, glucose, GH.
2. Triple stimulation test is performed by stimulation with injection of
 - a. *Insulin*: Inject insulin IV 0.15 U/kg (0.3 U/kg if acromegaly or Cushing's syndrome is present

or 0.05 U/kg if marked hypopituitarism is present).

- b. *TRH*: Inject 200 µg of TRH IV
 - c. *GnRH*: Inject 50 µg of gonadotrophin-releasing hormone (GnRH) IV.
- Flush the syringe with citrate every time before injecting the other hormone.
3. *Collect blood samples as follows*: FSH, LH, TSH at 20 min and 60 min. GH, cortisol, glucose at 30, 60, 90 and 120 mins.
 4. At the end of procedure, give the patient a good breakfast.

Clinical indications for detailed pituitary stimulation tests:

- To assist in diagnosis of pituitary/hypothalamic disease
- To assess the need for GH replacement
- To determine the feasibility of treating patients with hypothalamic-hypopituitarism with GnRH or GHRH.

Interpretation

Glucose must fall below 40 mg/dl. Normal values are: GH > 20 mU/l, peak cortisol > 550 mmol/l, TSH at 20 min 3.9-30 mU/l, TSH at 60 min, 3.0-24 mU/l. Values lower than these indicate some pituitary deficiency.

Contraindications

Epilepsy, IHD and severe hypopituitarism.

Deficiency	Hormone replacement	Dose
ACTH	Cortisol (hydrocortisone) Cortisone Prednisolone	20 mg 10 AM/ 10 mg 6 PM 25 mg AM/12.5 mg PM 5 mg AM/2.5 mg PM
TRH	L-thyroxine	0.1-0.15 mg/day (single dose orally)
LH, FSH In female (Pre-menopausal)	Cyclical oestrogen therapy with Ethinyl oestradiol	20-30 µg for 3 weeks
Male	Progestogen (medroxy Progesterone acetate) Human chorionic gonadotrophic hormone LH and FSH	5 mg/day from day 14-21 of menstrual cycle 3000 IU IM/week 75 IU 3 times/week
GH	Testosterone (Pergonal) Biosynthetic	250-500 mg IM every 2-4 weeks 24 U/m ² /week subcutaneously
Male	Testosterone transdermal patch	2.5-5 mg daily.
Adult women	Dehydro epiandrosterone	50 mg in AM

Treatment

The principle of management is to prevent and provide adequate substitution of the deficient hormone.

- Hypopituitarism is usually treated by measurement of end organ hormones thyroxine, cortisone, testosterone (male), oestrogen and progesterone (female).
- Pituitary hormones are replaced in only two conditions:
 - a. GH replacement in short statured patients with unfused epiphysis
 - b. Patients desiring fertility
 - c. Prolactin therapy is rarely needed.

Hypersecretory Disorders of Anterior Pituitary

Hyperpituitarism

Acromegaly and Gigantism

Excess of GH secretion, if occurs before fusion of epiphyses of long bones leads to gigantism and if it occurs after fusion of epiphyses leads to acromegaly.

Aetiology of Acromegaly

1. Excess growth hormone secretion
 - Pituitary adenoma
 - Somatotroph adenoma
 - Mixed GH and prolactin-cell adenoma
2. Pituitary carcinoma
3. Ectopic GH – releasing hormone secretion
 - Carcinoid tumour (59%)
 - Pancreatic islet cell tumour (21%)
 - Small cell carcinoma of lung (7%)
 - Adrenal adenoma (3%)
4. Ectopic GH secretion



Clinical Features (Fig. 9.1)

Soft Tissue Changes

- Skin thickening
- Increased sweating (due to enlarged sweat glands or hypermetabolism)
- Enlargement of lips, nose and tongue
- Increased heel pad thickness (Fig. 9.2)
- Arthropathy (Due to bony overgrowth and deformity around large weight-bearing joints)
- Myopathy

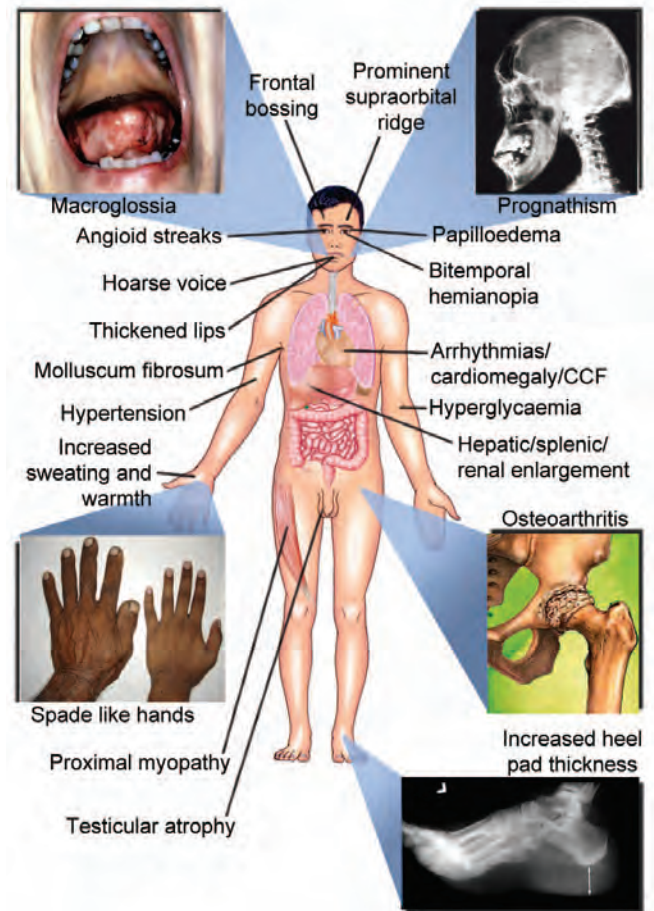

Fig. 9.1: Clinical features in acromegaly



Fig. 9.2: Acromegaly—increased heel pad thickness

- Carpal tunnel syndrome (compression of the median nerve by hypertrophied fibrocartilaginous tissue of the wrist)
- Visceromegaly (e.g. thyroid, heart, liver)
- Sleep apnoea (both central and obstructive)



Fig. 9.3: Acromegaly—spade like fingers and toes

- Galactorrhoea
- Hypertriglyceridemia
- Colonic polyps
- Deepened voice
- Abnormal PFT results.

Acral Enlargement (Fig. 9.3)

- Large hands (difficult to remove rings)
- Large feet (increase in shoe size, increased width).

Other Bone Changes

- Growth of lower jaw—prognathism. Teeth are widely spaced
- Skull growth—prominent supraorbital ridges with large frontal sinuses
- Kyphosis.

Metabolic Defects

- Glucose intolerance (25%)
- Clinical diabetes mellitus (10%)
- Hypertension (25% associated increase in total exchangeable sodium).

CVS – Changes

- Hypertension
- LVH
- Cardiomyopathy
- Arrhythmias

Effects of Tumour Mass

- Headaches
- Visual disturbances – Diplopia, field defect
- Hypopituitarism – decreased libido, erectile dysfunction, menstrual dysfunction.

Long-term Complications

- Atheromatous disease
- Colonic cancer.

Lab Diagnosis

1. The most reliable test involves the assessment of GH responses to oral glucose. In acromegaly, glucose does not suppress growth hormone (GH) and in about 50% of patients there is paradoxical rise. (In normal subjects GH is suppressed to below 2 mU/litre). In 70% of acromegalics, there is a GH rise after TRH administration (this is not found in normal subjects).
2. In the absence of serious concurrent illness, serum levels of IGF-I are uniformly elevated in patients with active acromegaly.
3. Two or three random measurements of serum GH should also be obtained to provide an average pretreatment base line value.
4. Anatomic evaluation of the sellar contents by radiologic examination (CT or MRI scan) and a formal visual field examination (Figs 9.4 to 9.7).

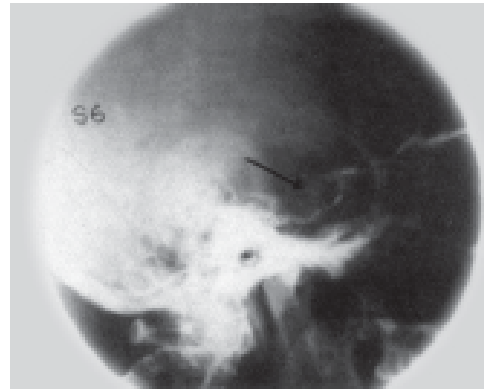

Fig. 9.4: Widened sella turcica

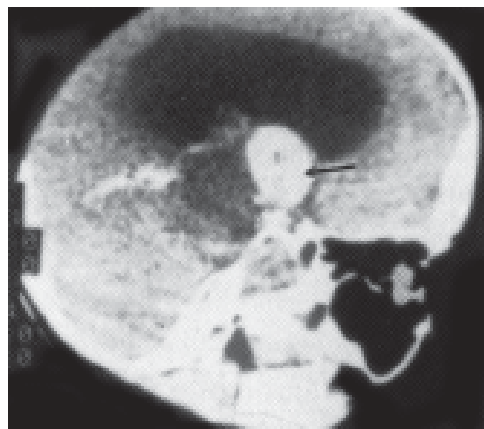

Fig. 9.5: CT-brain sagittal section—pituitary tumour

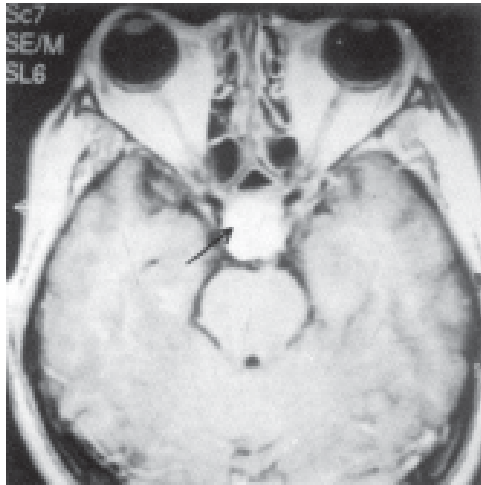

Fig. 9.6: MRI brain—pituitary tumour

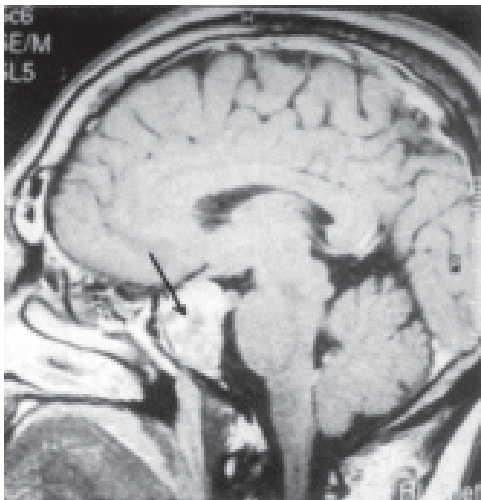

Fig. 9.7: MRI brain sagittal section—pituitary tumour



Treatment

Surgery:

- Transphenoidal surgery is the preferred primary treatment.
- Drugs are adjuvants to surgery in preoperative reduction of tumour size.

Drugs:

1. *Octreotide*: It is a synthetic analogue of somatostatin given in a dose of 50 µg tid and is increased upto 1500 µg/day.

Sandostatin—LAR is a sustained release long acting formulation of octreotide incorporated into microspheres that sustain drug level for several weeks after IM injection 30 mg IM every 6 weeks.

Lanreotide—It is a slow release depot somatostatin preparation that suppresses GH and insulin like growth factor 1 hypersecretion for 10 to 14 days after 30 mg IM injection.

- a. It produces shrinkage of GH producing adenomas
 - b. All symptoms improve except bone changes and osteoarthritis which do not increase but can be stabilised.
2. *Bromocriptine*: The clinical effects of this drug are variable. It is used as an adjunctive therapy following radiation or surgery.
 3. *Pegvisomant* – A new GH antagonist that lowers IGF-1 to normal level in almost all patients. The dose is 10-30 mg SC daily.
 4. Radiation (External radiation therapy or high energy stereotactic techniques are used as adjuvant therapy for acromegaly).

Hyperprolactinaemia

It is the most common biochemical disturbance of pituitary function.



Causes

1. Altered physiologic states
 - Sleep
 - Stress
 - Postprandial, especially in women
 - Coitus
 - Pregnancy, including pseudocyesis
 - Nursing or nipple stimulation
 - Chest wall or spinal cord lesions
 - Hypoglycaemia
 - Hypothyroidism
 - Chronic renal failure
2. Drugs
 - Phenothiazines
 - Butyrophenones (e.g. haloperidol)
 - Reserpine
 - Alpha methyl dopa
 - Opiates
 - Cimetidine
 - Oestrogens.
3. Decreased delivery of prolactin-inhibiting factor to pituitary
 - Stalk section
 - Hypothalamic destruction.
4. Prolactin-secreting pituitary tumours
 - Prolactinoma.



Clinical Features

- In females, it produces amenorrhoea with or without galactorrhoea
- In males, it produces decreased libido and impotence or symptoms due to intracranial mass lesion.
- Galactorrhoea is uncommon in men, because the male breast has not been “primed” with endogenous oestrogen
- Some women with PRL—secreting tumours also manifest hirsutism and elevated serum androgens.

Lab Diagnosis

- Since aetiological factor is multifactorial, careful history will avoid unnecessary investigations.
- Plasma prolactin levels greater than 30-40 ng/ml almost invariably indicate a diagnosis of prolactinoma (upper limit of normal for many assays is < 15-20 ng/ml).
- Three important conditions to be excluded are renal failure, pregnancy and hypothyroidism before investigations.

Plasma prolactin level correlates with the tumour mass size. Small lesions (microadenomas) can give rise to moderate elevation of plasma prolactin levels which can also occur in the other above-mentioned conditions causing hyperprolactinaemia. However, a large sized tumour (macroadenoma) can cause enormous elevation of plasma prolactin levels (> 200 ng/ml).

- Stimulation test is useful to differentiate PRL secreting tumours from other conditions causing hyperprolactinaemia. TRH stimulation test will result in 100% elevation of serum prolactin level over the basal value in patients with hyper PRL due to other causes. The serum prolactin level does not show any significant increase, when hyper PRL is due to PRL secreting tumours.



Treatment

Medical treatment is the treatment of choice.

- Dopamine agonist therapy.
 - Bromocriptine 2.5-15 mg/day 8-12 hourly orally.
 - Cabergoline 250-1000 microgm twice weekly.
 - Quinagolide 50-150 mg/day OD orally.
 - Pergolide mesylate 3 mg daily
 - Lisuride
 - It causes shrinkage of prolactin secreting tumours

- It abolishes galactorrhoea and restores normal reproductive function.
- Surgery and radiotherapy are not usually necessary. Surgery is indicated in the following:
 - Visual field defect persisting despite medical therapy
 - Drug intolerance.
 - Assess plasma prolactin level every 6 months while on therapy and every 2 years on cessation of bromocriptine therapy.
 - 90% of cases of prolactin secreting macroadenomas respond to medical management. Women with prolactin secreting macroadenoma should not become pregnant unless the tumour has been resected (risk of tumour enlargement).
 - Pituitary imaging should be repeated every 3-6 months in cases of prolactin secreting macroadenomas to assess the mass size.

Pituitary Tumours

Nearly all tumours are almost always benign. It contributes to 10% of all intracranial neoplasms.

- Chromophobes* (70%): These usually produce hypopituitarism due to pressure effect. Sometimes it may secrete hormones like PRL, ACTH, or GH.
- Acidophilic* (15%): It may secrete GH and PRL (10%).
- Basophil* (15%): It secretes ACTH (pressure effect is rare).

Pituitary adenomas:

- Microadenomas (< 10 mm in diameter): Clinical manifestation only when they secrete excess hormone. They do not cause mass effect or hypopituitarism.
- Macroadenoma (> 10 mm in diameter). Clinical manifestations can be either hyperpituitarism or hypopituitarism or mass effect (head ache, visual field loss)
- Secretory adenomas produce prolactin, GH or ACTH
- Non-secretory macroadenomas may cause hypopituitarism or mass effects
- Non-secretory microadenomas are common incidental radiographic findings (10% of the normal population) and therapy is not needed.

Secretory Tumours

i. PRL	35%
ii. GH	20%
iii. GH + PRL	7%
iv. ACTH	7%
v. FSH and LH	1%
vi. No hormone	30%



Clinical Features

The clinical features can be due to either pressure effect or hyper- or hyposecretion of pituitary hormones.

The features are hydrocephalus, seizures, erosion of floor of sella leading to CSF rhinorrhoea, headache (dura stretching), bitemporal hemianopia initially starting in the upper field (optic chiasma, optic nerve tract), diplopia and strabismus and lesions of IIIrd, IVth and VIth cranial nerves (cavernous sinus involvement).

Lab Diagnosis

1. *Plain X-rays* (X-ray skull to view the sella—cone view sella)
 - a. It demonstrates the enlargement of sella turcica and erosion of the clinoid processes
 - b. Suprasellar calcification (craniopharyngioma)
 - c. A double floor of the sella.
2. *Computed tomography*: It demonstrates the suprasellar and parasellar anatomy in patients with macroadenoma (more than 10 mm diameter) and microadenoma (less than 10 mm diameter).
3. *Cisternography*: It is usually done in conjunction with CT scanning to demonstrate an empty sella, the superior aspect of a pituitary tumour or a hypothalamic lesion.
4. MRI



Treatment

1. In elderly and terminally ill patients, no active intervention is needed other than end organ hormone replacement or inhibition of hypersecreting tumours.
2. Surgery can be done by the trans-sphenoidal or transfrontal approach.
3. Radiotherapy is useful for small and medium size tumours with pressure effect and also when surgery is contraindicated.

It is a follow-up modality in invasive and incompletely removed tumours. It is contraindicated as a sole therapy in large tumours with major visual defect. Also contraindicated in females with prolactinoma who wish to restore fertility.

Radiotherapy is also contraindicated in acromegaly patients with serum GH levels >50 ng/ml prior to treatment.

4. a. Medical management is the primary modality of treatment for prolactinoma. Pressure effect is also corrected with hormonal therapy.

- b. Medical treatment is an adjunctive therapy in acromegaly and TSH secreting tumours.
 - c. There is no role for medical therapy in non-functioning tumours.
5. Adjunctive treatment with octreotide in GH and TSH secreting tumours may be given.

Pituitary Hyperplasia

It occurs in long-standing primary endocrine end organ failure, as a result of hypersecretion of appropriate trophic hormones. This condition should not be mistaken for pituitary neoplasm. Suppression test is useful to diagnose this condition. Replacement with specific end organ hormone therapy results in gradual regression of pituitary hyperplasia and sella size.

Empty Sella Syndrome

Types

Primary

Empty sella syndrome is due to congenital incomplete diaphragma sella which allows CSF to enter into the sella as an extension of the subarachnoid space. Normal pulsatile CSF pressure then compresses the pituitary and gradually expands the sella turcica. Primary empty sella is most often found in obese, middle-aged women.

This may result in compression of the pituitary stalk and thereby decreased transport of hypothalamic releasing hormones to the anterior pituitary (usual hormone deficiencies are those of gonadotrophic hormone and GH). There is no abnormality in function of the posterior pituitary gland.

Secondary

Empty sella syndrome is found in various pituitary tumours following infarction, ablation, destruction by surgery, radiotherapy, or following shrinkage after medical therapy.



Treatment

1. No treatment other than reassurance (primary)
2. Hormone replacement may be useful in secondary empty sella syndrome of pituitary origin.

Craniopharyngioma

It is a tumour of developmental origin arising from Rathke's pouch. The peak incidence is in the second decade of life.



Craniopharyngiomas are cystic in 60% of cases, solid in 15% of cases and combined cystic and solid in 25% of cases.

The tumour originates above the sella. It causes pressure on the optic chiasma, hypothalamus and pituitary, resulting in increased intracranial pressure, visual defects, endocrine hypofunction (e.g. GH deficiency in children), hyperprolactinaemia and mental deficiency.



Investigations

1. X-ray skull—enlargement or erosion of sella with supra- or intrasellar calcification
2. CT and MRI are useful.



Treatment

1. Surgery
2. Radiation therapy
3. Hormone replacement therapy.

Disorder of the Neurohypophysis

Diabetes Insipidus (DI)

Diabetes insipidus is the excretion of a large amount of dilute urine (hypotonic polyuria).

The criteria to be satisfied in order to establish this diagnosis are:

- a. Polyuria of more than 3 lit/day (more than 50 ml/kg/day)
- b. Urine osmolality less than 300 mOsm/kg
- c. Urine specific gravity less than 1.010.

Aetiology

Diabetes insipidus may result from any one of the three defects:

1. Inadequate secretion of arginine vasopressin (AVP) or antidiuretic hormone (ADH) known as *central*, or *neurogenic DI*.
2. Impaired renal responsiveness to AVP, known as *nephrogenic DI*.
3. Increased water intake of primary polydipsia, known as *dipsogenic DI*.

Central DI



Causes of Central DI

1. Familial (autosomal dominant)
2. Acquired

- a. Idiopathic
- b. Trauma or surgery to the hypothalamus-posterior pituitary region
- c. Tumours (craniopharyngioma, meningioma, metastatic carcinoma, lymphoma, carcinoma of breast and lung)
- d. Infection (encephalitis, meningitis)
- e. Granulomatous disease (sarcoidosis, histiocytosis, Wegener's disease)
- f. Vascular disorders (aneurysm, Sheehan's syndrome, aortocoronary bypass)
- g. Drugs-diphenyl hydantoin and alcohol
- h. Autoimmune-lymphocytic hypophysitis (rare).

Criteria to Diagnose Central DI

- a. Inappropriately dilute urine in the presence of strong osmotic or non-osmotic stimuli for AVP secretion.
- b. Absence of intrinsic renal disease.
- c. A rise in urine osmolality following the administration of AVP.



Clinical Features

Central DI manifests itself clinically when AVP secretory capacity is reduced by more than 75%.

The cardinal symptoms of DI are polyuria, thirst, and polydipsia.

Urine volume varies between a few litres per day in partial DI to 20 litres per day in complete DI, and the onset being abrupt.

The patient has intense thirst and has a preference for cold or iced drinks. If access to water is interrupted, hyperosmolality develops rapidly, and CNS symptoms such as irritability, mental dullness, ataxia, hyperthermia, and coma can develop.

Lab Diagnosis

- a. Large urine volume (usually greater than 3 litres per day)
- b. Urine osmolality less than 300 mOsm/kg
- c. Minimally elevated plasma osmolality of greater than 300 mOsm/kg
- d. Inappropriately low serum AVP levels despite slightly elevated plasma osmolality.



Treatment

Treatment is usually with a long acting analogue of vasopressin (desmopressin or DDAVP). The usual dose is 10-20 µg once or twice daily intranasally. A parenteral and oral form of this drug is also available. Injection

desmopressin: 1-2 mcg qd or bid. Oral desmopressin: 100-400 mcg bid or tid. Other analogues of vasopressin available are lypressin given 2-4 units intranasally or aqueous vasopressin 5-10 units subcutaneously.

Nephrogenic DI

Nephrogenic DI is a polyuric disorder that results from renal insensitivity to the antidiuretic effect of AVP. This disorder is characterised by:

- Presence of normal rates of renal filtration and solute excretion
- Persistently hypotonic urine
- Normal or high levels of AVP
- Failure of exogenous AVP to raise urine osmolality or to reduce urine volume.



Causes of Nephrogenic DI

- Hereditary
 - Autosomal dominant (mutation in aquaporin gene)
 - Autosomal recessive (mutation in aquaporin gene)
 - X-linked
- Acquired
 - Hypercalcaemia, hypokalaemia
 - Vascular (sickle cell trait or disease)
 - After treatment for urinary obstruction
 - Infection (pyelonephritis)
 - Infiltrative (amyloidosis)
 - Drugs (lithium, demeclocycline, methoxyflurane)
 - Low protein diet.



Treatment

The most effective therapy is the combination of thiazide diuretics (5-10 mg/day) and mild salt restriction (increases isotonic proximal tubular fluid absorption and a decrease in the volume of fluids delivered to the collecting duct).

Prostaglandin synthesis inhibitors such as ibuprofen, indomethacin, and aspirin may be used adjunctively to treat this condition (reduce delivery of solutes to the distal tubules, thereby reducing urine volume and increasing urine osmolality).

Chlorpropamide (125-250 mg/day) and carbamazepine (100-200 mg/day) enhance the renal responsiveness to AVP, and may be used to treat this condition.

Dipsogenic DI

Dipsogenic DI is seen when the osmotic threshold for thirst, is paradoxically lower than that for AVP secretion. This reversal of the normal relationship between thirst and AVP secretion results in chronic thirst, polydipsia, and polyuria. The hallmark of primary polydipsia is diluted plasma, diluted urine, and suppressed AVP secretion.

Treatment is focussed on behaviour modification to reduce water intake.

Adipsic Hypernatraemia

This is characterised by chronic or recurrent hypertonic dehydration and deficient AVP response to osmotic stimulation. It is caused by agenesis or destruction of hypothalamic osmoreceptors.

Aetiology

Acquired:

- Vascular—Occlusion of anterior communicating artery.
- Tumours—Craniopharyngioma, meningioma, glioma and metastasis.
- Granulomas—Neurosarcoid and histiocytosis.
- Trauma
- Psychogenic
- Idiopathic
- Others—Hydrocephalus, AIDS, CMV encephalitis

Congenital:

- Microcephaly
- Midline malformations

Genetic: Autosomal recessive.



Clinical Features

Patients have little or no thirst despite their dehydration. There are signs of hypovolemia and muscle weakness, pain, rhabdomyolysis, hyperglycaemia, hyperlipidaemia and ARF may also occur.



Treatment

- Administration of water by mouth if the patient is alert.
- If the patient is obtunded, 0.45% saline IV.
- If diabetes insipidus is present or develops during rehydration, DDAVP should be given.
- Correct hyperglycaemia and electrolyte imbalance.



Tests to Differentiate Central DI, Nephrogenic DI and Dipsogenic DI

1. *Water deprivation test*: This test is done to distinguish between diabetes insipidus and psychogenic polydipsia. It also helps to determine whether diabetes insipidus is of the central or nephrogenic type.

The test is carried out as follows:

- No coffee, tea or smoking on the day of test
- Free fluids until start of test
- Light breakfast
- No fluids for 8 hours after 08.30 a.m
- Weigh patient at start and after 5 and 8 hours
- Stop test if patient loses more than 3% of body weight.

After fluid deprivation for 8 hours, urine and plasma osmolality are measured.

In patients with psychogenic polydipsia there is a rise in urine osmolality > 800 mOsm/kg (as urine is concentrated normally), whereas in patients with diabetes insipidus the urine osmolality remains low (due to failure to concentrate urine normally). The plasma osmolality rises in both conditions.

Having detected the presence of DI, it is now possible to differentiate between central and nephrogenic DI. Exogenous desmopressin $2 \mu\text{g}$ IM or $20 \mu\text{g}$ intranasally is given and then urine is collected hourly for the next 4 hours.

In patients with central DI, the urine osmolality will increase > 800 mOsm/kg. This does not occur in patients with nephrogenic DI, as the exogenous AVP has no action on the renal tubules.

2. *Hypertonic saline infusion test*: A solution of 3% saline is infused to raise serum sodium to 145-150 mEq/litre. Blood samples are obtained for measurements of serum osmolality and plasma AVP levels. Patients with dipsogenic DI and nephrogenic DI exhibit normal stimulation of AVP release in response to the hypertonicity, whereas patients with central DI exhibit little or no rise in plasma AVP levels.

3. MRI – T₁W image of hypothalamus and pituitary. No bright spots – pituitary or nephrogenic DI. Presence of bright spots – Dipsogenic DI.

Syndrome of Inappropriate Antidiuretic Hormone Secretion (SIADH)

SIADH is characterised by hyponatraemia and submaximal urinary dilution caused by a sustained

release of AVP in the absence of osmotic and non-osmotic stimuli. SIADH usually results from a disease or an agent that enhances AVP release or action.



Causes of SIADH

- Neoplastic diseases
 - Carcinoma (lung, pancreas, duodenum, bladder, prostate)
 - Lymphoma, leukaemia
 - Ewing's sarcoma, mesothelioma
 - Thymoma (carcinoid).
- Pulmonary disorders
 - Pneumonia
 - Tuberculosis
 - Asthma, pneumothorax
 - Cavitation, abscess
 - Positive pressure breathing
 - Empyema
 - Cystic fibrosis.
- Central nervous system disorders
 - Head injury
 - Meningitis, encephalitis, abscess
 - Guillain-Barré syndrome
 - Cerebrovascular accident
 - Brain tumours
 - Epilepsy
 - Porphyria
 - Peripheral neuropathy
 - Hydrocephalus
 - Shy-Drager syndrome
 - Cavernous sinus thrombosis
 - Multiple sclerosis
 - Psychosis, delirium tremens.
- Drugs
 - Desmopressin, oxytocin
 - Chlorpropamide
 - Clofibrate
 - Vincristine, vinblastine
 - Cyclophosphamide
 - Carbamazepine
 - Phenothiazines
 - Haloperidol
 - Tricyclic antidepressants
 - Monoamine oxidase inhibitors
 - Nicotine
 - Thiazide diuretics.

In patients with SIADH there is a persistent production of AVP or AVP-like peptide despite body fluid hypotonicity. As a result of the sustained release of AVP, patients retain ingested water and become hyponatraemic and mildly volume expanded.



Clinical Features

The signs and symptoms of SIADH are those of water intoxication.

In acute hyponatraemia, with serum sodium concentration less than 120 mEq/litre, the syndrome is manifest by somnolence, seizures, coma, and a high mortality rate.

In chronic hyponatraemia, even though the serum sodium level may be less than 125 mEq/litre, the patient may remain asymptomatic.

When serum sodium is between 115-120 mEq/litre, the common symptoms are anorexia, nausea, vomiting, headache, and abdominal cramps.

Lab Diagnosis

1. Hyponatraemia and low plasma osmolality (hallmark of SIADH).
2. Urine osmolality low but higher than that of plasma.
3. Plasma AVP level elevated in relation to plasma osmolality.
4. Hypouricaemia.

Other causes of hyponatraemia should be excluded such as severe congestive heart failure, cirrhosis of liver with ascites, renal failure, or administration of large volume of hypotonic fluids, all of which can cause dilutional hyponatraemia.

Salt-losing states such as diarrhoea, adrenal insufficiency or renal disease can also give rise to hyponatraemia, but there is associated hypovolaemia.

Pseudo hyponatraemia can result from hyperlipidaemia or severe hyperglycaemia. Hyponatraemia can also result from hypothyroidism and primary polydipsia.

In hyperlipidaemia and hyperlipidaemic states like hypothyroidism, the osmolality of plasma increases which in turn draws out intracellular fluid causing dilutional hyponatraemia.

SIADH is a diagnosis of exclusion.

SIADH can be Differentiated from the Above Conditions as Follows

Diagnosis	Volume status	Urinary sodium concentration (mEq/litre)	Fractional excretion of sodium (%)
SIADH	Normovolaemia	> 20	> 1
Salt wasting			
Renal	Hypovolaemia	> 20	> 1
Extrarenal	Hypovolaemia	< 10	< 1
Dilutional hyponatraemia	Hypervolaemia	< 10	< 1



Treatment

Management of acute or symptomatic hyponatraemia with a serum sodium concentration less than 120 mEq/litre is a medical emergency. The immediate goal is to raise serum sodium to 125 mEq/litre. The sodium requirement can be calculated according to the following formula:

Sodium requirement = (125 – measured sodium) × 0.6 body weight

Sodium replacement can be accomplished by infusion of hypertonic saline (3%). Rapid rise of serum sodium to levels more than 125 mEq/litre may cause CNS damage such as central pontine myelinolysis. So it is always prudent to correct sodium concentration at the rate of 0.5-1 mEq/hour.

Management of asymptomatic chronic hyponatraemia is done by fluid restriction to 800-1000 ml/day or if patient cannot restrict the fluid intake, drugs like demeclocycline (0.62-1.2 g/day) or lithium (these agents interfere with the renal tubular effects of AVP) can be used, and they gradually raise plasma osmolality and serum sodium concentration to normal levels.

Thyroid Disorders

Anatomy and Physiology of Thyroid Gland

Thyroid is an endocrine gland responsible mainly for the maintenance of a normal basal metabolic rate of the body. Anatomically it comprises of two lobes connected together by an isthmus. Histologically it is made up of follicular cells (which secrete thyroid hormones) and parafollicular C-cells (which secrete calcitonin).

The thyroid secretes predominantly thyroxine (T₄) and only a small amount of triiodothyronine (T₃). Production of T₃ and T₄ in the thyroid is stimulated by thyroid-stimulating hormone (TSH) released from the anterior pituitary in response to stimulation by thyrotropin releasing hormone (TRH) released by the hypothalamus. T₃ and T₄ (> 99.9%) circulate in plasma bound to thyroxine binding globulin (TBG). The minute fraction of unbound (free) hormone diffuses into tissues and exerts its metabolic action.

There is a negative feedback of thyroid hormones on the pituitary and so when plasma concentrations of T₃ and T₄ are raised (hyperthyroidism), TSH secretion is suppressed, and conversely when concentration of T₃ and T₄ are decreased (primary hypothyroidism), TSH level is elevated.



Patterns of Thyroid Function Tests in Patients with Thyroid Disease

Type of disease	T_4	T_3	TSH
Conventional hyperthyroidism (95%)	Raised	Raised	Undetectable
T3 hyperthyroidism (5%)	Normal	Raised	Undetectable
Subclinical hyperthyroidism	Normal	Normal	Undetectable
Primary hypothyroidism	Low	Not indicated	Raised
Subclinical hypothyroidism	Normal	Not indicated	Raised
Secondary hypothyroidism	Low	Not indicated	Undetectable

Hyperthyroidism

Hyperthyroidism is the condition resulting from the effect of excessive amounts of thyroid hormones on body tissues.

- Thyrotoxicosis is defined as a state of thyroid hormone excess.
- Hyperthyroidism is defined as a state of excess thyroid gland function.



Causes

Common causes (account for 95% of cases)

1. Graves' disease (autoimmune) 75%
2. Multinodular goitre 15%
3. Solitary thyroid nodule 10%

Rare causes (account for 5% of cases)

1. Thyroiditis (viral, autoimmune, postradiation)
2. Thyrotoxicosis factitia (surreptitious T_4 consumption, especially by female health workers)
3. Exogenous iodine consumption
4. Drugs (amiodarone)
5. TSH secreting tumours (pituitary tumours)
6. HCG producing tumours
7. Struma ovarii (ovarian teratoma).



Clinical Features (Figs 9.8 to 9.11)

1. The skin is warm, moist (due to vasodilatation); the palms are warm, moist and hyperaemic (palmar erythema); Plummer's nails (retraction of nail from its bed) are seen.
2. Dermopathy in the form of peau d'orange (pretibial myxedema) and growth of coarse hair may be seen.
3. Alopecia and vitiligo may be seen (vitiligo may be a marker for autoimmune aetiology for hyperthyroidism).



Fig. 9.8: Thyrotoxic ophthalmopathy

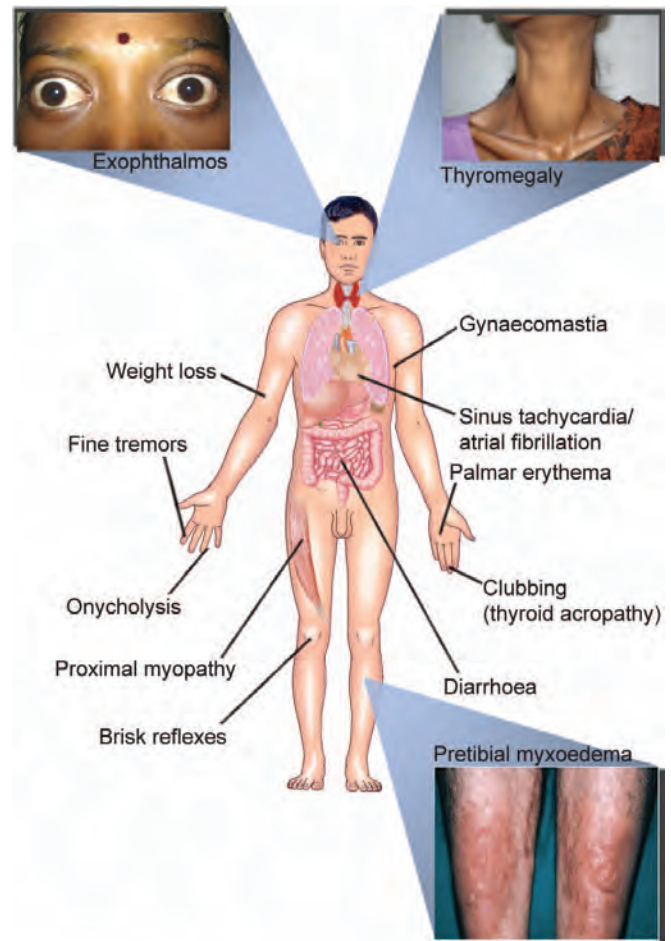

Fig. 9.9: Clinical features of hyperthyroidism



Fig. 9.10: Thyrotoxicosis with myasthenia gravis



Fig. 9.11: CT orbits—thickened extraocular muscles in thyrotoxicosis

4. The eyes show retracted upper eyelid (due to increased sympathetic tone) and wide palpebral fissures (the upper limbus is well seen). In severe cases, proptosis may be seen.

Eye Signs in Hyperthyroidism

- Von Graefe’s—Lid lag
- Joffroy’s—Absence of wrinkling of forehead on looking up
- Stellwag’s—Decreased frequency of blinking
- Dalrymple’s—Lid retraction exposing the upper sclera (Fig. 9.12)
- Möbius—Absence of convergence.



Figs 9.12A and B: (A) Bilateral proptosis with eyelid retraction (B) Bilateral lagophthalmos

Common Symptoms of Grave's disease	Frequency-%
• Nervousness, irritability	99
• Increased perspiration	90
• Easy fatiguability	90
• Heat intolerance	85
• Weight loss	85
• Tachycardia	80
• Muscle weakness	70
• Insomnia	65
• Increased appetite	65
• Reduced job performance	60
• Eye complaints	55
• Hyperdefecation	30
• Anorexia and constipation (may be due to associated hypercalcemia)	51

Symptoms of Hyperthyroidism in Elderly

- CVS - arrhythmia – AF
- CVS - angina and CHF
- CNS – Dementia, delirium, depression
- GIT – Constipation > diarrhoea
- Constitutional – Anorexia, weight loss

Grading of Eye Signs

NO SPECS

- No eye signs
- Only sign seen in upper eyelid



- Soft tissue involvement
- Proptosis
- Extraocular muscle affected
- Corneal involvement
- Sight loss—due to optic nerve involvement

Grading of Eye Changes

Grading	Features
0	No eye signs
I	Only sign seen is upper eyelid retraction (lid lag sign)
II	Soft tissue involvement with upward gaze palsy and proptosis upto 22 mm
III	Proptosis more than 22 mm with symptoms of epiphora, redness of eye and gritty sensation in the eye
IV	Involvement of extraocular muscles (ophthalmoplegia)
V	Corneal involvement (ulceration)
VI	Optic nerve involvement (complete blindness)

- Cardiovascular symptoms are palpitations (due to AF, SVT). CCF may be precipitated in long-standing cases. Sleeping pulse rate is greater than 90 per minute. Isolated systolic hypertension can occur.
- Metabolic symptoms are weight loss despite the increased appetite and intolerance to heat (due to increased BMR).
- GIT symptoms may be in the form of hyper-defaecation.
- It may exacerbate bronchial asthma
- CNS symptoms are nervousness and irritability (very common symptoms). There is fine tremor of outstretched hands, insomnia, inability to relax and proximal muscle weakness. Acute psychosis may occur in about one third of patients with hyperthyroidism.
- Women may have amenorrhoea or oligomenorrhoea and men may have impotence and loss of libido.

On examination, the thyroid gland may be diffusely enlarged and bruit may be heard over the gland due to increased blood flow.



Investigations

- Serum free T_3 and T_4 levels are elevated
- Serum TSH level is not detectable
 - Plasma TSH level > 0.1 microunits/mL excludes clinical hyperthyroidism
 - Plasma level of TSH < 0.1 microunits/mL may indicate mild or subclinical hyperthyroidism and plasma free T_4 is elevated
 - Plasma level of TSH < 0.1 microunits/mL, but free T_4 is normal with clinical evidence of

High RAIU	Low RAIU
Grave's disease	Subacute thyroiditis
Toxic multinodular goitre	Painless thyroiditis
Toxic adenoma	Grave's disease with acute iodine load
Hashitoxicosis	Iodine induced hyperthyroidism
Choriocarcinoma	Thyroid hormone therapy
Hydatidiform mole	Metastatic functioning thyroid carcinoma
TSH secreting pituitary tumour	Struma ovarii

hyperthyroidism and is due to elevation of plasma T_3 .

- TSH may also be suppressed in severe non-thyroidal illness. In this situation, a third-generation TSH assay with a detection limit of 0.02 microunits/mL is helpful. Most patients with clinical hyperthyroidism have plasma TSH level < 0.02 microunits/mL. Non-thyroidal illness does not suppress TSH to this level.
- Thyroid uptake of radioiodine (^{131}I) is increased

The test is performed by administering I^{123} orally and measuring the percentage of radionuclide uptake after 4-24 hours. It is most useful for differentiating between high and low uptake types of hyperthyroidism and it should be performed when Graves' disease is not evident.
 - Test for presence of antibodies
 - Thyroid stimulating immunoglobulin (TSI) is a marker for Graves' disease
 - TSH-receptor antibody is seen in 75% of patients with Graves' disease
 - Antimicrosomal (antiperoxidase) antibody is seen in Graves' disease and also in Hashimoto's thyroiditis.
 - Thyroid scan with radioactive iodine is useful in patients with nodular goitre and hyperthyroidism to determine
 - Whether there is an autonomous hyperfunctioning nodule.
 - Whether multiple nodules are hyperfunctioning
 - Whether the nodules are cold and the hyperfunctioning tissue is between the nodules.



Treatment

- Immediate control of symptoms can be achieved with propranolol 40 mg/6 hr orally
- Long-term control of hyperthyroidism can be by use of antithyroid drugs, radioiodine, or surgery
 - Antithyroid drugs:* Carbimazole 15 mg tid initially and then reducing to 5 mg tid for 12-18 months,

Management Options for Hyperthyroidism of Graves' Disease

Management	Indications
Antithyroid drugs	First episode in patients less than 40 years
Subtotal thyroidectomy	<ol style="list-style-type: none"> Recurrent hyperthyroidism after course of antithyroid drugs in patients less than 40 years Initial treatment in males with large goitres and in those with severe hyperthyroidism (total $T_3 > 9$ nmol/litre) Poor drug compliance
Radioiodine	<ol style="list-style-type: none"> Patients > 40 years Recurrence following surgery irrespective of age Other serious illness irrespective of age

gives symptomatic relief. Relapse may occur in approximately 70% of patients within two years and is commoner with large goitres and severe disease. Adverse reactions such as rashes and neutropenia are relatively common.

There are two types of regimens for giving antithyroid drugs.

- Titration regimen:** Titrate the dose every 3-4 weeks according to free T_4 level. TSH often remains suppressed for several months and do not provide a sensitive index for treatment response.
- Block – replacement regimen:** Use high dose antithyroid drugs along with levothyroxine supplementation. 30-50% remission is achieved in 6 months.

Among these titration regimen is preferred.

- Radioiodine ablation of the hyperfunctioning thyroid tissue may be adopted for post-menopausal women and elderly men. Hypothyroidism is common after treatment, and may require replacement therapy. It can also be given in recurrent hyperthyroidism. When given for a fertile female, conception must be postponed for one year.
- Surgery should be undertaken only after the thyrotoxic crisis has been controlled. Hypothyroidism is common and relapse of thyrotoxicosis and hypoparathyroidism may occur. Surgery is indicated in presence of large goitres causing stridor or dysphagia or in patients not responding to adequate medical treatment.
 - A thionamide is given until the patient is nearly euthyroid.

- Supersaturated potassium iodide 40-80 mg (1-2 drops) bid 1-2 weeks before surgery.
 - Atenolol 50-100 mg daily two weeks before surgery to reduce the heart rate < 90/min.
 - Both thionamide and iodide can be stopped postoperatively.
- Exophthalmos is best treated with high dose corticosteroids but may require tarsorrhaphy and/or orbital decompression.
 - Cardiac arrhythmias especially AF may respond poorly to digoxin and β -blockers are often required. Once the patient is euthyroid, cardioversion may be considered.
 - Warfarin should be added.

Thyrotoxic Crisis (Thyroid Storm)

In this condition, there is rapid deterioration of thyrotoxicosis with hyperpyrexia, severe tachycardia, high output cardiac failure and extreme restlessness.

It is usually precipitated by stress or infection in a patient with inadequate control of his thyrotoxic state or during thyroid surgery when the thyrotoxic state of the patient had not been adequately controlled in the preoperative state, or when patient with hyperthyroidism is treated with radioiodine.

It is a medical emergency. Treatment is started immediately with

- Propranolol 80 mg/6 hrs orally (it may be given IV in a dose of 1-5 mg 6th hourly)
- Potassium iodide 60 mg daily, orally or sodium iopodate 500 mg per day orally may be given (reduces T_3 level to normal in 48-72 hours)
- Carbimazole 60-120 mg daily (inhibits synthesis of new thyroid hormones)
- Injection dexamethasone 2 mg IV 6th hourly
- Fluid replacement
- Appropriate antibiotics for treatment of underlying infection, if present.

RAI Therapy

- A single dose permanently controls hyperthyroidism in 90% of cases.
- A 24 hour RAIU is usually measured to calculate the required dose.
- In fertile women, do a pregnancy test before RAI therapy.
- Thionamides interfere with RAI therapy and should be stopped 3 days before treatment.
- Iodine treatment should be stopped 2 weeks before treatment.



- Most patients require 10 mCi of radioactive iodine.
- If hypothyroidism develops, thyroxine therapy is initiated.
- If symptomatic hyperthyroidism persists after 6 months, RAI therapy is repeated.
- It does not increase the risk of malignancy.
- Therapy is very safe in non-pregnant fertile women. Conception is permitted after an interval of 6 months. No increase in congenital abnormality in the offspring of women after RAI therapy. The radiation to the ovaries is meagre.

Hyperthyroidism in Pregnancy

- If TSH is < 0.1 microunits/mL, confirm the diagnosis by measuring plasma T_4 .
- PTU should be used to treat hyperthyroidism in pregnancy.
- RAI therapy is contraindicated in pregnancy.
- Atenolol 25-50 mg PO can be used.
- Neonate should be monitored for hyperthyroidism.

Neonatal Hyperthyroidism (Neonatal Graves' disease)

- Uncommon disorder in infants born to mother with Grave's disease
- Their mothers with Graves' disease have very high thyrotropin receptor stimulating antibody (TRS Ab) concentration
- It occurs as a result of trans-placental passage of TRS Ab.

In most infants, neonatal Graves' disease resolves spontaneously in 3-12 weeks as the maternal TRS Ab disappears from infant's blood. Sometimes thyrotoxicosis can persist for years and have long-term sequelae. Many of these infants have an activating mutation of TSH receptor. Neonatal hyperthyroidism has also been reported in McCune-Albright syndrome caused by an activating mutation in α subunit of a protein.



Clinical Features

- Fetal tachycardia- >160/mt
- Intrauterine growth retardation
- Low birth weight
- Microcephaly and ventricular enlargement
- Exophthalmos
- Goitre – can cause airway obstruction
- Hyperactive irritable infants
- Increased sweating
- Increased appetite

- Hepatosplenomegaly and jaundice
- Other symptoms and signs – vomiting, diarrhoea, jaundice, convulsions, coma, death.
- Mortality – 30%



Investigations

1. Maternal TRS Ab level > 500% of control values
2. Abnormally elevated T_4 , T_3 and decreased TSH
3. X-ray – accelerated bony maturation.



Complications

1. Cardiac arrhythmias
2. Cardiac failure
3. Respiratory obstruction
4. Craniosynostosis
5. Intellectual impairment
6. Pituitary hypothyroidism



Management

- Mild cases – Observation/propranolol
 - Moderate/severe cases – Immediate vigorous treatment
 - a. Propylthiouracil 5-10 mg/kg/day or Methimazole 0.5 – 1.0 mg/kg/day 8th hourly
 - b. Propranolol 2 mg/kg/day and if no improvement in four days, double the dose can be used
 - c. PTU 600 mg stratum followed by 200–300 mg qid PO.
 - d. Adjunctive therapy – digoxin for heart failure
Relief of airway obstruction due to goitre:
Mild cases—simple neck extension
Severe cases—ET intubation
 - e. Nasal oxygen.
- Improvement is often seen in 7-10 days with remission by 3-6 weeks.

Hypothyroidism

Hypothyroidism is the condition resulting from insufficient synthesis of thyroid hormones.

Hypothyroidism dating from birth is termed cretinism. The term myxoedema indicates severe hypothyroidism in which there is accumulation of hydrophilic mucopolysaccharides in the skin and other tissues.

In children, the earlier the age of onset of hypothyroidism, the greater the chance of brain damage especially before 3 years. Thyroxine is essential for growth and development of the CNS during the first

3 years. After 3 years, most of the effects of hypothyroidism are reversible.



Causes

- I. Primary thyroid diseases (accounts for 95% of cases):
 - a. *Thyroprivic*
Congenital developmental defects
Primary idiopathic
Post-ablative (radioiodine or surgery)
Post-radiation (e.g. lymphoma)
 - b. *Goitrous*
Heritable biosynthetic defects maternal transmission
Iodine deficiency
Drug induced (PAS, iodide, phenylbutazone, lithium and amiodarone)
Chronic thyroiditis—(Hashimoto's disease)
 - c. Recurrent hypothyroidism
- II. Suprathyroidal (accounts for 5% of cases):
 - a. Pituitary—postpartum pituitary necrosis (Sheehan's syndrome)
 - b. Hypothalamic.
- III. Drugs that cause hypothyroidism:
 - Iodine containing drugs
 - Lithium
 - Interferon- α
 - Interleukin-2
 - Thalidomide.



Clinical Features

Congenital Hypothyroidism

Symptoms

Lethargy, somnolence, constipation, poor feeding/sucking, cold to touch, delayed dentition and mental retardation (Figs 9.13 and 9.14).

Signs

Dry, cool, mottled skin, hoarse cry, coarse face, broad flat nose, large protruding tongue, puffy face.
Abdomen—Protuberant, umbilical hernia, hypotonia
Skull—Large posterior fontanelle.

Investigations

1. Cord blood T_4 , TSH
2. Serum T_4 and TSH
3. RAIU—optional
4. X-ray—Knee—Lower femoral/upper tibial epiphyses absent



Fig. 9.13: Congenital hypothyroidism



Fig. 9.14: A child with cretinism

Foot—Cuboidal epiphysis absent
Skull—Sella size—suprasellar calcification, wide sutures, large fontanelles

Acquired Hypothyroidism

Symptoms

Juvenile

Short stature (upper segment more than the lower segment)
Delayed dentition
Poor performance at school
Delayed sexual maturation

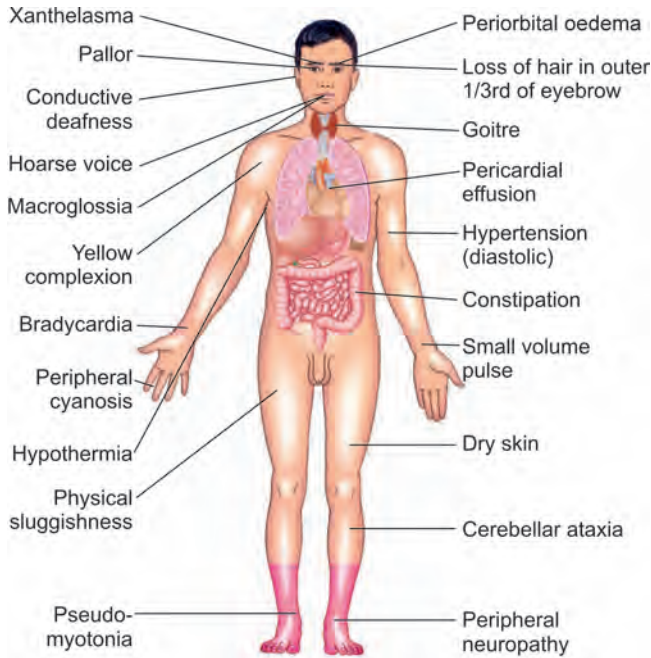

Fig. 9.15: Clinical features of hypothyroidism



Fig. 9.17: Face in hypothyroidism



Fig. 9.16: Calf muscles hypertrophy—Hoffman's syndrome

Proximal myopathy (Hoffman's syndrome adults)
Kocher-Debre-Semalaigne syndrome (children)

Adult (Figs 9.15 to 9.17)

General Tiredness, lethargy, somnolence, weight gain, poor appetite, cold intolerance
Skin Cool, coarse, dry and flaky

Colour	Pallor/yellowish due to carotenaemia
Hair	Sparse, brittle, loss of eyebrows
Nails	Brittle
Skeletal	Short stature
Muscular	Pain, stiffness, cramps, muscle weakness, hypotonia, delayed relaxation phase of deep tendon reflexes (pseudomyotonic reflex)
Neurological	Higher functions show memory impairment and mental slowing and depression, 8th N deafness Carpal tunnel syndrome Sensory ataxia (if subacute combined degeneration is present) Cerebellar ataxia Acute encephalopathy
Cardiovascular System	Bradycardia Diastolic hypertension (increased peripheral vascular resistance) Cardiomegaly with pericardial effusion
Gastrointestinal System	Macroglossia, GIT hypomotility, Ascites, Achlorhydria
Reproductive System	
Female	Menorrhagia, amenorrhoea, infertility and abortion
Male	Impotence, scrotal effusion
Metabolic	Hypothermia, hypercholesterolaemia, decreased insulin requirement
Eye	Yellow sclera
Respiratory system	Vocal cord oedema leads to low pitched and hoarse voice (due to

	infiltration of mucopolysaccharides), pleural effusion, respiratory muscle weakness
Haematology	Normocytic normochromic anaemia, Iron deficiency anaemia (menorrhagia), Megaloblastic anaemia (associated with pernicious anaemia)

Myxoedema Coma (Hypothermic Coma)

It is a state of hypothermia (body temperature may drop to as low as 25° C), hypotension, convulsions, hypoglycaemia, hyponatraemia, hypoventilation and coma.

Precipitating factors	Cold, stress, sepsis, surgery, CNS depressant drugs
	Increasing age
	Pneumonia, congestive cardiac failure, MI, GI bleeding, CVA, hypoglycaemia, hypoventilation and dilutional hyponatraemia.
	100% mortality if untreated.

Difference between Primary and Secondary Hypothyroidism

Features	Primary hypothyroidism	Secondary hypothyroidism
1. Skin	Coarse	Soft and silky
2. Blood pressure	Hypertension or normal	Hypotension or normal
3. Menstrual cycle	Menorrhagia	Amenorrhoea
4. Trans cardiac diameter	Increased	Normal or decreased
5. Serum TSH	Increased	Decreased
6. Serum cholesterol	Increased	Not altered
7. Evidence of deficiency of other pituitary hormones	Absent	Present



Investigations

1. Serum thyroxine (T₄) concentration
2. Free T₄ index
3. Serum TSH concentration
 - TSH elevation > 20 microunits/mL confirms the diagnosis of primary hypothyroidism.
 - Mild elevation of TSH < 20 microunits/mL usually indicates mild or subclinical hypothyroidism. Mild elevation may also be due to nonthyroidal illness and measurement of plasma free T₄ is helpful.

- In secondary hypothyroidism, TSH value is not helpful and measurement of plasma free T₄ confirms the diagnosis of hypothyroidism.
 - In secondary hypothyroidism, plasma TSH cannot be used to adjust therapy, but plasma free T₄ is useful to guide therapy.
4. Serum cholesterol
 5. Serum sodium
 6. Serum CPK—MM, aldolase, LDH, SGOT
 7. ECG—Low voltage, bradycardia, T wave flattening.
 8. Echo—Pericardial effusion, ↓ pre ejection time of LV.



Treatment

1. Replacement of the deficient hormone is the basis of therapy. The dose is 100-300 µg per day as single PO of thyroxine (1.6 mcg/kg/day)
2. In elderly and those with heart disease, it is better to start with small dose 25-50 µg per day and then increase by 25-50 µg every 2 or 3 weeks until a full maintenance dose is reached. It is monitored clinically and biochemically. TSH should be maintained in lower half of normal limits.
3. The treatment is usually life long.
4. In patients with pituitary hypothyroidism, thyroid hormone replacement should not be instituted until, replacement with hydrocortisone has been initiated (as it may result in adrenal crisis).
5. If patients develop angina with thyroxine, β blocker should be added.
6. Thyroxine dose increases by 50% in the first half of pregnancy. Periodic TSH estimation is essential to adjust the dose of thyroxine till the end of second trimester.

Sub-clinical Hypothyroidism

- Increased TSH but T₄ and T₃ remains normal.
- Seen in 10% of those > 55 years
- Common after partial thyroidectomy or I¹³¹ therapy
- Risk of progression to frank hypothyroidism -2% and this risk doubles if thyroid autoantibodies are present.

Management

- Check thyroid antibodies
- Treat if TSH > 10 IU or with positive thyroid antibodies or h/o previous Graves' disease or presence of other organ specific autoimmunity
- In the absence of above criteria, monitor TSH annually.



Myxoedema Coma

1. L-thyroxine 400-500 µg IV should be given as a bolus injection, or orally through Ryle's tube Triiodothyronine (T₃) 20 µg IV every 8 hours till there is sustained clinical improvement
2. Steroid (hydrocortisone hemisuccinate 100 mg IV 8th hourly) and IV fluids till results of serum T₃, T₄, TSH and cortisol are obtained. If serum cortisol level is normal, then steroid may be discontinued
3. Subsequent parenteral maintenance dosage may be about 100 µg of L-thyroxine/day
4. Treatment of underlying infection
5. Rewarming the patient with electrical space blanket
6. Ventilatory support is necessary especially in persistent hypoxaemia, hypercapnoea and respiratory acidosis.
7. Other measures include correction of hypoglycaemia, electrolyte imbalance, broad spectrum antibiotics and high flow oxygen.

Thyroiditis

These form a group of heterogenous inflammatory disorders of varying aetiologies.

Types

1. Acute
2. Subacute
 - a. Granulomatous
 - b. Lymphocytic
3. Chronic
 - a. Hashimoto's thyroiditis
 - b. Riedel's struma.

Acute Thyroiditis

Suppurative Thyroiditis (Pyogenic or Bacterial Thyroiditis)

It is a rare disorder caused by *Staph. aureus*, streptococci, *Strep. pneumoniae*, *Salmonella*, *E. coli*.

It occurs by direct introduction of infection, by trauma or by lymphatic or hematogenous spread.



Clinical Features

Fever, chills, pain over the gland, anterior neck swelling and sometimes an abscess over the thyroid gland may be noticed.

Lab Diagnosis

1. Leucocytosis with shift to left (immature leucocytes)
2. Normal T₃, T₄

3. Radioactive iodine uptake is reduced
4. Fine needle aspiration for smear and culture
5. Elevated ESR.



Differential Diagnosis

1. Subacute thyroiditis
2. Cellulitis of anterior neck
3. Acute haemorrhage into a thyroid cyst, adenoma or carcinoma
4. Infected thyroglossal duct or cyst.



Treatment

1. Appropriate parenteral antibiotics (according to results of culture and sensitivity)
2. Incision and drainage if abscess is present.

Subacute Thyroiditis

Granulomatous thyroiditis (Viral or de Quervain's Thyroiditis)

This may be caused by a virus (coxsackie virus, adenovirus, mumps, ECHO, influenza, EBV) Genetic predisposition is associated with HLA BW35.



Clinical Features

1. Unilateral anterior neck pain with radiation to ear or mandible
2. Low grade fever and malaise
3. Sore throat
4. Dysphagia is a common symptom
5. Symptoms and signs of hyperthyroidism in 50% of patients
6. Hard tender unilateral nodular enlargement of the gland
7. There are three phases of presentation.
 - a. Thyrotoxic phase
 - b. Hypothyroid phase
 - c. Recovery phase.

Lab Diagnosis

1. ESR is usually elevated > 50 mm/hr
2. T₃ and T₄ are elevated
3. Antimicrosomal and antithyroglobulin antibodies are negative
4. Radioactive iodine uptake is decreased in the acute phase due to disruption of iodine trapping mechanism.

**Treatment**

1. In the initial phase, which lasts for 4-8 weeks, aspirin 600 mg 4th hourly, or other NSAIDs may be given (to decrease pain)
2. Prednisolone 20 mg TID, and tapered by 2 mg every 2-3 days, after 1 week
3. Symptoms of hyperthyroidism may be controlled with propranolol 20-40 mg 3-4 times daily orally.
4. Antithyroid drugs are not indicated.

After the acute phase, usually patient becomes euthyroid. In severe cases, hypothyroidism may result which rarely lasts for > 2-3 months during which phase, 1-thyroxine 0.1-0.15 mg/day should be given which may be discontinued after patient attains the euthyroid state.

A new syndrome of *P. carinii* thyroiditis has been reported which clinically simulates subacute thyroiditis, commonly seen in patients with AIDS.

It is particularly common in those patients who are on aerosolized pentamidine prophylaxis for *P. carinii* pneumonia, as the infecting organism lodges at other sites like the thyroid instead of the lungs which are protected by the aerosolized pentamidine.

Diagnosis is confirmed by fine needle aspiration and staining of *P. carinii* with Gomori silver methanamine.

Lymphocytic Thyroiditis (Painless Thyroiditis, Silent Thyroiditis, Lymphocytic Thyroiditis with Spontaneously Resolving Hyperthyroidism)

It is a painless thyroiditis characterised by abrupt onset of hyperthyroid symptoms, elevated total and free T₃ and T₄ levels, and a low radioactive iodine uptake. There is a painless non-tender goitre.

It is thought to be of autoimmune origin.

Genetic predisposition is likely to be associated with presence of HLA-DRW3, HLA-DRW5.

**Clinical Features**

- Signs and symptoms of hyperthyroidism are present.
- The hyperthyroid phase lasts for 6 weeks to 3-4 months and rarely longer.
- It may occur post-partum 6 weeks to 3 months after delivery.
- Physical examination may reveal mildly enlarged, diffuse firm, non-tender goitre.

The clinical features of painless thyroiditis is difficult to distinguish from that of Graves' disease in the

hyperthyroid phase. Clinical characteristics that are helpful in differentiating the two disorders are as follows:

**Treatment**

In the initial hyperthyroid phase, patient may be treated with propranolol 20-40 mg 3-4 times/day. Carbimazole or propylthiouracil are not useful.

Following hyperthyroid phase, there is a euthyroid phase lasting 3-6 weeks.

Clinical features	Painless thyroiditis	Graves' disease
1. Onset	Abrupt	Gradual
2. Severity of symptoms	Mild to moderate	Moderate to severe
3. Duration of symptoms	< 3 months	> 3 months
4. Goitre	Very firm, diffuse, mildly enlarged	Soft to firm, diffuse, large
5. Thyroid bruit	Absent	Often present
6. Exophthalmos, dermatopathy	Absent	May be present
7. T ₃ and T ₄ ratio	< 20:1	> 20:1
8. Radioactive iodine uptake	Suppressed	Elevated

This may be followed by a hypothyroid phase which may last for 2-3 months during which hormone replacement therapy with 1-thyroxine 0.10-0.15 mg/day may be required.

Chronic Thyroiditis

Hashimoto's Thyroiditis (Chronic Lymphocytic Thyroiditis, Chronic Thyroiditis Struma Lymphomatosa)

It is an organ specific autoimmune disorder. A genetic predisposition is suggested owing to the presence of HLA-DR5 histocompatibility antigen.

It may be associated with a variety of other organ specific autoimmune disorders as listed below:

1. Endocrine disorders
 - Graves' disease
 - Type 1 diabetes mellitus
 - Idiopathic Addison's disease
 - Autoimmune orchitis or oophoritis
 - Idiopathic hypoparathyroidism.
2. Non-endocrine, organ-specific autoimmune disorders
 - Pernicious anaemia
 - Vitiligo
 - Rheumatoid arthritis
 - Idiopathic thrombocytopenic purpura



- Myasthenia gravis
 - Sjögren's syndrome
 - Chronic active hepatitis
 - Lupus erythematosus
 - Primary biliary cirrhosis.
3. Other disorders
- Renal tubular acidosis
 - Down's syndrome
 - Turner's syndrome.



Clinical Features

This may present with clinical features of either hypothyroidism or hyperthyroidism (Hashitoxicosis) or the patient may be euthyroid, each of these manifestations presenting with or without a goitre.

- Hypothyroid phase – 4-12 weeks
- Resolution phase
- Normal ESR
- TPO ab (+ve)

Lab Diagnosis

1. T₃, T₄ and TSH may be normal
2. Antithyroglobulin antibody, antimicrosomal antibody and antithyroperoxidase antibody may be detectable in 85% of patients
3. Thyroid scan shows symmetrically enlarged thyroid with an irregular pattern of iodine uptake (cold nodule)
4. Radioactive iodine uptake may be increased, decreased or normal
5. Fine needle biopsy is done when there is a nodule or if there is growth of the gland, to rule out malignancy.



Treatment

Thyroid hormone is given in full replacement doses (2-3 µg/kg/day) indefinitely in patients with hypothyroidism. This also corrects the enlargement of the gland

if present and thereby relieves symptoms of compression by the enlarged gland.

In patients who are euthyroid, with goitre, and who have normal serum T₄ and elevated TSH, thyroid hormone treatment is given as these patients subsequently become clinically hypothyroid.

Glucocorticoids have been reported to be effective when there is rapidly enlarging goitre associated with pressure symptoms. They should be withdrawn once the symptoms have subsided.

Surgery may be indicated if there is significant pressure symptoms not relieved medically.

Riedel's Thyroiditis (Riedel's Struma)

It is a rare inflammatory disorder of uncertain aetiology. Clinically it presents with pressure symptoms.

Physical examination reveals an extremely hard and immobile thyroid swelling.

It may be associated with other focal sclerosing syndromes like retroperitoneal, mediastinal fibrosis and ascending cholecystitis.

Thyroid function tests show hypothyroidism in 25% of patients.

Thyroid antibodies are usually absent.

Thyroid scan shows decreased iodine uptake in the involved areas.

Treatment is surgical removal in those who present with pressure symptoms.

Thyroid hormone replacement may be given for patients presenting with hypothyroidism, but this does not result in shrinkage of the enlarged thyroid gland.

Amiodarone Induced Thyroid Dysfunction

- i. Thyrotoxicosis – Stop amiodarone and treat with antithyroid drugs.
- ii. Hypothyroidism – Continue amiodarone and replace eltroxin.

Malignant Tumours of the Thyroid

Cell type	Type of tumour	Frequency (%)	Age of presentation (yrs)	Approximate 10 year survival rate (%)	Spread	Therapy
Follicular cell	Papillary	70	20-30	95	Blood/LN	Surgery/Chemo
	Follicular	10	30-40	80	Blood	Chemo
	Anaplastic	5	> 60	< 1	Blood/LN	Chemo/Radio
Parafollicular C-cells	Medullary carcinoma	5-10	> 40*	50	LN	Surgery
Lymphocytes	Lymphoma	5-10	> 60	10	Blood/LN	Chemo/Radio

*Patients with medullary carcinoma as part of multiple endocrine neoplasia syndromes usually present in childhood

Malignant Tumours of the Thyroid

Primary thyroid malignancy is rare, accounting for less than 1% of all carcinomas. With the exception of medullary carcinoma, thyroid cancer is always more common in females. Thyroid malignancy can be classified according to the cell-type of origin.

Medullary Carcinoma

This tumour which arises from the parafollicular C-cells of the thyroid, secretes calcitonin, serotonin, ACTH and prostaglandins, as a consequence of which they may present with carcinoid syndrome and Cushing's syndrome. Patients usually present with a firm thyroid mass. Spread is through lymphatics involving cervical lymph nodes. There is profuse diarrhoea. Serum calcitonin levels are raised and are useful in monitoring response to treatment. Despite the very high levels of calcitonin found in some patients, hypocalcaemia is extremely rare. Treatment is by total thyroidectomy with removal of affected cervical nodes.

Disorders of Parathyroid Gland and Calcium and Phosphorus Metabolism

Anatomy and Physiology

Parathyroid glands are two pairs of glands situated in the posterior aspect of the thyroid gland.

It secretes parathormone (PTH) by chief cells of the gland. This PTH regulates transtubular transport of calcium, phosphorus, magnesium and bicarbonate. The receptor for PTH is situated in the kidney and in osteoblasts.

The metabolism of calcium and phosphorus are under the influence of three hormones

1. Parathormone (PTH)
2. Calcitonin
3. Vitamin D

In addition to parathormone related peptides, cytokines and growth factors have a role in the metabolism.

Actions of Parathormone

1. Causes tubular reabsorption of calcium, magnesium and facilitates excretion of phosphorus and bicarbonate
2. Helps in the formation of 1, 25 (OH)₂ cholecalciferol in kidney, this in turn helps in absorption of calcium from intestine.

3. Mobilisation of calcium from bone along with vitamin D₃.

Vitamin D₃ (Cholecalciferol): Vitamin D is a prohormone present in skin as 7-dehydrocholesterol, which can be converted into cholecalciferol (Vitamin D₃) by exposure to UV light. This is further converted to 25 OH cholecalciferol (calcidiol) by hydroxylation in the liver and finally to the active form of 1, 25 (OH)₂ cholecalciferol (calcitriol) by second hydroxylation in the kidney.

Receptors for 1, 25 (OH)₂ vitamin D₃ are present in number of tissues other than intestine and skeletal muscle (kidney, pancreas, vascular, smooth muscle, haematopoietic cellular elements). This indicates that vitamin D has a number of other functions which are unknown other than that of calcium phosphorus metabolism.

Receptors for parathormone and vitamin D in the skeletal system are present only in osteoblasts and immature osteoclasts. Stimulation of immature osteoclasts by these hormones directly or of the mature osteoclasts indirectly through cytokine released by the osteoblasts results in bone resorption and increase in plasma calcium level.

Calcitonin: This hormone is produced by parafollicular 'C' cells of thyroid gland. It is a hypocalcaemic hormone. Calcitonin secretion is stimulated by increased extracellular calcium level.

Actions of Calcitonin

1. Decreased bone resorption by augmenting osteoblastic activity and inhibiting osteoclasts
2. Decreased tubular reabsorption of calcium resulting in increased excretion.

The measurement of plasma calcitonin has a limited clinical value except that it is a tumour marker for medullary carcinoma of thyroid.

Parathormone Related Peptide (PTHrp)

This is produced by malignant tumours and causes hypercalcaemia by increased osteoclastic activity and increased tubular reabsorption of calcium.



Causes of Hypercalcaemia

Hyperparathyroidism and malignancy account for 90% of hypercalcaemia.

1. *Increased release of calcium from bone*:
 - Primary hyperparathyroidism
 - Malignancies (humoral hypercalcaemia of malignancy, lytic bone metastasis, ectopic cytokine production)



- Immobilisation
 - Thyrotoxicosis
 - Vitamin A intoxication
 - Paget's disease of bone
2. *Increased intestinal absorption of calcium:*
 - Vitamin D intoxication
 - Chronic granulomatous diseases (e.g. sarcoidosis)
 - Malignancy—ectopic 1, 25 (OH)₂, D₃ production
 3. *Decreased renal calcium excretion:*
 - Familial hypocalciuric hypercalcaemia
 - Milk-alkali syndrome
 - Acute renal failure
 4. *Decreased uptake of calcium by bone:*
 - Aluminium toxicity
 5. *Pseudohypercalcaemia:*
 - Macroglobulinaemia
 - Myeloma
 - Hyperalbuminaemia
 6. *Miscellaneous or uncertain pathogenesis:*
 - Thiazide diuretics, metolazone

- Adrenal insufficiency
- Lithium
- Oestrogen, tamoxifen
- Parenteral hyperalimentation
- Pheochromocytoma.

Primary Hyperparathyroidism

Familial primary hyperparathyroidism occur as part of MEN I and MEN II.



Causes

Single adenoma	80%
Multiple adenoma	4%
Carcinoma	1%
Hyperplasia	15%



Clinical Features

80% are asymptomatic.

Treatment of Severe Hypercalcaemia

Treatment	Onset of action	Duration of action	Advantages	Disadvantages
Hydration with saline	Hours	During infusion	Rehydration invariably needed	
Forced diuresis; saline + loop diuretic	Hour	During treatment	Rapid action	Cardiac decompensation, (intensive monitoring needed) electrolyte disturbance, hypokalaemia, hypomagnesaemia
Bisphosphonates				
1st generation Etidronate	1-2 days	5-7 days in doses used	First available bisphosphonate; intermediate onset of action	Hyperphosphataemia; 3-day infusion
2nd generation Pamidronate	1-2 days	10-14 days after high dose	High potency; intermediate onset; prolonged duration of action	Fever in 20%; hypophosphataemia, hypocalcaemia, hypomagnesaemia
3rd generation Zoledronate				
Calcitonin	Hours	2-3 days	Rapid onset of action; useful as an adjunct in severe hypercalcaemia	Often limited calcium lowering effect; rapid tachyphylaxis
Gallium nitrate	Day after 5 days	7-10 days	High potency	Length of IV administration; cannot be used in renal failure
Plicamycin (Mithramycin)	3-4 day	Days	Potent antiresorptive	Liver, kidney, and marrow toxicity; bleeding episodes
Phosphate				
Oral	24 h	During use	Low toxicity if p < 4 mg/dl	Limited use except as an adjuvant or chronic therapy
Intravenous	Hours	During use and 24-48 h afterwards	Rapid action, highly potent	Ectopic calcification; severe hypocalcaemia;
Glucocorticoid	Day	Days, weeks	Oral therapy, antitumour agent	Active only in certain malignancies; glucocorticoid side effects
Dialysis	Hours	During use and 24-48 h afterwards	Useful in renal failure; onset of effect in hours: can immediately reverse life-threatening hypercalcaemia	Complex procedure, reserved for extreme or special circumstances

*dose is pamidronate depending on serum calcium level.

Central Nervous System

Fatigue	Impaired memory
Lassitude	Psychosis
Headache	Dementia
Depression	Coma

Neuromuscular and Articular

Myopathy	Chondrocalcinosis
Gout	Erosive arthritis
Pseudogout	

Ocular

Cataracts	Band keratopathy
-----------	------------------

Cardiovascular

Hypertension	Vascular and cardiac
Arrhythmia	Calcification

Gastrointestinal

Peptic ulcer disease	Cholelithiasis
Reflux gastritis	Constipation

Renal

Polyuria (polydipsia)	Nephrocalcinosis
Urine concentrating defect	Renal tubular acidosis
Nephrolithiasis	

Skeletal (Osteitis Fibrosa Cystica)

Osteopenia and fractures	Osteosclerosis
Bone cysts	Osteomalacia
Brown tumours	

Miscellaneous

Anaemia	Fever
---------	-------

Lab Diagnosis (Figs 9.18 to 9.21)

- Biochemical
 - Simultaneous parathormone and calcium level should be taken
 - Parathormone level is increased
 - Increased calcium (more than 12 mg%), and chloride
 - Decreased phosphorus, potassium and bicarbonate
 - Serum chloride/phosphorus ratio is diagnostic more than 75% (normal < 32%)
- Urinary calcium excretion is increased
- ECG—Short QT interval
- Localisation by USG, CT, MRI, nuclear thallium technetium scan and parathyroid angiography (Figs 9.20 and 9.21).

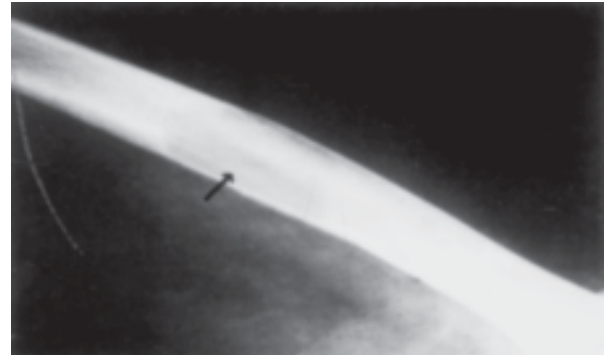

Fig. 9.18: Hyperparathyroidism—osteolytic lesion



Fig. 9.19: Hyperparathyroidism—pepper-pot appearance in lateral view of skull



Fig. 9.20: CT neck—parathyroid adenoma

- Radiological findings in hyperparathyroidism include osteitis fibrosa cystica, subperiosteal erosion especially along the radial aspect of middle phalanx, pepper pot skull (Fig. 9.19).

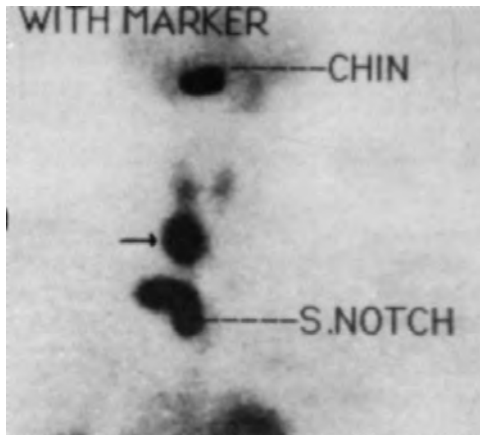

Fig. 9.21: Technetium-sestamibi scan—increased uptake by parathyroid

Rx Treatment

1. Surgery is the definitive treatment. Presence of coma in parathyroid storm or crisis is an indication for urgent medical management followed by surgery
Indications for surgery are:
 - i. symptoms of hypercalcaemia
 - ii. serum $\text{Ca}^{++} > 12 \text{ mg\%}$ (1 mg increase over normal)
 - iii. nephrolithiasis/24 hour urinary calcium excretion $> 400 \text{ mg}$.
 - iv. reduced bone mass (Bone scan T-score < 2.5)
 - v. age < 50 years
 - vi. inability for long-term follow-up
 - vii. Creatinine clearance reduced by 30%.
2. Transcutaneous injection of parathyroid mass with alcohol under ultrasound guide
3. Monitor hypocalcaemia postoperatively for more than 14 days
4. Incidence of complication is high in alcohol ablation.
5. In case of hyperplasia of parathyroid all the 4 glands are surgically removed and part of an excised gland is implanted into the forearm to maintain calcium and phosphorus metabolism
6. Medical treatment is indicated in presence of dangerous hypercalcaemia ($> 15 \text{ mg/dl}$) or when surgical treatment is unsuccessful.

Serum calcium (mg/dl)	Pamidronate (mg)
upto 12	20
14	40
16	60
> 16	80

7. The role for Raloxifene, a selective oestrogen response modulator with bone protective effect of oestrogen is under evaluation.

Familial Hypocalciuric Hypercalcaemia (Familial Benign Hypercalcaemia)

1. Autosomal dominant disorder
2. Renal tubules reabsorb calcium excessively leading to hypercalcaemia, hypermagnesaemia and hypocalciuria
3. The course of disease is benign in adults; but in neonates, symptoms of hypercalcaemia develop
4. It is diagnosed by finding of hypocalciuria of less than 60 mg per 24 hours urine excretion with normal parathormone level
5. Loss of calcium sensing receptor function mutation.

Hypercalcaemic Crisis

It may be the mode of presentation in primary hyperparathyroidism especially in elderly. It presents with dehydration, hypotension, abdominal pain, vomiting, fever, altered sensorium. It is a medical emergency.



Management

Medical Management

1. Rehydration until serum calcium level falls (4-6 litres of normal saline in first 24 hrs)
2. Correct electrolyte imbalance and give frusemide 100 mg 1-2 hours
3. Other methods to decrease serum calcium are:
 - a. Salmon calcitonin 200-400 IU 8 hourly subcutaneously
 - b. Mithramycin 25 $\mu\text{g/kg}$ IV
 - c. Neutral phosphate IV (500 ml over 6-8 hrs)
4. Avoid drugs like digoxin (hypercalcaemia and hypocalcaemia may potentiate its toxicity), thiazides (decrease the calcium excretion), vitamin A, D (increase the bone turnover) oestrogen and antioestrogen.

Hypercalcaemia in Malignancy



Causes

1. Dehydration, immobilisation
2. Local infiltration with osteolysis (myeloma, carcinoma breast)
3. Parathormone related peptides (pseudohyperparathyroidism) in conditions like tumours of lung, kidney, squamous cell carcinoma
4. Ectopic 1, 25 (OH)₂ vitamin D₃ (Hodgkin's lymphoma, seminoma, renal cell carcinoma)
5. Ectopic PTH
6. Oestrogen and antioestrogens (tamoxifen)

7. Prostaglandins, cytokines, TNF, transforming growth factor.



Treatment

1. Adequate hydration
2. Decrease dietary calcium intake
3. Steroids may be tried (transient decrease in calcium level)
4. Ketoconazole decreases calcitriol secretion.

Endocrine Causes of Hyperparathyroidism

1. Hyperthyroidism
2. Pheochromocytoma
3. Adrenal insufficiency
4. MEN I and II.

Secondary Hyperparathyroidism (Increased PTH and Calcium may be Normal or Low)



Causes

1. Renal failure
2. Gastrointestinal malabsorption
3. Vitamin D deficiency (dietary).

It is due to excessive calcium loss, and increased production of parathormone as a compensatory mechanism.



Treatment

Treat the underlying cause.

Tertiary Hyperparathyroidism

In prolonged secondary hyperparathyroidism, the glands become autonomous and the serum calcium level rises secondary to increased parathormone secretion.

Hyperparathyroidism

Type	S calcium	PTH
Primary	Raised	Not suppressed
Secondary	Low	Raised
Tertiary	Raised	Not suppressed

Hypocalcaemic Disorder

Disorder of Parathyroid Glands

1. *PTH deficiency*
 - Surgical hypoparathyroidism
 - Idiopathic hypoparathyroidism
 - Agenesis of parathyroids (DiGeorge syndrome)
 - Metastasis to parathyroid glands

- Granulomatous disease of parathyroids
 - Haemochromatosis
 - Wilson's disease
 - Aluminium toxicity
 - Following ^{131}I therapy
 - Syndromes associated with PTH deficiency are polyglandular autoimmune Type I deficiency, mitochondrial myopathies (Kearn-Sayre syndrome and MELAS— Mitochondrial myopathy, encephalopathy, lactic acidosis and stroke-like episodes)
2. *Suppressed PTH secretion*
 - Hypermagnesaemia
 - WR-2712 (amifostine)
 3. *PTH resistance*
 - Pseudohypoparathyroidism Type Ia, Ib, Ic and II
 - PTH antibodies (iatrogenic)
 - Magnesium depletion
 4. *Accelerated bone remineralisation*
 - Following parathyroid surgery (Hungry Bone syndrome)
 - Following ^{131}I therapy
 - Vitamin D therapy of osteomalacia.



Clinical Features

Symptoms and Signs

Symptoms include muscle spasm, carpopedal spasm (Fig. 9.22), facial grimacing, laryngeal spasm, seizures, and respiratory arrest. Increased intracranial pressure and papilloedema may occur with long standing hypocalcaemia and other manifestations include irritability, depression, psychosis, intestinal cramps, and chronic malabsorption.



Fig. 9.22: Hypoparathyroidism—tetany



Chvostek's sign (contraction of facial muscles on tapping the facial nerve) and Trousseau's sign (carpopedal spasm on raising the BP above the systolic pressure) are frequently positive.

In children: A triad of carpopedal spasm, stridor, convulsions (grand mal, petit mal) are often present.

ECG changes are increased QT-C interval, non-specific. 'T' wave changes.

Soft tissue calcification: Cataract, basal ganglia calcification (chorea, athetosis, parkinsonism), exostosis, chondrocalcinosis, pseudogout.

Haematological manifestation: Macrocytic, megaloblastic anaemia (calcium needed for B₁₂-intrinsic factor binding).

Dental: Delayed dentition, enamel hypoplasia or dysplasia, caries or blunting of root of the teeth.

Nail: Deformed, brittle with transverse grooves.

Lab Diagnosis

1. Decreased PTH level
2. Decreased serum calcium level
3. Increased serum phosphorous level.



Treatment

1. Administration of oral calcium supplements or vitamin D analogues is the mainstay management of hypocalcaemic disorders.
2. In general the therapeutic endpoint is to maintain serum calcium level in the range of 8.5-9.5 mg/dL, with urinary calcium levels below approximately 400 mg/day.
 - a. Oral calcium supplement administered alone (3-7 g/day of elemental calcium) in multiple divided doses can be effective in correcting even moderately severe hypocalcaemia unless a malabsorption syndrome is present.
 - b. Vitamin D analogues are required in special conditions.
 - c. α -calcitriol (0.25-1 mcg/dL) with thiazide diuretic to decrease hypercalciuria.

Pseudohypoparathyroidism (Target Organ Resistance)

- Signs are round face, short 4th and 5th metacarpal (knuckle-knuckle-dimple-dimple sign) and metatarsals. Pachydactyly, obesity, pseudo webbing of neck, subcutaneous calcification and mental retardation (Fig. 9.23).
- PTH receptor is normal
- Other endocrine glands may be affected.

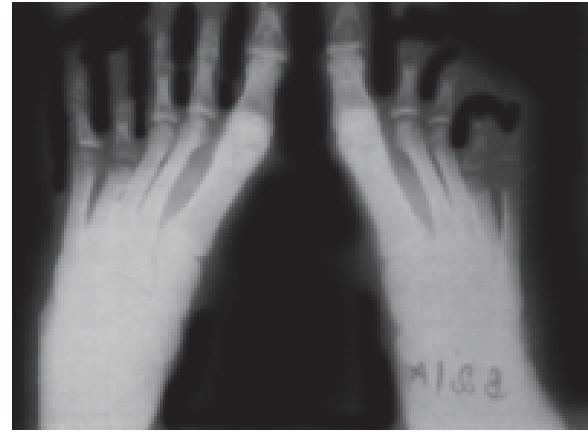

Fig. 9.23: Pseudohypoparathyroidism—short 4th and 5th metatarsals

Lab Diagnosis

Decreased serum calcium and phosphate level with normal parathormone level.



Treatment

Treatment is as for primary hypoparathyroidism.

Pseudopseudohypoparathyroidism

The morphological features of pseudohypoparathyroidism, but normal biochemistry.

Magnesium

Magnesium is distributed 65% in bone and 35% in cells. Its level tends to follow those of calcium and potassium.

Magnesium Deficiency



Clinical Features

Paraesthesiae, fits, tetany, arrhythmias. It can exacerbate digitalis toxicity.



Causes

Severe diarrhoea; diabetic ketoacidosis; alcohol abuse, total parenteral nutrition (monitor level weekly); accompanying hypocalcaemia; accompanying hypokalaemia (especially with diuretics).

Mechanism

- Decreased PTH release
- Decreased PTH action



Treatment

Replace with magnesium salts.

Zinc

Zinc Deficiency

This may occur in parenteral nutrition or with inadequate dietary intake. Rarely it is due to a genetic defect.



Clinical Features

Red, crusted skin lesions especially around nostrils and corners of mouth.

Diagnosis

Therapeutic trial of zinc (plasma levels are unreliable as they may be low, e.g. in infection or trauma, without deficiency).

Adrenal Glands

Anatomy and Physiology

Adrenal gland consists of an inner medulla and an outer cortex. The cortex is subdivided into three zones:

1. Zona glomerulosa—Secreting aldosterone (mineralocorticoid)
2. Zona fasciculata—Secreting cortisol (glucocorticoid)
3. Zona reticularis—Secreting adrenal androgens.

Primary Hyperaldosteronism

This is due to the excess production of aldosterone independent of renin-angiotensin system. This condition must be suspected when patient has evidence of hypertension, hypokalaemia and alkalosis, in the absence of diuretic administration.

Essential Criteria for Diagnosis

1. Diastolic hypertension without oedema
2. Hyposecretion of renin that fails to increase appropriately during volume depletion/upright position
3. Hypersecretion of aldosterone that does not suppress appropriately in response to volume expansion.



Causes

1. Aldosterone producing adrenal adenoma (Conn's syndrome)—60%

2. Hyperplasia of adrenal glands—5%
3. Idiopathic hyperaldosteronism—34%
4. Aldosterone producing carcinoma—1%.



Clinical Features

Patients have hypertension (diastolic BP > 110 mm Hg), features of hypokalaemia (potassium level < 3.5 mEq/litre—muscle weakness, fatigue, cramps, polyuria, polydipsia), impaired glucose tolerance, mild metabolic alkalosis.

There is no oedema.



Investigations

1. Three estimates of potassium should be done with patient taking normal salt intake. Drugs like steroids, diuretics, hypotensives, metoclopramide should be avoided for 4 weeks before the test. Patients have serum potassium less than 3.5 mEq/litre. No tourniquet should be used and blood should be drawn before muscular exercise.
2. Plasma sample for aldosterone, renin, angiotensin, urea and electrolytes should be taken on 3 occasions.
3. CT, MRI, renal venogram for tumour localisation.



Management

1. *Conn's syndrome*—surgery is the definitive treatment (spironolactone 300 mg/24 hours orally for 4 weeks before surgery).
2. *Hyperplasia of adrenals*—dexamethasone 1 mg/24 hours for 4 weeks. If BP remains high, stop dexamethasone and replace with spironolactone. Adrenalectomy is not indicated.

Secondary Hyperaldosteronism

This is due to excess of aldosterone with high renin levels.



Causes

1. Renal artery stenosis
2. Accelerated hypertension
3. Diuretics
4. Hepatic failure
5. Bartter's syndrome (primary hyperreninaemia). It is an inherited disorder presenting as failure to thrive, polyuria, polydipsia. There is no oedema or hypertension. The characteristic feature is



hypokalaemia with metabolic alkalosis. Urinary excretion of sodium and potassium is high.

6. Congestive cardiac failure
7. Nephrotic syndrome
8. Primary rennin secreting tumour
9. Gitslman's syndrome.



Treatment

Correction of hypokalaemia, hyperreninaemia and hyperaldosteronism by indomethacin, amiloride, captopril.

Other drugs used are spiranolactone, eplerenone, and triamterene.

Cushing's Syndrome

Cushing's syndrome comprises of the symptoms and signs associated with excess glucocorticoid levels either due to exogenous administration or endogenous production by adrenal cortex.

Endogenous Cushing's Syndrome can be of 3 types:

1. *Pituitary Cushing's syndrome:* (Cushing's disease): This is caused by a small pituitary tumour (microadenoma). This is common in women of childbearing age.
2. *Adrenal Cushing's syndrome:* This is caused by an adrenal tumour (adenoma, carcinoma, micronodular hyperplasia). Adrenal carcinoma is more common in children.
3. *Ectopic Cushing's syndrome:* This results from autonomous ACTH production from extrapituitary malignancies. It is mostly confined to adult males.

Classification of Cushing's Syndrome

ACTH-dependent

1. Iatrogenic (ACTH therapy)
2. Pituitary-dependent bilateral adrenal hyperplasia
3. Ectopic ACTH syndrome (benign or malignant non-endocrine tumour).

Non-ACTH-dependent

1. Iatrogenic (e.g. prednisolone)
2. Adrenal adenoma
3. Adrenal carcinoma.

Pseudo Cushing's Syndrome

Seen in patients with obesity, chronic alcoholism, and acute illness of any type. These conditions form an important differential diagnosis to Cushing's syndrome.

Clinical Features (Figs 9.24 to 9.26)

Central obesity	(90%)
Hypertension	(85%)
Glucose intolerance	(80%)
Plethoric facies	(80%)
Personality changes	(66%)
Purple striae	(65%)
Hirsutism	(65%)
Oedema	(62%)
Menstrual dysfunction	(60%)
Muscle weakness	(60%)
Decreased libido and impotence	(60%)
Back pain	(60%)
Bruising	(40%)
Osteoporosis	(40%)
Polyuria, polydipsia	} (20%)
Clitoral hypertrophy	
Kidney stones	(15%)
Headache	(10%)
Hyperpigmentation	(5%)

Less common features include mental changes, pigmentation, acne, and hypokalaemic alkalosis. These are common in ectopic ACTH secretion.

Absence of classic signs of Cushing's syndrome in ectopic ACTH tumour is due to the rapid growth and progression of tumour.

Periodic Cushing's Syndrome

There is occurrence of predictable cycles of high and normal cortisol levels, in patients with cushingoid



Fig. 9.24: Cushing's syndrome



Fig. 9.25: Cushing's syndrome—moon face, hirsutism, acne

features and this condition should be suspected when testing fails to demonstrate hypercortisolism.

Evaluation to Localise Tumours

1. *Pituitary Cushing's Syndrome*
 - a. Sellar X-ray—detects 10-15% of tumours
 - b. CT scan detects upto 85% of pituitary microadenomas.
 - c. Petrosal venous sinus sampling for ACTH (Petrosal: Peripheral ACTH >3)
2. *Adrenal Cushing's Syndrome*
 - a. CT scan of adrenal glands
 - b. Abdominal ultrasonography
 - c. MRI
3. *Ectopic Cushing's Syndrome*
 - a. X-ray chest
 - b. CT chest
 - c. MRI
 - d. Cytology.



Management

1. *Pituitary Cushing's Syndrome*
 - a. Trans-sphenoidal adenomectomy or hypophysectomy
 - b. Pituitary X-irradiation
The therapeutic effect of X-irradiation is seen only after 12-18 months. During this period, mitotane in a dose of 3 gm/day is given to control hypercortisolism (medical adrenalectomy).
2. *Adrenal Cushing's Syndrome*
 - a. Unilateral adrenal adenoma—surgical removal; since the contralateral adrenal gland is

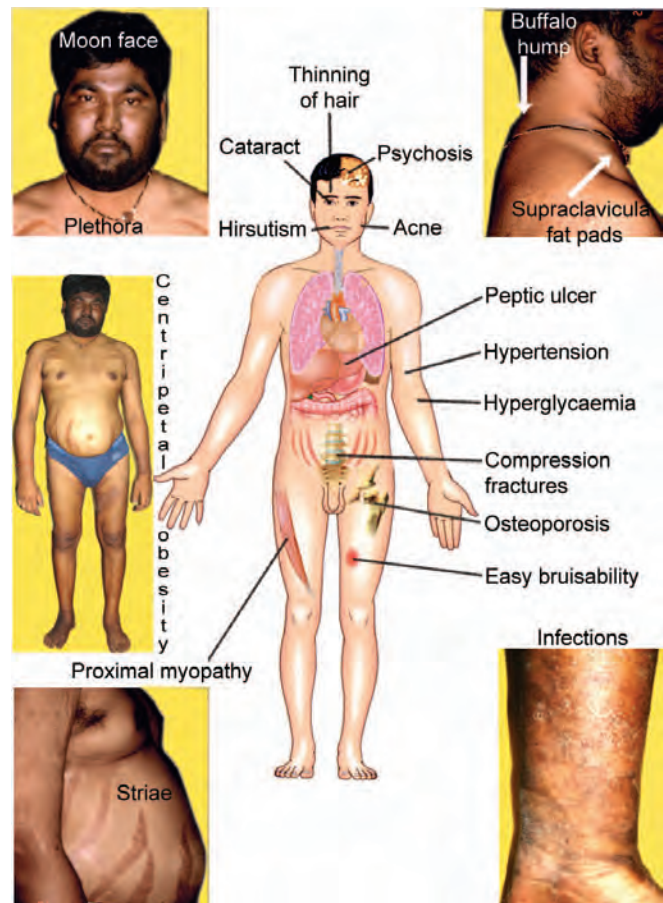

Fig. 9.26: Clinical features in Cushing's syndrome

suppressed, glucocorticoid replacement is necessary for several months until adrenal function returns.

- b. Adrenal carcinoma—surgery is the treatment of choice; in inoperable cases mitotane can be used in a dose of 250 mg qid upto 2 to 4 gm/day. MRI can be used for prognostic evaluation.
3. *Ectopic Cushing's Syndrome*
 - a. Surgery is the treatment of choice. Adrenalectomy can be considered in cases of indolent yet inoperable tumours such as medullary carcinomas of the thyroid.
 - b. Adrenal enzyme inhibitors for reducing hypercortisolism in ectopic ACTH syndrome.
 - i. Metyrapone (11-hydroxylase inhibitor) 250-500 mg tid.
 - ii. Aminoglutethimide—this blocks the conversion of cholesterol to delta-5-pregnenolone, in a dose of 250 mg qid upto 2 g daily.



- iii. Adrenolytic agents—*mitotane (medical adrenalectomy)* can be used in addition to the enzyme inhibitors. It is contraindicated in pregnancy. Mitotane has a long half-life and can be detected in adipose tissue even after 2 years and hence it must be avoided in fertile females who desire pregnancy later in life. It is a teratogen and induces abortion.
 - iv. Ketoconazole—this blocks steroidogenesis at several levels (esp. 20-22 desmolase catalysing the conversion of cholesterol to pregnenolone). The dose ranges from 400-2000 mg/day. Therapy can be combined with other agents mentioned above.
 - v. Mifepristone is another treatment option.
4. **Bilateral adrenal hyperplasia: ACTH/CRH**
 Pituitary source – Surgery
 Extra-pituitary source – Surgery
 Inoperable – Medical adrenalectomy
 Unknown source – Bilateral adrenalectomy followed by life-long glucomineralocorticoid replacement.

- 2. A destructive process at the hypothalamic-pituitary level, leading to CRH or ACTH deficiency or both.
- 3. Long-term suppression of the hypothalamo-pituitary-adrenal (HPA) axis by exogenous or endogenous glucocorticoids followed by inappropriate withdrawal.



Causes of Addison's Disease

1. Primary

- A. *Anatomic destruction*
 - a. Idiopathic atrophy—65%
(Autoimmune adrenalitis)
Sporadic
Type I polyglandular autoimmune syndrome
Type II polyglandular autoimmune syndrome
 - b. Surgical ablation
 - c. Infection
 - i. Bacterial Tuberculosis (20%)
 Meningococemia
 (Waterhouse-Friderichsen syndrome)
 - ii. Fungal Histoplasmosis
 Cryptococcosis
 Coccidioidomycosis
 - iii. Viral HIV
 CMV

Adrenal Insufficiency

Adrenal insufficiency can be caused by:

- 1. A primary disease at the, adrenal level, involving destruction of over 90% of the steroid-secreting cortex (Addison's disease).

Evaluation to Find out if the Patient has Cushing's Syndrome or not

Test	Abnormality in Cushing's syndrome
1. Circadian rhythm of plasma cortisol (8.00 and 24.00 samples)	Loss of rhythm
2. Low dose dexamethasone suppression: <ul style="list-style-type: none"> a. 1.5 mg at midnight and 9 am plasma cortisol next day b. 0.5 mg 6-hourly for 48 hours and plasma cortisol at 48 hours 	> 180 nmol/l > 180 nmol/l
3. Urinary free cortisol 24-hour excretion or overnight excretion	Elevated (value depends on method used); > 140 mmol/L diagnostic
4. Insulin-induced hypoglycaemia	No rise in plasma cortisol

Evaluation to Find out the Cause of Cushing's Syndrome

Test	Pituitary dependent	Ectopic ACTH	Adrenal tumour
1. Plasma ACTH 08.00	N (10-80 ng/l) or ↑ (80-300 ng/l)	↑ or ↑↑ (300 ng/l)	Undetectable
2. Metyrapone 750 mg 4-hourly × 6 doses: measure 11-deoxycortisol at 24.00	↑↑	↑	→↑
3. High dose dexamethasone 2 mg 6-hourly for 48 hours: Plasma cortisol 48 hours	↓	→	→
4. Plasma K ⁺	N	< 3.5 mmol/l	N
5. Corticotrophin-releasing factor (1 µg/kg body weight) and measure plasma ACTH and cortisol over 3 hours	↑	→	→

- d. Inflammation Sarcoidosis
 e. Haemorrhage Breech delivery
 Anticoagulant therapy
 f. Invasion Secondaries (breast/lung)

B. *Metabolic*

- a. Congenital adrenal hyperplasia and hypoplasia
 b. Drugs Enzyme inhibitors (ketoconazole, aminoglutethimide)
 Metyrapone, Etomidate
 Cytotoxic (mitotane)
 c. Haemochromatosis

C. *ACTH blocking antibody (IgG)*D. *ACTH receptor gene mutation.*

2. Secondary Adrenal Insufficiency

- Tumours
 Pituitary tumour
 Craniopharyngioma
 Tumour of the third ventricle
- Pituitary infarction and haemorrhage
 Postpartum necrosis (Sheehan's syndrome)
 Haemorrhage in tumours
- Granulomatous diseases
 Sarcoidosis
- Following hypophysectomy
- Steroid withdrawal
- Hypopituitarism
- Suppression of hypothalamo-pituitary axis by exogenous or endogenous steroids.



Clinical Features (Fig. 9.27)

1. *Due to glucocorticoid insufficiency*

Weight loss	(100%)
Malaise	(100%)
Weakness	(100%)
Anorexia	(100%)
Nausea	(50%)
Vomiting	(50%)
Gastrointestinal (diarrhoea or constipation in 50%)	
Postural hypotension	(this is present in almost all patients and BP should be checked after standing for 1 minute. Systolic pressure should be < 100 mm Hg)

Acute abdominal pain

Hypoglycaemia

2. *Due to mineralocorticoid insufficiency*

Hypotension

Hyperkalaemia

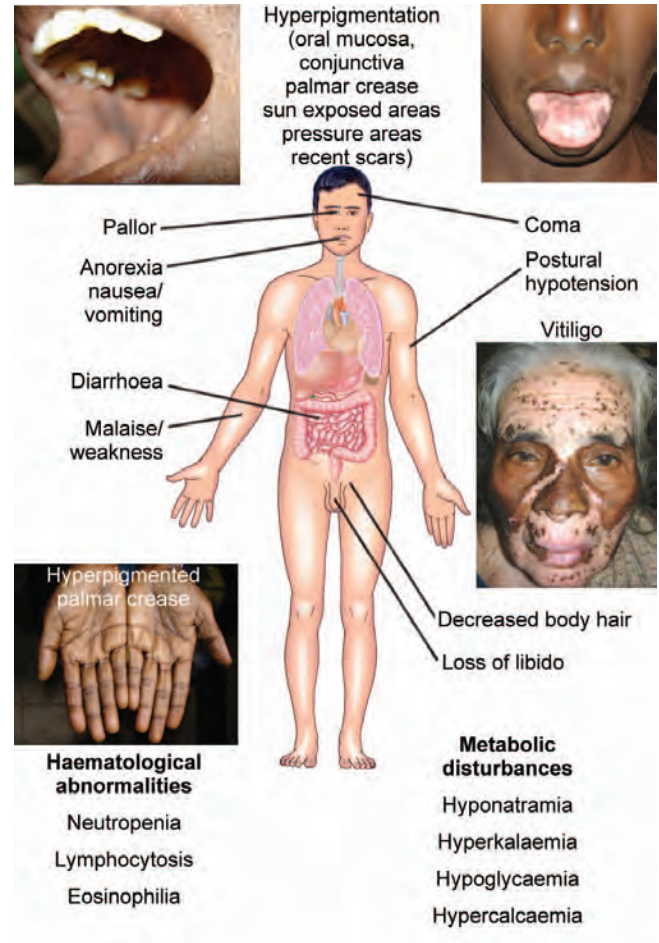

Fig. 9.27: Clinical features in Addison's disease

3. *Due to increased ACTH secretion*

Pigmentation is seen in

- Sun exposed areas
- Pressure areas, e.g. elbows, knees
- Palmar creases, knuckles
- Mucous membranes
- Conjunctiva
- Recent scars

4. *Due to loss of adrenal androgen*

Decreased body hair especially in females.

Hyperpigmentation, adrenal calcification and vitiligo are seen only in primary hypoadrenalism. Pigmentation is not seen in secondary hypoadrenalism.

Associated Other Autoimmune Disease

1. Hashimoto's thyroiditis
2. Primary atrophic hypothyroidism
3. Pernicious anaemia
4. Type 1 diabetes mellitus
5. Primary ovarian failure
6. Hypoparathyroidism



7. Mucocutaneous candidiasis
8. Vitiligo

Lab Investigations

1. Plasma electrolytes—sodium is low, potassium is high, plasma urea is raised.
2. Blood glucose—may be low in severe adrenal insufficiency
3. Eosinophilia, lymphocytosis and normocytic anaemia.

Special Tests

1. ACTH Stimulation Test (Cosyntropin Test)

Cosyntropin is a potent stimulator of cortisol and mineralocorticoids.

Procedure

1. Draw blood for baseline serum cortisol, aldosterone and ACTH at 8.00 am.
2. 0.25 mg cosyntropin IV or IM should be given.
3. Obtain blood samples for cortisol and aldosterone 30 min—60 mins following its administration.
Normal Plasma cortisol > 495 nmol/lit
Primary—No change
Secondary—Subnormal ↑

2. Metyrapone Test

This test is used to confirm diagnosis of adrenal insufficiency and useful especially when secondary causes are suspected.

Metyrapone is an inhibitor of an enzyme required for cortisol synthesis and so its administration leads to a fall in the level of cortisol, rise in ACTH level and rise in 11-deoxycortisol (immediate precursor of cortisol).

Procedure

Metyrapone is given as a single dose of 2-3 g (to be given at midnight with snack). ACTH, serum cortisol and 11-deoxycortisol are measured at 8.00 am the following day.

Interpretation

Type of adrenal insufficiency	ACTH	Serum cortisol	11-deoxy-cortisol
Normal	↑	↓ < 5 µg/dl	↑ > 7 µg/dl
Primary			↑ < 5 µg/dl
Secondary			↑ < 5 µg/dl

*If ACTH test is blunted, then the metyrapone test is unnecessary.

3. Plasma Renin Activity

The values are always high in primary adrenal insufficiency since plasma aldosterone level is low. In secondary adrenal insufficiency plasma renin activity may be normal as serum aldosterone levels are normal.



Management

1. Primary adrenal insufficiency requires replacement with both mineralocorticoids and glucocorticoids.
 - a. Glucocorticoid replacement with either
 - i. Prednisolone 5 mg in the morning and 2.5 mg in the evening.
 - or
 - ii. Hydrocortisone (cortisol) 20 mg in the morning and 10 mg in the evening.
 - or
 - iii. Cortisone acetate 25 mg in the morning and 12.5 mg in the evening.

Increased doses are needed in patients who are obese, and also for patients who are on barbiturates, phenytoin or rifampicin as they enhance metabolism of steroids. Steroid doses should be lowered in patients with liver disease, diabetes mellitus, peptic ulcer or hypertension and also in old age.

Appropriate weight gain and the regression of pigmentation are reliable indices for adequate steroid replacement.

- b. Mineralocorticoid replacement is done with fludrocortisone, a synthetic product, in a dose of 0.05-0.3 mg with adequate salt intake. The dose can be adjusted according to the response.
 - c. Patient should be educated regarding:
 - i. Adjustment of steroid dose for mild illness (double dose in fever)
 - ii. Carrying a card or wearing a bracelet with the name of the disease they are suffering from.
 - iii. Administration of 100 mg of hydrocortisone 6th hourly for 24 hours prior and 50 mg IM 6th hourly thereafter.
 - iv. In case of gastroenteritis, patients must have parenteral hydrocortisone if oral intake is not possible.
 - d. Sex hormone replacement due to associated primary gonadal insufficiency is required in selected patients.
2. Secondary adrenal insufficiency does not require mineralocorticoid replacement. Other tropic hormones of anterior pituitary should be replaced.

Interpretation of the Test

Cause of adrenal insufficiency	ACTH (Baseline level)	Serum cortisol	Aldosterone
1. Primary	High	Baseline level ↓ and no ↑ after cosyntropin	Baseline aldosterone level ↓ and no ↑ with cosyntropin
2. Secondary	Low or normal	Baseline level ↓ and increases after cosyntropin	Baseline level ↓ or normal and ↑ aldosterone level 30 mins after cosyntropin

- HPA suppression can be minimised by giving single morning daily dose of short acting steroids like hydrocortisone and prednisolone or by doubling the total daily dose and giving it on alternate days. This does not hold true for long acting steroids like dexamethasone or betamethasone.
- Tapering of glucocorticoids: Once prednisolone is reduced to 5 mg/day, switch over to hydrocortisone 20-25 mg every morning. The short half-life of hydrocortisone gives time for HPA system to recover. 8 am plasma cortisol should be measured monthly and if it less than 10 µg/dl, it indicates continued HPA suppression. If it is more than 10 µg/dl, hydrocortisone can be withdrawn.

Similarly, an ACTH test can be performed. Following ACTH if plasma cortisol increases > 20 µg/dl, it indicates a recovered HPA axis. If 8 am cortisol is greater than 10 µg/dl, but the response to ACTH is still blunted, steroid coverage for major illness will be necessary as long as the ACTH test yields a subnormal response.

Adrenal Crisis



Causes

- Idiopathic adrenal vein thrombosis
- Adrenal adenoma
- Adrenal infarction
- Pregnancy
- Anticoagulants

It is a medical emergency and may be the first manifestation of hypoadrenalism.

It occurs in patients with chronic adrenal insufficiency often precipitated by infection, trauma, surgery or bilateral adrenal haemorrhage (Waterhouse-Friderichsen syndrome).



Clinical Features

Fever, dehydration, nausea, vomiting, hypotension with electrolyte imbalance (hyperkalaemia, hyponatraemia and hypercalcaemia occasionally).



Management

- IV fluids (2-3 litres of 5% dextrose saline) as quickly as possible and monitor fluid balance with central venous pressure recording.
- Hydrocortisone 100 mg IV is given initially and it should be repeated 100 mg 6th hourly till the patient stabilises.
- Treatment of underlying precipitating cause.
- Taper steroid to maintenance dose.
- Mineralocorticoid replacement with fludrocortisone 0.1 mg orally daily after stopping saline infusion.
 - No need for mineralocorticoid if hydrocortisone > 100 mg/day is used.

Phaeochromocytoma

It is a relatively rare benign tumour arising from chromaffin cells of the sympathoadrenal system. It is a rare cause of hypertension accounting for < 0.1% of patients with sustained diastolic hypertension.

The majority of pheochromocytoma arise from adrenal medulla (90%). Other sites of origin are organ of Zuckerkandl, aortic bifurcation (8%), rarely from extra adrenal sites in the abdomen, chest (< 2%), neck (< 0.1%) and left atrial region.

It occurs at all ages with a peak incidence in the 3rd and 4th decade. There is equal frequency in both sexes (in adults). 90% of the tumours are benign and 90% are unilateral.

Multiple tumours (adrenal and extra adrenal) are common in children than adults.

It is called as 10% tumour because, 10% are bilateral, 10% malignant, 10% extra-adrenal, 10% familial, 10% multiple and 10% occur in children.

- Extra-adrenal pheochromocytoma does not secrete epinephrine.

Pathophysiology

They are encapsulated, vascular tumours of about 5 cm in diameter and weigh < 70 gm. There is no correlation between the size of the tumour and rise in plasma catecholamine levels or the clinical features. Most



phaeochromocytomas secrete both epinephrine and norepinephrine (predominant). Some tumours secrete dopamine.

Epinephrine is predominantly secreted in association with multiple endocrine neoplasia.



Clinical Features

Symptomatic episodes may occur as often as 25-30 times/day or as infrequently as once every few months. The duration of attack is usually less than one hour but may extend to as long as one week.

Common Symptoms

Headache	(90%)
Sweating	(60%)
Palpitations	(70%)
Nervousness	(40%)
Weight loss	(40%)
Nausea and vomiting	(30%)
Chest and abdominal pain	(30%)

Anxiety and fear of death (angor animi) occur in majority of the patients.

Signs

Patient may present with paroxysmal or persistent hypertension or postural hypotension. Hyperglycaemia or impaired glucose tolerance is common. Pallor, tremor, Raynaud's phenomenon and manifestations of coexisting diseases (GIT ganglioneuromatosis, neurofibromas, Cushing's syndrome) can also be present.

Attacks are precipitated by pressure in the vicinity of the tumour, anxiety, exercise, micturition, alcohol ingestion, general anaesthetics, beta blockers, nicotine, phenothiazines, morphine, metoclopramide, hydralazine, droperidol and atropine.

Syndromes Associated with Pheochromocytoma

Multiple endocrine neoplasia (MEN)	
MEN-I	Hyperparathyroidism Hyperpituitarism Zollinger-Ellison syndrome Hyperadrenalism (cortex) Hyperthyroidism Ectopic hyperinsulinism, hyperglucagonism and increased release of human pancreatic polypeptide Pheochromocytoma (rarely)
MEN-II	Medullary carcinoma of thyroid Adenoma or hyperplasia of parathyroid

Bilateral adrenal hyperplasia

Pheochromocytoma

MEN-III or II B	Medullary carcinoma of thyroid Mucosal neuromas Thickened corneal nerves (slit lamp examination) GIT ganglioneuromas Marfanoid habitus Pheochromocytoma.
-----------------	---

Other Associated Syndromes

- Neurofibroma (NF) with cafe-au-lait spots (von Recklinghausen's disease NF, pheochromocytoma and somatostatin rich duodenal carcinoid tumour)
- von Hippel-Lindau disease (cerebroretinal hemangioblastoma)
- Acromegaly



Investigations

1. *Single voided (spot) urinary metanephrine*: This correlates with 24 hours urine test and is particularly useful when urine is collected following an attack.
2. *24 hours urine test for total metanephrine*: This is the most reliable screening test. However, false positive tests are common in patients taking chlorpromazine, benzodiazepines or sympathomimetics.

Normal metanephrine levels in urine

Total < 1.3 mg/24 hours

Normetanephrine < 0.9

Metanephrine < 0.4

3. 24 hours urinary free catecholamines (epinephrine, norepinephrine or dopamine).

Normal values

Total < 100 µg/24 hours

Norepinephrine < 75 µg/24 hours

Epinephrine < 25 µg/24 hours

4. Plasma catecholamine levels before and after the attack.

Normal value (Plasma)

Norepinephrine < 500 pg/ml

Epinephrine < 100 pg/ml

Diagnostic value

> 1500 pg/ml

> 300 pg/ml

5. Vanillylmandelic acid levels in urine: Normally present upto 1.5-6.5 mg/day; > 8 mg/day is diagnostic. It is the least reliable of all tests.
6. Tumour localisation by CT scan, Meta-131-Iodo Benzyl Guanidine (MIBG) scintigraphy or MRI. Central venous blood sampling can assist in localisation of tumour when all other measures fail (Figs 9.28 to 9.31).
7. DOPA - PET scan.
8. Somatostatin scintigraphy.

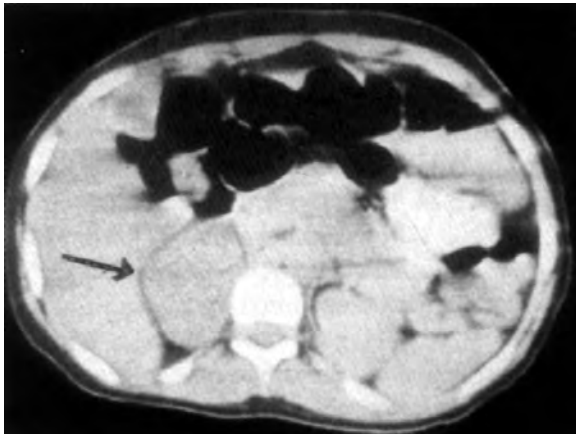

Fig. 9.28: CT abdomen—right adrenal mass

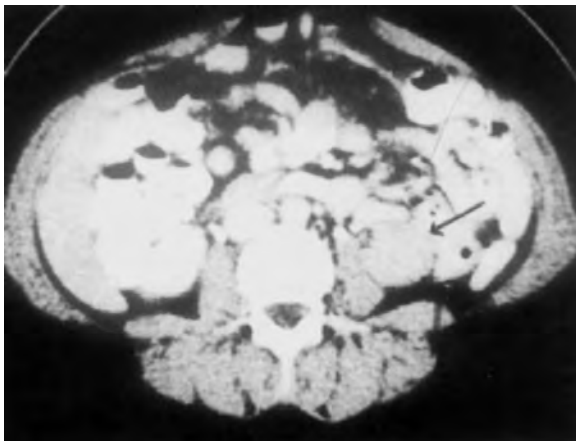

Fig. 9.29: CT abdomen—left extra-adrenal paraganglioma



Fig. 9.30: MRI abdomen left extra-adrenal paraganglioma



Management

Acute medical therapy for severe hypertension.

- a. Bedrest with head end of the bed elevated.

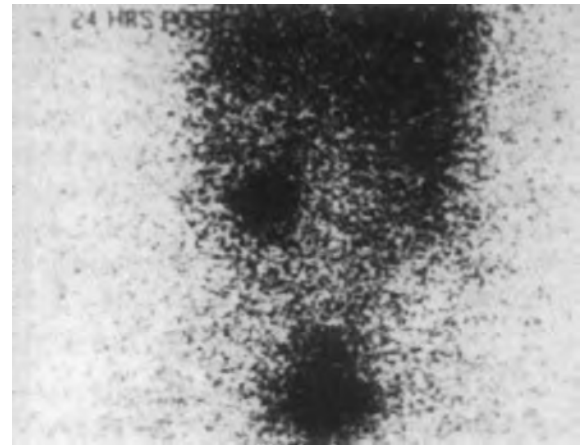

Fig. 9.31: MIGB scan—confirms the extra-adrenal paraganglioma

- b. Alpha receptor blocker—phentolamine 2.5 mg IV every 5 minutes until BP is stabilized.
- c. Sodium nitroprusside (100 mg in 500 ml dextrose as IV infusion).
- d. Beta blocker to control arrhythmias (only after administration of alpha blocker).
- e. Intravascular volume replacement may be necessary.
- f. Avoid all precipitating agents to prevent tachyarrhythmias.

Other Drugs for Control of Hypertension

Prolonged control of hypertension can be advised with phenoxybenzamine (long acting alpha blocker) 10 mg bd upto a maximum of 200 mg/day.

Prazosin can be used in a dose of 1-2 mg bd or tds. Beta blocker can be added only after adequate alpha blockade. Labetalol can also be tried.

Surgical Treatment

This is the definitive treatment for phaeochromocytoma. However, pre-operative stabilisation is done with phenoxybenzamine 10-20 mg 6th hourly for 6 weeks before surgery for restoration of intravascular volume.

Pre-operative and postoperative rise in BP can be controlled with phentolamine or nitroprusside. Postoperative hypotension and hypoglycaemia are common. This is managed by norepinephrine and IV dextrose. Failure of fall in BP after surgery indicates presence of additional tumour. Postoperative fall in BP is avoided by hydrating the patient well before operation along with adequate alpha blockade.

Inoperable cases or those tumours with metastasis can be treated with metyrosine (tyrosine hydroxylase inhibitor).



Prognosis

- 5-year survival for benign tumours is 85%
- 75% become normotensive after surgery
- 5-year survival for malignant tumours is < 50%.

Sexual Disorders

Ambiguous Genitalia

The newborn with ambiguous genitalia should be considered a medical emergency as there may be immediate physiologic problems such as salt loss or shock and also since there is an urgent necessity to assign a sex to the child.

Structural change into an early gonad begins in the fourth post-fertilisation week with the appearance of so-called sex cords.

In the normal XY male, a specific gene on the Y chromosome, is believed to be the switch that turns on other genes in the indifferent gonad, directing the organisation of the sex cords into a testicular structure. In the XX female, the absence of the Y chromosome organises the sex cords into an ovarian structure.

In the male, testicular organogenesis is rapid and secretes testosterone and anti-mullerian hormone. These hormones then allow development of the wolffian duct structures (epididymis, ductus deferens, seminal vesicle, and common ejaculatory duct) and the male external genitalia.

In the female, the absence of anti-mullerian hormone, and low circulating testosterone level allows the development of mullerian duct structures (fallopian tubes and uterus) and the female external genitalia.

Contributing Factors

1. *Congenital adrenal hyperplasia*: This is caused by various enzymatic defects in the steroid hormone pathway in the adrenal gland, inherited as an autosomal recessive trait.

C-21 hydroxylase deficiency is the most common, resulting in virilisation of the female infants and cortisol deficiency, with or without associated salt-losing tendency.

2. *Iatrogenic virilisation*: Virilisation of the female neonate may be seen in children of mothers who had ingested virilising agents such as progestogens (norethindrone) in the first trimester of antenatal period.

3. *True hermaphrodite*: Embryonic events of gonadal differentiation are independent of one another and proceed independently in each gonad. Thus, gonadal histology can differ between sides, and even within a

single gonadal ridge more than one type of gonad can develop as occurs in a hermaphrodite with one of bilateral ovotestes or one ovary and a contralateral testis. The karyotype may be 46XX, 46XY, or any mosaic (45X0/46XX/47 XXY).



Management

1. Reconstructive surgery (between 18 and 24 months of age).
2. Correction of underlying disorder (steroid replacement in congenital adrenal hyperplasia).

Premature Sexual Developmental Disorders

Precocious Puberty in Females

This is said to occur when there is development of breasts, pubic hair and accelerated linear growth rate in a girl before age of 8 years.



Causes of Precocious Puberty in Females

- I. Pituitary gonadotrophin secretion (true or central precocity)
 - a. Idiopathic (sporadic and familial)
 - b. CNS abnormalities
 1. Hypothalamic hamartomas
 2. Space-occupying lesions (astrocytomas, pituitary adenomas and craniopharyngiomas)
 3. Cerebral damage (irradiation, surgery, trauma, encephalitis, meningitis)
 4. Hydrocephalus
 5. Brain abscess
 6. Granulomatous lesion.
 - c. Occasional consequence of chronic primary hypothyroidism
- II. Ovarian steroid secretion (precocious pseudopuberty)
 - a. Ovarian tumours (granulosa cell, theca cell, or luteomas)
 - b. Adrenal adenomas or carcinomas
 - c. Exogenous sex steroids
 - d. McCune-Albright syndrome (autonomous ovarian hormone secretion)
 - e. Ovarian cysts.

Principles of Management

1. Psychologic preparation and reassurance.
2. Treatment of underlying cause (removal of CNS, ovarian, adrenal, or ectopic gonadotropin-producing tumour).

3. Replacement of thyroid hormones (in chronic primary hypothyroidism).
4. In true sexual precocity, treatment is aimed at suppressing the underlying episodic release of gonadotropins.

Precocious Puberty in Males

Puberty is considered precocious if secondary sexual characteristics occur before the age of 9 years in boys.



Causes of Precocious Puberty in Males

1. Central precocious puberty
 - a. Idiopathic
 - b. CNS disorders (tumours, hypothalamic hamartomas, infections, hydrocephalus, trauma)
 - c. Juvenile hypothyroidism.
2. Incomplete precocious puberty
 - a. Virilizing congenital adrenal hyperplasia
 - b. Adrenocortical carcinoma
 - c. Interstitial cell tumours of the testes
 - d. HCG-secreting tumours (hepatoblastomas, retroperitoneal tumours, and germ cell tumours).
3. Androgen therapy.



Treatment

- Precocious puberty in males results in attenuation of adult stature depending on the age of onset.
- Administration of long acting gonadotrophin releasing hormone analogue suppresses the secretion of pituitary gonadotrophins and helps in the boy attaining normal stature.
- Treatment of underlying disorder (congenital adrenal hyperplasia with steroids).

Gynaecomastia

It is the presence of an abnormal amount of breast tissue in males. This occurs due to an increase in the oestrogen/androgen ratio. It is therefore seen in syndromes of androgen deficiency (Klinefelter's, Kallman's) or from oestrogen excess (oestrogen secreting testicular tumours, decompensated liver disease).



Causes

1. Physiologic (newborn or pubertal)
2. Androgen deficiency
 - a. Klinefelter's syndrome
 - b. Kallman's syndrome
 - c. Congenital anorchia

- d. Androgen resistance
- e. Defects in testosterone biosynthesis
- f. Acquired testicular failure as in viral orchitis
3. Oestrogen-secreting tumours
4. HCG-secreting tumours
5. Drugs (spironolactone, cimetidine, digitalis, phenothiazines, antidepressants)
6. Decompensated liver disease
7. Trauma or recovery from severe illness
8. Idiopathic.



Treatment

- Patients with pubertal gynaecomastia must be reassured (condition may persist for 2 or 3 years).
- If it does not subside, then percutaneous dihydrotestosterone (125 mg twice daily for 1-4 months) or oral testosterone (150 mg tid for 2-6 months) may be tried.
- Alternatively surgical removal by liposuction of the glandular and adipose tissue may be done.
- Indications for surgery
 - psychological and/or
 - cosmetic problems,
 - continued growth or tenderness
 - suspected malignancy.

Hirsutism and Virilism

This implies increased hair growth in women, in a male pattern of distribution. It is seen in 10% of women and is usually benign.



Causes of Hirsutism

1. Familial
2. Idiopathic
3. Ovarian
 - a. Polycystic ovaries (hilus-cell hyperplasia)
 - b. Tumour (arrhenoblastoma, hilus cell, adrenal rest cell)
4. Adrenal
 - a. Congenital adrenal hyperplasia
 - b. Noncongenital adrenal hyperplasia (Cushing's)
 - c. Tumour (virilising carcinoma or adenoma).

In the presence of hirsutism, if menstruation is normal, there is almost certainly no increased testosterone production, but if menstruation is abnormal, the cause is usually polycystic ovary syndrome (Stein-Leventhal syndrome), which comprises of hirsutism, oligomenorrhoea, obesity and infertility.



Management

1. If there is no underlying cause, treatment is by local removal of unwanted hair by depilation with wax or creams, or electrolysis, or with bleaching with 1:10 hydrogen peroxide, or by shaving.
2. Treatment of the underlying cause if present (e.g. clomiphene therapy for polycystic ovary syndrome).

Virilism

This is characterised by amenorrhoea, clitorimegaly, deep male voice, temporal hair recession and hirsutism.

It is rare and needs investigation for presence of underlying androgen secreting adrenal or ovarian tumours.

Diabetes Mellitus (DM)

Diabetes mellitus is one of the most common endocrine disorders. It is a disorder of metabolism of carbohydrate, protein and fat due to absolute or relative deficiency of insulin secretion and with varying degrees of insulin resistance. This metabolic disorder results in long-term disease specific microangiopathy (nephropathy, retinopathy, neuropathy) and aggravation of macroangiopathy.

Characteristics of Endocrine Cells of Islets of Langerhans

Cell type	Percentage of islet cells	Hormonal content
β	60-80	Insulin
α	15-20	Glucagon
δ	5-10	Somatostatin
PP	15-20	Pancreatic polypeptide
δ_1	< 1	Vasoactive intestinal polypeptide
EC	< 1	Substance P, serotonin
GI	< 1	Gastrin

Insulin Time Table

Year of identification	Insulin products
1921	Pancreatic extracts showed blood sugar lowering effect (Banting and Best)
1922	Insulin was first used in human
1923	Production of insulin from animal sources
1925	First international insulin unit defined
1926	Crystallized amorphous insulin was made to give stability
1936	Protamine zinc insulin was identified

1939	Globin insulin with shorter action identified
1950	NPH (neutral protamine Hagedorn) was identified
1951	Lente insulins were developed
1955	Structure of insulin delineated
1960	Radioimmunoassay of insulin was made available
1967	Proinsulin discovered
1971	Insulin receptor defined
1972	U-100 insulin introduced to promote better accuracy in administration
1973	Small-dose IV insulin for DKA emerges
1976	C-peptide becomes a clinical tool
1977	Insulin gene cloned
1978	Purified single-peak pork insulins introduced (mono component insulin)
1979	Open loop insulin delivery system identified
1981	Insulin-receptor kinase activity described
1982	Recombinant DNA insulin becomes available (human insulin)
1999	Insulin analogue

Aetiologic Classification of Diabetes Mellitus

I. Type 1 Diabetes mellitus (β cell destruction, usually leading to absolute insulin deficiency)

- A. Immune mediated
- B. Idiopathic.

II. Type 2 Diabetes mellitus (May range from predominantly insulin resistance with relative insulin deficiency to a predominant secretory defect with insulin resistance).

III. Other specific types

- A. Genetic defects of β cell function
 1. MODY 1—HNF* 4 α mutation on chromosome 20.
 2. MODY 2—Glucokinase gene mutation on chromosome 7
 3. MODY 3—HNF 1 α , mutation on chromosome 12
 4. MODY 4—Insulin promoter factor 1 mutation on chromosome 13
 5. MODY 5—HNF 1 β , mutation on chromosome 17
 6. Mitochondrial dysfunction—tRNA mutation.
 7. Mutant insulin/proinsulin—Insulin gene mutation on chromosome 11
* HNF—Hepatocyte nuclear factor
- B. Genetic defects in insulin action
 1. Type A insulin resistance
 2. Leprechaunism
 3. Rabson-Mendelhall syndrome
 4. Lipotrophic diabetes
 5. Others
- C. Diseases of exocrine pancreas
 1. Pancreatitis
 2. Trauma, pancreatectomy

3. Neoplasia
 4. Cystic fibrosis
 5. Hemochromatosis
 6. Fibrocalculous pancreatopathy
 7. Others
- D. Endocrinopathies
1. Acromegaly
 2. Cushing's syndrome
 3. Glucagonoma
 4. Pheochromocytoma
 5. Hyperthyroidism
 6. Somatostatinoma
 7. Aldosteronoma
 8. Others
- E. Drugs or chemical induced
1. Pentamidine
 2. Nicotinic acid
 3. Glucocorticoids
 4. Thyroid hormones
 5. Diazoxide
 6. β agonist
 7. Thiazides
 8. Phenytoin
 9. α Interferon
 10. Others
- F. Infections
1. Congenital rubella
 2. CMV
 3. Others
- G. Uncommon forms of immune mediated diabetes
1. Stiffman's syndrome
 2. Anti-insulin receptor antibody
 3. Others
- H. Other genetic syndromes associated with diabetes
1. Down's syndrome
 2. Klinefelter's syndrome
 3. Turner's syndrome
 4. Wolfram's syndrome
 5. Friedreich's ataxia
 6. Huntington's chorea
 7. Laurence-Moon-Biedl syndrome
 8. Myotonic dystrophy
 9. Porphyria
 10. Prader-Willi syndrome
 11. Others

IV. Gestational diabetes mellitus

Risk Factors for Type 2 Diabetes Mellitus (Statistical Risk Disease)

- Family history of diabetes
- Obesity
- Age > 42 years
- Race/ethnicity (Asian American, African American)
- Previously identified IFG or IGT
- H/o GDM or delivery of baby over 4.5 kg
- Hypertension (BP > 140/90)
- HDL < 35 mg% and/or Triglyceride > 250 mg%
- Polycystic ovary syndrome
- Stress induced hyperglycaemia as in
 - Infection
 - Myocardial infarction
 - Trauma
 - Pregnancy
 - Stroke
 - Emotional stress
 - Drugs (glucocorticoids, oestrogens, sympathomimetics, nicotinic acid).

Approximate Empirical Risk of Development of Type I DM upto the Age of 25 Years

First degree relative with Type I DM	Risk of Type I DM (%)
Father	2.5
Mother	1.5
Both parents	15-20
Mother and sibling	13
Sibling	3
Monozygotic twin	40

Pathogenesis

- a. *Genetic predisposition*: Diabetogenic genes are present on the short arm of chromosome 6 (as a part of or in close proximity to MHC)
- b. *Environmental triggers*:
 - i. Viral infection (coxsackie B₄, EMC virus, rubella virus, CMV, mumps virus, hepatitis virus, rotavirus, EB virus)
 - ii. Toxins (alloxan, streptozotocin, pentamidine isothiocyante).

Viruses and chemicals have direct effect on β cells and therefore represent causative factor that initiates the autoimmune process against these cells. The alternative hypothesis is that these agents potentiate β cell destructive process which is genetically determined or initiated by environmental factors.

- c. *Immune mechanism*: DM is considered as an autoimmune disorder when environmental factors are not involved. It is also associated with other autoimmune disorders. It may be due to the presentation of diabetogenic peptide to the immune system.



Polyendocrine Autoimmune Syndromes

Type I	Type II
No HLA association	HLA-DR ₃ and DR ₄
Autosomal recessive	Autosomal dominant
Mucocutaneous candidiasis	
Hypoparathyroidism	
Addison's disease	Addison's disease
Graves' disease	
Thyroiditis	Thyroiditis
Type 1 diabetes (5%)	Type 1 diabetes (50%)
Vitiligo	Vitiligo
Hepatitis	
Malabsorption	Coeliac disease
	Myasthenia gravis
Pernicious anaemia	Pernicious anaemia
	Serositis
	Parkinson's disease

Relationship between DM and HLA System

Ninety-five per cent of type 1 DM are HLA DR₃ or DR₄ or DR₃/DR₄ positive; HLA DR₂ confers protection against the development of type 1 diabetes.

Insulinitis/Isletitis

'T' cell mediated immune destruction occurs in islet cells with infiltration of mononuclear cells. Lymphocytes, NK cells, macrophages, monocytes are involved in the pathogenesis by a cytokine mediated mechanism involving IFN- γ , TNF, IL-1 and lymphotoxin.

Circulating antibodies to β cells can be detected several years before or at the time of onset of Type 1 DM, the antibodies being islet cell antibodies (ICA) and insulin autoantibodies (IAA). These are immune markers for identifying β cell destruction in Type 1 DM.

Immune intervention trials have been carried out in Type 1 DM in the early stage with azathioprine alone or in combination with glucocorticoids and cyclosporin or insulin. This trial has proved that the disease process can be effectively halted by preventing further destruction of β cells.

However, this intervention must be done in the prediabetic state, in high risk individuals from birth, by genetic screening and periodically measuring circulating antibodies with periodic assessment of β cell function.



Clinical Features

Patient is usually thin built and wasted. Polyuria, polydipsia, polyphagia, weight loss, fatigue and weakness are major symptoms; patient may present with diabetic ketosis (air hunger, Kussmaul's respiration, acetone odour of breath, dehydration, vomiting, abdominal pain, etc.).

Diagnosis

1. Symptoms of diabetes plus Random blood glucose > 200 mg% (11.1 mmol/l)
2. Fasting plasma glucose > 126 mg% (7 mmol/l)
3. Two hour plasma glucose > 200 mg% during an oral glucose tolerance test.

In the absence of unequivocal hyperglycaemia and acute metabolic decompensations these criteria should be confirmed by repeat testing on a different day.

Principles of the test: Give 150-200 gm of carbohydrate daily for 3 days prior to the test. Overnight fast is advocated the day before the test. Patient should take 75 g of glucose dissolved in 300 ml of water; Serum glucose should be measured every half an hour for 2 hours.

4. Islet cell antibodies are positive in about 80% of the patients before administration of insulin.
5. *C-Peptide:* 24 hours urine collection is recommended.

In normal persons 'c' peptide level	> 30 μ g
In Type I diabetes	< 10 μ g
In Type II (obese with insulin resistance)	> 60 μ g
In type II with some insulin deficiency	< 30 μ g

Noninvasive Glucose Monitoring

1. The Gluco Watch Biographer: It automatically extracts glucose through the skin by reverse iontophoresis and measures glucose by electrochemical biosensor.
2. Infrared technology
3. Implantable sensor

Invasive Frequent Glucose Monitoring

The glucose oxidase sensor, which is located inside a small needle is placed in the subcutaneous tissue and is discarded after single use on removal. It can monitor glucose every 5 minutes up to 72 hours.



Treatment

Goal of therapy is to maintain euglycemia during most part of the day by aggressive insulin therapy. This is done to rest the damaged islet cells and to induce remission.

1. Insulin Therapy

Goals of Insulin Therapy

1. Elimination of primary glycosuric symptoms
2. Prevention of DKA and hyperosmolar coma
3. Restoration of lost lean body mass
4. Improvement in physical performance
5. Improvement in sense of well being
6. Reduction of frequent infections

Actions of Insulin

	Anabolic effects (↑)		Anticatabolic effects (↓)
Carbohydrate metabolism	Increases glucose transport (muscle, adipose tissue) Glucose phosphorylation Glycogenesis Glycolysis Pyruvate dehydrogenase activity Pentose phosphate shunt		Decreases gluconeogenesis Glycogenolysis
Lipid metabolism	Triglyceride synthesis Fatty acid synthesis (liver) Lipoprotein lipase (adipose tissue) activity		Lipolysis Lipoprotein lipase (muscle) Ketogenesis Fatty acid oxidation (liver)
Protein metabolism	Amino acid transport Protein synthesis		Protein degradation
Electrolytes	Cellular potassium uptake		
<i>Types of insulin</i>	<i>A chain</i>	<i>B chain</i>	
	<i>8th amino acid</i>	<i>10th amino acid</i>	<i>30th amino acid</i>
Human insulin	Threonine	Isoleucine	Threonine
Pork insulin	Threonine	Isoleucine	Alanine
Beef insulin	Alanine	Valine	Alanine

7. Decrease in foetal malformation, maternal and foetal morbidity
8. Delay, arrest or prevention of microvascular and macrovascular complications of diabetes.

Actions of Insulin (Fig. 9.32)

1. Short acting (regular/soluble)
2. Intermediate acting (NPH-isophane or lenteinsulin zinc)

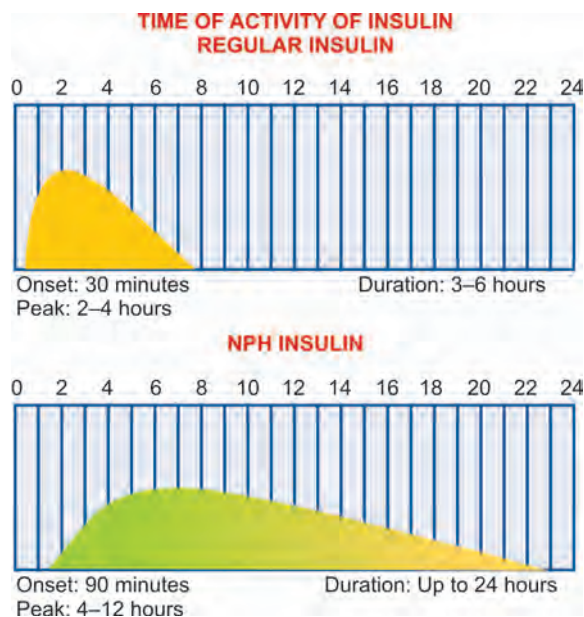

Fig. 9.32: Time of activity of insulin

3. Long acting (ultralente)-extended insulin zinc suspension.

Human Insulins

Human insulin is preferred at the time of diagnosis to prevent allergic complications. Since purity of insulin seems to be related to lipoatrophy at injection sites, human insulins are recommended.

These have more rapid onset of action than animal preparations and hence NPH may have to be administered late at bed time, instead of before supper to avoid early morning hyperglycaemia.

Insulin Analogues (Figs 9.33 and 9.34)

Lispro Insulin (Pro-Lys to Lyspro)

1. First human insulin analog-short acting
2. Recombinant DNA technology using non-pathogenic *E. coli*
3. B-28 proline replaced with lysine
4. B-29 lysine replaced with proline (i.e. pro-lis sequence is changed to lispro)
5. Does not aggregate or form hexamers
6. Quick onset, short duration
7. Hypos due to lispro are short lasting
8. Lispro is approved for post-prandial hyperglycaemia.

Insulin Aspart

1. Human insulin analog that is short acting.
2. B₂₈ proline is substituted with aspartic acid.

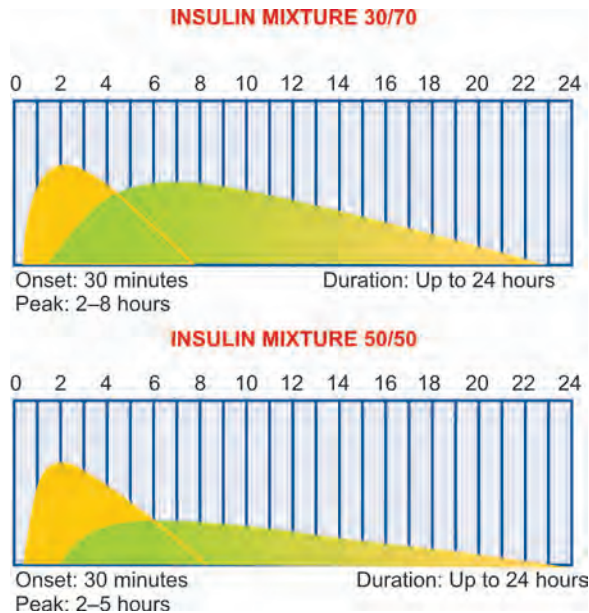

Fig. 9.33: Insulin

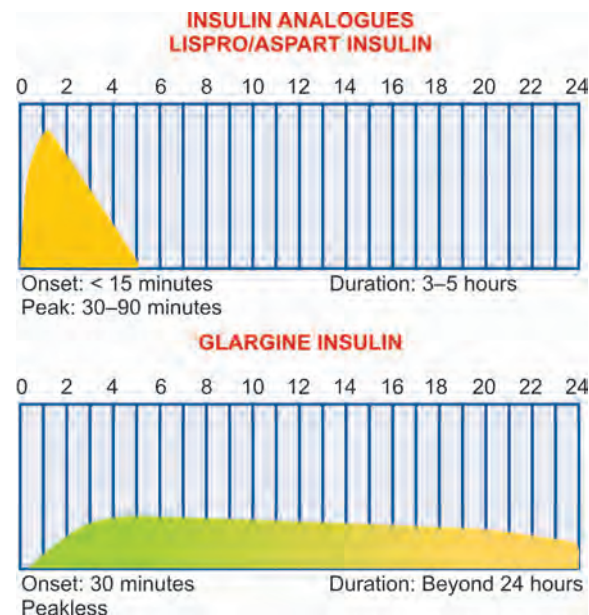

Fig. 9.34: Insulin

3. Saccharomyces cerevisiae is used.
4. No hexamer formation.
5. Pump compatible.

Insulin Glulisine

1. It is a short acting human insulin analog.
2. Substitution of amino acid lysine with asparagine at position 3 of the human insulin beta chain.

3. Substitution of amino acid lysine at position 29 with glutamine.

Short Acting Insulins Action Profile

	Lispro	Aspart	Regular
Onset (mts)	<15	<15	30-60
Peak	30-90	40-50	2-3 hrs
Duration (hrs)	3-5	4-6	3-6

Insulin Glargine

Glargine is a "peakless" bioengineered human insulin analog. After a lag time of 4-6 hours, the flat peakless effect lasts for a period of 24 hours. It is given once a day as subcutaneous injection at bed time along with premeal regular insulin or insulin lispro.

In some cases of type 1 DM, two injections are required for 24-hour coverage.

1. Human insulin analogue-long acting
2. Produced by rec.DNA tech
3. A-21 asparagine is replaced with glycine
4. At the end of the B-chain 2 arginine are added
5. Once a day glargine insulin at bed time is more effective than single or multiple doses of NPH
6. Can be used in lower dosage
7. Dawn phenomenon can be avoided
8. Hypoglycaemia does occur
9. No other significant side effects.

Disadvantage:

Higher incidence of pain at injection site.

Insulin Detemir

It is a long acting basal human insulin analogue. The amino acid threonine at the B30 position on the human insulin chain is lacking, and a 14-carbon fatty acid (tetradecanoic acid or myristic acid) is attached to lysine at B29.

1. It is neutral in pH and least painful at the site of injection
2. Albumin binding character allows the analogue to remain liquid and soluble following injection
3. Prolonged mode of action is due to attachment of fatty acid
4. Neither renal nor hepatic impairment exert influence on the pharmacokinetic profile
5. Less incidence of hypoglycaemia
6. No weight gain
7. It is effective when administered once or twice daily as part of basal bolus regimen along with either oral hypoglycaemic drugs or pre-meal short acting insulin regimen.

Blood glucose reading:	Hyperglycaemia before Breakfast	Hyperglycaemia before Lunch	Hyperglycaemia before Evening Meal	Hyperglycaemia at Bedtime
Add to the existing regimen	Previous day evening cloudy insulin	Same day morning clear insulin	Same day morning cloudy insulin	Same day evening clear insulin

Inhaled Insulin

It should be given 10 minutes before meals. It is available in 1-mg and 3-mg blister packs (1-mg is equivalent to 2.5 to 3 units of insulin). Patients should use one or two inhalations for any given dose. The onset of action is faster than that of regular insulin. The duration of action is between that of insulin lispro and regular insulin.

Hypoglycaemia, cough and bitter taste were reported. This insulin is not recommended for smokers and patients with pulmonary disorders (altered insulin absorption).

Dosage Schedule

- Aggressive insulin therapy using four shots of short-acting or two shots of intermediate-acting insulin is started in order to rest the damaged islet cells.
- Regular insulin should be added to NPH or lente insulin in patients with postprandial hyperglycaemia after breakfast and after supper.
- Insulin should be given 30 minutes before meal to allow adequate absorption.
- Insulin is given in a dose of 1 unit/kg/day. 50% should be given in the morning and 50% in the evening. Insulin should be given in the abdomen, buttock or hip areas where the muscles are less active to prevent rapid absorption.

“Honey-Moon” Phase

It occurs early in the course of type 1 DM.

This is due to partial recovery of β cell function as measured by c-peptide. It usually occurs 1-3 months after diagnosis and lasts for a few months during which time, insulin requirement falls drastically to as low as 0.3 units/kg/day. Insulin administration should not be discontinued (to prevent the development of insulin allergy if discontinued in between).

Eventually, insulin requirement in most youngsters becomes 0.6-0.8 units/kg/day. 2/3rd of the total dose is given as a mixture of regular + NPH or lente, half an hour before breakfast (1 unit regular: 3-4 units long acting insulin) and 1/3rd of the total dose is given as a mixture of regular + NPH or lente, 1/2 an hour before supper (1 unit regular: 1-2 units long acting insulin).

During pubertal growth spurt insulin requirement increases to 1-1.5 units/kg/day.

Insulin Regimens

1. Single Dose Regimen

Treatment with insulin is usually initiated with a single daily injection of intermediate acting insulin given before breakfast.

Starting dose of insulin is 0.2 units/kg/day up to 0.5-1 unit/kg/day. Increment should be made by 5 units every 3 to 4 days.

If control is not achieved, second injection is given before supper. Twice daily injections are commonly used because it is simple and convenient.

2. Multiple Daily Injections

Type 1 patients may require this kind of therapy with plain insulin 3 times daily before breakfast, lunch and dinner. If hyperglycaemia is not controlled, intermediate acting insulin is given either at bedtime or in the morning or at both times.

3. Bedtime Insulin (Intermediate Acting)

To decrease the excess hepatic overnight glucose production and to normalise fasting plasma glucose levels, bedtime insulin may be needed.

4. Mixed Insulin Therapy

Rapid acting insulins (regular, lispro, aspart) can be mixed with intermediate acting (NPH and Lente) or long acting ultralente insulins in the same syringe and care must be taken to take the rapid acting insulin first in order to avoid cross contamination. The mixed insulin should be given immediately. Commercial premixed insulin preparations are safe and convenient for use, but the dose adjustment of individual components is not possible.

Insulin glargine and protamine zinc insulin should not be mixed with other forms of insulin.

Insulin Delivery Systems

Insulin can be administered as an injection or via other insulin delivery devices.

Devices for Insulin Delivery

1. *Insulin syringes*: These are available in various sizes (40U, 80U). These can be used easily and there is enhan-



ced accuracy. Disposable syringes are preferable to glass syringes.

2. *Insulin pens*: An insulin pen holds a prefilled cartridge of the desired type of insulin and has a disposable needle that can be changed for each injection.

3. *External insulin pump therapy*: Portable insulin infusion pump or continuous subcutaneous insulin infusion (CSII) is an alternative method of injecting insulin subcutaneously. This can be in the form of

- a. Multiple boluses or
- b. Multiple basal rates (Insulin requirement can be preprogrammed and the delivery is according to that).

CSII involves a small portable pump with an infusion set ending in a needle or cannula inserted subcutaneously and changed every 24-72 hours.

CSII pumps can deliver as low as a tenth of a unit of insulin per bolus.

Advantages:

- Ease of taking multiple boluses if desired
- Ability to programme the basal rate of insulin delivery is especially useful in dawn phenomenon
- Improved control over multiple dose insulin (MDI)
- Decreased risk of development of severe hypoglycaemia
- Hypoglycaemic episodes can be easily treated.

Disadvantages:

- Infection at infusion sites
- High incidence of ketoacidosis
- High cost
- Risk of mechanical malfunction.

4. *Implanted insulin pump therapy*: Controlled pumps can be implanted in the peritoneal cavity. Insulin released into the peritoneal cavity is mostly absorbed and delivered into the splanchnic system.

This minimizes systemic hyperinsulinaemia and decreases incidences of hypoglycaemia.

Factors Influencing Insulin Absorption

- Human insulin is absorbed faster than animal species of insulin.
- Physical conditions at the injection site (increase in temperature, blood flow, degree of exercise, massage of injection site) will increase rate of absorption.
- The depth of injection is related to absorption. Deeper the injection, faster is the rate of absorption.
- Relative rate of absorption is different at different sites e.g., abdomen > arm > thigh > buttock.

Diabetes and Exercise

Exercise presents various problems for individuals with diabetes as they lack the normal glucoregulatory mechanisms. Those with Type 1 DM are prone to either hyper- or hypoglycaemia during exercise depending on the pre-exercise plasma glucose, circulating insulin level and exercise induced catecholamines. In the presence of low insulin levels, there is a high probability for hyperglycaemia due to exercise induced catecholamine release. In the presence of excessive circulating insulins, hypoglycaemia results. This can be avoided by taking the meal one to three hours before exercise and supplemental carbohydrate feeding every 30 mts. Other measures include, decreasing the insulin dose before exercise and injecting insulin into a non-exercising area.

Exercise-induced hypoglycaemia is less common in those with type 2 DM, but can occur in patients taking insulin or sulfonylureas.



Complications of Insulin Therapy

1. Hypoglycaemia

This is due to

- a. Inaccurate self-monitoring
- b. Variability in timing and composition of meals and snacks.
- c. Variability in timing and amount of exercise.
- d. Variability in insulin absorption.
- e. Acute illness—if nausea and vomiting are present.
- f. Critical illness—reducing insulin requirements (renal, liver, adrenal, pituitary failure)
- g. Weight loss
- h. Alcohol intake
- i. Hypoglycaemic unawareness due to drugs, tight glycaemic control, autonomic neuropathy, recurrent hypoglycaemic episodes
- j. Defective counter regulatory hormone response to hypoglycaemia
- k. Pregnancy
- l. Gastroparesis.

2. Insulin Resistance

It is arbitrarily defined as a situation in which the requirement of insulin exceeds 200 units per day to prevent hyperglycaemia and ketosis.

Relative insulin resistance is present in most of the patients when carefully looked for, using the glucose clamp technique.

In Type 1 DM it is due to near complete insulin deficiency and in Type 2 DM, the major problem is due to obesity.

Insulin receptor has two α and two β subunits. Insulin gets attached to a subunits and this activates β subunits (tyrosine kinase). Tyrosine kinase auto-phosphorylates the insulin receptor and initiates subsequent intracellular phosphorylations that mediate multiple actions of insulin.

Glucose transporters facilitate glucose entry into the cell (facilitated diffusion). Binding of insulin to the receptor initiates a rapid mobilisation of intracellular stores of the transporter to the plasma membrane while simultaneously activating those units already in place. In poorly controlled diabetes, the number of stored transporters appears to be deficient.

Insulin resistance may be at

1. Prereceptor level
 2. Receptor level
 3. Post-receptor level.
- Prereceptor level resistance is due to the presence of abnormal insulin or insulin antibodies.
 - Receptor level resistance is due to decrease in number of receptors or decreased binding of insulin.
 - Post-receptor level resistance is due to abnormal signal transduction resulting in failure to activate the tyrosine kinase receptor.

In diabetics with insulin requirements > 200 units/day, the resistance is mainly at prereceptor level due to insulin antibodies of IgG type (present in all patients within 2 months of initiation of insulin therapy).

Onset may be abrupt or gradual leading to uncontrollable hyperglycaemia. 20–30% of patients have concomitant insulin allergy.

Insulin Resistant States

- i. Prereceptor resistance (mutated insulins, anti-insulin antibodies)
- ii. Receptor and post-receptor resistance
 - a. Obesity
 - b. Type A syndrome (absent or dysfunctional receptor)
 - c. Type B syndrome (antibody to insulin receptor)
 - d. Lipodystrophic states (generalised or partial)
 - e. Leprechaunism (elfin facies, hirsutism, thick skin, absence of subcutaneous fat)
 - f. Ataxia telangiectasia (cerebellar ataxia, telangiectasia, immune system abnormality)
 - g. Rabson-Menderhall syndrome (dental dysplasia, dystrophic nails, premature puberty, acanthosis nigricans)

- h. Werner syndrome (autosomal recessive; growth retardation, alopecia, premature graying of hair, cataract, leg ulcer, atrophy of muscle, fat and bone, soft tissue calcification, sarcomas, meningiomas)
- i. Alstrom syndrome (autosomal recessive; childhood blindness (retinal degeneration), nerve deafness, vasopressin resistant diabetes insipidus, hypogonadism in males and end organ resistance to multiple hormones, baldness, hyperuricaemia, hypertriglyceridaemia and aminoaciduria).
- j. Pineal hyperplasia syndrome (early dentition with malformed teeth, dry skin, thick nails, hirsutism, sexual precocity with enlargement of external genitalia).

Other conditions of insulin resistance are already mentioned.



Treatment

Prednisone should be given in a dose of 80–100 mg/day. Response occurs in 2–3 days usually. If there is no response up to 3–4 weeks, steroids should be withdrawn.

If there is response, and if insulin requirements begin to fall, prednisone can be gradually decreased to 10–20 mg even in 3–7 days until a maintenance level of 5–10 mg is reached. It can be continued for many months.

When resistance is extreme, up to 500 units of regular insulin may be required; Addition of a protease inhibitor (aprotinin) to the insulin mixture can be useful.

3. Insulin Lipodystrophy and Lipohypertrophy

4. Insulin Allergy

Local allergy at injection site: Redness, pruritus, swelling and heat occurs. It usually occurs within the first few weeks of therapy and is self-limiting. This is IgG mediated.

Systemic allergy: Urticaria, angioneurotic oedema and anaphylaxis can occur but rare, this is related to prior intermittent use of insulin. This reaction is IgE mediated.

5. Insulin Oedema

Patients who have been having poor glycaemic control in the past, may develop peripheral oedema when their glucose is rapidly brought down. CCF is also common. It is a self-limiting condition clearing in about one week unless the patient has a renal or cardiac problem.

Home monitoring of glycaemic status can be done by

- i. Double voided urine testing for sugar and ketones. Patient is asked to empty the bladder 15 minutes

before the test. He is advised to consume water so that a fresh sample of urine is obtained.

- ii. a. Home blood glucose is monitored by using various reagent strips. Skin is punctured using automatic lancet injectors.
- b. Reflectance meters (Glucometer III, Accucheck III) are widely used with accuracy.
- c. Blood sugar monitoring from ear lobe or finger tip should be done for at least 3 consecutive days in a month, for a minimum of 4 times (prebreakfast, prelunch, presupper and at bedtime) and maximum of 8 times (postprandial samples in addition) during each 24 hour period. In patients with early morning hyperglycaemia, an additional sample at 3 am should be taken. During sick days, monitoring should be done every 1–2 hours to identify subtle hypoglycaemia and/its after effects.

Goal of therapy is to maintain euglycaemic level at all times.

Any preprandial level should be maintained at 70–90 mg/dl and postprandial level lower than 160–180 mg/dl. In very young children, and in insulin sensitive individuals, insulin can be diluted using diluent given by the manufacturer.

Glycated Haemoglobin

Control	Hb A ₁ (%)	Hb A _{1c} (%)
Good	8–10	6–8
Fair	10–12	8–10
Poor	12–14	10–12
Very poor	> 14	> 12

Hb A₁ = Hb A₁ (a, b, c)

Hb A_{1c} is preferred since the glycosylation is with glucose and not with other sugars.

Hb A_{1c} of 6% corresponds approximately to a mean plasma glucose level of 120 mg%. For every 1% rise in HbA_{1c}, mean glucose rise by 30 mg%.

This test is an indicator of blood sugar control during the previous 2–3 months period; Blood is used after saline washing to detect the relative percentage of glycosylated haemoglobin present.

- a. Glucose attaches to Hb in an irreversible fashion throughout its lifespan. At any given point of time, a sample represents a collection of newborn, middle age and senescent RBCs. Hence glycohaemoglobin level obtained represents a glucose value that is reflective of the glucose environment confronting red cells over the previous 3 months period.
- b. Methods used to detect glycated haemoglobin are high pressure liquid chromatography or gel electrophoresis; the subfraction A_{1c} is separated out. Values

less than 10% of glycosylated haemoglobin are acceptable. This test tells about the previous glycaemic control also, so that insulin dose can be adjusted.

Haemolytic anaemia, haemoglobinopathies and uraemia may interfere with estimation of glycated haemoglobin.

Glycosylated albumin, or total proteins (fructosamine) can also be estimated to find out the previous status of glycaemic control. Since the half-life of serum protein is short (20 to 25 days), this estimation gives an idea about the glycaemic status in the previous 2 to 3 weeks only.

Normal fructosamine level—0.9 to 1.5 ng/dl; > 1.5 ng/dl—abnormal.

Uncontrolled Diabetes Mellitus and Recurrent DKA

Noncompliance is a major cause of recurrent ketoacidosis in children.

Hypoglycaemia

Most episodes are predictable and preventable. But children are usually unaware of hypoglycaemic symptoms. The combination of alcoholic beverages with insulin produces very severe hypoglycaemia. Abnormal counter regulatory response in diabetic patients may account for prolonged hypoglycaemia.

Fasting Hyperglycaemia

Somogyi Phenomenon (Rebound effect): This is hypoglycaemia induced hyperglycaemia due to increased secretion of counter regulatory hormones.

If the insulin dose is increased beyond the amount required for any given portion of the day, there is counter regulatory hormone response, resulting in hyperglycaemia. Reduction of insulin is advised in such situations.

Dawn Phenomenon: Many patients with IDDM demonstrate early morning (4–8 AM) hyperglycaemia that is aggravated again by intake of food during breakfast (but not due to it). It may either be due to increased hepatic glucose production or decreased peripheral utilisation or both. In this condition, an excess of insulin is needed to control hyperglycaemia.

Early morning blood sampling at 3 am is necessary to differentiate both the conditions.

Type 2 Diabetes Mellitus

It is the most common type of diabetes accounting for 85–90% of the cases.

Risk Factors

1. Family history of DM
2. Obesity
3. Physical inactivity
4. Previously identified IGT
5. History of gestational DM
6. Delivery of large baby (> 4 kg)
7. Hypertension
8. HDL level < 35 mg/dl
9. TGL level > 250 mg/dl
10. Polycystic ovary syndrome
11. Acanthosis nigricans
12. History of vascular disease.

Pathophysiology

The characteristic pathophysiologic abnormalities of Type 2 DM are:

1. Impaired insulin secretion.
2. Peripheral insulin resistance.
3. Excessive hepatic glucose production.

There are 3 phases of development.

I phase (euglycaemia with increased insulin levels): Plasma glucose remains normal despite demonstrable insulin resistance because insulin levels are elevated.

II phase (post-prandial hyperglycaemia with increased insulin levels): Insulin resistance tends to worsen so that despite elevated insulin concentrations, glucose intolerance becomes manifest by post-prandial hyperglycaemia.

III phase (overt diabetes with declining insulin levels): Insulin resistance does not change but insulin secretion declines resulting in fasting hyperglycaemia and overt diabetes.

Resistance to insulin in Type 2 diabetes is at post-receptor level. The substance responsible for this is termed amylin.



Clinical Features

Patients are usually obese; symptoms begin gradually (polyuria, polydipsia, polyphagia); patient may present with unhealed wounds, fungal infections, pruritus vulva or balanitis; patient can have frequent changes in refractory error and may have early development of cataract; patient may be asymptomatic also.

Rule out diabetes in tuberculous patients above 40 years and also in mothers who have babies born with a weight of more than 4 kg (macrosomia).

General Characteristics Type 1 and 2 DM

Features	Type 1 DM	Type 2 D
1. Genetic locus	Chromosome 6	Multifactorial
2. Age of onset	<30 yrs	>30 yrs
3. Body weight	Lean	80% obese, 20% lean
4. P. Insulin	Low or absent	Normal or high
5. P. Glucose	High, suppressible	High, resistant
6. Acute complications	DKA	NKHS
7. Insulin therapy	Essential	Early may not require Late may require
8. Sulphonylurea	Unresponsive	Responsive
9. Autoantibodies	Present	Absent
10. Early death without treatment	Yes	No
11. Associated disorder	Autoimmune diseases	Insulin resistance Hypertension Hyperlipidaemia Polycystic ovary

Diagnosis

A. According to National Diabetes Data Group (NDDG), Type 2 DM is Diagnosed when a Patient

- i. Is not ketosis prone under basal conditions does not require exogenous insulin for short-term survival
- ii. Random blood sugar > 200 mg/dl on two occasions
- iii. Has a fasting plasma glucose > 126 mg/dl or a sustained elevation of plasma glucose concentration > 200 mg/dl after an oral glucose load of 75 gm at two hours.

B. Patients with Impaired GTT

10–50% of patients with impaired glucose tolerance develop Type 2 DM over a period of 10 years.

Diagnostic criteria for impaired GTT are:

Impaired glucose tolerance (IG) is defined by a 2-hour oral glucose tolerance test where the plasma glucose is > 140 mg/dl but < 200 mg/dl

Impaired fasting glucose is defined by a fasting plasma glucose of 110 mg/dl or greater but < 126 mg/dl/.

IFT and IGT are associated with insulin resistance and they are prone for micro/macrovascular complications and might end up with overt DM type 2.

Patients with impaired glucose tolerance are at an increased risk for atherosclerosis.

Patients with impaired glucose tolerance need further evaluation at a later date since they are potential diabetics.



It is treated with diet therapy, exercise, biguanides and sulphonylureas like glypizide and gliclazide. IGT is an important marker of skin disorders, neuropathy and hyperglycaemia in pregnancy.

C. Intravenous Glucose Tolerance Test

Preparation: Patient is given 3 days of unrestricted diet containing at least 150 gm of carbohydrate and has normal physical activity. Physical exertion should be avoided for 1 day prior to the test. Test should not be done in patients with intercurrent illness.

Fasting is advised for at least 10 hours to a maximum period of 16 hours. Water alone is permitted. Smoking should be avoided.

Time of start of test (glucose infusion): 7.30–10 A.M.

Glucose dose: 0.5 g/kg up to 35 g 25% glucose diluted in normal saline and infused manually or by a pump in 3 minutes \pm 15 seconds.

Two baseline samples and samples at 1, 3, 5, and 10 minutes after the test are taken. It is done for patients who cannot take oral glucose.

Glucose is present in urine and there is confusion with the diagnosis of diabetes in the following conditions.

Renal Glycosuria

The most common cause of glycosuria is a low renal threshold for glucose, which commonly occurs temporarily in pregnancy and is a much more frequent cause of glycosuria than diabetes in young people. Renal glycosuria is a benign condition and is not accompanied by the classical symptoms of diabetes.

Alimentary (Lag Storage) Glycosuria

In some individuals, an unusually rapid and transitory rise of blood glucose occurs following a meal. The concentration of glucose exceeds the normal renal threshold and it is present in the urine. This response following a meal or a dose of glucose is known as a 'lag storage' or alimentary glycosuria. It may occur in normal people or after gastric surgery (due to rapid gastric emptying leading to an increased rate of absorption into the blood stream), and also in patients with hyperthyroidism or hepatic disease. This type of blood glucose curve is usually benign and is unrelated to diabetes. The peak blood glucose concentration is abnormally high and the value two hours after oral glucose is normal.

Potential Diabetics

These are persons with a normal OGTT, who have an increased risk of developing diabetes for genetic reasons. E.g. individual who has a first degree relative with diabetes.

Latent Diabetics

These are persons who have a normal OGTT but who are known to have given an abnormal result under conditions imposing a burden on pancreatic β cells, e.g. Pregnancy, infection, myocardial infarction, steroid therapy.



Treatment

1. Diet Planning

Diet control is an endogenous insulin preserver.

- a. Primary therapeutic goal is weight loss in obese individuals; Reduction in weight eliminates the need for oral hypoglycaemic drugs or insulin, especially if normal body weight is achieved. Consistency in composition and timing of meals is important particularly for patients using fixed insulin regimens or oral hypoglycaemic drugs.
- b. Hypocaloric diets:
 - Caloric calculations is done for ideal body weight.
 - Total calories should be kept ideally between 1000 and 1200 kcal/day;
 - For obese individuals, 20 kcal/kg ideal body weight
 - For normal adults (sedentary), 30 kcal/kg ideal body weight
 - For normal adults (manual worker) and growing children, 40 kcal/kg ideal body weight.

Carbohydrates: Carbohydrate should constitute 50–60% of total calories. Concentrated sugars are avoided except in the treatment of hypoglycaemia. Nibbling of foodstuff rather than gorging is recommended to slow the rate of carbohydrate absorption.

Fibers: About 25 gm of fibers per 1000 kcal is advised. Complex high-fiber carbohydrates (bran, whole grain cereals, breaks, legumes, vegetables and whole fruit) are recommended. Soluble fibres like guar 15 gm/day should be consumed.

Proteins: The total protein content of the diabetic meal plan should be 25–30%.

Fats: Total fat content should be between 25 and 30% of total calories. Skimmed or low fat milk is advised; only 2–3 eggs per week are allowed. Margarine should be

taken instead of butter. Red and brown meat should be taken in reduced amounts. Fish and skimmed milk based cheeses can be taken.

Meal plan: Total calories have to be consumed as three major meals and three snacks in between major meals (breakfast 30%, midmorning snacks 10%, lunch 20%, evening snacks, 10% dinner 20% and bedtime snacks 10%).

General dietary considerations:

- Hunger, fasting or over feeding should be avoided
- Start with 1000 kcal/day for a 1 year old and increase by about 100 kcal/year thereafter up to adolescence. In adolescence, boys may need up to 3000 kcal/day for covering regular athletic activity when needed. Late adolescent males and young adult males require about 2200–2500 kcal/day.
- Girls need calorie restriction at about 10–12 years because of early puberty, so that meal plans are increased to about 1800–2000 kcal/day until this stage and then decreased to 1100–1700 kcal/day according to metabolic needs.
- Ice-cream can be liberalized because of its protein and fat content, especially when given in association with 30–90 minutes of continuous activity.
- “Cheat” days are allowed 3 to 4 times during a year counter balancing with insulin and activity.
- Avoid excessive sodium and alcohol. Alcohol inhibits hepatic gluconeogenesis, potentiates hypoglycaemic action of oral drugs. It may cause lactic acidosis. When used with sulfonylureas it causes disulfiram like reaction. The calorie content of alcohol is also high (empty calories)
- Judicious use of artificial sweeteners are recommended.

Artificial sweeteners like sorbitol and fructose are rich in energy and are not very useful. Their total intake should not exceed 50 g/day.

Non-nutritive sweeteners like saccharin, aspartame, sucramate and acesulphane K are widely used; they provide less energy without loss of palatability.

- In patients with hyperlipidaemia, lipid lowering agents can be given only on failure of diet therapy (step 1 and step 2). (refer chapter on hyperlipidemia).

Type of lipid	Minimal goal (mg/dl)	Ideal goal (mg/dl)
Total cholesterol	< 200	170
LDL	< 130	100
Non-HDL cholesterol	< 160	130

2. Exercise

Isotonic exercises like brisk walking, swimming or cycling are recommended.

- Exercise potentiates beneficial effects of diet and other therapy. Aerobic exercises for 30–45 minutes/day, 5 times per week should be advocated. The rest period between exercise should not exceed 48 hours. Exercise is less effective in poorly controlled diabetics. In these individuals, exercise potentiates existing hyperglycaemia.
- Vigorous exercise in those patients who have neither decreased their insulin nor increased their carbohydrate intake, might result in hypoglycemia. Hence, insulin should be reduced by 20–25% on the day of strenuous exercise. If he has already injected the usual dose, 20–30 gm of carbohydrate should be ingested prior to exercise, unless there is 2+ glycosuria or significant hyperglycaemia.
- Feet and joints should be monitored after exercise especially if there is evidence of peripheral neuropathy.
- If autonomic neuropathy is present, heart rate will not increase during exercise; there is also increased risk of cardiac arrhythmias and postexercise orthostatic hypotension.
- Exercise regimen should start with warm up stretching, for 10 minutes, aerobic exercise for 30 to 45 minutes, and cool down stretching for 5 to 10 minutes.
- When there is a persistent increase in blood sugar > 250 mg/dl, despite diet control and mild exercise regimens, vigorous exercise may be best avoided till blood sugar begins to fall.
- Screen for CVS disease (ECG, stress test) before starting exercise regimen.
- Avoid isometric exercises (bull worker, weight lifting).

Exercise and energy expenditure per hour:

- Mild exercise
 - One hour standing—120 kcal/hr
 - Lying down—70 kcal/hr
 - Sitting—80 kcal/hr
 - Walking (2.5 mph)—180 kcal/hr.
- Moderate exercise
 - Swimming (0.25 mph)—250 kcal/hr
 - Fast walk (3.75 mph)—250 kcal/hr.
- Vigorous exercise
 - Tennis—350 kcal/hr
 - Cycling (10 mph)—600 kcal/hr
 - Running (10 mph)—800 kcal/hr.

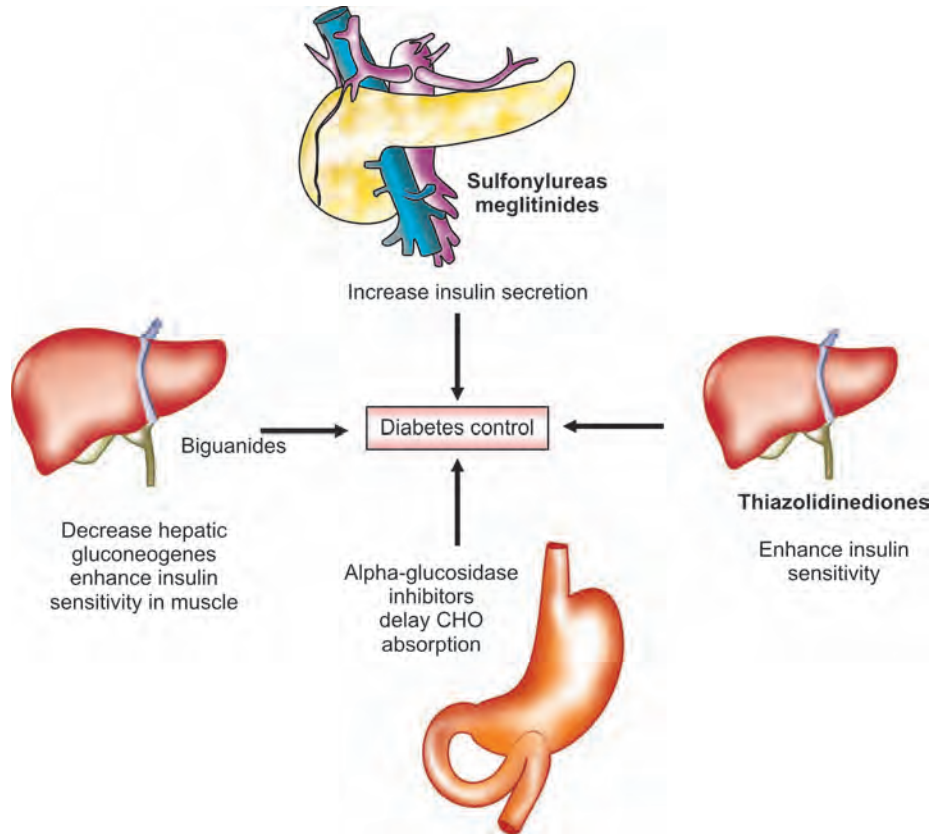

Fig. 9.35: OHA—mechanism of action

3. Drug Therapy

In obese individuals, drug therapy is advocated when intensive therapy with diet modification and exercise fails. Drugs are given when fasting plasma glucose is > 140 mg/dl and post prandial level is > 250 mg/dl in spite of regular exercise and diet control or when there are symptoms of hyperglycaemia, persistent ketosis, hyperosmolality or hyperlipidaemia.

A. Oral Antidiabetic Agents (Fig. 9.35)

I. Insulin secretagogues:

(i) Sulfonylureas

Sulfonylureas act by stimulating release of insulin from the pancreatic β cell. It upregulates the insulin receptors and magnifies the effect of available insulin. The hypoglycaemic effect is due to the reduction in hepatic release of glucose and diminished insulin resistance. Sulfonylureas reduce fasting blood glucose by approximately 70–80 mg/dl.

They are effective in lean diabetics and should not be prescribed in obese patients as first line of therapy; They are already hyperinsulinemic and treatment with sulfonylureas aggravate this thereby increasing weight. In obese, sulfonylureas are tried only when vigorous diet, biguanides and exercise program have failed.

Extrapancreatic actions of sulfonylureas

I. Liver

A. Direct effects

1. Increases fructose-2, 6-biphosphate
2. Increases glycolysis
3. Decreases gluconeogenesis
4. Decreases oxidation of long-chain fatty acids

B. Potentiate insulin action

1. Increases hepatic glycogen synthase and glycogen synthesis
2. Increases hepatic lipogenesis

C. Decreases hepatic extraction of insulin

II. Skeletal muscles

A. Direct effects

1. Increases glucose transport
 2. Increases fructose-2, 6-biphosphate
- B. *Potentialiation of insulin stimulation of carbohydrate transport*
- III. *Adipose tissue*
- A. *Direct effects*
1. Increases adenosine-3' 5'-monophosphate diesterase and inhibition of lipolysis
 2. Increases glycogen synthase
- B. *Potentialiation of insulin-mediated glucose transport and translocation of glucose transport molecules.*
- Chlorpropamide has a central action also and it is equivalent to ultralente insulin. Its hypothalamic action has made it useful in diabetes insipidus.
 - Gliclazide has a smooth action resembling physiological insulin secretion.

Treatment response

Primary failure: About 15% of patients show inadequate response to sulfonylureas during the first month of treatment with maximal dosage. This is primary sulfonylurea failure. If hyperglycaemia (fasting plasma glucose > 140 mg% and post-prandial glucose > 250 mg/dl) persists even after 1 month of drug therapy while the patient is on strict diet therapy and exercise, primary failure is diagnosed and insulin may have to be started.

Secondary failure: Some patients (5–10%) show initial satisfactory response followed by recurrence of hyperglycaemia. This is called secondary failure. The causes for secondary failure are:

1. Non-adherence to either diet or sulfonylurea therapy.
2. Disease progression.
3. Loss of efficiency of the drug.
4. Intercurrent illness
5. Physical or mental stress.

Side effects of sulfonylurea therapy

- a. Hypoglycaemia: This is prolonged and recurrent. Treatment and intense monitoring should be continued for at least a week.
- b. Several drugs may potentiate the action of sulfonylureas sulfonamides, coumarin, phenylbutazone, phenytoin etc.
- c. Sulfonylureas should not be used in patients with liver disease, renal disease, allergic reactions to sulfonylureas or during pregnancy.
- d. Chlorpropamide induces fluid retention by exerting ADH effect on distal tubules.
- e. Patients may experience flushing after alcohol intake.

Selection of sulfonylureas

1. Second generation drugs are advantageous.
2. For elderly, glipizide is preferred since there is less incidence of hypoglycaemia with this drug. Glyburide (Glibenclamide) is preferred when there is fasting hyperglycaemia.
3. In renal insufficiency, drugs having dual route of excretion (liver and biliary) like glyburide or drugs with inactive liver metabolites like glipizide should be used.
4. Drugs should be started in small dosage and should be increased gradually based on self-monitoring of blood glucose.

(ii) *Meglitinide*

These are a new class of insulin secretagogues which modulates β cell insulin release by regulating potassium channels. The first member of the group is Repaglanide – 0.25 to 4 mg before each meal. It has very fast onset of action with peak effect within 1hr of ingestion. Duration of action is 4-5 hrs. Because of the rapid onset and short duration it is indicated for postprandial glucose control.

Contraindication includes hepatic impairment. Since there is no sulphur in the structure, it can be used in patients with sulfonylurea allergy.

(iii) *Nateglinide*

It is a D phenylalanine derivative which acts directly on β cells to stimulate early insulin secretion.

Dose: 120 mg orally taken 10 mts before each meal

Leads to insulin secretion within 15 mts and return to baseline in 3-4 hrs. It is effective in control of postprandial hyperglycaemia.

II. Insulin sensitisers:

(i) *Biguanides*

The drugs under this group are phenformin and metformin. These are drugs of choice for obese type II diabetes. They have no effect on insulin secretion. They improve peripheral tissue sensitivity to insulin thereby enhancing peripheral utilisation of glucose. They suppress hepatic production of glucose by reducing gluconeogenesis. They do not cause weight gain and rather facilitate weight loss (due to anorexic effect). The drug also decreases triglycerides, especially when they are elevated. It also increases glucose transporters in insulin sensitive cells.

Biguanides can be given orally alone or with insulin. Primary failure is 5–20% and secondary failure is 5–10%, Starting dose of metformin is 500 mg/day with meals up to 3 gm/day in 2–3 doses.



They should be avoided in patients with renal or hepatic insufficiency, in alcoholics, in cardiopulmonary insufficiency and in other known risks for lactic acidosis. They should not be used in pregnancy. Absorption is decreased by guar gum. Cimetidine delays its renal clearance. Biguanide can be used along with sulfonylureas and the combination has an additive glucose lowering effect.

Metformin should be withheld for one day prior to contrast studies with iodinated dyes and it can be restarted 48 hours after the contrast study (If renal function is normal).

(ii) *Thiazolidinediones*

They improve insulin sensitivity in muscle, liver and adipose tissue. There is reduced hepatic glucose production also. It seems to reduce plasma triglyceride levels and increases HDL cholesterol levels. There is no hypoglycemia, as they do not affect pancreatic insulin secretion. Patients with little pancreatic insulin reserve do not respond adequately. Hence it is used in type 2 DM it also prevents the progression from IGT to type 2 DM. They can be combined with other oral hypoglycemic agents or insulin.

Pioglitazone 15-45 mg OD

Rosiglitazone 2-8 mg OD

Pharmacology of Sulfonylurea Drugs

Drug	Duration of action	Dosage	Protein binding	Hepatic metabolites	Route of excretion
I generation					
a. Tolbutamide	6-12	500-3000 mg in 2-3 doses	ionic	inactive	liver
b. Chlorpropamide	24-72	100-500 mg in a single dose	ionic	inactive; weakly active	kidney
c. Acetohexamide	12-18	250-1500 mg/day up to 750 mg BD		active	kidney
d. Tolazamide	16-24	100-1000 mg (up to 500 mg BD)		weakly active	kidney
II generation					
a. Glipizide	12-24	2.5 to 40 mg in 1-2 doses	non-ionic	inactive	liver/kidney
b. Glyburide/ glibenclamide	16-24	1.25-20 mg in 1-2 doses	non-ionic	inactive and moderately active	liver/kidney
c. Micronized glyburide	16-24	0.75-12 mg in 1-2 doses	non-ionic	inactive, moderately active	liver/kidney
d. Gliclazide	10-12	80-240 mg in 1-3 doses		probably inactive	liver (30%) kidney (70%)
e. Glimepiride	12-24	1-8 mg od	—	inactive	liver

Pharmacology of Other Oral Antidiabetic Agents

Drugs	Dosage/day	Interval	Duration of action	Adverse effects
<i>Meglitinide</i>	Rapid acting	Before	1-2 hours	Hypoglycemia and weight gain
Repaglinide	1-16 mg	Meals		
Nateglinide	180-360 mg	TID		
<i>Biguanide</i>	1-3 g	BID/TID	6-12 hours	Lactic acidosis and GI intolerance
<i>Alpha-glucosidase inhibitors *</i>				
Acarbose				GI intolerance and flatulence Minimal GI tolerance
Miglitol	75-300 mg	TID		
	75-300 mg	TID		
Voglibose	0.2 to 0.6 mg	TID		
(Poorly absorbed and renal excretion is negligible)				
<i>Thiazolidinediones</i>				
Rosiglitazone	2-8 mg	OD/BID	12-24 hours	Fluid retention, CHF, weight gain, hepatotoxicity
Pioglitazone	15-45 mg	OD	24 hours	

* Patients on alpha-glucosidase inhibitors when they develop hypoglycemia should be treated with glucose and not sucrose.

There should be frequent hepatic monitoring for idiosyncratic hepatic injury.

Contraindications

- Liver disease
- CCF—class III and IV

B. Alpha-Glucosidase Inhibitors: (Acarbose)

Delaying digestion and absorption of sucrose and complex carbohydrates may be advantageous. They require action of an intestinal brush border enzyme glucosidase for absorption. Inhibitors of this enzyme, when taken before a meal causes a slower rise and lower peak in blood glucose in both Type 1 DM and Type 2 DM;

30–50 mg/dl reduction of blood glucose and 0.5 to 1% reduction in HbA_{1c} has been reported with these drugs.

Acarbose is the most popular drug in this group and it is given in a dose of 50–100 mg TDS/day before meals.

Miglitol is the newer agent. It defers structurally from acarbose and is 6 times more potent in inhibiting sucrase.

Dosage: 25–100 mg

Adverse effects: Flatulence, diarrhoea, abdominal pain. The drugs are contraindicated in those with hepatic or renal disease and in patients with inflammatory bowel disease or gastroparesis.

C. Fatty Acid Oxidation Inhibitors (Acipimox)

In Type 2 DM, due to decreased insulin action on adipocytes, excess fatty acids are released. These may stimulate hepatic gluconeogenesis and lead to fasting hyperglycaemia. Acipimox, a nicotinic acid derivative (20 times more potent than nicotinic acid), decreases free fatty acid levels. It also lowers fasting hyperglycaemia and triglyceride levels.

D. Insulinotropins

- a. Glucagon like peptide 1 (GLP-1): This is under evaluation. GLP-1 is a fragment of proglucagon molecule. It seems to stimulate insulin release.
- b. Insulin like growth factor 1 (IGF-1) or somatomedin.

Incretins

Incretins are enteroendocrine derived gut peptides. They act on endocrine pancreas.

The predominant incretins are glucose-dependent insulinotropic polypeptide (GIP), which is secreted by the intestinal 'k' cells located in the duodenum and proximal small bowel and glucagons-like peptide-1 (GLP-1) which is secreted from the enteroendocrine 'L'

cells located in the ileum and colon. The GLP-1 stimulates both insulin secretion and production whereas sulfonylureas stimulate insulin secretion but not biosynthesis.

Excretins

The hormones such as secretin that stimulate the exocrine pancreas are called excretins.

GLP-1 Analog (Exendin 4)

The original peptide was identified from the oral secretion of the Gila monster. The newer analog improves insulin resistant state and decreases fasting, postprandial glucose level. It suppresses appetite and leads to weight loss. It also lowers triglyceride level.

Exenatide

It is a synthetic preparation of exendin 4 with prolonged duration of action. It is given parenterally in a dose of 5–10 µg twice daily. It can be given either with metformin or with sulfonylurea or with both. It helps in achieving good control of DM. Adverse effects are nausea and hypoglycaemia.

Amylin Analog (Pranlintide)

It delays absorption of carbohydrate from the GIT and suppresses postprandial glucagon levels and also induces weight loss.

Dipeptidyl Peptidase IV (DPP IV) Inhibitors

- An enzyme that degrades GLP-1
- DPP IV inhibitor inhibits the degradation of GLP-1 and thus enhances incretin effect
- It enhances glucose mediated insulin secretion
- It inhibits glucagons secretion

Sitagliptin

- An inhibitor of dipeptidyl peptidase IV
- It increases insulin secretion.
- It lowers glucagon secretion.
- It can be combined with metformin and thiazolidinediones
- It is contraindicated in ketoacidosis, pregnancy and breastfeeding.
- Dose—100 mg once daily PO.

Vildagliptin

- It is the second molecule of the DPP-IV inhibitor
- It can be combined with other OHAs and insulin
- It is weight neutral and has favourable effect on lipids
- Not recommended for paediatric patients



- Avoid in moderate renal failure, pregnancy and hepatic impairment
- Dose – 50 mg bid along with metformin, TZD or insulin or 50 mg qd along with sulphonylurea

Insulin

Indications in Type 2 DM

1. In primary or secondary sulphonylurea failure
2. Major trauma, surgery
3. Stress
4. Pregnancy
5. DKA
6. Myocardial infarction, CVA
7. Liver failure, renal failure and respiratory failure
8. Infections.

Principles of Insulin Therapy

- a. Start with a low dose; Gradually increase the dose to find out the optimum level. It can be given as a single prebreakfast injection of intermediate acting insulin or twice daily as prebreakfast and predinner doses (0.3–0.4U/kg/day)
- b. Blood glucose level should be monitored at home. When facilities are not available for blood sugar estimation, second voided urine samples are utilized.
- c. Insulin dosage and pattern of administration are adjusted until reasonable control of blood glucose is achieved. Then the frequency of blood glucose monitoring is decreased to 3–4 times a day, later once or twice weekly sugar estimation is sufficient.

Insulin is Maximally Tolerated in the Following Conditions

1. Pregnancy
2. Neuropathy
3. Skin lesions.

Diabetic Complications (Fig. 9.36)

Acute complications

1. Diabetic ketoacidosis
2. Hyperosmolar coma
3. Hypoglycaemia.

Chronic complications

- I. Microvascular
 - a. Eye disease
 - i. Retinopathy (proliferative/nonproliferative)
 - ii. Macular oedema
 - iii. Cataract
 - iv. Glaucoma
 - b. Neuropathy
 - i. Sensory and motor (mono and polyneuropathy)

ii. Autonomic

c. Nephropathy

II. Macrovascular

- a. CAD – Coronary artery disease
- b. PVD – Peripheral vascular disease
- c. CVD – Cerebrovascular diseases

III. Others

- a. Gastrointestinal
- b. Genitourinary
- c. Dermatologic
- d. Cardiomyopathy

Acute Complications of Diabetes

Diabetic Ketoacidosis (DKA)

DKA is characterised by a plasma glucose > 250 mg/dL, arterial pH < 7.30 or serum bicarbonate level < 15 mEq/L and moderate ketonemia with ketonuria.

This is the most frequent endocrine emergency; it has a mortality of 6–10%. All the abnormalities can be traced to an absolute or relative insulin lack, which develops over a period of several hours or days.

It is more common in type I diabetes. In newly diagnosed patients, there is failure of endogenous insulin secretion whereas in a known NIDDM patient, it is due to the insulin deficiency occurring as a result of either inadequate administration of exogenous insulin or a stressful condition. Stresses can be:

1. Infection (pneumonia, UTI, URI, meningitis, cholecystitis or pancreatitis)
2. Vascular disorder (MI, CVD)
3. Endocrine disorder (hyperthyroidism, Cushing's syndrome, acromegaly, pheochromocytoma)
4. Trauma
5. Pregnancy
6. Emotional stress (especially in adolescence).
7. Drugs—cocaine.

Pregnancy and alcohol ingestion are associated with “euglycemic DKA.”

In these situations, there is increase in production of counter-regulatory hormones namely, epinephrine, cortisol, glucagon and growth hormone and hence the dose of insulin has to be increased. In 25% of patients, there is no precipitating cause.

Pathophysiology of DKA

Role of Insulin

- a. Insulin deficiency leads to hyperglycaemia, osmotic diuresis resulting in dehydration and electrolyte depletion.

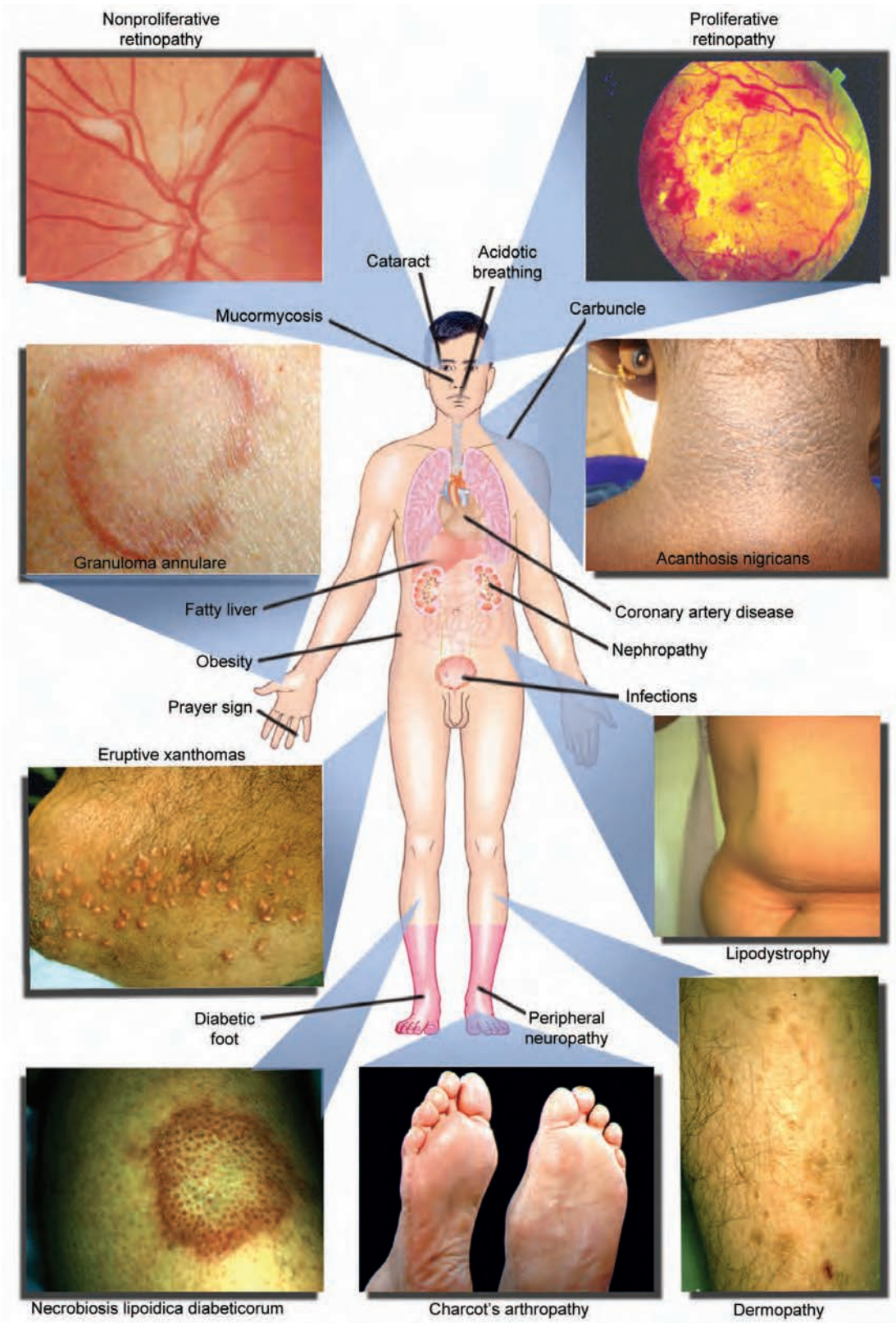

Fig. 9.36: Diabetes mellitus—complications



- b. Activation of glycogenolysis and gluconeogenesis and lipolysis by insulin lack, all resulting in new glucose production.
- c. There is also decreased peripheral utilisation of glucose (secondary to insulin lack and resistance) and volume depletion (secondary to osmotic diuresis) that decreases renal blood flow and therefore the amount of glucose filtered and excreted by the kidney.
- d. Free fatty acids are delivered to the liver, where ketone bodies are produced resulting in ketonemia, which is intensified by decreased peripheral utilisation. The resultant ketonuria further depletes the electrolytes.
- e. Acidosis occurs as a result of exhaustion of body bases in the process of buffering ketone bodies which are produced uncontrollably.
- g. Signs simulating surgical abdomen
- h. Hypotonia, stupor or coma
- i. Evidence of precipitating illness.



Investigations

1. Serum glucose is > 300 mg/dl (may vary from high normal to very high levels). Severe fluid and electrolyte loss and the presence of glucose contribute to increased osmolality in DKA (up to 340 mOsm/kg).
2. Ketones (acetone, acetoacetic acid (AAA), β hydroxy butyric acid)

Total ketone concentration is usually > 3 mM/L and can go up to 30 mM/L (Normal value—0.15 mM/L)

 - a. Acetone does not contribute to acidosis.
 - b. Ratio of β hydroxy butyrate to acetoacetate is 3 : 1 in mild DKA and 15 : 1 in severe DKA.
 - c. Ketostix, acetest, chemstrip (UKG) are the strips available to detect ketone bodies. Standard nitroprusside reagents in them react with acetoacetate and not with β hydroxy butyrate and the test can be false negative.
 - d. As DKA is getting corrected, β hydroxy butyrate is converted to acetoacetate and the test is high positive; This does not mean that there is worsening of DKA state.

False positivity for Ketones:
Drugs like captopril and penicillamine may cause false positive reaction.
3. Acidosis (due to accumulation of β hydroxy butyrate and acetoacetic acid)
 - a. Serum HCO_3^- level is < 15 mEq/L
 - b. Arterial pH is < 7.3

Some degree of lactic acidosis (due to hypoperfusion) and hyperchloremic acidosis (after IV therapy and during recovery phase) may also contribute to acidosis.
4. Electrolytes
 - a. Serum Na^+ is low, high or normal.

Presence of elevated serum glucose results in obligatory movement of water from intracellular to extracellular space causing apparent hyponatraemia despite dehydration and hyperosmolality. Hypertriglyceridaemia causes artefactual fall in serum Na^+ .
 - b. Serum K^+ level can be low, normal or high due to
 1. Egress of K^+ from cells secondary to acidosis.
 2. Intravascular contraction.

Actual K^+ deficiency cannot be estimated because of the above reasons. An initial low K^+ level, attests to severe depletion and should be managed aggressively.

Role of Counter Regulatory Hormones

Hypersecretion of epinephrine (EN), glucagon, cortisol and growth hormone (GH) results in DKA by

- a. Inhibiting insulin mediated glucose uptake by muscle-peripheral utilisation (EN, cortisol, GH)
- b. Activating glycogenolysis and gluconeogenesis (EN, glucagon, cortisol)
- c. Activating lipolysis (EN, GH)
- d. Inhibiting residual insulin secretion (EN, GH).



Clinical Features

Patients present with polydipsia, polyuria and weakness; anorexia, nausea, vomiting, and abdominal pain (especially in children) may be there due to ketonemia. Ileus and gastric dilatation may cause aspiration. A characteristic type of breathing called Kussmaul's breathing (deep, sighing) occurs as a respiratory compensation for metabolic acidosis especially when $\text{pH} < 7.2$.

Patients may have altered sensorium and 10% of them are comatose.

Clinical examination shows:

- a. Fruity or musty odour in breath
- b. Loss of skin turgor, dry tongue and decreased intraocular pressure resulting in sunken eyes
- c. Hypothermia (presence of fever is a strong evidence of infection)
- d. Tachycardia
- e. Hyperpnoea or Kussmaul's breathing depending on degree of acidosis.
- f. Hyporeflexia (decreased potassium)

- c. Serum PO_4 level may be normal and does not reflect actual body deficits as intracellular PO_4 shifts to extracellular space as a part of catabolic state.
5. Other tests
- BUN: 20–30 mg/dl due to volume depletion.
 - WBCs: 15,000–20,000/ μL in infections.
 - Serum amylase level is increased (may be due to increase in pancreatic or salivary amylase).
 - Increased transaminases (unknown significance)
 - In the presence of DKA, thyroid function tests are unreliable.



Management

- General
 - Monitor vital signs and neurologic status
 - Monitor a flow sheet including data on glucose (hourly), serum ketones, electrolytes, BUN, creatinine, calcium, phosphorous, arterial gases, urine glucose, and ketones.
 - Maintain intake and output chart.
 - A nasogastric tube, should be used in patients with shock, stupor or coma. Bladder should be catheterized
 - Continuous ECG monitoring to find out K^+ toxicity.
- Fluids
 - Replacement of intravascular volume is the mainstay of treatment of DKA. Isotonic saline (0.9%) or Ringer lactate solution should be used. The average fluid deficit in diabetic ketoacidosis is 6 litres, 3 litres from the extracellular compartment and 3 litres from intracellular compartment. In patients with normal cardiac function, initial fluid replacement is at a rate of 5-10 ml/kg/hr over the first 1-3 hrs.
 - In later stages when serum sodium is > 155 mEq/litre, $\frac{1}{2}$ normal saline may be substituted.
 - Rate of infusion is reduced to 150 to 250 ml/hour depending on clinical status and ongoing fluid losses.
 - Add 5% dextrose to IV solution when blood glucose ≤ 250 mg/dl.
- Potassium
 - Wait for serum K^+ level before adding KCl to the drip.
 - If clinical signs of hypokalaemia exist (ileus, hyporeflexia, abnormal ECG), infuse 20–40 mEq KCl/hour. Close ECG monitoring and frequent serum K^+ level are necessary. If K^+ level is < 2.5 mEq/l, 60 to 80 mEq/l/hour of KCl may be needed. Care should be taken in anuric patients.

Serum K^+	Dose of KCl (mmol/l of infused fluid)
> 5.5 mmol/l	No KCl
3.5–5.5 mmol/l	20
< 3.5 mmol/l	40

- Phosphate
 - Replacement of phosphate is controversial. Phosphate can be given as K^+ salt.
 - Monitor for hypocalcemia.
 - Do not give in presence of renal failure.
- Bicarbonate
 - Routine use of bicarbonate is controversial.
 - Indications are:
 - Life-threatening hyperkalaemia
 - Lactic acidosis complicating DKA
 - Severe acidosis ($\text{pH} < 6.9$) or shock or coma which is unresponsive to fluid therapy.
 - $\text{P. HCO}_3^- < 5$ mEq/litre
 - Acidosis induced cardiac and respiratory dysfunction.
 - If used, subtract amount of Na^+ given as sodium bicarbonate from Na^+ in replacement fluids.
 - 88 mEq (2 amp) in a litre of $\frac{1}{2}$ NS can be given over 1–2 hours and it should never be given as IV bolus.
- Insulin
 - Insulin given in a dose of 10–15 units as a bolus or 0.15 U/kg IV as an infusion is the treatment of choice in DKA.
 - Continuous infusion is given in a dose of 125 units regular insulin/250 ml NS at a rate of 0.1 unit/kg/hr (for a 60 kg individual, 6 units/hour i.e. 5 drops/minute).
 - Insulin infusion should be given until DKA is resolved, (usually 8–24 hours).
 - If no suitable veins are obtainable, IM injection can be given. 10–20 units regular insulin IM in deltoid as a loading dose and then 5–10 units/hr q1h until adequate glucose response is noted. Later insulin can be given every 2–4 hours.
 - When serum glucose lowers to 250 mg/dl, add 5% dextrose to IV solution.
 - A decrease in blood glucose of 50-75 mg/dl/hour is appropriate. Lesser decrease indicates insulin resistance or problem with insulin delivery. In case of insulin resistance the dose of hourly insulin can be increased by 50-100% to achieve proper glycemic control.

- Excessively rapid correction of hyperglycaemia (> 100 mg/dl/hr) has a risk of inducing osmotic encephalopathy (especially in children).
 - Reduce the dose of insulin to 1-2 units/hour when the serum bicarbonate rises to 15 mEq/L.
7. Magnesium 1-2 g IV over one hour is indicated in patients with ventricular arrhythmia.
 8. Treat infections with IV antimicrobials.

Distinguishing Features between DKA and Non-ketotic Hyperosmolar State

Features	DKA	NKHS
A. Clinical		
1. Type	Type 1 DM	Type 2 DM
2. Age	Younger	Older
3. Consciousness	Altered	Comatose
4. Seizures	Usually absent	May be present
5. Respiration	Kussmaul	Normal or shallow
6. GI symptoms	Usually present	Usually absent
7. Temperature	Normal or low	May be raised
B. Biochemistry		
1. B. Sugar	300-600 mg%	600-1200 mg%
2. Fluid deficit	3-5 litres	9-10 litres
3. Osmolality	300-320 milli osm/kg	330-380 milli osm/kg
4. Plasma ketones	4+	±
5. Anion gap	↑	Normal or slightly ↑
6. Arterial pH	6.8-7.3	>7.3
7. S. Na ⁺ (mEq/litre)	125 - 135	135 - 145
8. S. HCO ₃ ⁻	<15 mEq/litre	Normal or slightly ↓
9. S. creatinine	Slightly ↑	Moderately ↑
10. S. K ⁺	Normal or ↑	Normal
11. S. PO ₄	↓	Normal



Complications of DKA

- a. Metabolic abnormalities with treatment (severe acidosis, hypokalaemia, hypoglycaemia, and hypocalcaemia)
- b. Nonmetabolic complications
 1. Infection
 2. Shock (septic and hypovolaemic)
 3. Vascular thrombosis (especially of cerebral vessels)
 4. Noncardiogenic pulmonary edema
 5. Cerebral edema (It is rare and usually fatal, occurring mostly in children. The onset is 4-16 hours after initiation of therapy in spite of improvement in biochemical parameters. Headache, lethargy, mental stupor, and unconsciousness supervene in the previously conscious

patient. Patients show evidence of increased ICT, hyperpyrexia and diabetes insipidus. Use of mannitol (1-2 g/kg IV over 20 minutes) and possibly dexamethasone (0.25-0.50 mg/kg/day in divided doses every 4-6 hours) is recommended.

6. Lactic acidosis.
7. Arterial thrombosis manifesting as stroke, myocardial infarction, peripheral arterial thrombosis leading to ischaemic limb. Anticoagulants are useful.
8. Rebound ketoacidosis is due to premature cessation of insulin therapy.

Hyperosmolar Coma

When insulin deficiency is partial as in Type 2 DM patients, the anticatabolic effect of insulin may be relatively well-preserved while its anabolic action is more seriously defective. In these circumstances lipolysis is not markedly accelerated and the concentration of ketone bodies in the blood remains relatively normal despite severe hyperglycaemia. This state is called hyperosmolar coma.

Most of the patients have mild type II diabetes or no prior history of diabetes. Lack of ketosis in this syndrome has been explained by insulin levels high enough to prevent lipolysis and ketogenesis but not high enough to prevent hyperglycaemia.

Predisposing Factors

1. Infections (pneumonia, UTI, sepsis)
2. Drugs (steroids, potassium-wasting diuretics, phenytoin)
3. Other medical conditions (CVA, subdural haematoma, acute pancreatitis, and severe burns)
4. Use of concentrated glucose solutions as in dialysis.
5. Endocrine disorders (acromegaly, Cushing's disease, and thyrotoxicosis).



Clinical Features

Polyuria, polydipsia, weight loss, weakness, altered sensorium, evidence of underlying conditions and seizures are common.

Patient is severely dehydrated and may present with neurological deficits.



Investigations

1. Blood glucose level of > 600 mg/dl
2. Markedly elevated serum osmolality > 320 mOsm/litre.

Difference in Coma due to Hypoglycaemia and Ketoacidosis

	<i>Hypoglycaemic coma</i>	<i>Coma with ketosis</i>
History	No food intake; unaccustomed exercise	Too little or no insulin; or an infection or digestive disturbances
Onset	In good previous health; related to last insulin injection	Ill health for several days
Symptoms	Hypoglycaemia; occasional vomiting from depot insulins	Of glycosuria and dehydration; abdominal pain and vomiting
Signs	Moist skin and tongue Full pulse Normal or raised BP Intraocular pressure—normal Shallow or normal breathing Brisk reflexes	Dry skin and tongue Weak pulse Low blood pressure Decreased Air hunger Diminished reflexes
Urine	No ketonuria No glycosuria, if bladder recently emptied	Ketonuria Glycosuria
Blood	Hypoglycaemia (< 60 mg/dl) Normal plasma bicarbonate	Hyperglycaemia (> 300 mg/dl) Reduced plasma bicarbonate

$$\text{Osmolality} = 2 (\text{Na}) + \frac{\text{Blood glucose}}{18} + \frac{\text{BUN}}{2.8}$$

- BUN is usually high (30–40 mg/dl) or blood urea is 60–80 mg/dl
- Serum ketones are not detectable
- Serum sodium may be high, normal or low
- Potassium levels may be high, normal or low
- Serum bicarbonate > 20 mEq/L and pH > 7.3
- Lactic acidosis may develop from underlying infection or other causes..



Management

- Supportive measures (treatment of shock and nursing for coma)
- Hourly blood glucose, electrolyte levels should be monitored.
- Fluid replacement
 - Initially fluid replacement is done to correct volume deficit.
 - Normal saline is given at a rate of 1 litre/hour and switched over to 0.45% saline once intravascular volume is corrected. It is given with caution in elderly and in patients with MI, heart failure and renal insufficiency.
 - After volume is restored and hyperglycemia has come down, 5% dextrose should be given to patients with persistent hyperosmolarity and hypernatraemia. Fluid is maintained at a rate of 100–250 ml/hour.
- Potassium should be replaced especially in patients on diuretics.
- Bicarbonate may be needed when pH is < 7.2

6. Insulin treatment:

Regular insulin 5–10 units IV, should be given when glucose is > 600 mg/dL and smaller doses are given later.

Insulin can also be given as an infusion or intramuscular injection. Insulin requirement is less when compared to DKA.

Lactic Acidosis

Patients with DM are vulnerable for disease like MI, sepsis, etc. Lactic acidosis is common in them and also during treatment with biguanides.

This is differentiated from DKA by plasma ketone levels and enzyme assays for lactate, acetoacetic acid, β hydroxy butyrate.

Lactic acidosis occurs in 2 general settings.

Type A—Vascular collapse + tissue hypoxia

Type B—No vascular collapse + No tissue hypoxia

Placenta is the only site where there can be lactic acidosis even in the presence of increased oxygen supply.

Lactic acidosis: Metabolic acidosis (pH < 7.2) with serum lactate > 5 mmol/L.



Causes

Group A (with Tissue Hypoxia)

Shock from any cause (septic shock, myocardial infarction, haemorrhage)

Respiratory failure

Cardiac failure

Poisoning with cyanide or carbon monoxide

Vigorous exercise (benign)

Convulsions.



Group B (without Tissue Hypoxia)

Diabetes mellitus
Hepatic failure
Severe infection
Pancreatitis.

Drugs

Phenformin
Sorbitol
Metformin
Fructose
Salicylates
Sodium nitroprusside
INH
Epinephrine and norepinephrine.

Toxins

Ethanol
Methanol.

Congenital enzyme defects

Glucose-6-phosphatase
Fructose 1, 6 biphosphatase
Pyruvate carboxylase
Pyruvate dehydrogenase
Leukaemia, lymphoma, solid tissue tumours (malignant).



Treatment

1. Treat the cause
2. Dichloroacetate has been tried
3. Bicarbonate is given for severe acidosis.

Long-term Complications of Diabetes

Diabetic Retinopathy

This is the most common cause for blindness in adults between 30 and 65 years.

The lesions can be broadly divided into

1. Simple/background retinopathy
2. Preproliferative retinopathy
3. Proliferative retinopathy.

Earliest change is increase in permeability of the capillaries which progresses to the formation of saccular and fusiform aneurysms.

Background Retinopathy without Maculopathy

It constitutes

- a. Venous dilatation
- b. Peripheral microaneurysms, small blot haemorrhages, small hard exudates

Lesions in Background Retinopathy

1. Increased capillary permeability
2. Capillary closure and dilatation
3. Microaneurysm (outpouching of capillaries)
4. Arteriovenous shunts
5. Dilated veins
6. *Haemorrhages (dot and blot):* It occurs in deeper layers of the retina and hence are round and regular; flame shaped haemorrhage is common in patients with hypertension.
7. *Cotton wool spots:* These are microinfarcts, i.e. non-perfused areas surrounded by a ring of dilated capillaries; a sudden increase in number is a bad prognostic sign.
8. *Hard exudates:* These are due to leakage of protein and lipids from damaged capillaries (Fig. 9.37).



Fig. 9.37: Flame shaped haemorrhages and hard exudates—hypertension with diabetes

Macular oedema should be suspected when loss of visual acuity is not corrected by glasses.

There is no immediate threat to vision. Hypertension, DM, should be controlled. Smoking and alcohol should be avoided. Regular fundus examination every 6–12 months is recommended.

Preproliferative Retinopathy

It constitutes

- a. Venous loops and beading
- b. Clusters/sheets of microaneurysms
- c. Small blot haemorrhages and/large retinal haemorrhages.
- d. Intraretinal microvascular abnormalities
- e. Multiple small exudates
- f. Macular oedema and decreased visual acuity
- g. Perimacular exudates ± retinal haemorrhages of any size.

This stage imposes mild threat to loss of vision. Rapid reduction of blood sugar results in development of soft exudates and haemorrhages and hence sugar has to be reduced gradually.

Proliferative Retinopathy

It constitutes

- Preretinal haemorrhage
- Neovascularisation
- Fibrosis
- Exudative maculopathy.

This stage is an emergency and urgent ophthalmological review is mandatory.

Proliferative retinopathy is more common in insulin treated patients than in those not treated with insulin.

The lesions are (Figs 9.38 to 9.40):

1. New vessel formation (due to retinal hypoxia secondary to capillary or arteriolar occlusion; new vessels form from mature vessels on the optic disc or the retina in response to areas of ischaemic retina)
2. Formation of retinal scar (retinitis proliferans)
3. Vitreal haemorrhage
4. Retinal detachment.

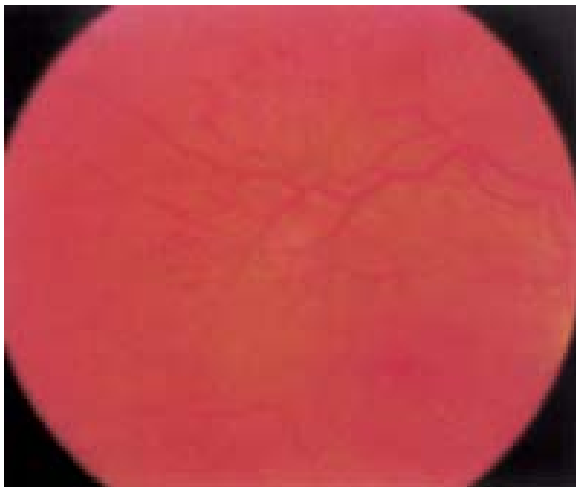

Fig. 9.38: Diabetic proliferative retinopathy—peripheral

The last two are serious complications of proliferative retinopathy causing sudden loss of vision in one eye.

Risk Factors for Diabetic Retinopathy

Common in young males; uncommon < 10 years regardless of the duration of Type 1 DM; frequency of retinopathy increases after 13 years. Changes occurring in puberty (like increase in insulin like growth factor I, growth hormone and sex hormones) BP and poor

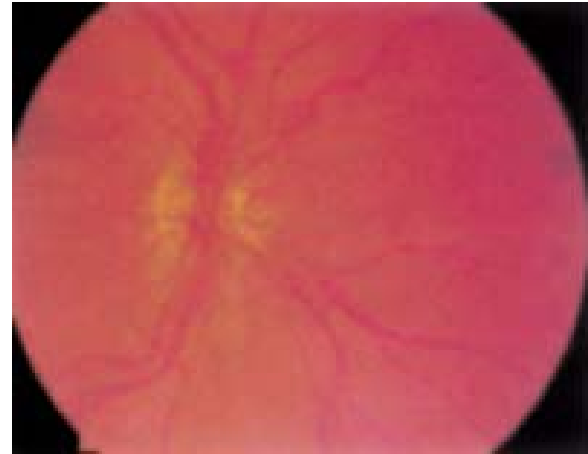

Fig. 9.39: Diabetic proliferative retinopathy well seen over the optic disc



Fig. 9.40: Proliferative retinopathy—Photocoagulation with laser

glycaemic control are thought to be responsible for increase in incidence of retinopathy. Increased insulin resistance, inadequate insulin dosage, poor compliance are the reasons for poor glycaemic control in post-pubertal teenagers.

Patients develop cataract at an early age.

Rubeosis Iridis

There is development of new vessels on the anterior surface of iris and it may obstruct anterior angle of eye leading to glaucoma.

Other Ocular Manifestations

- Cataract formation
- Dyskinetic pupils



Anatomical Classification of Neuropathy

Structure	Disorder	Aetiology	Signs and symptoms
A. Nerve root	Radiculopathy	Probably vascular	Pain and sensory loss along a dermatome
B. Mixed spinal or cranial nerve	Mononeuropathy	Probably vascular	Pain, weakness, loss of reflexes, sensory loss
C. Nerve terminals	Polyneuropathy	Metabolic	Glove and stocking sensory loss; minimal weakness, absent reflexes
D. Nerve terminal? Muscle?	Diabetic amyotrophy	Unknown	Anterior thigh pain; proximal muscle weakness
E. Sympathetic ganglion	Autonomic neuropathy	Unknown	Postural hypotension, anhidrosis, impotence, gastropathy, bladder atony, nocturnal diarrhoea

- Glaucoma
- Optic neuropathy
- Extra-ocular muscle paresis
- Floaters (pre-retinal or vitreous haemorrhage)
- Fluctuating visual acuity (Changing blood sugar level)

Treatment

1. Photocoagulation is the mainstay of treatment of diabetic retinopathy. It can be of two types namely xenon arc-white light, and laser beam (monochromatic blue or green light). It decreases the incidence of haemorrhage and scarring and is always indicated for neovascularisation. It is also used in the treatment of microaneurysms, haemorrhages and macular oedema even if the proliferative stage has not begun. Over a 2-week period, thousands of lesions (photocoagulation) are produced to diminish retinal demands for oxygen, thus decreasing the stimulus for neovascularisation.
2. Pars plana vitrectomy is utilized for treatment of nonresolving vitreal haemorrhage and retinal detachment (retinal tears, detachment, cataract, recurrent vitreal hemorrhage, glaucoma, infection, loss of the eye are complications of the surgery).
3. Duration and degree of glycaemic control of diabetes are the most important risk factors for retinopathy. Patients usually have no visual symptoms until

- serious late complications develop, which have no effective treatment. Hence, regular screening for retinopathy is mandatory in all diabetics.
4. Extracapsular extraction of lens with intraocular lens implantation is done for cataract. This surgery is also indicated when adequate assessment of fundus is precluded or when laser therapy to retina is prevented by presence of the cataract.

Limited Joint Mobility (LJM, Diabetic Hand Syndrome)

This is common in 15–30% of adolescents with Type 1 DM; A subset of those are 400–600% at greater risk of developing complications associated with hyperglycaemia. Patient keeps the hands together in prayer position; there is sclerodermatous, tight, waxy skin; fifth finger is involved early (cannot extend fully).

Diabetic Neuropathy

This is the most frequently encountered chronic complication of diabetes. The neuropathic disorder includes manifestation of the somatic and/or autonomic parts of the nervous system (Fig. 9.41).

Classification (Fig. 9.42)

1. Anatomical Classification
2. Clinical Classification

Different types of Diabetic Neuropathy

Features	Large fibre	Small fibre	Proximal motor	Acute mononeuropathy	Pressure palsies
Sensory loss	0 - +++	0 - ±	0 - ±	0 - ±	++
Pain	+ - ++	+ - +++	+ - +++	+ - +++	±
Tendon reflex	N - ↓↓↓	N - ↓	↓↓	Normal	Normal
Motor deficit	0 - +++	0	+++	++	++

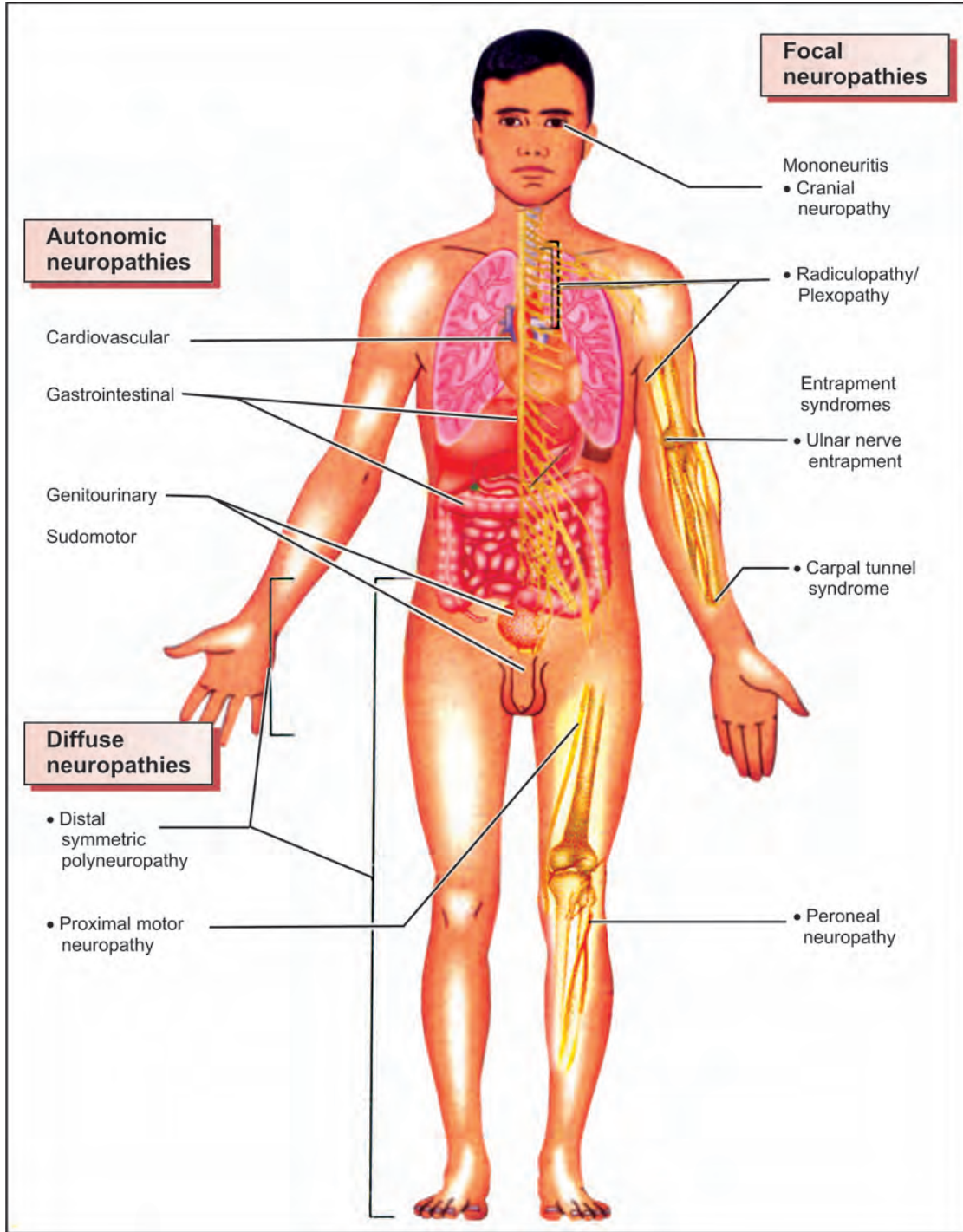

Fig. 9.41: Neuropathies in diabetes

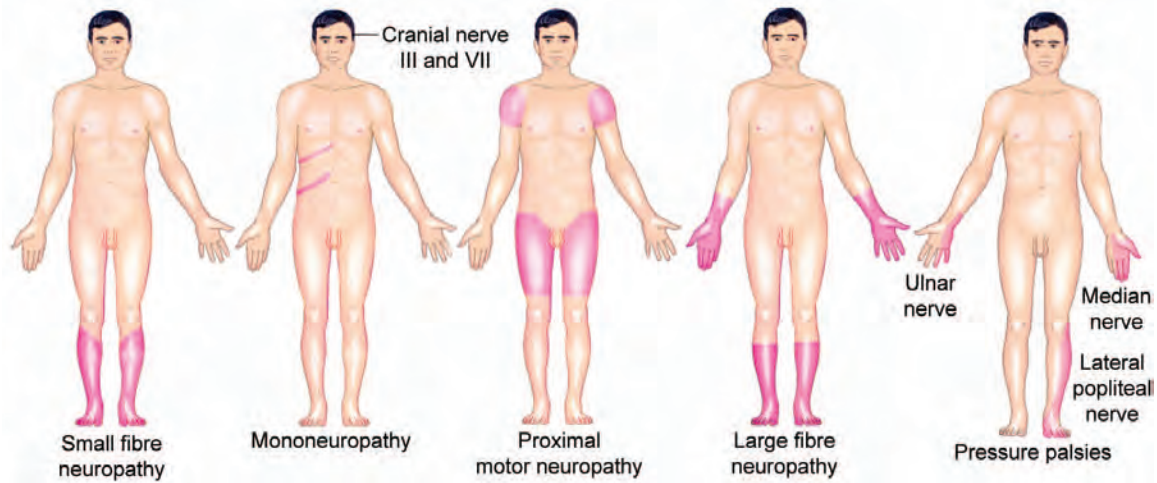

Fig. 9.42: Diabetic neuropathy

- a. Bilaterally symmetrical peripheral polyneuropathy
 - i. Sensory polyneuropathy
 - ii. Mixed sensory motor polyneuropathy
 - iii. Motor polyneuropathy.
- b. Symmetrical or asymmetrical proximal motor neuropathy
- c. Mononeuropathy (simplex or multiplex)
 - i. Cranial nerves
 - ii. Peripheral nerves.
- d. Abdominal polyradiculopathy
- e. Autonomic neuropathy.
 - Pain and paraesthesias – burning, lancinating, pins and needles, tingling, numbness, coldness
 - Feet more affected than hands
 - Acute < 6 months, Chronic > 6 months to years
 - Decreased autonomic function – decreased sweating and dry skin
 - Impaired blood flow – cold feet
 - Motor power and deep reflexes are intact
 - Risk of foot ulceration and gangrene
 - Early detection of impairment of touch and pricking sensation by monofilament and Waardenberg wheel tests
 - Topical application of capsaicin and clonidine are useful.

Factors Involved in the Aetiology and Pathogenesis of Diabetic Neuropathy

A. Metabolic

1. Hyperglycaemia
 - a. Sorbitol accumulation
 - b. Myo-inositol depletion
 - c. Sodium-potassium ATPase deficiency
 - d. Protein glycosylation
2. Lipid disturbances

B. Vascular

C. Others

1. Mechanical factors
2. Stress
3. Autoimmunity
4. Hereditary
5. Hypoglycaemia.

Small Fibre Neuropathy (C –fiber)

- Neuropathy of symptoms

Large Fibre Neuropathy

- Neuropathy of signs
- Impairment of vibration and position sense
- Delta type deep seated gnawing pain similar to toothache
- Sensory ataxia – (Waddling like duck)
- Wasting of small muscles of hands and feet
- Shortening of Achilles tendon – pessequinus
- Increased blood flow – hot foot
- Charcot's neuroarthropathy of different joints.

Classification of Autonomic Neuropathy in Diabetic Patients According to Systems Involved

1. Gastrointestinal disorders
 - Esophageal dysfunction
 - Stomach atony

- Gallbladder atony
- Small intestinal dysfunction
- Large intestinal atony
- Anorectal dysfunction
- 2. Genitourinary disorders
 - Bladder atony
 - Impotence
 - Retrograde ejaculation of semen into the bladder
 - Loss of testicular sensation
- 3. Cardiovascular disorders
 - Orthostatic hypotension
 - Heart rate abnormalities
 - Painless myocardial infarction
- 4. Respiratory control and airway tone disturbances
- 5. Peripheral autonomic disorders
 - Sudomotor and piloerector dysfunction
 - Vasomotor disturbances
 - Peripheral oedema
 - Orthostatic hypotension
- 6. Endocrine disorders
 - Hypoglycaemia
 - Defective epinephrine and glucagon counterregulatory response
 - Defective central perception
 - Norepinephrine (vascular) deficiency
 - Pancreatic polypeptide disturbances
 - Renin disturbances
- 7. Lacrimal gland disorders
- 8. Pupillary disorders
- 9. Special complications related to neuropathy
 - Diabetic foot disease
 - Neuropathic arthropathy (Charcot's joint)
 - Pseudotabes and pseudosyringomyelia
 - Entrapment neuropathies
 - Loss of visceral pain sense
 - Increased mortality (associated with autonomic neuropathy).

Tip Therm Test

TIP THERM is an early diagnostic testing device for symmetrical polyneuropathy which measures temperature sensitivity of the skin. TIP THERM is made of special polymer and metal alloys. The polymer side feels warmer and the metal alloy side cooler due to the thermal conductivity property of the materials.

Diabetic neuropathy can lead to the diabetic foot syndrome, resulting in ulceration. This distal symmetrical polyneuropathy involves both large and small nerve fibres. The large myelinated ($A\alpha$, $A\beta$) fibres detect vibration and sensation. The small myelinated ($A\delta$) and unmyelinated C fibres can detect thermal sensation.



Fig. 9.43: Tip therm test

Studies show abnormal small fibre function is usually affected before large fiber function

While temperature discrimination can be tested anywhere, it is best tested on the dorsal foot (Fig. 9.43). If sensation is not felt on the foot dorsum, try the test on the inside of the forearm. The patient should not watch the procedure so that objective results are obtained.

It was shown to have 100% specificity and 97.3% sensitivity in diagnosing diabetic neuropathy compared to biothesiometer testing:

Note: Testing vibratory sensation using 128 MHZ tuning fork at the base of the great toe and also the ability to sense touch with a monofilament (size of the monofilament- S 07/10g) are useful tests to detect moderately advanced diabetic neuropathy.

Monofilament Test

Early loss of protective sensation can be detected in the foot of the diabetic patients by using the 10 g monofilament (Fig. 9.44).

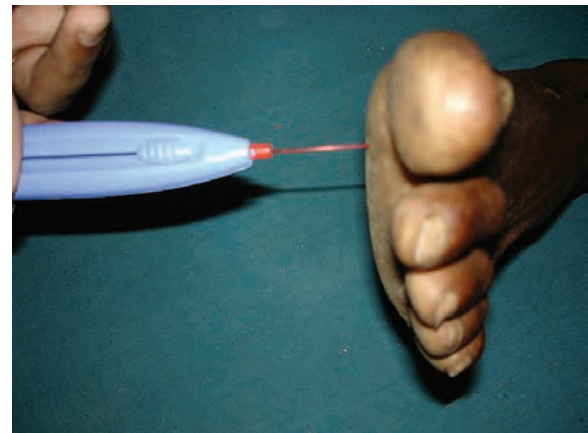

Fig. 9.44: Monofilament test



Fig. 9.45: Monofilament test

Ten sites are chosen and the monofilament is applied with enough pressure to bend the filament for the duration of not less than 2 seconds (Fig. 9.45). It is tested for three times at each site and it is enough if he answers correctly in 2 out of 3 applications. Failure to feel the monofilament in more than 4 sites denotes loss of protective sensation. The risk of ulcer formation is greater. This test is 95% sensitive and 80% specific.

Management of the Diabetic Neuropathies

General Measures

- a. Improvement in diabetic control
- b. *Aldose reductase inhibitors*: Sorbitol accumulation has a role in the pathogenesis of diabetic neuropathy and cataract; this sorbitol pathway can be shutdown by aldose reductase inhibitors.
- c. Relief of contributory factors like alcohol, ischaemia, hyperlipidaemia, malnutrition, uraemia, neurotoxic drugs.
- d. *Relief of nerve entrapment*: Constricting apparel, anti-inflammatory agents, surgical decompression, symptomatic drug treatment.
- e. Treatment of painful neuropathy:
 - i. Ibuprofen, sulindac are used; narcotic analgesics are not useful.
 - ii. Tricyclic antidepressants, phenothiazines (imipramine or amitriptyline 50–150 mg/day + fluphenazine 1 mg every 8 hours is used in the treatment of various neuropathic cachexia.
 - iii. Carbamazepine—up to 200 mg every 8 hours (prevents generation of action potentials)
 - iv. Capsaicin—topical application works by depleting the nociceptive neurotransmitter substance 'P' in unmyelinated sensory nerve terminals.

- v. Gabapentin -300 mg tid (maximum 1800 mg/day) or Pregabalin -75-150 mg bid (maximum 600 mg/day)
- vi. Alpha lipoic acid 600 mg/day IV for three weeks.
- vii. Pancreatic transplantation.
- f. Autonomic neuropathy
 - i. Gastroparesis—metoclopramide, cholinesterase inhibitors, domperidone, erythromycin
 - ii. Diabetic diarrhoea—clonidine, codeine, loperamide, diphenoxylate, kaopectate, cholestyramine, broad spectrum antibiotics, octreotide 50-75 µgm tid S/C
 - iii. Constipation—laxatives, metoclopramide
 - iv. Orthostatic hypotension—fludrocortisone, salt loading, sympathomimetics.
 - v. Diabetic cystopathy—cholinergics
 - vi. Retrograde ejaculation—brompheniramine maleate
 - vii. Gustatory sweating—anticholinergics, clonidine.

Supportive Measures, Prosthesis, Surgery

Foot care, foot wear
 Foot and leg braces
 Elastic stockings
 Physical therapy
 Small meals, gastroenterostomy
 Bladder massage (crede), self-catheterisation, bladder neck resection
 Orthopaedic surgical measures
 Penile prosthesis
 Anaesthetic precautions.



Treatment for Diabetic Erectile Dysfunction

Nonhormonal Therapy

Sildenafil citrate, a Phosphodiesterase 5 inhibitor is used at a dose of 50–100 mg (25 mg for men over 55 yrs) 1 hr before intercourse. It is contraindicated in patients with coronary artery disease and those taking nitrates.

α_2 blockers (yohimbine)

Tadalafil: It is very similar to sildenafil. It is a selective inhibitor of cyclic guanosine monophosphate (CGMP) and a specific phosphodiesterase 5 inhibitor (PDE 5). It is used in the dose of 10-20 mg one hour prior to sexual activity and the effect persists for 24 hours. Patients on nitrates or alpha blockers should avoid taking this drug.

Vardenafil- Similar to tadalafil and the dose is 10-20 mg one hour before sexual activity.

Alprostadil- (Prostaglandin E₁) 2.5-10 mcg is given by intracavernosal injection or intraurethral application for the management of erectile dysfunction. Painful erection lasting for more than 4 hours (priapism) and penile fibrosis are complications.

Hormonal Therapy

Hypogonadotrophic hypogonadism—parenteral testosterone 200 mg IM.

Hyperprolactinaemia or pituitary tumour—cessation of causative medications, bromocriptine, extirpative surgery.

Noninvasive Therapy

Vacuum erection devices

Intracavernosal injection of vasoactive agents (papaverine, phentolamine, PG-E).

Invasive Therapy

Penile prosthesis

Microvascular arterial bypass surgery.

Diabetic Foot

It is a complication of diabetes due to an interplay of a number of disturbances like large vessel disease, neuropathy, infection, poor wound healing and possibly small vessel disease also (microangiopathy).

- Sensory loss results in unrecognized trauma from poorly fitting shoes, thermal or hot water burns, penetrating objects, toe nail cutting, etc.
- Motor defects causing foot deformities, produce abnormal pressure points on weight bearing areas. Autonomic neuropathy results in poor arteriolar constriction and dilatation.
- Poor vasodilatation in response to heat or infection in combination with impaired sweating may compromise the local tissue microenvironment.
- Anhidrosis causes dry skin with fissures and cracks, predisposing to secondary infection.
- Denervation hypersensitivity (vasoconstriction in response to cold) may contribute to the development of diabetic foot ulcers.
- Hence, peripheral neuropathy is viewed as a primary underlying disturbance of diabetic foot lesions and vascular insufficiency is an important secondary factor.
- The ulcers are painless, with a punched out appearance. Foot is characteristically warm and

pulses are easily felt. Secondary infection is common and may lead to wet gangrene. X-ray may show underlying osteomyelitis with sequestra and destruction of bone.

- Repetitive stress of walking results in interosseous atrophy causing cocked up toes and thinning of fat pad over metatarsal head.

Foot infections in diabetic patients are classified into two categories.

1. *Non-limb-threatening infections* (superficial, lack systemic toxicity, minimal cellulitis less than 2 cm, ulceration not extending fully through the skin, lack of significant ischemia) *S. aureus* is the major pathogen involved.
2. *Limb threatening infections* (extensive cellulitis, lymphangitis, ulcers penetrating through the skin into the subcutaneous tissues, prominent ischemia).

Polymicrobial infections are common. *Staphylococcus aureus*, group B streptococci, enterococcus, and facultative gram-negative bacilli along with anaerobes are commonly implicated.

Clinical Features of Diabetic Foot

Primarily neuropathic	Primarily ischaemic
Warm	Cold
Bounding pulses	Absent pulses
Diminished sensation	Sensation intact
Pink skin	Skin blanches on elevation
Anhidrosis	-
Callous formation	-
Cracks and fissures	-
Painless ulceration	Painful ulceration
Digital ulceration	Digital gangrene
Charcot's joints	-
Wasting of interosseous muscles	-
Clawed toes	-
Neuropathic oedema	Oedema associated with cardiac decompensation



Management

1. *General instructions:* Patients are advised not to smoke. They should not walk on hard surfaces or sandy beaches especially with barefeet. They should not use adhesive tapes or chemicals for removing corns/callosities. They should wear properly fitting stockings. Shoes should be comfortable at the time of purchase. Leather shoes are preferred and they are best tried in the afternoon when feet are largest. Shoes with pointed tips should be avoided. They should cut their nails straight across using a nail cutter. Regular chiropody should be done every week to debride the lesion.

- Relieve high pressure area with bed rest and special footwear.
- If there is cellulitis, admit the patient and start on IV antibiotics (benzylpenicillin 600 mg/6 h IV and flucloxacillin 500 mg/6 h IV \pm metronidazole 500 mg/8 h IV or cefazolin IV).
For mild infections, oral clindamycin or cephalexin or cloxacillin for 2 weeks can be given.
- IV antimicrobial therapy is recommended for 10-12 weeks in the presence of osteomyelitis.

Absolute Indications for Surgery

- Abscess or deep infection
- Spreading anaerobic infection
- Osteomyelitis
- Severe ischaemia-gangrene/rest pain
- Suppurative arthritis.

Newer Treatment

- Platelet derived growth factor topical application for diabetic ulcer
- Living human skin equivalents – by tissue engineering technique.

Diabetic Nephropathy (DN)

About 50% of end stage renal disease are due to diabetic nephropathy. About 35% of patients with IDDM develop this complication. In NIDDM, prevalence varies from 15–50%.

There are 2 distinct pathologic patterns.

- Diffuse glomerulosclerosis*: This consists of widening of glomerular basement membrane and mesangial thickening.
- Nodular glomerulosclerosis*: There is deposition of PAS positive material in the periphery of glomerular tufts, (the Kimmelstiel-Wilson lesion) In addition, there is hyalinisation of afferent and efferent arterioles, 'capsular drops' in Bowman's capsule, fibrin caps and occlusion of glomeruli. Kimmelsteil-Wilson nodular glomerulosclerosis and capsular drops are pathognomonic of diabetic nephropathy.

Stages in Diabetic Nephropathy

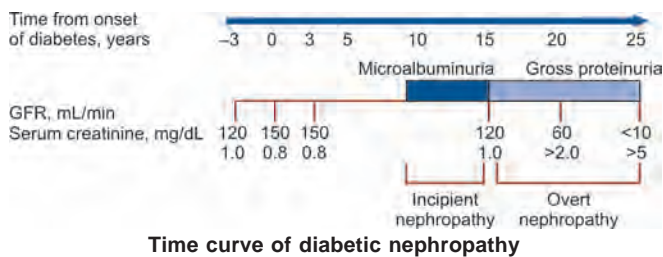

- Stage I Glomerular hyperfiltration and renomegaly
- Stage II Early glomerular lesions (expansion of mesangial matrix and thickening of glomerular basement membrane). Occurs 18–36 months after onset of IDDM.
- Stage III Microalbuminuria stage (incipient DN) with persistent hypertension of > 140–160/90 mm Hg.
Albumin excretion is in the range of 30–300 mg/day.
Albumin Excretion Rate (AER)—20–200 μ g/min.

Microalbuminuria is due to \downarrow concentration of anionic heparan sulfate-proteoglycan in the glomerular basement membrane. Diagnosis is by finding an AER > 15 μ g/min (30 mg/d) in 2–3 samples collected in a 6 month period.

Persistent leakage of protein greater than 500 mg/day is predictive of subsequent macroproteinuria.

- Stage IV Clinical nephropathy (macroproteinuria)
Once macroproteinuria begins, there is a steady decline in GFR of about 1 ml/min/month.

- Stage V End Stage Renal Disease
Azotemia develops usually after 10 years progressing to nephrotic syndrome and ESRD later.

Rx Treatment

- Angiotensin—converting enzyme inhibitors are useful in slowing progression of diabetic nephropathy, especially in microalbuminuric stage. They are useful in hypertensive patients with be diabetes.
If proteinuria persists after 3 months of therapy, the drug dose is increased until either the albuminuria disappears or the maximum tolerable dosage is reached.
If ACE inhibitors are contraindicated, then calcium channel blockers (non-dihydropyridin class—verapamil, diltiazem) can be used.
- Low protein diet
- Hyporeninemic hypoaldosteronism associated with renal tubular acidosis, may require alkalinizing solution (Shohl's solution); external K^+ should be avoided. Rarely fludrocortisone may be needed for treating hyperkalaemia.
- Plan for dialysis or renal transplantation in patients with end stage renal failure.

Pregnancy and Diabetes

In pregnancy, hormonal and metabolic effects increase the tendency to both ketoacidosis and hypoglycaemia (due to aggressive insulin therapy).

Effect of Diabetes on Pregnancy

The risk of congenital malformations is increased in infants born to diabetic mothers who have poor control of diabetes during the first trimester of pregnancy.

Polyhydramnios is common in poorly controlled diabetic women and can lead to preterm delivery. Maternal or fetal hyperglycaemia causes fetal hypoxia or asphyxia in the 3rd trimester. If preprandial blood glucose exceeds 150 mg/dl, careful foetal monitoring should be done. Foetal macrosomia is also common (birth weight > 90th percentile for gestational age or more than 4 kg); Intrauterine growth retardation can occur in diabetic women with vascular disease or persistent hypoglycaemia.

Other neonatal risks are respiratory distress syndrome, hypoglycaemia, hyperbilirubinaemia, hypocalcaemia and poor feeding.

Foetal Development

Incidence of congenital anomalies in infants of diabetic mothers is 6–12% whereas it is only 2% in nondiabetic populations. The congenital malformations found in children of diabetic mother are:

1. Caudal regression
2. Anencephaly
3. Spina bifida, hydrocephalus and CNS defects
4. Cardiac anomalies (TGV, VSD, ASD)
5. Anorectal atresia
6. Renal anomalies (agenesis, cystic kidney, ureter duplex)
7. Situs inversus.

Any intervention to reduce the incidence of major congenital anomalies should be done very early in pregnancy, i.e. between 5th and 8th week of gestation. This implies that PPBG should be maintained < 160 mg/dl prior to conception in diabetic women who plan pregnancy. Effective contraceptive counselling should also be given to them.

At 16–18 weeks, maternal serum alphafetoprotein should be measured and ultrasound study of the foetus should be performed at 20 weeks to rule out neural tube defects.

Echocardiography should be done at 22nd week in patients who have increased glycosylated haemoglobin early in pregnancy.

Ultrasound is also useful for finding out foetal growth and the length of gestation.

Maternal hyperglycaemia > 130 mg/dl is associated with excessive birth weight in infants of diabetic mothers (MACROSOMIA). This excess growth and fat deposition is due to foetal hyperglycaemia.

In contrast to macrosomia, the fetus of a woman with diabetes may have intrauterine growth retardation due to decreased uteroplacental perfusion; oligohydramnios is common.

Screening and Diagnostic Criteria for Gestational DM (O' Sullivan-Mahan Criteria)

Screening is done by plasma glucose measurement in the following way:

1. 50 gm oral glucose administration between 24th and 28th weeks without regard to time of day or time of last meal to all pregnant women who have not been identified as having glucose intolerance before 24th week.
2. Venous plasma glucose is measured 1 hr later.
3. A value of > 140 mg/dl indicates the need for a full diagnostic GTT.

Diagnosis of Gestational DM

1. 100 gm of oral glucose is given after overnight fasting of at least 8 hours, but not more than 14 hours, and after at least 3 days of unrestricted diet (> 150 gm of carbohydrate) and physical activity.
2. Venous plasma glucose is measured fasting and at 1, 2, and 3 hours after oral glucose (no smoking is allowed during test and patient should not undertake any physical activity).
3. Two or more of the following venous plasma glucose concentrations must be met or exceeded for a positive diagnosis.

Fasting	105 mg/dl (5.8 mmol/L)
1 hr	190 mg/dl (10.6 mmol/L)
2 hr	165 mg/dl (9.2 mmol/L)
3 hr	145 mg/dl (8.1 mmol/L)

Classification of Carbohydrate Intolerance in Pregnancy

Class	Classification criteria
Gestational DM (GDM)	Carbohydrate intolerance of varying severity with onset during present pregnancy.
GDM-Class A ₁	Fasting glucose normal for pregnancy; venous plasma < 105 mg/dl.
GDM-Class A ₂	Fasting glucose exceeds normal for pregnancy; venous plasma > 105 mg/dl on at least 2 occasions. Postpartum reclassification after 75 gm of oral glucose (can be normal, impaired glucose tolerance or diabetes mellitus).
Previous GDM	
* (Class A ₁ and A ₂)	Abnormality of glucose tolerance in a previous pregnancy, without DM having been diagnosed postpartum (Postpartum GTT having been normal, impaired or not performed).

* Criteria for Class A₁ and A₂ in previous GDM is similar to that of GDM



Pregestation Diabetes Mellitus

DM-type I

- a. Uncomplicated Absence of retinopathy, nephropathy, neuropathy, coronary artery disease or hypertension.
- b. Complicated Presence of one or more of the above complications.

DM-type II

- a. Uncomplicated
- b. Complicated.

Stages of Care in Diabetic Pregnancy before Conception

Establish preprandial blood glucose level (PPBG)

I trimester (PPBG > 9 mmol per L) or (160 mg/dl): Abortion risk and risk of congenital anomalies should be taken care of Monitor for ketonemia.

II trimester (PPBG > 7 mmol per L) or (130 mg/dl): Macrosomia is common; monitor for leucine, threonine, free fatty acid and total glucose values.

III trimester (PPBG > 7 mmol per L) or (130 mg/dl): Respiratory distress syndrome and stillbirths are common; monitor for ketonemia.

Postpartum (PPBG > 10 mmol per L) or (180 mg/dl): Counselling on lactation, contraception and child development are recommended.

Aim of therapy is to maintain a fasting plasma glucose of 60–100 mg/dl and a postprandial level of 100–130 mg/dl.

I. Dietary Management of Diabetic Women

- The key stone of management is the diet.
- Caloric intake should be less to prevent weight gain (> 4 pounds/month during first trimester and > 4 pounds during II and III trimester)
- Hypoglycaemic reactions should not be overtreated to minimize rebound hyperglycaemia.
- For moderate hypoglycemic symptoms—8 ounces of milk
- If blood glucose is < 60 mg/dl, 10 grams of fast acting carbohydrate (dextrosols or 4 ounces orange juice) should be given.
- For severe hypoglycaemia, patient must keep glucagon on hand and it should be given subcutaneously.

II. Insulin Therapy in Pregnancy

Most pregnant diabetics require at least 2 injections of a mixture of regular and intermediate insulin each day to

prevent fasting and postprandial hyperglycaemia. A 2/3rd of insulin can be given before breakfast and 1/3rd before supper. Fasting blood glucose is better controlled by delaying evening dose of intermediate insulin to bed time, which prevents nocturnal hypoglycemia.

III. Obstetric Management

1. a. Antepartum fetal surveillance is necessary during the 3rd trimester (26–34 weeks) to reduce the chance of stillbirth. Fetus is monitored by fetal activity determination recorded by pregnant woman.
- b. Fetal heart rate monitoring (stress and non-stress tests)
- c. Ultrasound.
2. The goal for delivery should be 38 weeks or later to reduce neonatal morbidity arising from a preterm labour.

Fetal pulmonary maturity should be assessed by amniotic fluid analysis for lecithin sphingomyelin ratio (L/S) or phosphatidyl glycerol (PG).

L/S ratio >3.5 or the presence of PG predicts the lowest risk for respiratory distress syndrome.

3. If the fetus is large (> 4200 gm), primary caesarean section should be done to avoid shoulder dystocia and birth trauma.

Otherwise, labour can be induced with continuous fetal heart rate monitoring. During labour, maternal blood sugar should be kept within 80–100 mg/dl by IV insulin (0.5–2 units/hour) along with Ringer lactate or normal saline as infusion.

4. Diabetic mothers should be encouraged to breastfeed. If breastfeeding is abruptly terminated, there may be a transient increase in insulin sensitivity.

Intrauterine contraceptive devices are effective in diabetic women and low dose sequential birth control pills do not harm glycemic and lipid profiles in diabetic women < 35 years of age.

Surgery and Diabetes

Surgery is a stressful condition either when performed electively or as an emergency. It results in the production of catabolic hormones cortisol, catecholamines, glucagon and growth hormone in normal persons as well as in diabetics.

Careful monitoring of blood glucose is necessary to

- a. Avoid hyperglycaemia and acute complications (DKA, hypoglycaemia)
- b. Allow a normal inflammatory response and wound healing.

Modification of Chronic Therapy

It is guided by patients usual treatment and by the nature of the surgery.

- i. Patients who are managed on diet alone often require no additional measures. For patients with fasting or postprandial hyperglycaemia > 200 mg/dl, human insulin is advised.
- ii. Patients using oral hypoglycaemic drugs should discontinue them on the day before the major surgery. They may need insulin whereas patients undergoing minor surgery, can be maintained on oral hypoglycemic drugs. However, oral drugs should be stopped on the morning of surgery and restarted when the patients start taking feeds adequately.
- iii. Patients who are treated with insulin require dosage adjustments. Hypoglycaemia is anticipated and dextrose solution should be available.

In Type 1 DM

Uninterrupted insulin administration is essential to prevent DKA. At least half the daily dose of insulin should be given on the day of surgery. Administration of 5% dextrose is helpful to limit lipolysis and ketogenesis in patients with restricted oral intake.

Periodic monitoring of glucose, electrolytes and urinary ketones should be done. For patients using conventional therapy, a dose of intermediate acting insulin should be given in the morning before minor surgery and then can be given twice daily. Hyperglycaemia is managed with supplements of regular insulin given every 4–6 hours till oral intake is resumed.

In patients using MDII or CSII, basal insulin given preoperatively, is continued during perioperative period.

In Type 2 DM

Patients requiring large dose of exogenous insulin (> 50 units/day), are given insulin in preoperative and immediate postoperative period. 2/3rds of the dose is given as intermediate acting insulin and the rest is given as short-acting insulin.

- iv. *IV insulin infusion therapy:* Very stressful procedures like coronary artery bypass, renal transplant, etc. may require insulin infusion, during pre (0.5–1 unit/hour), intra and postoperative periods till the oral drugs are replaced, or when insulin can be given subcutaneously.

Emergency surgery may be needed despite severe hyperglycaemia, DKA, or NKHS; IV insulin infusion is preferred along with replacement of intravascular volume.

In the perioperative period, assess for chronic complications of diabetes, i.e. patients with cardiovascular disease and autonomic neuropathy are susceptible for asymptomatic MI. Decubitus ulcer is common in patients with neuropathy especially when they are immobilized for a longer period. Enteropathy can alter GI responses to surgery and anaesthesia.

Guidelines for Perioperative Diabetes Management with IV Insulin Infusion

Twenty-five units of regular human insulin in 250 ml of normal saline is connected to a perioperative maintenance fluid line (5% dextrose at a rate of 100 ml/hr).

Blood glucose mg%	Insulin units/hr	Insulin ml/hr
<80	0	0
81 – 100	0.5	5
101 – 140	1	10
141 – 180	1.5	15
181 – 220	2	20
221 – 260	2.5	25
261 – 300	3	30
301 – 340	4	40
>341	5	50

- If blood glucose becomes less than 80 mg%, stop insulin and administer 50% dextrose IV bolus. Once blood sugar becomes > 80 restart insulin infusion.
- Insulin needs are decreased in patients on treatment with diet or oral agents or those requiring < 50 units/day and in those with endocrine deficiencies.
- Insulin needs are increased in patients with obesity, sepsis, steroid therapy, renal transplant, coronary artery bypass.

Preoperative Assessment

1. Assess cardiovascular function and renal function
2. Check for signs of neuropathy (particularly autonomic)
3. Assess diabetic control (Estimation of Hb A_{1c}, monitor preprandial blood glucose 4 times daily)
4. Review treatment of diabetes.
Replace long-acting with intermediate insulin.
Stop sulfonylureas (long acting) or biguanides (metformin) and replace with insulin if necessary.

Criteria for Simultaneous Pancreas-Kidney Transplantation

Criteria for Inclusion

1. Insulin-dependent diabetes mellitus
2. Age 18–55 years
3. Established diabetic nephropathy (serum creatinine > 2 mg/dl)



Criteria for Exclusion

1. Insufficient cardiac reserve (by ECHO, perfusion scan)
2. Peripheral vascular disease
3. Major psychiatric illness
4. Substance abuse (drugs, alcohol)
5. Cancer
6. Active infection.

Hypoglycaemia in Adults

Hypoglycaemia is a biochemical abnormality, not a disease.

Criteria for Diagnosis

Glucose level	Fasting state	Fed state
Plasma glucose	< 60 mg/dl	< 50 mg/dl
Whole blood	< 50 mg/dl	< 40 mg/dl

Whipple's triad for the diagnosis of hypoglycaemia

1. Symptoms of hypoglycaemia
2. Low plasma level of glucose
3. Relief of symptoms after raising the level of plasma glucose.
Random blood glucose level of < 50 mg/dl suggests hypoglycaemia.

Glucose Homeostasis

Most important organ which consumes glucose is the brain (requirement 100 gm/day). Other organs which use glucose as the major fuel are RBCs (35 g/day) and muscle (30 g/day). Other tissues use predominantly free fatty acids or ketone bodies.

Glucose production is mainly by the liver during short fasts. Glucose is produced by two separate pathways.

1. *Glycogenolysis*: Seventy-five per cent of glucose production is by this pathway especially during an overnight fast.

2. *Gluconeogenesis*: It is the synthesis of new glucose from noncarbohydrate sources. The three major substrates are lactate, derived from peripheral tissues, amino acids released by muscle and glycerol derived from the breakdown of triglycerides in adipose tissue. Only 25% of hepatic glucose production derives from gluconeogenesis after an overnight fast. When the contribution from glycogenolysis ceases, gluconeogenesis becomes dominant as the period of fasting lengthens.

Obligate glucose consumers continue to function normally even after prolonged fasting because of powerful defense mechanisms.

During fasting the glucose level decreases (by 15–20 mg/dl) and the insulin levels decrease and get stabilized at a lower level. After a feed there is an increase in blood glucose concentration closely followed by a rise in blood insulin concentration. This response is exaggerated in obese than in lean subjects. Fifty per cent of the insulin undergoes degradation in the liver and the rest, circulate and act on 3 specific receptors on liver, muscle and adipose tissue.

Hypoglycaemia is better tolerated by females. They do not develop symptoms till the blood glucose falls to 35–40 mg/dl.

Ten per cent of glucose is converted to glycogen and stored in the liver.

Hormonal Response to Hypoglycaemia

- a. *In Normal Persons*: Levels of epinephrine, norepinephrine and glucagon increase quickly whereas levels of cortisol and growth hormone increase slowly during hypoglycaemia. This response is brought about by sensitising glucose receptors in hypothalamus and it continues for 8–10 hours.
- b. *In Type I Diabetes*: First 5 years after the onset of Type 1 DM, glucagon response to hypoglycaemia is lost. After 10 years, the epinephrine response is also lost even in the absence of autonomic neuropathy. The other counter regulatory hormones continue to act. This results in absence of recognition of hypo-

Hormone	Onset of		Effects
	Secretion	Action	
Epinephrine, Norepinephrine	Rapid	Rapid	Inhibits glucose utilisation by muscle; increases hepatic gluconeogenesis; stimulates glucagon secretion; inhibits insulin secretion; stimulates hepatic glycogenolysis
Glucagon	Rapid	Rapid	Increases hepatic glycogenolysis; increases hepatic gluconeogenesis
Cortisol	Delayed	Probably immediate	Increases hepatic gluconeogenesis; inhibits glucose utilisation by muscle
Growth hormone	Delayed	Delayed	Inhibits glucose utilisation by muscle; increases hepatic gluconeogenesis

glycemic symptoms produced by epinephrine and they become more prone for hypoglycaemia when on insulin therapy. Because of this, patients suffer from “hypoglycaemia unawareness” due to impaired, glucagon, epinephrine and autonomic nervous system response.

- c. *In Type 2 Diabetes*: Levels of counter regulatory hormones remain normal.

Signs and Symptoms of Hypoglycaemia

- Adrenergic Symptoms** (Increased activity of the autonomic nervous system, triggered by a rapid fall in glucose level):
Weakness, sweating, tachycardia, palpitations, tremor, nervousness, irritability, tingling of mouth and fingers, hunger, nausea, vomiting.
- Neuroglucopenic Symptoms** (due to decreased activity of CNS, requires an absolutely low level of glucose):
Headache, hypothermia, visual disturbances, mental dullness, confusion, amnesia, seizures, coma.
- Relationship between plasma glucose and signs of hypoglycaemia.**

90–75 mg%	Inhibition of insulin secretion
75–60 mg%	Glucagon, epinephrine and GH secretion
60–45 mg%	Cortisol secretion, cognitive dysfunction
45–30 mg%	Lethargy
30–15 mg%	Coma, convulsions
<15 mg%	Permanent brain damage and death

Fasting Hypoglycaemia



Causes

Most common cause is treatment by insulin or sulfonylureas in a known diabetic.

The causes can be remembered by the mnemonic EXPLAIN.

- E**x Exogenous drugs—alcohol binge, insulin, sulfonylureas, quinine, salicylates, sulfonamide
- P** Pituitary insufficiency
- L** Liver failure and inherited enzyme defects (glucose-6-phosphatase, pyruvate carboxylase, fructose 1, 6-diphosphatase, glycogen synthetase, etc.)
- A** Addison’s disease
- I** Increased insulin secretion
Islet cell tumour
Ectopic insulin secretion
- N** Nonpancreatic neoplasm

Other causes are:

- Renal failure
- Insulin autoantibodies
- Insulin receptor autoantibodies
- Sepsis
- Falciparum malaria
- Congestive heart failure.

Fasting hypoglycaemia is gradual and prolonged. The adrenergic response is reverted by glucose or meal.

1. Drugs

Insulin is the most common drug causing hypoglycaemia. Sulfonylurea agents are the next common. Many other drugs potentiate the action of sulfonylureas. They are sulfonamides, chloramphenicol, clofibrate, dicoumarol, quinine, MAO inhibitors, phenylbutazone, and oxytetracycline.

Salicylates, pentamidine, propranolol may cause hypoglycaemia when taken alone.



Treatment

- Blood should be taken for determination of glucose, insulin, C-peptide and sulfonylureas.
- Treatment should be started before biochemical results arrive. The response is dramatic.
- Initial treatment 50 ml of 50% glucose followed by constant IV glucose infusion until the patient is able to eat a meal. Hepatic glycogen repletion is not effective with small quantities of IV glucose and hence the importance of meal is stressed.
- Hypoglycaemia from sulfonylureas may last for prolonged periods up to a few days and relapses are common. If glucose infusion is stopped early, patient may lapse back into coma. The prolonged effect of hypoglycemia may be due to drug interactions, hepatic or renal disease.
- In hypoglycaemia due to insulin, glucagon (1 mg subcutaneously) can be given. In addition to stimulating hepatic glycogenolysis, it stimulates insulin secretion and hence it should not be given for sulfonylurea induced hypoglycaemia.
- Patients who fail to regain consciousness may have cerebral oedema and they require treatment with mannitol or dexamethasone.

2. Factitious Hypoglycaemia

This is an unusual form of drug induced hypoglycaemia. Patients surreptitiously take insulin or occasionally sulfonylureas.



Differential Diagnosis of Insulinoma and Factitious Hyperinsulinism

Test	Insulinoma	Exogenous insulin	Sulfonylurea
Plasma insulin	High (upto 200 mU/mL)	Very high (more than 100 mU/mL)	High
Insulin/glucose ratio	High	Very high	High
Proinsulin	Increased	Normal or low	Normal
C-peptide	Increased	Normal or low	Increased
Insulin antibodies	Absent	± Present	Absent
Plasma or urine sulfonylurea	Absent	Absent	Present

Hypoglycaemia may be induced by exogenous/endogenous insulin. It is differentiated by detecting high levels of C peptide in endogenously induced hypoglycaemia.

3. Ethanol

Ethanol produces hypoglycaemia by the following mechanism. It inhibits gluconeogenesis and occurs commonly in malnourished chronic alcoholic in whom glycogen stores in the liver are depleted.

4. Non β -Cell Tumour

Non β -cell tumours associated with hypoglycaemia are:

- Large mesenchymal tumours (50%)
- Hepatocellular carcinomas (25%)
- Adrenal carcinomas (5–10%)
- Gastrointestinal tumours (5–10%)
- Lymphomas (5–10%)
- Miscellaneous tumours (kidney, lung, anaplastic carcinomas, carcinoid).

The mechanism of hypoglycaemia is unclear. In rare instances, production of insulin or insulin like growth factor II (IGF-II) may be the cause.

Adrenal Carcinomas

Although rare, these are associated with hypoglycaemia commonly. Removal of the adrenal tumour is the treatment of choice.

Frequent feeding and glucocorticoids are also found to be helpful.

5. Hepatic Failure

In hepatic failure, hypoglycaemia occurs only when the liver is severely compromised (fulminant hepatic failure). Hourly blood glucose monitoring is mandatory and prompt correction should be done till the liver regenerates.

Hypoglycaemia occurring in this situation is a bad prognostic sign.

6. Adrenal Insufficiency

In this situation, decreased cortisol synthesis results in decreased gluconeogenesis and decreased hepatic glucose production.



Treatment

IV glucose as a bolus + 100 mg cortisol bolus followed by maintenance dose of steroids.

7. Beta Cell Tumour (Insulinomas)

These are rare tumours. Correct diagnosis is important as they are curable and if undetected for long periods of time, may develop neuropsychiatric sequelae. Glucose levels fall slowly and adrenergic response is often lacking (hypoglycaemia unawareness). They tend to present with confusion, transient neurologic syndromes, visual disturbances, personality changes, convulsions, coma and may lead to death. Weight gain is common in some of the patients. It is commonly associated with multiple endocrine neoplasia Type I.

This condition is diagnosed by the presence of Whipple's triad (fasting hypoglycaemia, symptoms of hypoglycemia, and immediate recovery after IV glucose) along with increased C-peptide and insulin levels and absent insulin antibodies or plasma/urine sulfonylureas.

Diagnostic Tests for Insulinomas

- Suppression of insulin secretion by fasting:* Fasting in normal subjects results in proportional fall of glucose and insulin (I/G ratio decreases).

In insulinoma, insulin is not suppressed and Insulin (microunit/mL)/Glucose (mg/mL) ratio increases. Ratios above 0.3 are diagnostic. Blood samples for glucose and insulin are drawn after the overnight fast and then every 2–4 hours after that. About two-thirds of patients will have hypoglycaemia symptoms within 24 hours of food deprivation. Another 25% will experience symptoms in the next 24 hours. The third day of fasting is required in 5% of patients who have insulinomas.

Protocol for 72 Hours Fast

- a. Onset is time of last food.
 - b. Nothing by mouth except noncaloric beverages.
 - c. Patient should be active during waking hours.
 - d. Measure plasma glucose, insulin, C-peptide every 6 hours, every hourly when blood glucose is < 60 mg/dl.
 - e. End fast if plasma glucose is 45 mg/dl or less and when patient has symptoms.
 - f. At the end of fast, measure plasma glucose, insulin, C-peptide, sulfonyleurea and ketone bodies.
 - g. Give glucagon 1 mg IV and measure plasma glucose every 10 minutes for 3 times.
2. *Measurement of proinsulin content along with insulin content* by radioimmunoassay of the fasting plasma is done. In insulinoma, proinsulin constitutes > 20% of insulin.
- Ratio of insulin to proinsulin in normal individuals is 6 : 1. In insulinoma, the ratio is 1 : 1 whereas in sulfonyleurea induced hypoglycaemia, the ratio is 10 : 1.
3. *C-Peptide Level*: It increases in equimolar concentration as that of insulin.
4. *Glucagon test*: After an overnight fast, give glucagon 1 mg IV and if the peak insulin response is more than 130 μ g/ml, the test is positive.
5. *Localisation of tumour by CT, MRI, radionuclear scan* is done if the tumour is more than 2 cm in size. If the tumour is less than 2 cm in size, pancreatic arteriography and CT with contrast can be used.

**Treatment**

Medical: Acute treatment is by giving IV glucose infusion till plasma levels of glucose reach normal range. Drugs which act by increasing blood glucose level.

- a. Oral diazoxide 300–1200 mg/day along with a diuretic (thiazide) to compensate for salt retaining property of diazoxide
- b. Phenytoin
- c. Chlorpromazine
- d. Propranolol
- e. Verapamil
- f. Octreotide (100–600 mg/day subcutaneously).

Drug of choice for metastatic islet cell carcinoma is streptozotocin and doxorubicin or L-asparaginase or mithramycin.

Surgical: Surgery is the definitive treatment. Detectable tumours can be resected. If there is no detectable tumour, stepwise distal pancreatectomy is done until frozen

section or blood glucose shows that all the tumour is removed.

8. Renal Failure

Poor dietary intake, decreased gluconeogenesis, and increased peripheral utilisation of glucose are the reasons for hypoglycaemia.

**Treatment**

Frequent feeding and glucocorticoids (15–20 mg prednisolone) sometimes. In patients with end stage renal disease, hypoglycaemia is a poor prognostic sign and the patients may die within 1 year.

9. Insulin Autoantibodies

Occasionally a patient may spontaneously develop antibodies to insulin even though he has never received insulin which leads to hypoglycaemia. This is due to binding of large amounts of endogenous insulin with subsequent release of free insulin at inappropriate time. Unusual cause for hypoglycaemia may be as a part of endocrine syndrome as occurs in rheumatoid arthritis, systemic lupus erythematosus, or Graves' disease.

10. Insulin Receptor Autoantibodies

This occurs usually in females. Patients have a syndrome of insulin resistance and acanthosis nigricans. Patients have raised ESR, anti-DNA antibodies, increased gamma globulin and decreased complement levels.

11. Sepsis

Hypoglycaemia is occasionally seen in both gram-positive and gram-negative sepsis.

12. Falciparum Malaria

In malaria, hypoglycaemia is due to increased glucose utilisation by parasitized RBCs. It occurs commonly in severely ill, fasting patients especially children.

13. Congestive Heart Failure

Patients have weight loss, anorexia, decreased cardiac output, and mild hepatic dysfunction. In CCF, hypoglycaemia is due to decreased delivery of gluconeogenic substrates to the liver as a result of poor appetite and diminished hepatic blood flow.

Fed (Reactive) Hypoglycaemias

In fed hypoglycaemia, symptoms are mainly adrenergic. The onset is rapid and transient. It is usually reversed



by the normal hormonal responses. Administration of adrenergic antagonists results in disappearance of signs and symptoms but is usually not necessary.



Causes of Fed Hypoglycaemias

1. Hyperalimentation
2. Impaired glucose tolerance
3. Idiopathic reactive hypoglycaemia
4. Adrenal insufficiency*
5. Beta-cell tumours (insulinomas)*
6. Insulin autoantibodies*
7. Hereditary fructose intolerance
8. Galactosemia.

*Also cause fasting hypoglycaemias.

Oral Glucose Tolerance Test

Alimentary hyperglycaemia is now called hyperalimentation. Early diabetes is now called impaired glucose tolerance; functional hypoglycaemia is now called idiopathic reactive hypoglycaemia.

Abnormally high glucose levels in the early part of oral GTT indicates impaired glucose tolerance and a normal early levels of glucose indicates idiopathic reactive hypoglycaemia.

Hyperalimentation

It is common in patients who have undergone gastric surgery. The normal relationship between the stomach and the small intestine is altered. The entry of the stomach contents into the duodenum is rapid and the rate of absorption of glucose is also increased causing hyperglycaemia.

In response to this, there is an increased insulin secretion which causes hypoglycaemia.

Impaired GTT

The explanation for late hypoglycaemia occurring several hours after food, is due to the high insulin level. This is because of lack of influx of enough carbohydrate from the intestinal tract at this time to buffer the effect of the hormone.

Idiopathic Reactive Hypoglycaemia

The GTT shows the normal early concentration and later low levels of glucose.

Diagnostic Criteria

- a. Decreased glucose concentration must be documented

- b. Signs and symptoms must occur at the time of hypoglycaemia
- c. Signs and symptoms must improve shortly after a meal
- d. This pattern should occur regularly.



Treatment of Reactive Hypoglycemia

1. Diet

Diet is the mainstay of treatment in the fed hypoglycaemics. Avoid simple or refined carbohydrates.

For obese patients weight reduction is advised and carbohydrate is reduced to 35–40% of the total calories. Multiple small feedings are advised for patients with hyperalimentation.

2. Drugs

- a. Proprantheline bromide—7.5 mg half an hour before food
- b. Phenytoin—100 to 200 mg tid; It acts by inhibiting insulin secretion.
- c. Propranolol—10 mg half an hour before food.
- d. Calcium channel blockers
- e. Acarbose—(Glucosidase inhibitor).

3. Surgery

In patients with hyperalimentation, a reversed jejunal segment near the gastric outlet prevents the rapid release of glucose into the circulation.

Hyperlipoproteinaemias

Hyperlipoproteinaemias are due to disturbances of lipid transport that result from accelerated synthesis or reduced degradation of lipoproteins that transport Cholesterol and Triglycerides.

Structure

Lipoproteins are globular proteins with an inner lipid core and an outer protein coat.

The inner hydrophobic core consists of varying amounts of:

1. Cholesterol esters
2. Triglycerides.

The outer hydrophilic coat is made up of varying amounts of:

1. Phospholipids
2. Unesterified cholesterol
3. Apoproteins.

Classification of Lipoproteins and their Composition

A. Chylomicrons and their Remnants

1. Major lipid: exogenous (dietary) triglycerides
2. Apoproteins: AI, AII, B48, CI, CII, CIII, E
3. Electrophoretic mobility: remains at the origin.

B. VLDL (Very Low Density Lipoprotein)

1. Major Lipid: endogenous triglycerides
2. Apoproteins: B48, CI, CII, CIII, E
3. Electrophoretic mobility: slow pre-beta.

C. IDL (Intermediate Density Lipoprotein)

1. Major Lipid: cholesterol esters and triglycerides
2. Apoproteins: B100, CIII, E
3. Electrophoretic mobility: slow pre-β.

D. LDL (Low Density Lipoprotein)

1. Major lipid: cholesterol esters
2. Apoproteins: B100
3. Electrophoretic mobility: β.

E. HDL (High Density Lipoprotein)

1. Major lipid: cholesterol esters
2. Apoproteins: AI, AII
3. Electrophoretic mobility: alpha.

Low HDL-C (< 40 mg/dL) may be due to a genetic disorder or to secondary causes.

Primary disorders:

- Familial hypoalphalipoproteinaemia
- Primary hypertriglyceridaemias
- Fish-eye disease
- Tangier disease
- Lecithin-cholesterol acyl transferase (LCAT) deficiency

Secondary disorders:

- Cigarette smoking
- Obesity
- Lack of exercise
- Androgens and progestational agents
- Anabolic steroids
- Betablockers
- Hypertriglyceridaemia

Low HDL levels are associated with increased risk of cardiovascular disease.

Correct the precipitating factors. Niacin is the most effective agent for increasing HDL. 10-20% increase

can occur with fibrates only in patients with elevated TGL.

F. Lp (a) [Lipoprotein Little a]

It consists of an apoprotein (a) molecule bound by sulfhydryl link to the apolipoprotein B moiety of LDL particle. Apoprotein (a) has homology with plasminogen and may inhibit fibrinolysis by competing with plasminogen. Thus it provides an important link between haemostasis and blood lipids and plays a major role in atherogenesis.

Normal serum level is 0-3 mg/dl.

Elevated levels of lipoprotein (a) above 30 mg/dL are associated with increased risk for atherosclerotic cardiovascular disease. Moderate reduction is possible only with niacin and the primary approach to therapy is reduction of LDL-C.

Fredrickson's Classification of Hyperlipoproteinaemias

Types	Major Elevation in Plasma	
	Lipoprotein	Lipid
Type I	Chylomicrons	TGL
Type 2a	LDL	Cholesterol
Type 2b	LDL+ VLDL	TGL + Cholesterol
Type 3	Chylomicron remnants + IDL	TGL + Cholesterol
Type 4	VLDL	TGL
Type 5	Chylomicrons + VLDL	TGL + Cholesterol

Primary Hyperlipoproteinaemias Resulting from Single Gene Mutations

A. Familial Lipoprotein Lipase Deficiency

- It is an autosomal recessive disorder.
- The conversion of chylomicron to chylomicron remnants is defective. The disease presents in infancy or childhood with recurrent attacks of abdominal pain. The pain is due to pancreatitis.
- *Eruptive xanthomas* occurs as yellowish papules with an erythematous base in the buttocks and other pressure sensitive areas.
- As TGL is deposited in the RE system, there is hepatomegaly, splenomegaly and foam cell infiltration of the bone marrow.
- *Lipemia retinalis* is due to excess of chylomicrons in the serum of the retinal vessels.

There is no acceleration of atherosclerosis in this condition
Pathogenesis of pancreatitis: The circulating chylomicrons cause inflammation of the pancreas as they pass through its capillaries. There is release of pancreatic lipase, which



splits the TGL into toxic products like lysolecithin, etc. which sets the stage for the onset of the pancreatitis.

B. Familial Apoprotein CII Deficiency

- A rare autosomal recessive disorder
- This disorder resembles familial lipoprotein lipase deficiency
- The lack of apoprotein CII results in ineffective action of lipoprotein lipase, because CII is the cofactor for this enzyme
- Type-I or Type-V hyperlipoproteinaemia may occur.

The differences between this disorder and familial lipoprotein lipase deficiency include:

- Later onset of symptoms
- Greater elevation of VLDL
- Rare incidence of eruptive xanthomas.

C. Familial Type-3 Hyperlipoproteinaemia (Dysbetalipoproteinaemia)

Inherited as an autosomal recessive disorder, characterised by the presence of a defective apoprotein-E. There is elevation of chylomicron remnants and IDL. They do not manifest before 20 years of age.

Two unique xanthomas seen in this disease are:

- Xanthoma striae palmaris
- Tuberous/tuberoeruptive xanthomas over knees and elbows.

Severe fulminant atherosclerosis involves the coronary, carotid arteries and the abdominal aorta.

Patients often develop myocardial infarction, strokes and/or peripheral vascular disease.

Patients often have hypothyroidism, diabetes mellitus and/or obesity complicating this disorder.

Broad beta band (type-3 pattern) is seen in electrophoresis.

D. Familial Hypercholesterolemia

- Inherited as an autosomal dominant disorder
- A very common genetic disorder affecting 1 in 500 persons
- This is due to deficiency of LDL receptors
- Heterozygotes show a 2 to 3-fold rise in LDL-cholesterol while homozygotes have a 7 to 8-fold rise in LDL-cholesterol
- Symptoms in heterozygotes develop after the 3rd decade while homozygotes usually die within 20 years of age
- Premature atherosclerosis occurs.

Tendon xanthomas are diagnostic but occurs only in 75% of the patients. In homozygotes a unique type of xanthoma, planar cutaneous xanthomas, are seen at

birth. Arcus senilis and xanthelasma also occur but are not unique to this disorder. Slender body habitus is the rule in this disorder.

Differential diagnosis include:

- Polygenic hypercholesterolaemia and
- Multiple lipoprotein-type hyperlipidaemia.

E. Polygenic Hypercholesterolaemia

- Five per cent of general population have serum cholesterol exceeding the 95th percentile.
- If we consider 20 persons having hypercholesterolaemia, 17 will have this disorder while 2 will have familial hypercholesterolaemia.

This disorder can be differentiated from the latter by the following

- Only 10% have a positive family history in contrast to 50% with the latter two disorders
- Tendon xanthomas occur only with familial hypercholesterolaemia.

F. Multiple Lipoprotein-Type Hyperlipidaemia

- Inherited as an autosomal dominant disorder.
- Manifests as premature atherosclerosis.
- The affected may have type-2a, type-2b or type 4 hyperlipidaemias
- Tendon xanthomas do not occur.
- The serum cholesterol levels seldom exceed 400 mg per dL.

G. Familial Hypertriglyceridaemia

- Inherited as an autosomal dominant disorder.
- VLDL levels are raised.
- The affected individuals usually manifest with hypertriglyceridaemia during late puberty or early adulthood.
- The incidence of atherosclerosis is increased, but it is not definitely known whether this is due to hypertriglyceridaemia *per se*.
- Xanthomas are not a characteristic feature of this disorder.
- This disease is associated with acute exacerbations, during which period the patient may have serum TGL levels exceeding 1000 mg/dl. During these exacerbations the patient may lapse into Type-5 hyperlipidaemia and develop pancreatitis and/or eruptive xanthomas.

The following conditions predispose to the development of these exacerbations:

- Poorly controlled diabetes mellitus
- Alcoholism
- Oestrogen containing contraceptive pills
- Hypothyroidism.

There is an increased prevalence of obesity and diabetes in these people.

H. Familial Hyperalphalipoproteinaemia

- This is inherited as an autosomal dominant trait and also as a multifactorial disorder in some cases
- Increased levels of HDL are seen
- The longevity of these cases is greater than the longevity of the general population.

Secondary Hyperlipoproteinaemias

A. Endocrine and Metabolic Causes

1. Type-4 hyperlipoproteinaemia is seen in
 - a. Diabetes mellitus
 - b. Von-Gierke's disease
 - c. Acromegaly.
2. Type-2a hyperlipoproteinaemia is seen in
 - a. Cushing's syndrome
 - b. Hypothyroidism
 - c. Anorexia nervosa
 - d. Acute intermittent porphyria.
3. Type-2b hyperlipoproteinaemia is seen in
 - a. Cushing's syndrome
 - b. Isolated GH deficiency.

B. Drug Induced

1. Type-2a hyperlipoproteinaemia is seen with
 - a. Corticosteroid use
 - b. Thiazide diuretics
 - c. Beta blockers.
2. Type-2b hyperlipoproteinaemia is seen with
 - a. Alcohol abuse
 - b. Oral contraceptives.

C. Renal

1. Type-2a or 2b hyperlipoproteinaemia is seen in nephrotic syndrome
2. Type-4 hyperlipoproteinaemia is seen in uraemia.

D. Hepatic

1. Type-2a or 2b hyperlipoproteinaemia is seen in hepatomas

NCEP Guidelines (National Cholesterol Education Programme)

<i>LDL cholesterol (mg%)</i>	
<100	Optimal
100-129	Near optimal/above optimal
130-159	Border line high
160-189	High
> 190	Very high
<i>Total cholesterol (mg%)</i>	
< 200	Desirable
200-239	Borderline high
> 240	High
<i>HDL (mg%)</i>	
< 40	Low
> 60	Borderline high
<i>Triglycerides (mg%)</i>	
<150	Normal
150-199	Borderline high
200-499	High
> 500	Very high

2. Type-4 hyperlipoproteinaemia is seen in acute hepatitis.

Risk categories modify LDL-C goals:

High risk categories are those with CAD and CAD risk equivalents. CAD risk equivalents include clinical CAD, carotid artery disease, peripheral vascular disease and abdominal aortic aneurysm. Other CAD equivalents include DM, HTN, smoking and metabolic syndrome (abdominal obesity, HTN, DM, low HDL-C and elevated TGL) In these patients the LDL-C must be lowered < 70 mg/dL by aggressive therapy.

E. Immunologic

1. Type-1 hyperlipoproteinaemia is seen in SLE
2. Type-3 hyperlipoproteinaemia is seen in multiple myeloma.

Bile Acid Sequestrants

Cholestyramine
Colestipol.

Diet Therapy of High Blood Cholesterol

<i>Nutrient</i>	<i>Recommended intake</i>	
	<i>Step I Diet</i>	<i>Step II Diet</i>
Total fat	30% of total calories	20% of total calories
Saturated fatty acids	10% of total calories	7% of total calories
Polyunsaturated fatty acids	10% of total calories	7% of total calories
Monounsaturated fatty acids	10% of total calories	7% of total calories
Carbohydrates	55% of total calories	55% of total calories
Protein	15% of total calories	15% of total calories
Cholesterol	300 mg/dl	< 200 mg/dl



Mechanism of Action

1. Both act by binding bile acids in the intestinal lumen
2. Receptor mediated removal of LDL from plasma.

Dose

Cholestyramine 24 g/day
 Colestipol 30 g/day.

Side Effects

Constipation and bloating
 Exacerbation of pre-existing haemorrhoids.

Drug Interaction

Decreases the absorption of digitalis, β blockers, thyroxine, thiazides and warfarin.

Nicotinic Acid

Mechanism of Action

1. Reduces lipolysis in adipose tissue
2. Direct inhibition of the synthesis and secretion of apo B-containing particles by the liver.
3. Reduction in synthesis of lipoproteins.

Dose

3–6 g/day.

Indications

1. Heterozygous familial hypercholesterolaemia
2. Familial combined hyperlipidaemia.

Side Effects

Cutaneous flushing
 Nausea, abdominal discomfort
 Dryness of the skin
 Blurred vision.

Flushing can be prevented by concurrent intake of small dose of aspirin or NSAID.

Laboratory Abnormalities

Hyperglycaemia
 Hyperuricaemia
 Increased plasma amino transferase
 Increased plasma alkaline phosphatase.

Contraindications

Gouty arthritis
 Active liver disease
 Peptic ulcer.

HMG CoA Reductase Inhibitors

The specific competitive inhibitors of the rate-limiting enzymes in cholesterol synthesis are lovastatin, pravastatin, simvastatin, ganavastatin, cerivastatin, fluvastatin and atorvastatin.

Mechanism of Action

1. Reduction of rate of hepatic cholesterol synthesis
2. Reduction in the cellular pool of cholesterol
3. Compensatory increase in affinity for LDL receptors.

Effects

Decreases LDL concentration in patients with heterozygous familial hypercholesterolaemia and familial combined hyperlipidaemia.

Dose

Lovastatin 10 to 80 mg/day
 Simvastatin 10 to 40 mg/day
 Pravastatin 10 to 40 mg/day
 Atorvastatin 10-80 mg/day
 Fluvastatin 20-40 mg/day
 Cerivastatin 0.3-0.4 mg/day
 Rosuvastatin 5-20 mg/day

Benefits with statin therapy:

- Prevents as well as arrests the process of atherosclerosis
- Stabilises the unstable atherosclerotic plaque
- Improves endothelial function
- Exhibits anti-thrombotic and anti-inflammatory effects
- Reduces CHD events such as angina, myocardial infarction
- Reduces the risk of cerebrovascular events such as stroke
- Reduces the need for angioplasty/bypass surgery
- Reduces risk of restenosis in patients who have undergone angioplasty or bypass surgery
- Reduces the number of hospitalisations/duration of hospital stay

Side Effects

Nausea, fatigue, insomnia, myalgias, headaches, changes in bowel function, skin rashes and myopathy.

Ezetimibe

It is a cholesterol absorption inhibitor at the level of the enterocyte. The dose is 10 mg OD and the absorption is not affected by food. It lowers LDL level. It can be given

LDL Cholesterol Goals and Cutpoints for Therapeutics Lifestyles Changes (TLC) and Drug Therapy in Different Risk Categories

Risk category	LDL Goal	LDL level at which to initiate therapeutic lifestyle changes (TLC)	LDL level at which to consider drug therapy
CHD or CHD risk equivalents (10-year risk > 20%)	< 100 mg/dL	>100 mg dL	> 130 mg/dL (100-129 mg/DL-drug optional)* 10-year risk 10-20%: > 130 mg/dL
2 + Risk factors (10-year risk < 20%)	< 130 mg/dL	> 130 mg/dL	10-year risk < 10%: > 160 mg/dL
0-1 risk factors	< 160 mg/DL	> 160 mg/dL	> 190 mg/dL (160-189 mg/dL: LDL-lowering drug optional)

CHD risk equivalent means diabetes mellitus or peripheral vascular disease or carotid stenosis or multiple risk factors

Drug Therapy of Primary Hypercholesterolaemia

Lipoprotein abnormality	Plasmalipoprotein elevated	Drug Therapy	
		First line	Second line
Primary Hypercholesterolaemia	LDL	Cholestyramine Colestipol Nicotinic acid Lovastatin Pravastatin Simvastatin (Fenofibrate Ciprofibrate combined drug therapy) Atorvastatin	Probucol Gemfibrozil Acipimox
Combined Hyperlipoproteinaemia	LDL +VLDL	Nicotinic acid Lovastatin Pravastatin Simvastatin Ganvastatin Gemfibrozil Combined drug therapy Atorvastatin	Cholestyramine Colestipol Clofibrate Acipimox
Type III Hyperlipidaemia	Chylomicrons and VLDL	Clofibrate Gemfibrozil Lovastatin Pravastatin Simvastatin Nicotinic acid Atorvastatin	
Severe Hypertriglyceridaemia	Chylomicrons and VLDL	Gemfibrozil Nicotinic acid Fenofibrate	Clofibrate

alone or in combination with statins. The action of statin is potentiated. It can cause diarrhoea.

Fibrates

Clofibrates
Gemfibrozil.

Mechanism of Action

1. Activation of lipoprotein lipase, suppression of free fatty acid release from adipose tissue.
2. Inhibition of hepatic triglyceride synthesis
3. Secretion of cholesterol into bile.
4. Inhibition of biosynthesis of cholesterol.

Dose

Clofibrate	2 g/day
Gemfibrozil	1.2 g/day
Fenofibrate	200 mg/day

Indication

Heterozygous familial hypercholesterolaemia.
Hypertriglyceridaemia

Side Effects

GIT side effect, headache, insomnia, rash, urticaria and pruritus.

Osteomalacia

It is the failure of bone matrix (osteoid) to get mineralised normally. When it occurs in children, it is called rickets and when it occurs after epiphyseal closure, it is referred to as osteomalacia.

Aetiology**1. Vitamin D Deficiency**

- a. Dietary deficiency
- b. Lack of synthesis in skin
- c. Decreased absorption
 - (i) Coeliac disease
 - (ii) Hepatobiliary disorders
 - (iii) Pancreatic disease
 - (iv) Gastric and intestinal surgery.

2. Defective Metabolism

- a. Drugs (anticonvulsants, sedatives, rifampicin)
- b. Chronic renal failure
- c. Renal osteodystrophy
- d. Dialysis bone disease
- e. Vitamin D dependent rickets.

3. Hypophosphataemia with Normal Vitamin D

- a. Familial hypophosphataemic rickets
- b. Inherited and acquired renal tubular defects (e.g. Fanconi syndrome, cadmium poisoning, multiple myelomatosis).

4. Osteomalacia with Normal Calcium, Phosphate and Vit D

- a. Hypophosphatasia
- b. Osteogenesis imperfecta
- c. Aluminium bone disease.

**Clinical Features**

1. Severe bony pain and tenderness on pressure
2. Muscular weakness (waddling gait)
3. Spontaneous fracture of neck of femur
4. Features of tetany (carpopedal spasm and facial twitching).

**Investigations**

1. The serum calcium and phosphate are low
2. Alkaline phosphatase level is raised
3. There is loss of cortical bone
4. The apparent partial fracture without displacement (pseudofracture or looser zones) is seen in lateral border of the scapula, inferior femoral neck, the pubic rami and the medial cortex of the upper femur. (X-ray shoulder girdle for scapula, pelvic girdle for pubic rami and neck of femur and chest X-ray for ribs) (Fig. 9.46).
5. The microfracture, expansion of intervertebral disc leading to biconcave (codfish) vertebra.



Fig. 9.46: Osteomalacia

**Treatment**

1. *Dietary vitamin D deficiency*: Vitamin D 50,000 IU PO weekly for several weeks to replace bone stores, followed by long-term therapy with 400 to 1000 IU/day.

2. *Malabsorption of vitamin D*: Vitamin D 50,000 IU PO per day to 50,000 IU PO per week
3. Calcium supplementation
4. If it is due to malabsorption, give parenteral calciferol 7.5 mg monthly.
5. If it is vitamin D resistant, give calciferol 10,000 units/24 hr PO.
6. If it is due to renal disease, give alphacalcidol 1 mg/24 hr PO and adjust the dose according to the plasma calcium.

Osteoporosis

It refers to reduction of bone mass per unit volume (loss of matrix and defective mineralisation) (Fig. 9.47).

Aetiology

- | | |
|----------------------|---|
| 1. Involutional | Type I (postmenopausal) and Type II (senile) |
| 2. Endocrinological | Hyperthyroidism
Hyperparathyroidism
Diabetes mellitus
Hypogonadism
Cushing's syndrome |
| 3. Gastrointestinal | Malnutrition
Malabsorption
Anorexia nervosa |
| 4. Haematological | Multiple myeloma
Mastocytosis |
| 5. Rheumatological | Rheumatoid arthritis |
| 6. Collagen vascular | Marfan's syndrome
Ehler-Danlos syndrome
Osteogenesis imperfecta |

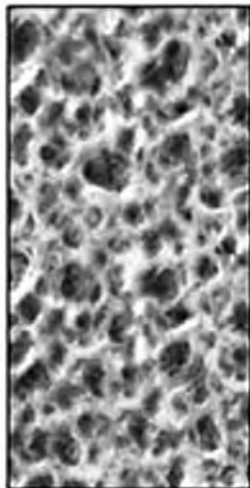

Normal bone

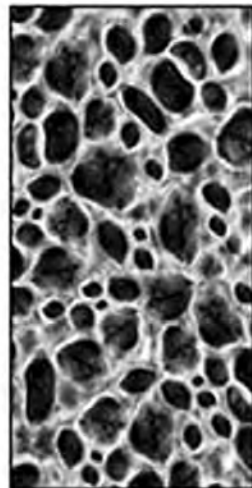

Osteoporosis

Fig. 9.47

7. Drugs
 - Anticonvulsants
 - Steroids
 - Vitamin A
 - Alcohol
 - Heparin
 - Furosemide
 - Thyroid hormone in excessive doses
 - Lithium
 - GnRH agonist
 - Cyclosporin
 - Cytotoxic drugs
8. Cigarette smoking
9. Glucocorticoid therapy
10. Hypogonadism
11. Alcoholism
12. Renal disease
13. GI/Hepatic disorders

Types

Features	Type-I	Type-II (senile)
Age	50–70 years	> 70 years
Sex F : M	6 : 1	2 : 1
Bone	Trabecular	Trabecular and cortical
Fractures	Forearm, crush vertebra	Hip, wedge vertebra



Clinical Features

1. The clinical features depend upon the major clinical sequelae (fracture of the vertebra, wrist, hip, humerus and tibia).
2. Pain is usually of acute onset in the dorsal and lumbar regions and often radiating to flanks and abdomen. Pain is often aggravated by bending, lifting weights or while jumping.
3. Loss of appetite and muscular weakness are also present.
4. The collapse fractures of vertebral bodies (anterior) usually produce wedge shaped deformity with loss in height and results in dorsal kyphosis and exaggerated, cervical lordosis (dowager or widows hump).
5. Scoliosis is also common.

WHO Criteria for Osteoporosis

Diagnosis	T Score
Normal	> 1.0 SD
Osteopenia	1.0 to 2.5 SD
Osteoporosis	< 2.5 SD
Severe osteoporosis	< 2.5 SD with fragility fractures



Fig. 9.48: Osteoporosis-spine "COD FISH VERTEBRA"



Investigations

1. *Radiological*
X-ray thoracolumbar region, radius and neck of femur
 - a. Decrease in mineral density in bone.
 - b. Fracture (mostly seen in middle, lower thoracic and upper lumbar vertebral bodies). Upper dorsal spine fracture (above D₄) suggests malignancy rather than osteoporosis.
 - c. Collapse
2. *Biochemical*
 - a. Serum calcium or phosphate and alkaline phosphatase are normal (increase in alkaline phosphatase after fracture).
 - b. Urine hydroxy proline (24 hour) is relatively high in a case associated with the endocrinopathy.
3. *Measurement of bone mass:*
The techniques available include:
 - a. Dual energy X-ray absorptiometry (DXA)
 - b. Single energy X-ray absorptiometry
 - c. Quantitative CT
 - d. USG

Indications for measurement of bone mass:

- Oestrogen deficient women at clinical risk of osteoporosis
- Vertebral anomalies on X-ray suggestive of osteoporosis
- Glucocorticoid treatment equal to >7.5 mg prednisolone or duration of therapy more than 3 months.

- Primary hyperparathyroidism.
- Monitoring response to therapy for osteoporosis.



Differential Diagnosis

1. Hyperparathyroidism
2. Osteomalacia
3. Lymphoma
4. Leukaemia
5. Metastatic carcinoma
6. Multiple myeloma.



Treatment

- A. *General*
 1. Bedrest
 2. Local heat
 3. Analgesics
 4. Exercise: Regular walking or other weight bearing exercise for 1 hour 3 times a week protects bone mass
 5. Prevention of injury (most hip and wrist fractures are caused by falls).
 6. Excessive thyroid hormone replacement therapy should be avoided.
- B. *Antiresorptive agents*
 1. Oestrogen: Oestrogen 0.625 mg + Medroxyprogesterone (cyclic progestin) 5–10 mg per day 10–14 days/month. Progesterone to be added to prevent endometrial carcinoma.
Transdermal oestrogen patches are used to avoid deep vein thrombosis and pulmonary embolism.
Oestrogen therapy is important in women with premature or surgical menopause. Contraindications of oestrogen therapy are carcinoma breast or endometrial cancer, recurrent thromboembolic disease, acute liver disease and unexplained vaginal bleeding.
 2. Calcium: The recommended daily calcium intake for postmenopausal women is 1,500 mg, and 1,000 mg for premenopausal women.
 3. Calcitonin: Salmon calcitonin for 1–2 years increases vertebral bone density and decreases the risk of vertebral fracture. The usual dose is 50 IU SC per day 3 times a week. (salmon calcitonin 200 units/day as nasal spray).
The side effects are nausea, flushing, and rarely allergic reactions.

4. Bisphosphonates: They specifically impair osteoclast function and reduce osteoclast number partly by induction of apoptosis.
 - a. Alendronate 5-10 mg/day
 - b. Risedronate 5 mg/day
The prominent adverse effect is esophageal irritation and hence both should be taken with a full glass of water and the patient should remain upright for 30 min after taking the drug.
 - c. Etidronate is given as an intermittent cyclical regimen, 400 mg orally for 2 weeks, has some efficacy against vertebral fractures.
5. Selective oestrogen receptor modulators (SERMS)
 - a. Raloxifene 60 mg/day
 - b. Tamoxifen
Both reduce bone turnover and bone loss in postmenopausal women. In addition Tamoxifen is beneficial in women at increased risk of breast cancer and Raloxifene reduces serum total and LDL cholesterol, Lp (a), and fibrinogen.

C. Bone forming agents

- a. Fluoride—75 mg/day
- b. Anabolic steroids: Testosterone is used in the treatment of osteoporotic man with gonadal deficiency.

D. Supplementation of Vitamin D metabolites and thiazide diuretics.

Male Osteoporosis

The incidence of osteoporosis in men is increasing due to the increased longevity of the population. The late onset of osteoporosis in men (10 years behind that of women) is due to higher initial bone mass in early life and absence of sudden loss of gonadal hormones as occurs in menopause in women.



Management

- a. Good calcium and vitamin D intake
- b. Regular physical exercise
- c. Avoid smoking and excessive alcohol
- d. Testosterone replacement for hypogonadism
- e. Bisphosphonates like alendronate has been shown to increase bone mass and reduce incidence of fractures.
- f. Management of concurrent medical disorders.

Paget's Disease

- Focal skeletal disorder – rapid disorganized bone remodeling affecting one or more bones – Characterised by increased bone turn over (osteoclastic activity) and increased but disorganized osteoid formation (osteoblastic activity)
- Incidence – 3% of population older than 50 years
- Family history – 15-30%
- Often affects pelvis, femur, spine and skull
- Bone pain, deformity and degenerative arthritis
- Sometimes extensive multifocal involvement of many bones can occur
- Enormously elevated serum alkaline phosphatase value as a result of increased bone turn over.



Clinical Features

- Bone pain due to micro-fractures
- Muscular strain and accelerated osteoarthritis
- Joint deformity due to periarticular bone involvement
- Enlargement of head – due to involvement of skull
- Reduction in height
- Narrowing of cranial ostia and compression of cranial nerves
- Nerve root compression due to vertebral involvement
- Otosclerosis – hearing loss
- Hypercalcaemia and hypercalciuria with nephrolithiasis – due to prolonged immobilisation
- High output cardiac failure – increased blood flow to the affected bones
- Osteogenic sarcoma – late complication and sudden accentuation of bone pain at a specific site denotes the possibility



Investigations

- Elevated serum alkaline phosphatase
- Increased ^{99m}Tc bone scanning activity
- Characteristic X- ray finding – local radiolucency – more commonly affecting one region of skull 'Osteoporosis Circumscripta'
- X-ray tibia of lower limb (Fig. 9.49).

Indications for Therapy

1. Bone pain due to paget's disease.
2. Nerve compression syndromes
3. Pathologic fracture



Fig. 9.49: Paget's disease—tibia

4. Progressive skeletal deformity
5. Immobilisation hypercalcaemia
6. Asymptomatic involvement of weight-bearing bones and skull.



Management

1. Adequate hydration and mobilisation to avoid hypercalcaemia
2. Pain relief – ibuprofen, COX-2 inhibitors
3. Mild disease (serum alkaline phosphatase < 3 times)
Tiludronate 400 mg/day for 3 months or
Etidronate 400 mg/day for 6 months
4. Moderate to severe disease
Risedronate 30 mg/day for 2-3 months
Alendronate 40 mg/day for 6 months

The effectiveness of therapy is monitored by measurement of serum alkaline phosphatase (SAP) and it must be monitored every 3 months. Therapy can be repeated when the SAP level increases above normal by 25%.

In very severe disease Pamidronate single dose 60 mg IV in 500 ml normal saline or dextrose over 4 hours for rapid response. Repeat the course weekly once for 1 month if the response is not adequate.

Calcitonin: Reserved for patients who cannot tolerate bisphosphonates.

Injection salmon calcitonin 100 U/day SC followed by 50 U SC three times/week for maintenance. It causes suppression of SAP. Use nasal form for milder disease.



Chapter 10

Connective Tissue Disorders

SYMPTOMS

JOINTS

PAIN

SWELLING
(acute/chronic
mono/polyarticular
symmetrical/asymmetrical)

MORNING STIFFNESS

LOSS OF FUNCTION

WEAKNESS

DEFORMITY

INSTABILITY

CHANGES IN SENSATION

SYSTEMIC SYMPTOMS

FEVER
RASH

FATIGUE
WEIGHT LOSS

HAIR LOSS

MUCOSAL ULCERS
(oral/genital)

DIARRHOEA

URETHRITIS

COLDNESS OF FINGER

DRY EYES/MOUTH
RED EYES

SIGNS

SYSTEMIC EXAMINATION

Inspect,

Rash
(malar area, over eyelids
generalised, over back
hair, scalp, axilla, gluteal
cleft, under the breast)

Photosensitivity
Microstomia
Ulcers
(mucosa-ocular/oral/genital
fingertips)
Iritis/Scleritis
Nodes/Nodules
Sclerodactyly
Raynaud's phenomenon
Pallor
Nail/hair changes

Hepatosplenomegaly
Prox. muscle weakness
Mononeuritis
Fundus changes

JOINT EXAMINATION (including spine ex.)

Inflammatory signs in
joint

Pattern of joint
involvement

Muscle wasting
Attitude of limbs
deformity
Range of movements
Crepitus
Stress tests

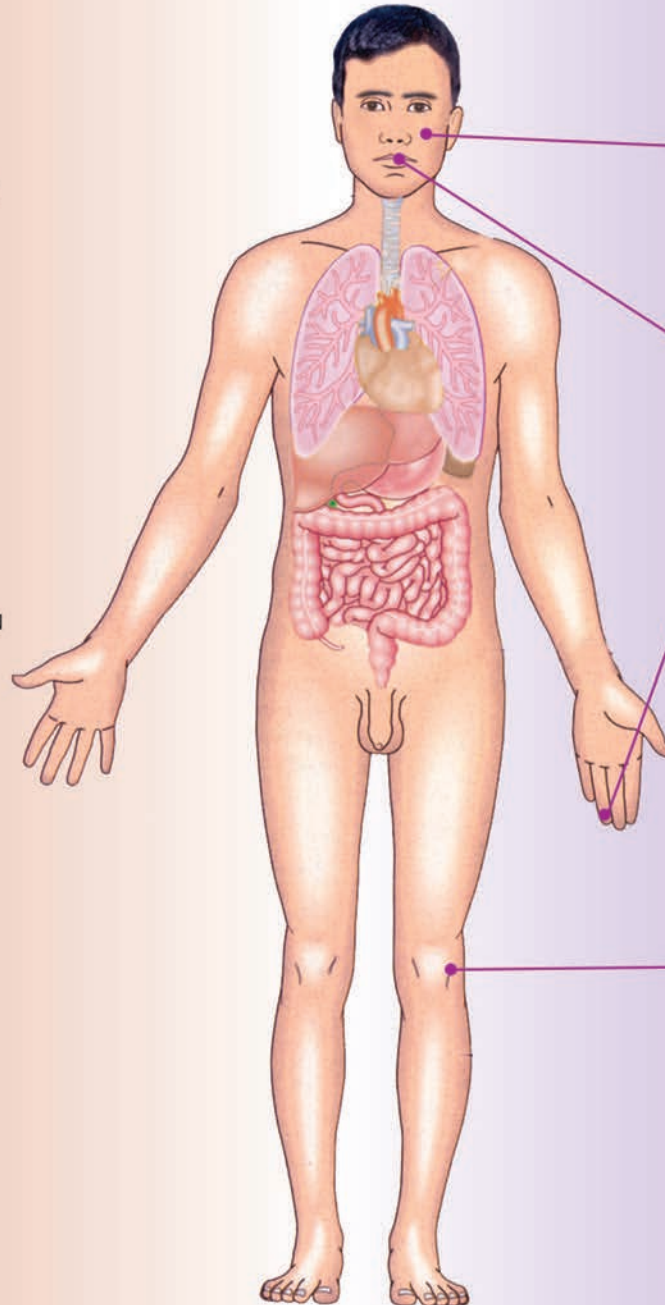



Arthritis

Classification

A. Monoarthritis

Acute	Septic arthritis Gout Pseudogout Traumatic arthritis
Chronic	Psoriasis Ankylosing spondylitis Rheumatoid arthritis Tuberculosis Sarcoidosis Osteoarthritis

B. Polyarthritis

Asymmetric	
Acute	Rheumatic fever Reactive arthritis
Chronic	Psoriatic arthritis
Symmetric	
Acute	Hepatitis B, serum sickness
Chronic	Rheumatoid arthritis Systemic lupus erythematosus Osteoarthritis

C. Axial Arthritis

Ankylosing spondylitis
Reiter's syndrome
Tuberculosis
Brucellosis
Cervical or lumbar spondylosis.

Rheumatoid Arthritis

It is a chronic inflammatory, destructive and deforming symmetrical polyarthritis associated with systemic involvement. The individuals with HLA-D4 and HLA-DR4 are more prone to rheumatoid arthritis. The female: male ratio is 3 : 1.

Criteria for the Diagnosis

- Morning stiffness (more than one hour for more than six weeks)
- Arthritis involving three or more joint areas (with or without soft tissue involvement lasting more than six weeks)
- Arthritis of hand joints (wrist, MCP or PIP joints more than six weeks)

- Symmetrical arthritis (at least one area lasting for six weeks)
- Rheumatoid nodules
- Rheumatoid factor
- Radiographic changes.

Diagnosis of rheumatoid arthritis is made when four or more criteria are present.

Pathogenesis

- Synovitis (synovial cell hyperplasia, hypertrophy with CD4 lymphocytic infiltration and synovial effusion)
- Pannus formation
- Cartilage loss
- Fibrosis
- Bony erosion, deformity, fibrous and bony ankylosis
- Muscle wasting
- Periarticular osteoporosis.

Triggering Factors

- Infection
- Vaccinations
- Physical trauma
- Psychological stress.



Clinical Features

- Fatigue
- Weakness
- Vague arthralgias
- Myalgias
- Joint stiffness
- Low grade fever
- Weight loss
- Excessive sweating
- Lymphadenopathy.

The other joint manifestations are swelling, warmth, tenderness, and synovial thickening without erythema.

The joints most commonly involved are:

- Finger joint (40%)
- Shoulder joint (20%)
- Foot joint (20%)
- Wrist joint (15%).

Other joints involved in chronic rheumatoid arthritis are:

- Temporomandibular joint (malalignment of teeth with mal occlusion)
- Cervical joints C₁ C₂ (atlanto axial dislocation—quadriplegia)



3. Crico-arytenoid (sensation of foreign body, hoarseness, weak voice and stridor)
4. Sternoclavicular
5. Acromioclavicular
6. Glenohumeral
7. Elbow (extension defects, epicondylitis and olecranon bursitis-ulnar deviation), hand (swan neck deformity, button-hole deformity)
8. Hip and knee (Morant-Baker's cyst)
9. Talocalcaneal, midtarsal, metatarsophalangeal.

Course

It is variable.

It can be slowly progressive with oligoarthritis or rapidly progressive erosive arthritis with marked deformity with downhill course.

The following features, exclude rheumatoid arthritis

1. Butterfly rash—SLE
2. High concentration of LE cells
3. Polyarteritis nodosa
4. Dermatomyositis
5. Scleroderma
6. Chorea
7. Erythema marginatum
8. Arthritis associated with bacterial or viral infections
9. Positive AFB
10. Reiter's syndrome
11. Shoulder hand syndrome
12. Hypertrophic pulmonary osteoarthropathy
13. Neuroarthropathy
14. Homogentisic acid in urine
15. Sarcoidosis
16. Multiple myeloma
17. Erythema nodosum
18. Leukaemia and lymphoma
19. Agammaglobulinaemia
20. Distal interphalangeal joint of hand and feet (Fig. 10.1).

Nonarticular Manifestations of Rheumatoid Arthritis (Fig. 10.2)

Respiratory System

1. Pleurisy with or without effusion
2. Pneumothorax
3. Rheumatoid nodule (Caplan's)
4. Interstitial fibrosis
5. Pneumonia
6. Chronic bronchitis or bronchiectasis
7. Pulmonary hypertension.



Fig. 10.1: Rheumatoid arthritis—sparing of distal IP joints

Cardiovascular System

1. Pericarditis
2. Endocarditis
3. Cardiomyopathy
4. Conduction defects
5. Cardiac arrhythmias
6. Infiltration of valves (mitral incompetence and aortic incompetence)
7. Myocardial infarction (due to coronary vasculitis).

Gastrointestinal System

1. Xerostomia
2. Parotid enlargement
3. Dysphagia
4. Mesenteric artery occlusion.

Renal System

1. Pyelonephritis
2. Analgesic nephropathy
3. Amyloidosis.

Lymph Nodes

Local and generalised lymphadenopathy.

Ocular

1. Episcleritis, scleritis (Fig. 10.3)
2. Keratoconjunctivitis sicca
3. Scleromalacia perforans.

Ear

Defective hearing (involvement of ossicular chain).

Muscle

- 1 Weakness and atrophy

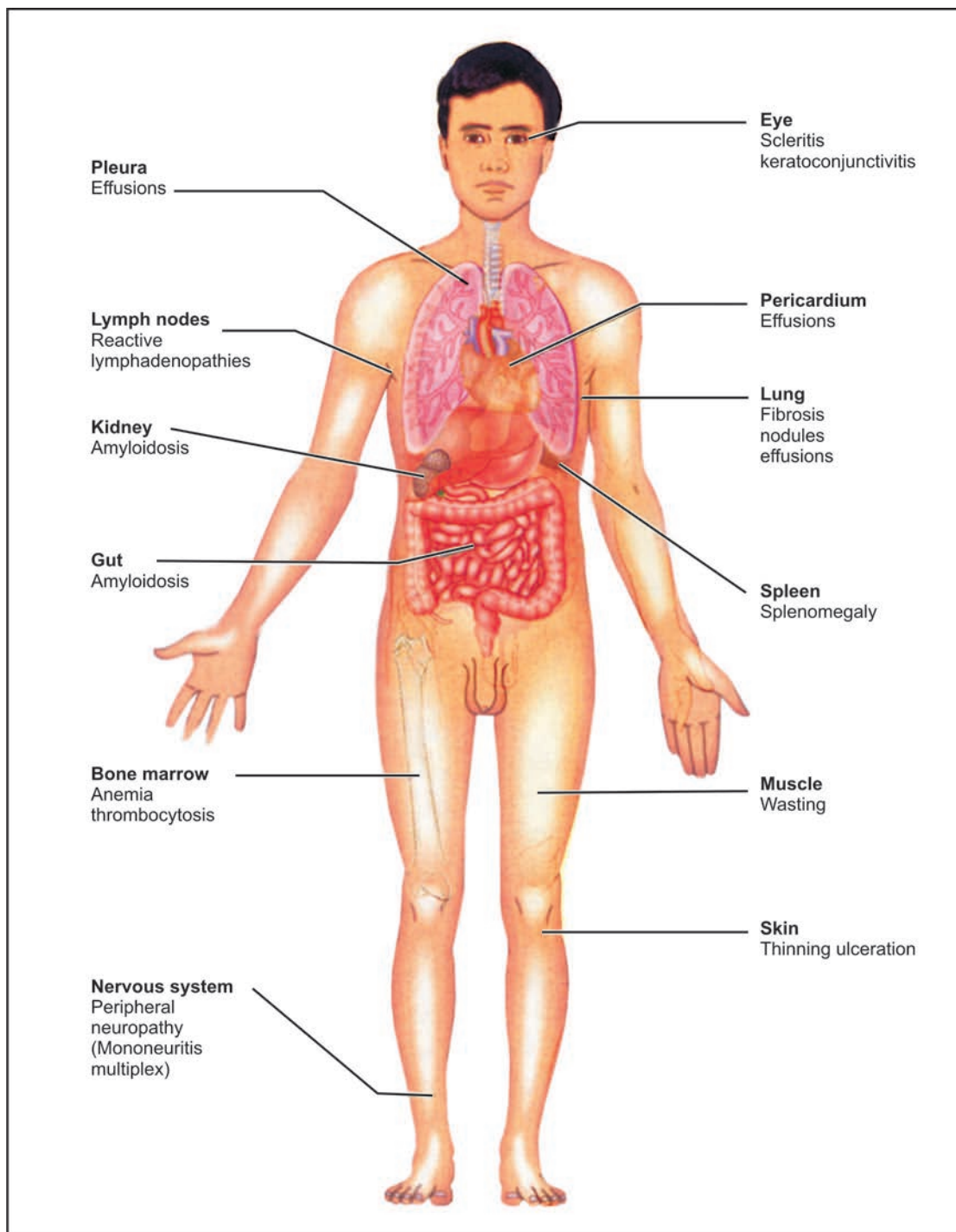

Fig. 10.2: Extra-articular manifestations—rheumatoid arthritis



Fig. 10.3: Rheumatoid arthritis-scleritis

2. Myopathy (steroid, chloroquine)
3. Tenosynovitis.

Skin

1. Dermal atrophy
2. Leg ulcers
3. Nail dystrophy
4. Nodules
5. Pyoderma gangrenosum.

Bones

Periarticular osteoporosis

Central Nervous System

1. Cervical dislocation (quadriplegia)
2. Peripheral neuropathy (sensory and motor)
3. Autonomic neuropathy (reduced sweating, cold hands, and palmar erythema)
4. Entrapment neuropathy.
 - a. Elbow-ulnar
 - b. Carpal tunnel—median
 - c. Knee—lateral popliteal
 - d. Tarsal tunnel—posterior tibial.

Haematological

1. Anaemia
 - a. normocytic hypochromic
 - b. megaloblastic (↓ folic acid)
2. Haemolytic anaemia
3. Serum Fe—low
4. Iron binding capacity—normal
5. Raised ESR
6. Neutropenia
- Pancytopenia Felty's syndrome
- Splenomegaly

7. Eosinophilia (vasculitis, nodules)
8. Hyperviscosity syndrome
It is due to increased rheumatoid factor. The manifestations are dizziness, diplopia, dyspnoea and bleeding tendency.
9. Vasculitis
 - a. Dermal infarction
 - b. Cranial-cerebrovascular accidents
 - c. Coronary-myocardial infarction
 - d. Mesenteric-gut gangrene
 - e. Peripheral-digital gangrene
 - f. Vasa nervosum-neuropathy.

Variants of Rheumatoid Arthritis

1. *Felty's syndrome*: It is characterised by splenomegaly, neutropenia, pancytopenia and lymphadenopathy
2. *Still's disease (rheumatoid arthritis occurring in children)*: It is characterised by mono or polyarthritis, fever, maculopapular rash, hepatosplenomegaly, lymphadenopathy, and leucocytosis. The rheumatoid factor and antinuclear antibody are negative. It mostly occurs in juvenile age group. The joint deformity is rare but growth retardation is present.
3. *Sjögren's syndrome*: It is characterised by enlargement of lacrimal and salivary glands, xerostomia, keratoconjunctivitis sicca, leucopenia, lymphocytosis, and eosinophilia. The rheumatoid factor is positive and there is eosinophilia.

Comparison of Rheumatoid Arthritis and Osteoarthritis

Characteristics	Rheumatoid arthritis	Osteoarthritis
Age	Any age group	Middle/old age
Inflammation	Prominent	Mild
Disease cause	Autoimmunity	Trauma
Onset	Rapid with swelling	Gradual
Bone density	Decreased(osteoporosis)	Increased
Stiffness	Morning stiffness	Due to joint damage
Synovial space	Thickened and increased	Decreased
DIP - Joint	Never involved	Involved



Investigations

1. Complete blood count (anaemia, thrombocytosis, ↑ ESR)
2. Increased acute phase proteins (C-reactive protein)
3. Increased plasma viscosity
4. Serum proteins
 - a. Albumin ↓



Synovial Fluid

	Colour	Viscosity	Clarity	Cell Count/mm ³	Other Tests
Normal	Colourless	Very high	Clear	0–200	
Osteoarthritis	Colourless	High	Clear	400–4000	
Rheumatoid arthritis*	Yellow	Low	Cloudy	4000–40000	Low complement
Seronegative inflammatory arthritis	Yellow	Low	Cloudy	4000–40000	Normal complement
Gout/Pseudo-gout	Variable	Low	Variable	2000–40000	Crystals—monosodium urate, calcium pyrophosphate dihydrate under polarising microscope
Septic arthritis	Yellow	Low	Very turbid	> 50000	Gram stain, culture and GLC (gas liquid chromatography)

* Poor mucin precipitation

b. Gammaglobulins ↑

c. α_2 globulin ↑

d. IgG, IgM, IgA ↑

5. Serological tests

Rheumatoid factor: Rheumatoid factors are immunoglobulins of the IgG or IgM class which react with the Fc portion of IgG. It is produced by plasma cells and lymphocytes in subsynovial tissue and draining lymph nodes. It is detected by

a. **Rose Waaler test:** It is more specific and is said to be positive when more than 1 : 32

b. **Latex test:** It is sensitive, but less specific and said to be positive when more than 1 : 20. The above two tests are used to detect IgM rheumatoid factor.

6. Radiological features of rheumatoid arthritis

- Early: soft tissue swelling
periarticular osteoporosis
periosteitis
erosions—periarticular and subarticular cysts
- Late: narrowed joint spaces
articular surface irregularity
osteoporosis
subluxation
ankylosis
secondary osteoarthritis

7. Antinuclear antibody is positive in 20 to 50%.

8. LE cell is positive in 10 to 20%.

9. Pleural fluid analysis

- Low glucose
- Increased LDH
- Low complement

10. Synovial fluid analysis

11. Antibodies to CCP (Cyclic citrullinated polypeptide). This test has similar sensitivity and better specificity for RA than RF. Presence of anti-CCP

is most common in person with aggressive disease with a tendency for developing bone erosion.



Management

A. Goals

- Education and motivation.
- Disease modification through the suppression of inflammation and the immunologic process which is active systemically and in the joints and other tissues.
- Maintenance of joint function and prevention of deformities.
- Repair of joint damage if it will relieve pain or facilitate function.

B. Systemic and Articular Rest

- Short bed-rest is recommended for about an hour in the midmorning and midafternoon.
- Splints: The wrist splints are particularly useful during bouts of acute wrist synovitis and for management of carpal tunnel syndrome.

C. Physiotherapy

- Regular Exercise**
 - Exercise is most successful after heat application.
 - A fifteen minute early morning shower or a bath at 98–100 °F will help decrease morning stiffness.
 - Static quadriceps exercises should be performed to strengthen the muscular, ligamentous, and tendinous support of the knees.

2. Joint Protection

The principles of joint protection are maintenance of muscle strength and range of motion, avoidance of positions of deformity, the use of the strongest joints possible for a given task, and the utilization of joints in the most stable anatomic planes.

D. Drug therapy



Group I: Nonsteroidal Anti-inflammatory Drugs (NSAIDs)

- a. Aspirin
- b. Indomethacin
- c. Fenamides
- d. Propionic acid compounds
- e. Sulindac (clinoryl)
- f. Tolmetin
- g. Piroxicam
- h. Diclofenac
- i. COX2 inhibitors

Choice of NSAIDs

The general approach is to choose an NSAID and treat for 2–4 weeks, the usual time period needed to define the drug's efficacy and side effect profile.

Salicylates

Aspirin (acetylsalicylic acid): Aspirin is the initial treatment of choice of rheumatoid arthritis.

Dose: 3–4 grams per day

Preparations

1. Plain tablets (inexpensive, cause gastritis, standard tablet dose 325 mg)
2. Buffered tablets (formulated with the insoluble calcium and magnesium antacids)
3. Enteric-coated tablets (the coating remains intact until tablet reaches small intestine)
4. Timed-release tablets (encapsulated aspirin particles, delayed absorption, more sustained plasma levels)
5. Sodium salicylate (enteric-coated) preparations preferred, less potent analgesic than aspirin)
6. Choline salicylate (very soluble, liquid form, negligible gastric bleeding)
7. Choline magnesium trisalicylate (trilisate).

Toxicities

1. *Common*: Dyspepsia, gastrointestinal bleeding, and peptic ulceration.
2. *Tinnitus or deafness*: It is the earliest indication of salicylate toxicity in adults and is reversible with a small (i.e. 1 or 2 tablets) decrease in daily dosage.
3. *Central nervous system symptoms*: Headache, vertigo, nausea, vomiting, irritability, and psychosis (elderly).
4. At high serum levels (25–35 mg/dl), especially in juvenile patients, salicylates may cause mild, acute, reversible hepatocellular injury, as demonstrated by a rise in serum enzymes.

5. Platelet adenosine diphosphate (ADP) release, adhesiveness, and aggregation are inhibited for as long as 72 hours after a single 300 mg dose of aspirin, probably as a result of irreversible acetylation of platelet membrane proteins.

Other Nonsteroidal Anti-inflammatory Drugs (NSAIDs)

These agents are equipotent to aspirin and exert anti-inflammatory action by modifying prostaglandin metabolism.

Indomethacin

Dose: 25–50 mg tid

Drug interactions

Probenecid prolongs action
Furosemide decreases action
Antacids delay absorption

Toxicity

Dyspepsia
GI bleeding
Gastric and ileal ulcer
Drowsiness
Depression
Seizures
Neuropathy
Interstitial nephritis
Hepatitis
Retinopathy
Blood dyscrasias.

Propionic Acid and Other Compounds

1. Ibuprofen (brufen)
2. Ketoprofen
3. Fenoprofen
4. Flurbiprofen
5. Naproxen.

Brufen

Dose: 200–400 mg tid.

- It is less toxic and less effective than aspirin and well tolerated.
- Piroxicam. 10–20 mg dose once daily.

Cyclo-oxygenase – 2 inhibitors

They have selectivity for COX 2 enzyme. GI symptoms and ulcerations are reduced. Platelet function is not impaired. The anti-inflammatory and analgesic efficacy is same as that of traditional NSAIDs.

*Partially selective*

Aceclofenac	100-200 mg /day
Meloxicam	7.5-15 mg/day
Nabumetone	500-1500 mg/day

Highly selective

Celecoxib	100-200 mg BD
Rofecoxib	12.5-50 mg/day

Methotrexate

Methotrexate is the first choice in the management of moderate and severe rheumatoid arthritis. It is non-oncogenic and it acts rapidly in 4-6 weeks and is comparatively less toxic. It can be used along with NSAIDs. It is given in a dose of 7.5 mg PO weekly once along with breakfast. The dose can be increased up to 15 mg once a week.

Folic acid supplementation at a dosage of 1-2 mg daily may reduce methotrexate toxicity without impeding its efficacy.

Toxicities

1. It is teratogenic.
2. Minor side effects – GI intolerance, stomatitis, rash, headache, and alopecia
3. Bone marrow suppression (periodic blood count)
4. Cirrhosis liver (periodic LFT)
5. Hypersensitivity pneumonitis
6. Rheumatoid nodule may develop or worsen (Paradoxical)

Methotrexate can be combined with sulfasalazine 500 mg bid and hydroxychloroquine 200 mg bid in the treatment regimen for RA.

Group II

Disease modifying agents (DMARDs): This group of drugs take a long time (6–12 weeks) for their actions to commence and so in the induction phase, NSAIDs must be given to reduce pain and their dose should be tapered subsequently.

1. Gold
2. Penicillamine
3. Chloroquine
4. Sulphasalazine

Indications

1. Failure of conservative management (even after 3 months with NSAIDs and general measures)
2. Rapidly progressive erosive arthritis.

Indications for 'gold' therapy: It is reserved for patients who continue to have active synovitis or who develop

erosions on a conservative regimen of NSAIDs, rest, and physiotherapy.

Contraindications: It is contraindicated in patients with a history of previous severe skin, bone marrow, or renal reactions to gold.

Dose: Start with 10 mg per wk and then increase up to 50 mg per wk. Maintain with 50 mg once in 2 wks. It can be given orally or intramuscularly.

Toxicities

- a. Bone marrow depression
- b. Renal failure
- c. Stomatitis and oral ulcer
- d. Skin rash
- e. Neuropathy
- f. Hepatotoxicity
- g. Ocular toxicity.

Chloroquine

Indications: Failure to respond to conservative regimen of rest, salicylates, other NSAIDs or gold.

Contraindications: Patients with significant visual, hepatic, or renal impairment or with porphyria, in pregnant women, and in children.

Dose: Chloroquine 250 mg OD;
Hydroxy chloroquine 200 mg BD.

Toxicity

- a. Keratopathy
- b. Retinopathy
- c. Neuropathy
- d. Myopathy.

Penicillamine

It is particularly of value in the therapy of extraarticular manifestations of rheumatoid arthritis (rheumatoid vasculitis, Felty's syndrome).

Dose: 600–1200 mg per day.

Toxicity

1. Taste impairment, anorexia, nausea and dyspepsia
2. Bone marrow aplasia
3. Polyarteritis
4. Nephrotic syndrome
5. Ocular and lingual ulceration
6. Skin rashes
7. Avoid in penicillin allergy.

Sulphasalazine

It is metabolized by the colonic bacteria into 5 amino salicylic acid and sulpha pyridine of which sulpha



pyridine has more important anti-inflammatory role in rheumatoid arthritis.

Dose: Started at 500 mg/day and slowly increased to 1gm BD over a period of 4 weeks.

Toxicity

- a. Rash
- b. Depression
- c. Megaloblastic anaemia
- d. Leukopenia.

Group III (Highly Toxic)

1. Corticosteroids, * ACTH
2. Leflunomide
3. Azathioprine
4. Cyclophosphamide
5. Cyclosporine
6. Levamisole.

*Preferable in children since it does not interfere with growth. The drug of choice is prednisolone.

Corticosteroids

Indications

1. Along with DMARDs in the initial phase, if NSAIDs are not adequate to relieve the distressing symptoms, a short course of 7.5 mg of prednisolone can be added and tapered subsequently.
2. Failure to control the disabling symptoms.
3. Elderly patients in acute conditions.
4. Life-threatening conditions (severe pericarditis, polyarteritis or scleritis).

Dose: Prednisolone 10–15 mg per day.

Toxicities

1. *Endocrine*
 - a. Moon face
 - b. Truncal obesity
 - c. Hirsutism
 - d. Impotence
 - e. Menstrual irregularity
 - f. Suppression of HPA axis
 - g. Growth suppression.
2. *Metabolic*
 - a. Negative Ca, K, N balance
 - b. Sodium and fluid retention
 - c. Hyperglycaemia
 - d. Hyperlipoproteinaemia.
3. *Musculoskeletal*
 - a. Myopathy
 - b. Osteoporosis
 - c. Avascular necrosis.

4. *Skin*

- a. Acne, striae
- b. Skin atrophy
- c. Bruising
- d. Impaired wound healing.

5. *Immunological*

- a. Suppression of delayed hypersensitivity
- b. Reactivation of TB
- c. Susceptibility to infection.

6. *Gastrointestinal*

- a. Peptic ulceration
- b. Pancreatitis.

7. *Cardiovascular*

- a. Hypertension
- b. Congestive cardiac failure.

8. *Ocular*

- a. Glaucoma
- b. Posterior subcapsular cataracts.

9. *CNS*

- a. Changes in mood and personality
- b. Psychosis
- c. Benign intracranial hypertension.

Leflunomide

It inhibits autoimmune T cell proliferation and production of antibodies by T cells. It also blocks TNF dependent nuclear factor kappa B activation.

Dose: 20 mg/day

A loading dose of 100 mg for three days can be used. Clinical response is seen within 4-8 weeks. The drug is teratogenic.

Contraindications: Hypersensitivity, pregnancy, lactation, concurrent vaccination with live vaccines, uncontrolled infection, children < 18 years.

Toxicity: Elevation of liver enzymes, diarrhoea

Azathioprine

It is oncogenic.

It is an antimetabolite with steroid sparing effect and is useful to treat refractory synovitis.

Dose: Initiate with 1.5 mg/kg/day PO in two divided doses and to be increased to 2.5-3 mg/kg/day PO after 8 weeks.

Toxicities

1. Increased incidence of infections
2. Nausea and vomiting
3. Hepatotoxicity (periodic LFT).

Cyclophosphamide

It is effective for the treatment of rheumatoid vasculitis.



Dose: Low- dose PO 1-3 mg/kg/day or high-dose IV bolus 0.5 -1.0 g/m² every 1-3 months. The goal is to obtain a WBC count 4,500 cells/microliter.

Toxicities

1. Increased incidence of infections
2. Haemorrhagic cystitis
3. Nausea and vomiting
4. Gonadal suppression and sterility
5. Alopecia
6. Pulmonary interstitial fibrosis
7. Bladder carcinoma.

Levamisole

It is an immunomodulator and can be given in a dose of 150 mg single weekly dose.

Toxicity

- a. Skin rash
- b. Dyspepsia
- c. Leucopenia
- d. Agranulocytosis (hence the drug is used with caution)

Cyclosporine

It is occasionally used to treat refractory synovitis.

Dose 2-3 mg/kg/day PO and the dose is increased to 5 mg/kg/day.

Toxicities

1. Highly nephrotoxic
2. Hypertension
3. Hirsutism
4. Anaemia
5. Liver dysfunction
6. Oncogenicity.

Group IV (Cytokine Antagonist)

TNF α Antagonist

Anti TNF α drugs produce a very good response when combined with methotrexate.

1. *Infliximab*

It is a chimeric monoclonal antibody that binds with high affinity and specificity to human TNF α .

Dose: 3 mg/kg at 0, 2 and 6 weeks and thereafter at intervals of 4 or 8 weeks intravenously.

Toxicity: nausea, headache, rash, cough, upper respiratory infection, formation of human antichimeric antibodies, antinuclear antibodies and anti-dsDNA antibodies.

2. *Etanercept:*

It is a recombinant fusion protein capable of binding to two TNF α molecules. It has an earlier onset of action than methotrexate.

Dose: 25 mg subcutaneously twice weekly.

Toxicity: Injection site reactions and development of anti-nuclear and anti-dsDNA antibody

3. *Adalimumab:*

It is a fully human monoclonal antibody against TNF α .

Dose: 20-80 mg S/C every 2 weeks

IL 1 Receptor Antagonist

Anakinra

It is a recombinant form of naturally occurring IL-1 receptor antagonist that is approved for use in RA.

Dose 100 mg SC daily.

Toxicities

1. Increased incidence of bacterial infections
2. Injection site reactions
3. Anakinra should not be combined with TNF blocker because of enhanced risk of serious infection and neutropenia.

Plasmapheresis

It is an impractical long-term therapy and its short-term use remains controversial.

A novel approach, pheresis across a column bound with staphylococcal protein A, the **Prosorba** column, has been approved for the treatment of RA.

Medical Synovectomy

Yttrium90 silicate is used for larger joints (knee) and Erbium 159 acetate for smaller joints. Joints should be immobilized for 72 hours to prevent the spread to adjacent lymph nodes. It is contraindicated in patients below 45 years.

Surgical

- a. Synovectomy
- b. Arthroplasty
- c. Osteotomy
- d. Arthrodesis.

Surgical fusion of joints usually results in freedom from pain but also in total loss of motion and this procedure is well tolerated in the wrist and thumb.

Cervical spine fusion of C1 and C2 is indicated for cervical sUBLuxation (> 5 mm) with associated neurological deficits.

Rehabilitations

1. *Physical*
 - a. Bath aid
 - b. Toilet aid
 - c. Dressing aid
 - d. Walking aid



- e. Household aid
 - f. Wheel chair
 - g. Beds
 - h. Reading, writing aids.
2. *Occupational.*



Causes of Death

1. Intercurrent infection
2. Cervical cord lesion
3. Arteritis
4. Cardiac failure
5. Renal failure
6. Amyloidosis
7. Iatrogenic
 - a. Peptic ulcer
 - b. Pyelonephritis
 - c. Steroid toxicity.

Poor Prognostic Factors

1. Increased duration of morning stiffness
2. High titre of rheumatoid factor
3. ↑ ESR
4. Mode of onset (insidious onset of disease)
5. Weak hand grip
6. ↑ed feet-walking time
7. Systemic involvement—active more than one year without remission.
8. Associated vasculitis, rheumatoid nodules
9. Involvement of cervical joints.
10. Protracted anaemia.

Osteoarthritis (OA)

It is a degenerative joint disease. It is characterized by deterioration of articular cartilage with new bone formation – osteophytes at the articular surface. The common joints affected are distal and proximal interphalangeal joints of the hands, first carpometacarpophalangeal joint at the base of thumb, hips, knees, and cervical and lumbar spine. The wrists, elbows, and shoulders are typically spared.

The disease is more common in the elderly but may occur at any age. The precipitating factors may be trauma, congenital malformation, or chronic inflammation. OA of the spine may lead to spinal stenosis with root pain either in the arms or in the lower limbs.

The X-ray of the affected joints reveal narrowing of the joint space, osteophyte formation, and the hands might show Heberdon's and Bouchard's nodes in the distal and proximal interphalangeal joints respectively. CT / MRI are useful to assess the spinal involvement.

Serum biochemistry and complete haemogram are normal.



Management

- Acetaminophen in a dosage of 1,000 mg bid or tid.
- Low dose NSAIDs or COX-2 inhibitors (caution-GI bleeding, heart failure)
- Glucosamine sulphate- 1,500 mg PO daily reduces the symptoms as well as the rate of cartilage deterioration.
- Intra-articular glucocorticoid injection is beneficial (avoid frequent doses)
- Tramadol is an alternative analgesic agent
- Topical capsaicin and NSAID creams for external use.
- Brief periods of rest to the affected joints followed by exercise programs.
- OA-spine – cervical collar, lumbar corset, exercises to strengthen muscles.
- Epidural steroid injection may reduce radicular symptoms.

Seronegative Arthritis

These are a group of diseases in which an inflammatory arthritis, characterised by persistently negative tests for IgM rheumatoid factor is variably associated with a number of other common articular, extra-articular and genetic features.

Ankylosing Spondylitis

- Ankylosing spondylitis (AS) is an inflammatory disorder of unknown cause that primarily affects the axial skeleton.
- The disease usually begins in the second or third decade of life.
- Onset of the disease in adolescence correlates with a worse prognosis and more severe hip involvement.
- Men are affected approximately 3 times more than women. The disease in women tends to progress less frequently to total spinal ankylosis.
- Ankylosing spondylitis shows a striking correlation with the histocompatibility antigen HLA-B27.



Clinical Features

- Sacroiliitis is usually one of the earliest manifestation of AS.



Fig. 10.4: Ankylosing spondylitis-limitation of spinal forward flexion

- The initial symptom is usually a dull pain, insidious in onset, felt deep in the lower lumbar or gluteal region, accompanied by low-back morning stiffness of up to a few hours' duration that improves with activity and returns following prolonged periods of inactivity.
- In some patients, bony tenderness over costosternal junctions, spinous processes, iliac crests, greater trochanters, ischial tuberosities, tibial tubercles, and heels may be present.
- Arthritis in the hips and shoulders may occur.
- Peripheral arthritis, if present, is usually asymmetric.
- Constitutional symptoms such as fatigue, anorexia, fever, weight loss, or night sweats may occur.
- Acute anterior uveitis, can antedate the spondylitis (Fig. 10.5).
- Attacks are typically unilateral and tend to recur.
- Loss of spinal mobility, with limitation of anterior flexion, lateral flexion, and extension of the lumbar spine, is seen (Fig. 10.4).

The Schober Test

It is a useful measure of forward flexion of the lumbar spine. The patient stands erect, with heels together, and marks are made directly over the spine 5 cm below and 10 cm above the lumbosacral junction. The patient then bends forward maximally, and the distance between the two marks is measured. The distance between the two marks increases 5 cm or more in the case of normal

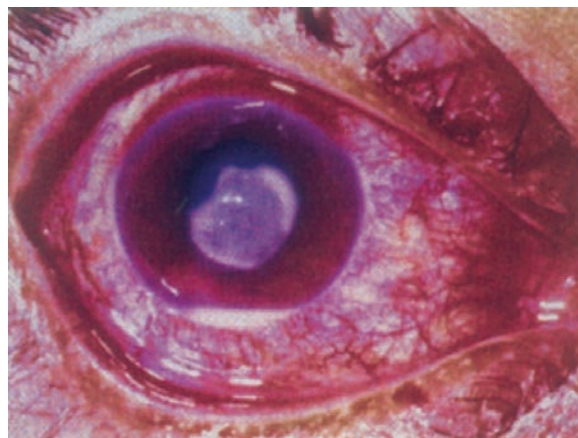

Fig. 10.5: Ankylosing spondylitis-anterior uveitis with hypopyon

lumbar mobility and less than 4 cm in the case of decreased lumbar mobility.

There is limitation of chest expansion (Normal chest expansion is 5 cm or greater).

As the disease progresses, the lumbar lordosis is obliterated with accompanying atrophy of the buttocks. The thoracic kyphosis is accentuated. If the cervical spine is involved, there may be a forward stoop of the neck. Hip involvement with ankylosis may lead to flexion contractures.

The progression of the disease may be followed by

- Measuring the patient's height (the patient's height decreases with progression of the disease due to exaggerated thoracic kyphosis and forward stooping of the neck).
- Chest expansion (chest expansion decreases with disease progression, and produces a restrictive lung disease, culminating in type 1 respiratory failure).
- Schober test.
- Occiput-to-wall distance when the patient stands erect with the heels and back flat against the wall (this distance increases with increasing involvement of the cervical spine by the disease due to increasing forward stoop of the neck).

Complications that can arise are spinal fracture, which can occur with even minor trauma to the rigid, osteoporotic spine. Involvement of the cervical spine can lead to quadriplegia. Cauda equina syndrome is another complication of long-standing spinal disease.

Pulmonary involvement, is characterized by slowly progressive upper lobe fibrosis.

Cardiovascular involvement may manifest as aortic insufficiency or cardiac conduction disturbances (including third degree heart block).

Prostatitis occurs with increased frequency in men.



Investigations

- Elevated ESR and C-reactive protein.
- Mild normochromic, normocytic anaemia.
- Elevated serum alkaline phosphatase.
- Elevated IgA levels.

Radiographic Findings

The earliest changes in the sacroiliac joints demonstrable by plain X-ray show blurring of the cortical margins of the subchondral bone, followed by erosions and sclerosis. Progression of the erosions leads to 'pseudo-widening' of the joint space and later the joints may become obliterated with onset of bony ankylosis.

X-ray of the spine shows a characteristic appearance of a 'bamboo spine' (ossification of interspinous ligaments). There is diffuse osteoporosis of the vertebral column. Erosion of vertebral bodies at the disc margin leads to 'squaring' of the vertebra.

- Dynamic MRI is highly sensitive and specific for identifying intraarticular inflammation, cartilage changes, and bone marrow oedema in sacroileitis.

Modified New York criteria for diagnosis of ankylosing spondylitis:

1. A history of back pain.
2. Limitation of motion of the lumbar spine.
3. Limited chest expansion.
4. Definite radiographic sacroiliitis.

Under these criteria, the presence of radiographic sacroiliitis plus any one of the other three criteria is sufficient for a diagnosis of definite ankylosing spondylitis.

The detection of HLA B27 is useful only as a diagnostic adjunct, since the presence of B27 is neither necessary nor sufficient for the diagnosis, but it can be helpful in patients who have not yet developed radiographic sacroiliitis.



Treatment

- There is no definite treatment for ankylosing spondylitis. An exercise programme may be designed in order to maintain functional mobility. Anti-inflammatory agents may be given to achieve sufficient relief of symptoms
- Indication for surgery in patients with ankylosing spondylitis is severe hip joint arthritis, when total hip arthroplasty may be done
- Attacks of acute anterior uveitis are usually effectively managed with local glucocorticoid administration in conjunction with mydriatic agents

- Methotrexate and sulphasalazine may be beneficial in some cases
- *Infliximab* (Chimeric Human/Mouse Anti-TNF-2 monoclonal antibody)

It is given in a dose of 5 mg/kg IV infusion, repeated at 2 weeks, 6 weeks and then at 8 weeks interval.

- *Etanercept* (Soluble P75 TNF- α receptor-IgG fusion protein)

It is given in a dose of 25 mg SC bid.

Both the above drugs have shown rapid, profound and sustained reductions in all clinical and lab measures of disease activity.

Diffuse Idiopathic Skeletal Hyperostosis (DISH)

- DISH occurs in the middle age and elderly
- Usually asymptomatic and may have stiffness
- Ligamentous calcification and ossification
- 'Flowing Wax'-appearance on the anterior bodies of the vertebra as a result of anterior spinal ligament calcification
- Intervertebral disc spaces are preserved
- Sacroiliac and apophyseal joints appear normal.

Reiter's Disease

It is characterised by a triad of seronegative oligoarthritis, conjunctivitis and nonspecific urethritis, 1–3 weeks following bacterial dysentery or exposure to sexually transmitted disease. Arthritis occurring alone following sexual exposure or enteric infection is known as reactive arthritis.

Arthritogenic Bacteria in Reactive Arthritis

1. Salmonella
2. Shigella
3. Campylobacter
4. Yersinia
5. Chlamydia.



Clinical Features

1. It presents with monoarthritis of a knee or an asymmetrical inflammatory arthritis of interphalangeal joints.
2. Patients can have heel pain, Achilles tendinitis or plantar fasciitis with presence of circinate balanitis. The presence of rash of keratoderma blennorrhagica is diagnostic of Reiter's disease in the absence of classical triad.
3. Skin lesions are faint macules, vesicles and pustules on the hands and feet to marked hyperkeratosis with plaque like lesions spreading to scalp and trunk.



4. Dystrophy of nail and massive subungual hyperkeratosis may be seen.
5. Ocular involvement (mild bilateral conjunctivitis) subsides spontaneously within a month. Iritis can occur in 10% of cases.
6. Symptomatic urethritis (mild dysuria and clear sterile discharge) is seen in most cases.
7. Self-limiting arthritis is seen in all cases
8. The extra-articular features are:
 - a. Conjunctivitis
 - b. Iritis
 - c. Aortic regurgitation
 - d. Cardiac conduction defects
 - e. Peripheral neuropathy.



Investigations

1. Raised ESR
2. Normocytic, normochromic anaemia and polymorphonuclear leukocytosis are present in peripheral smear
3. Rheumatoid factor and ANA are negative
4. HLA-B27 is seen in more than 70% of cases
5. Periarticular osteoporosis, reduction of joint space and erosive changes are the radiological features
6. Low viscosity inflammatory effusion with leucocyte count of 50,000/cumm and sterile on culture are seen in synovial fluid analysis.



Treatment

1. Rest
2. Analgesics
3. Local corticosteroids are useful in the case of iritis
4. The nonspecific urethritis is treated with a short course of tetracycline
5. Sulfasalazine or methotrexate may be beneficial in some cases.
6. Glucocorticoid therapy may be required to prevent rapid joint destruction.

Psoriatic Arthritis

It is a seronegative inflammatory arthritis and associated with characteristic changes in the nails (pitting and transverse ridges). It occurs in about 1/1000 of the general population and in 7% of patients with psoriasis.



Clinical Features

- Asymmetrical oligoarthritis (70%)
- Sacroiliitis/spondylitis (40%)

- Symmetrical seronegative arthritis (15%)
- Distal interphalangeal joint arthritis (15%)
- Arthritis mutilans.

Extra-articular Features

1. Scaly skin lesions are seen over extensor surfaces (scalp, natal cleft and umbilicus)
2. The nail changes are pitting, onycholysis, sub-ungual hyperkeratosis and horizontal ridging.



Investigations

1. Normochromic normocytic anaemia
2. Raised ESR
3. Test for RF and ANA are negative
4. The terminal IP joint involvement and relative periarticular osteoporosis are seen.



Treatment

1. Analgesics (NSAIDs)
2. Sulphasalazine and gold are used in persistent symptomatic cases without exacerbation
3. Chloroquine and hydroxychloroquine are used
4. Retinoid etretinate 30 mg/day is effective for both arthritis and skin lesions
5. Photochemotherapy with methoxy psoralen and long wave ultraviolet light (PUVA) are used for severe skin lesions
6. Methotrexate can also be given
7. Leflunomide and TNF- α blockers may also have disease modifying effect.

Prognosis

It has better prognosis than rheumatoid arthritis.

Systemic Lupus Erythematosus (SLE)

It is a multisystem connective tissue disease of unknown cause in which tissues and cells are damaged by pathogenic autoantibodies and immune complexes.

It is more common in women of child bearing age (male: female is 1 : 9).

Aetiology and Pathogenesis

1. There is disturbance of immune regulation.
2. Genetic factors are involved (HLA-B8 and DR3)
3. Involvement of environmental factors (sunlight).
4. *Drugs*: oestrogens, oral contraceptives, quinidine, INH, hydralazine, chlorpromazine, practolol, methyl dopa, phenytoin, a interferon and procainamide (most frequent).



5. Infection is thought to be one of the aetiological factors- EB virus.
6. Immunologically-mediated tissue damage, also results.
7. Miscellaneous: Ingested alfalfa sprout and chemicals like hydrazines, hairdyes are also implicated.

Autoantibodies in SLE

Antinuclear antibodies	(95%)
Anti-DNA-histone (and LE cells)	(70%)
Anti-DNA-(single strand)	(70%)
Anti-DNA-(double strand)	(70%)
Anti-RNA	
Anti-Sm	(30%)
Anti-UI-RNP	(40%)
Anti-Ro/SS-A	(30%)
Anti-La/SS-B	(10%)
Anti-cardiolipin	(50%)
Anti-erythrocyte	(60%)
Anti-lymphocyte	(70%)
Anti-platelet	(50%)
Anti-neuronal	(60%)
Anti-MA	
Anti-PCNA	

Criteria for the Diagnosis of SLE

1. Malar rash
2. Photosensitivity
3. Oral/nasopharyngeal ulcers
4. Arthritis involving >2 peripheral joints
5. Serositis – pleura/pericardium
6. Renal involvement
7. Neurological manifestations – seizure/psychosis
8. Haematological disorders
 - Leucopenia - < 4000/ μ L
 - Lymphopenia - < 1500/ μ L
 - Thrombocytopenia - < 1,00,000/ μ L
9. Immunological markers
 - Antinuclear/antiphospholipid/Anti ds DNA/Anti Sm

For diagnosis 4 or more criteria should be present either serially or simultaneously.

WHO - Classification of Lupus Nephritis

Grade	Histological changes
I	No histological changes
II	Proliferative changes confined to the mesangium
III	Proliferative changes 10-50% of glomeruli
IV	Proliferative glomerulonephritis >50% of glomeruli
V	Membranous changes with various degree of proliferation
VI	End stage scarred glomeruli



Investigations

1. Elevated ESR
2. *Peripheral smear*: normocytic, normochromic anaemia of chronic disease, leucopenia and thrombocytopenia.
3. Coombs' test may be positive (haemolytic anaemia)
4. *Anti-nuclear antibodies (ANA)*: Detection of ANA is more sensitive for diagnosing SLE. They can be detected by indirect immunofluorescence in the serum of more than 90% of patients.
 - Conditions with positive ANA*
 - a. SLE
 - b. Polymyositis
 - c. Rheumatoid arthritis
 - d. Scleroderma
 - e. Sjögren's syndrome
 - f. Myasthenia gravis
 - g. Fibrosing alveolitis
 - h. Chronic liver disease
 - i. Polyarteritis
 - j. Leukaemia.
5. *Antibodies to double stranded DNA (anti-dsDNA)*: These are more specific for the diagnosis of SLE and can be detected by radioimmunoassay.

A recent increase in anti-DNA double strand (dsDNA) antibodies indicates a flare. Antibodies to Sm are also specific for SLE and assist in diagnosis and Sm antibodies do not usually correlate with disease activity.

6. *Evidence of activation of classical complement pathway* (High levels of anti-DNA antibodies, low C₃ and C₄) are seen.
7. *Organ biopsies and lupus band test* (immunofluorescence at the dermoepidermal junction of normal skin due to the presence of immune complexes, complement components and immunoglobulins) are also diagnostic.
8. *Lupus anticoagulants*: This is an anticardiolipin antibody detected either by a prolongation of the partial thromboplastin time which is not correctable by the addition of normal plasma, or by a prolongation of dilute prothrombin time. These are detected by ELISA also and are responsible for thrombocytopenia and recurrent abortions especially in the first trimester.

Lupus anticoagulants also occur in other immunological disorders, HIV infection, or in association with drugs like chlorpromazine, procainamide, and hydralazine.



Clinical Features

System Involved	Manifestations
1. Skin	Fixed, erythematous rash over malar regions (Butterfly rash) (Fig. 10.6), discoid rash, alopecia, diffuse maculopapular rash, urticaria, erythema multiforme, lichen planus like lesions, photosensitivity, psori form lesions (subacute cutaneous lupus), oral ulcers, vasculitis
2. Renal	Proteinuria, nephrotic syndrome, focal, proliferative glomerulonephritis, hypocomplementemia and renal failure.
3. Nervous system	Meninges, spinal cord, cranial and peripheral nerves are involved. Patients can have cognitive dysfunction, organic brain syndromes (psychosis, neurosis), pseudotumour cerebri, extrapyramidal and cerebellar involvement. Hypothalamic dysfunction causes inappropriate ADH secretion.
4. Vascular	Thrombosis can occur due to vasculitis, antibodies against phospholipids (lupus anticoagulant, anti cardiolipin antibodies), and immune complex mediated destruction.
5. Hematological	Anaemia of chronic disease, leucopenia, mild thrombocytopenia.
6. Cardiopulmonary	Pericarditis, pericardial effusion, constrictive pericarditis, myocarditis (arrhythmias, CCF) sudden death due to MI, and Libman-Sachs' endocarditis causing MR or AR. Pleurisy and pleural effusion are common. Lupus pneumonia, interstitial fibrosis, pulmonary hypertension and ARDS can occur.
7. Gastrointestinal	Nausea, diarrhoea, vague discomfort, lupus peritonitis, vasculitis of intestine, intestinal perforation, GI motility disorders and intestinal pseudo obstruction.
8. Ocular	Retinal vasculitis, conjunctivitis, episcleritis and blindness can occur (fundus shows sheathed, narrow retinal arterioles and cystoid bodies) (Figs 10.7 and 10.8).
9. Musculoskeletal system	Myopathy, myositis and ischaemic bone necrosis are common; Arthritis, arthralgia which can be transient or persistent leading to chronic inflammatory arthritis and tenosynovitis causing deformities and contractures.
10. Systemic	Fatigue, malaise, fever, anorexia, and weight loss can occur.



Fig. 10.6: Butterfly rash in SLE

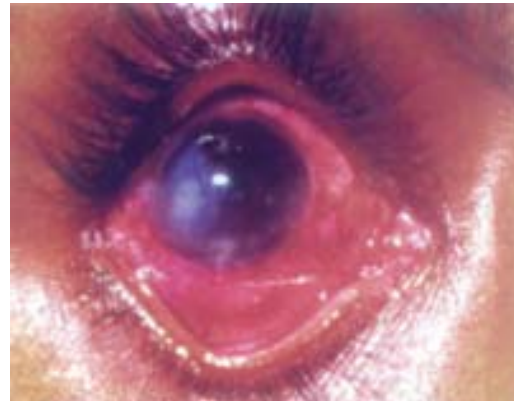

Fig. 10.7: SLE—Sclerokeratitis



Fig. 10.8: Retinal vasculitis in SLE

Pregnancy and SLE

The disease flares up during pregnancy, more so, around 6 weeks postpartum.

Pregnant women are prone for preeclampsia due to multiple placental infarctions. They are also prone for recurrent abortions. Child may be born with transient rashes, congenital complete heart block due to trans-



mission of maternal anti-Ro antibodies across the placenta (*neonatal lupus*).



Treatment

- No intervention of pregnancy is needed.
- Low dose aspirin should be given daily along with high dose steroids and subcutaneous heparin twice daily in full anticoagulating doses. Placental enzyme 11- β -dehydrogenase 2, deactivates glucocorticoids and it is more effective in deactivating prednisone/prednisolone than the fluorinated glucocorticoids—dexamethasone and betamethasone. Therefore, maternal SLE should be controlled with prednisone/prednisolone at the lowest effective doses for the shortest time required.

Tests that can Confirm Clinical Diagnosis and Predict Severity

Specific for SLE

Anti-dsDNA
Anti-sm.

Nonspecific

ANA (most sensitive)
Anti-Ro
Direct Coombs' test
VDRL (due to anti-cardiolipin antibodies)
PTT
Anticardiolipin
Hematocrit
WBC count
Platelet count
Urinalysis
Serum creatinine.

Test Helpful in Following the Clinical Course

Titre of anti-ds DNA
Serum complement levels
ESR
Haematocrit
WBC count
Platelet count
Urinalysis
Serum creatinine.



Management

There is no complete cure for SLE. Only symptomatic treatment can be given.

- For acute, life-threatening manifestations, prednisolone 40–80 mg/day can be given (1–2 mg/kg/day and maintained with a dose of 15 mg/day).
- Pulse therapy with methylprednisolone (1 gm IV on 3 consecutive days) can be tried for patients with proliferative glomerulonephritis and deteriorating renal function.
- NSAIDs are used for joint manifestations.
- Antimalarials like hydroxychloroquine in a dose of 400 mg/day are useful in skin and joint manifestations. It can be given for a few weeks and routine ophthalmic checkup is mandatory.
- Immunosuppressive and cytotoxic drugs are useful in resistant cases and it is tried along with plasma exchange.

Indications for immunosuppressive therapy

- Life-threatening manifestations of SLE like glomerulonephritis, CNS involvement, thrombocytopenia and haemolytic anaemia.
 - Inability to reduce corticosteroid dosage or severe corticosteroid side effects.
Azathioprine, (in a dose of 2–3 mg/kg orally) or cyclophosphamide (10–15 mg/kg once a month as a pulse dose or 1.5–2.5 mg/day IV) or chlorambucil can be used.
- Anticoagulation should be given to prevent clotting when needed. Chronic warfarin therapy to prevent venous clotting can be given along with plasmapheresis.
 - Antibodies to T lymphocyte, total lymph node irradiation, IV gammaglobulin, cyclosporine and fish oil have been tried experimentally.
 - Mycophenolate mofetil and rituximab have also been used in severe SLE.

Prognosis

Five-year survival rate is more than 90%. Patients with severe renal, pulmonary and neurological involvement have worst prognosis. Infection as a result of immunosuppression is an important cause of morbidity. Pregnancy is not contraindicated when the patient is in remission especially when other organ systems are not involved.

Drug Induced Lupus

Drugs causing SLE like syndromes have already been mentioned. There is genetic predisposition. ANA is positive in 75% of the patients especially with procainamide.

Antibodies to dsDNA and hypocomplementemia are rare. It is treated by withdrawing the offending drug



and by putting the patients on steroids for 2 to 10 weeks.

In patients with idiopathic SLE, drugs causing SLE can be used safely.

Antibodies to histones are more specific for drug induced lupus.

Drugs Causing Lupus

1. Anti-arrhythmics
 - Procainamide
 - Disopyramide
 - Propafenone
2. Anti-hypertensives
 - Hydralazine
 - ACE inhibitors
 - Beta-blockers
3. Antithyroid drugs
 - Propylthiouracil
4. Antipsychotics
 - Chlorpromazine
 - Lithium
5. Anticonvulsants
 - Carbamazepine
 - Phenytoin
6. Antibiotics
 - Isoniazid
 - Minocycline
 - Macrodantin
7. Diuretics
 - Hydrochlorthiazide
8. Anti-hyperlipidemics
 - Lovastatin
 - Simvastatin
9. Interferons
10. TNF inhibitors.

Mixed Connective Tissue Disease

Mixed connective tissue disease (MCTD) is an overlap syndrome characterised by a combination of clinical features similar to those of systemic lupus erythematosus (SLE), scleroderma, polymyositis and rheumatoid arthritis.

The aetiological and pathogenic mechanisms of MCTD remain unknown. They are however, characterised by presence of the following immunological findings in the serum

1. High titres of antibody to nuclear ribonucleoprotein (RNP) antigen.
2. Circulating immune complexes during active disease.
3. Deposition of IgG, IgM, and complement within vascular walls and glomerular basement membrane.

4. Widespread lymphocytic and plasma cell infiltration of numerous tissues.

There are vascular lesions with intimal proliferation and medial hypertrophy, resulting in narrowing of the lumen of large vessels and of small arterioles of many organs.



Clinical Features

- This disorder may be seen in the mean age of 30 to 40 years.
- Approximately 80% of patients are females.
- Typical clinical features include:
 - a. Raynaud's phenomenon
 - b. Polyarthritis (resembles rheumatoid arthritis, but is nondeforming)
 - c. Swollen hands or sclerodactyly
 - d. Esophageal dysfunction (reduced upper and lower esophageal sphincter pressures and decreased peristalsis in the distal two-thirds of the oesophagus)
 - e. Pulmonary fibrosis (reduced diffusing capacity and development of pulmonary hypertension)
 - f. Cardiac involvement (pericarditis, mitral valve prolapse, myocarditis, aortic insufficiency)
 - g. Inflammatory myopathy.
 - h. Nonscarring alopecia
 - i. Lupus-like rashes
 - j. Periungual telangiectasia.

Diagnosis

Diagnosis is confirmed by detection of unusually high titres of circulating antibody to a nuclear ribonucleoprotein (RNP) antigen.



Treatment

Salicylates and other nonsteroidal anti-inflammatory agents may be used for relief of symptoms. Glucocorticoids (1 mg/kg/day of prednisone) may be given if the disease is severe and there is significant involvement of major organ systems.

Progressive Systemic Sclerosis

This is a generalised disorder of connective tissue characterised by fibrosis and degenerative changes in the skin (scleroderma) and many internal organs.

The aetiology is unknown, but may be due to immunologically determined inflammation causing intimal thickening of small blood vessels and excessive production and cross-linking of collagen. It is associated



with HLA haplotype AI B8 DR3 and so may be a genetically predisposed disorder.

Women are affected four times more frequently than men. This disorder is found to occur in the third to fifth decades.

Classification of Scleroderma

- I. Systemic sclerosis
 - a. Limited cutaneous disease
 - b. Diffuse cutaneous disease
 - c. Sine scleroderma
 - d. Undifferentiated connective tissue disease
 - e. Overlap syndrome
- II. Localized scleroderma
 - a. Morphea
 - b. Linear scleroderma
 - c. En Coup De Sabre
- III. Chemically induced scleroderma like disorders
 - a. Toxic oil syndrome
 - b. Vinyl chloride induced disease
 - c. Bleomycin induced fibrosis
 - d. Pentazocine induced fibrosis
 - e. Epoxy and aromatic hydrocarbons induced fibrosis
 - f. Eosinophilia – myalgia syndrome
- IV. Other scleroderma like disorders
 - a. Scleredema Adultorum of Buschke
 - b. Scleromyxedema
 - c. Chronic Graft-vs-Host disease
 - d. Oeosinophilic fasciitis
 - e. Digital sclerosis in diabetes
 - f. Primary amyloidosis
 - g. Amyloidosis associated with multiple myeloma.



Fig. 10.9: Raynaud's phenomenon



Fig. 10.10: Scleroderma—microstomia



Clinical Features

Severe Raynaud's phenomenon is usually the presenting complaint and may precede other features of the disease by months or years.

1. Skin Changes (Figs 10.10 and 10.11)

Initially there is often a well demarcated non-pitting oedema and induration associated with 'sausage' swelling and restriction of movement of the fingers. Later the skin becomes shiny with atrophy and ulceration of the fingertips with or without associated calcinosis (Fig. 10.11). The skin of the face, limbs and trunk is affected and there may be associated pigmentation and telangiectasia. As the disease advances, the face may become



Fig. 10.11: Scleroderma-pitted scars in fingertips



taut and 'mask-like' with 'beaking' of the nose and difficulty in opening the mouth (microstomia) (Fig. 10.9). Tightening of skin over bony prominences results in flexion contractures.

The severity of the disease can be assessed by measurement of the maximal oral aperture (MOA), which is the distance between the borders of the upper and lower lips with the mouth widely open. The mean average MOA in normal individuals is 5.8 ± 0.4 cm. In patients with diffuse disease, the MOA tends to become progressively smaller and eventually often measures less than 3.5 cm.

2. Musculoskeletal Manifestations

There is arthralgia and a mild non-erosive inflammatory arthritis. Due to inflammation of the muscle tendons, a 'leathery' crepitus may be palpable over the affected tendon sheaths or joints on movement.

Proximal muscle weakness and wasting may result from a low-grade myositis.

3. The Gastrointestinal Tract (Fig. 10.12)

This is involved in the majority of patients. There is involvement of the lower two thirds of the oesophagus resulting in loss of oesophageal peristalsis and dysphagia. On progression of the disease, there is loss of tone of the lower oesophageal sphincter, resulting in reflux oesophagitis. Dilatation of segments of large and small bowel may occur less frequently, causing intermittent abdominal pain, constipation, distension, obstruction and malabsorption. Systemic sclerosis may be associated with primary biliary cirrhosis.



Fig. 10.12: Scleroderma—dilated oesophagus (with absent motility)



Fig. 10.13: Pulmonary fibrosis in scleroderma

4. Pulmonary Manifestations

Pulmonary interstitial fibrosis occurs in the majority of patients, affecting predominantly the lower lobes. This may lead to defective gaseous diffusion. Progressive fibrosis may occur leading to increasing dyspnoea on exertion and a restrictive pattern of impaired lung function, and ultimately to the development of pulmonary hypertension and right ventricular failure (Fig. 10.13).

5. Cardiac Manifestations

Cardiac involvement may be characterised by the development of pericarditis, cardiomyopathy, heart block, or aortic valve lesions. Ischaemic heart disease may occur due to vasospasm of the coronary arteries. Left ventricular failure may occur secondary to hypertension.

6. Renal Involvement

The kidneys may be involved at any stage of the disease and is an important cause of morbidity and mortality. There is intimal hyperplasia of the interlobular arteries, fibrinoid necrosis of the afferent arterioles, including the glomerular tuft, and thickening of the glomerular basement membrane. This change results in the development of renin induced hypertension.

7. Other sites of Involvement

- Lymphocytic infiltration of minor salivary glands may occur leading to xerostomia (dry mouth).
- Hypothyroidism occurs in a significant number of patients and may be associated with high levels of antithyroid antibodies.
- Trigeminal neuralgia may occur.



Difference Between Diffuse and Limited Type

	<i>Diffuse</i>	<i>Limited</i>
Skin involvement	Face, Trunk, Distal and Proximal extremities	Face, Distal to elbows
Raynaud's phenomenon	Onset within 1 year or at times of skin changes	May precede skin disease by years
Organ involvement	Pulmonary interstitial fibrosis Renovascular hypertensive Crisis, (dysphagia) lower 2/3 of oesophagus with loss of cardiac sphincter tone	Pulmonary hypertension after 10-15 years of disease, Biliary cirrhosis
Nail fold capillaries	Dilatation and dropout	Dilatation without significant dropout
Antinuclear antibodies	Anti-topoisomerase-1	Anti-centromere

Diagnosis

Antinuclear antibodies are seen in about 50% of patients. Antibodies to single stranded RNA and to an extractable nuclear antigen (anti-Scl-70) are seen in 20% of patients and may be a marker for pulmonary involvement.

Autoantibodies in Systemic Sclerosis (SSc)

<i>Autoantibody</i>	<i>Clinical association</i>
Anti-topoisomerase - 1	Diffuse cutaneous SSc
Anti-centromere	Limited cutaneous SSc
Anti-RNA Polymerase I, II, III	Diffuse cutaneous SSc
Anti- Th RNP	Limited cutaneous SSc
Anti-U ₁ RNP	Limited cutaneous SSc
	Mixed connective tissue disease
Anti- U ₃ RNP	Diffuse and limited cutaneous SSc
	Skeletal myopathy
	Pulmonary arterial hypertension
Anti- PM / scl	Overlap (SSc, Polymyositis)

alleviate Raynaud's phenomenon. β -blockers are contraindicated in treating hypertension, as they may precipitate Raynaud's phenomenon.

GI involvement – H₂ –receptor antagonists, proton pump inhibitors, and promotility agents have been used. Metoclopramide may reduce bloating and distention. Cardiopulmonary involvement – Calcium channel blockers for coronary artery vasospasm and cyclophosphamide for progressive pulmonary parenchymal disease are useful.

The CREST Syndrome

This comprises a subset of patients with systemic sclerosis whose disease is limited to manifestation of calcinosis. Raynaud's phenomenon, oesophageal involvement, sclerodactyly and telangiectasia. An anti-centromere antinuclear antibody with specificity for a protein of the chromosomal kinetochore is present in the serum.

Morphoea and Linear Scleroderma

Morphoea refers to localised involvement of the skin. The sclerodermal changes in the skin and subcutaneous tissue are localised to parts of the body.

Linear scleroderma refers to involvement of a limb or part of the body.

These lesions have minimal or no systemic involvement.

Serological findings are similar to those of systemic sclerosis.

The Vasculitis Syndromes

Vasculitis is a clinicopathological process characterised by inflammation and damage to blood vessels. The vessel lumen is compromised and is associated with ischaemia of the tissues supplied by the involved vessel.



Management

D-Penicillamine has been reported to reduce skin thickening and prevent development of significant organ involvement. This drug interferes with inter- and intramolecular cross-linking of collagen and is also immunosuppressive. It is usually started with a dose of 250 mg/d and then increased at 1 to 3 month intervals up to 1.5 g/d as tolerated.

Glucocorticoids are indicated in those patients with inflammatory myositis or pericarditis with a dose of 40 to 60 mg/d of prednisone. The steroid may then be tapered based on clinical improvement.

Systemic hypertension, if present, should be treated with drugs such as α -methyl dopa, calcium channel blockers (nifedipine, verapamil or diltiazem) or ACE inhibitors (captopril or enalapril), as these drugs may



Mechanisms of Blood Vessel Damage

1. *Immunopathogenic*
 - a. Immune complex formation in situ
 - b. Antibody mediated cell damage (endothelium and blood vessel tissue)
 - c. Cytotoxic T cells against the components of blood vessel and granuloma formation in or around vessel wall.
 - d. Cytokine induced expression of adhesion molecules for WBCs on endothelial cells.
2. *Nonimmune mechanisms*
 - a. Infiltration of vessel wall by microbial agents
 - b. Unidentified.

Classification

- i. Pathogenic immune complex formation/deposition.
 - Henoch-Schonlein purpura
 - Vasculitis associated with collagen vascular diseases
 - Serum sickness and cutaneous vasculitis syndromes
 - Hepatitis C – associated essential mixed cryoglobulinemia
 - Hepatitis B – associated polyarteritis nodosa
- ii. Production of antineutrophilic cytoplasmic antibodies.
 - Wegener's granulomatosis
 - Churg-Strauss syndrome
 - Microscopic polyangitis
- iii. Pathogenic T lymphocyte responses and granuloma formation.
 - Giant cell arteritis
 - Takayasu's arteritis
 - Wegener's granulomatosis
 - Churg-Strauss syndrome

Conditions that Mimic Vasculitis (Vasculitis Mimics)

- I. Infectious diseases
 1. Bacterial endocarditis
 2. Disseminated gonococcal infection
 3. Pulmonary histoplasmosis
 4. Coccidioidomycosis
 5. Syphilis
 6. Lyme disease
 7. Rocky mountain spotted fever
 8. Whipple's disease
- II. Neoplasms
 1. Atrial myxoma
 2. Lymphoma
 3. Carcinomatosis

- III. Drug toxicity
 1. Cocaine
 2. Amphetamine
 3. Ergot alkaloids
 4. Methysergide
 5. Arsenic
- IV. Coagulopathies
 1. Antiphospholipid antibody syndrome
 2. Thrombotic thrombocytopenic purpura
- V. Sarcoidosis
- VI. Atheroembolic disease
- VII. Goodpasture's syndrome
- VIII. Amyloidosis
- IX. Migraine
- X. Cryofibrinogenemia.

Polyarteritis Nodosa

It is an uncommon disease with a mean age of onset around 50 years with a slight male preponderance.

There is necrotizing inflammation of small and medium sized muscular arteries. The lesions are segmental and involves bifurcations and branchings, spreading circumferentially to involve adjacent veins. However, there is no involvement of venules. In acute stages, there is infiltration by polymorphs and in chronic disease, mononuclear cells predominate. There is thrombosis and infarction of tissues supplied by the vessel involved. Aneurysmal dilatation of up to 1 cm along the involved arteries are characteristic of PAN (Fig. 10.14).

The pathology in the kidney in classic polyarteritis nodosa is that of arteritis without glomerulonephritis.

Pulmonary Arteries are Characteristically not Involved

It can be associated with Hepatitis B infection and hairy cell leukaemia due to common immunological mechanisms.

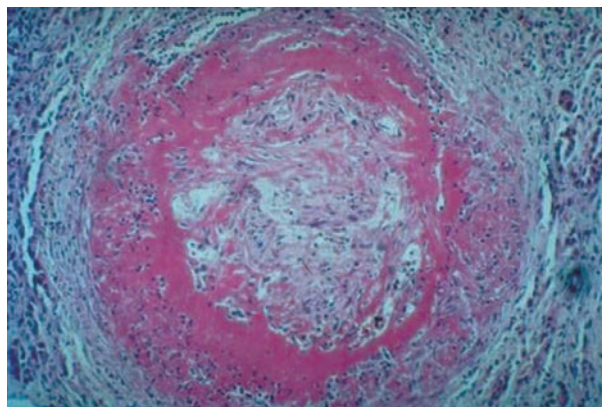

Fig. 10.14: Polyarteritis nodosa



Fig. 10.15: Vasculitis—dry gangrene



Investigations

1. Peripheral smear
 - a. Total count elevated along with increased polymorphs
 - b. Anaemia of chronic disease
2. Elevated ESR
3. Hypergammaglobulinaemia
4. HBs Ag positivity in 30% of patients
5. Characteristic vasculitis in biopsy of involved organs (Figs 10.15 and 10.16).
6. Positive ANCA is found in less than 20% of patients with classic PAN
7. In the absence of easily accessible tissue for biopsy, the angiographic demonstration of involved vessels, particularly in the form of aneurysm of small and medium sized arteries, in the renal, hepatic, and visceral vasculature is sufficient to make the diagnosis.



Fig. 10.16: Vasculitis—dry gangrene

Clinical Manifestations in PAN

Organ System Involved	Clinical Features
1. Renal	Renal failure, hypertension (renal ischaemia)
2. Musculoskeletal	Arthritis, arthralgia, myalgia
3. Peripheral nervous system	Peripheral neuropathy, mononeuritis multiplex
4. GIT	Abdominal pain, nausea, vomiting, bowel infarction, perforation, liver and pancreatic infarction
5. Skin	Purpura, cutaneous infarcts, livedo reticularis, rash, Raynaud's phenomenon
6. Cardiac	CCF, MI, Pericarditis
7. CNS	CVA, seizures, altered mental state
8. Genitourinary	Testicular, ovarian, epididymal pain

- Aneurysm of vessels are not pathognomonic of PAN.
8. Biopsy of symptomatic organs such as nodular skin lesions, painful testes, nerve, muscle provide highest diagnostic yields.



Treatment

Prednisone 1 mg/kg/day along with cyclophosphamide 2 mg/kg/day. This regimen gives long-term remission in 90% of patients.

PAN associated with HBV infection can be managed with Vidarabine combined with plasma exchange with or without glucocorticoids or using interferon α and plasma exchange.

If life-threatening manifestations are present, a short course of high dose pulse therapy with methylprednisolone 500 mg IV bid for 5 days.

When major organs (Lungs, kidneys, CNS) are involved, immunosuppressives like oral cyclophosphamide are used.

Prognosis

In untreated cases, prognosis is extremely poor. Disease can become fulminant or progress relentlessly. Death results from renal failure, bowel perforation or cardiovascular causes.

- Five-year survival rate—13 %
- Five-year survival with treatment (steroids)—40%.
- Following successful treatment relapse can occur in 10 % of cases.



Churg-Strauss Disease (Allergic Angiitis or Granulomatosis)

It is a disease characterised by granulomatous vasculitis of multiple organ system especially of lung (which is less frequently involved in classical PAN).

The disease can occur at any age except in infants. Male to female ratio is almost equal.

Pathophysiology

Pattern of involvement is similar to PAN but capillaries, veins and venules are also involved in this disease with lung involvement. Granulomas are present on the tissues of organs involved or over the vessel itself. Infiltration with eosinophils is common (associated with asthma).



Clinical Features

Fever, malaise, anorexia and weight loss are common. Lung involvement dominates the clinical picture (asthma and pulmonary infiltrates are common). Renal involvement is less frequent.

Mononeuritis multiplex is the second most commonest presentation in 70 % of cases.

Diagnosis

1. *Biopsy*: Granulomatous vasculitis with eosinophilic infiltrations of tissue
2. Peripheral eosinophilia (> 1000 cells/ μ L)
3. X-ray may show fleeting pulmonary infiltrates
4. P-ANCA is positive in 40 % of cases.



Treatment

Glucocorticoids are used as the first line of therapy. If this fails, cyclophosphamide along with alternate day prednisolone can be given.

Prognosis

- Five-year survival rate is 25%.
- Cause of death is related to pulmonary or cardiac disease.

Wegener's Granulomatosis (WG)

It is a distinct clinicopathological entity characterised by granulomatous vasculitis of upper and lower respiratory tracts together with glomerulonephritis.

Incidence

It is an uncommon disease occurring in both males and females.

Pathophysiology

Histopathological hallmarks are necrotizing vasculitis of small arteries and veins together with granuloma formation which can be intra or extravascular.

Lungs show multiple, bilateral, nodular cavitory infiltrates which on biopsy shows typical necrotizing granulomatous vasculitis. Later there may be obstruction with atelectasis.

Majority of the patients with WG develop anti-neutrophil cytoplasmic antibodies (ANCA). This refers to coarse granular pattern observed by immunofluorescent microscopy.

These are sensitive and specific markers for WG.

Bronchoalveolar lavage shows increased number of neutrophils.



Clinical Features

Paranasal sinusitis, sinus pain with drainage of purulent or bloody nasal discharge with or without nasal mucosal ulceration.

Nasal septal perforation causes saddle nose deformity. Patients may have fever, weight loss and joint pain.

Systemic Manifestations

Kidney	Glomerulonephritis
ENT	Sinusitis, nasal disease, otitis media, hearing loss, oral lesions
Lung	Pulmonary infiltrates, nodules, hemoptysis, pleuritis
Eyes	Conjunctivitis, scleritis, dacryocystitis, proptosis, pain in the eyes, retinal involvement
Others	Arthralgias or arthritis, fever, cough, skin abnormalities, weight loss $> 10\%$ of body weight, peripheral neuropathy, pericarditis, hyperthyroidism



Investigations

1. Markedly increased ESR
2. Mild anaemia
3. Leukocytosis in the peripheral smear
4. Hypergammaglobulinaemia (IgA)
5. Rheumatoid factor may be positive



6. Thrombocytosis (as acute phase reactant)
7. Diagnosis is confirmed by lung and renal biopsy. The specimen shows characteristic vasculitic changes.
8. Elevated titres of ANCA (in 88% of patients with active disease and 45% of patients in remission).

The ANCA titre can be misleading. Many patients who achieve remission continued to have elevated titres for years. A rise in ANCA titre by itself is not a harbinger of immediate disease relapse and should not lead to reinstatement or increase in immunosuppressive therapy.



Differential Diagnosis

Lymphomatoid granulomatosis: In this condition there is infiltration of atypical lymphocytoid and plasmacytoid cells, in an angioinvasive manner. Fifty per cent of patients develop true malignant lymphoma.



Treatment

- Usually the condition is fatal within a few months without treatment.
- Cyclophosphamide in a dose of 2 mg /kg/day orally so as to maintain the WBC count at 1500/ μ l. Following induction of complete remission, it can be continued for 1 year. Along with this, glucocorticoids (prednisone) initially in a dose of 1 mg /kg/day for one month and later, on alternate days for 6 months can be given. Steroids can be discontinued within 6–12 months.
- There is marked improvement in 90% of patients and complete remission is achieved in 75% of patients.
- Azathioprine in a dose of 1–2 mg /kg/day can also be tried.
- Septran is shown to decrease relapses with regard to upper airway disease.
- Methotrexate and mycophenolate mofetil are used for post remission maintenance.

Temporal Arteritis (Giant Cell Arteritis, Cranial Arteritis)

It is an inflammation of medium and large sized arteries characterized by involvement of one or more branches of carotid artery especially temporal artery.

It is a disease of the elderly, occurring exclusively in older people > 55 years especially in females.

There is evidence of familial occurrence.

Pathology

Panarteritis with inflammatory mononuclear cell infiltrates with frequent giant cell formation occurs. There is proliferation of intima and fragmentation of internal elastic lamina.



Clinical Features

It is characterised clinically by fever, anaemia, raised ESR and headaches in an elderly patient. Patients may also have loss of appetite, loss of weight, sweats, malaise, arthralgias, polymyalgia rheumatica syndrome (stiffness, aching and pain in the muscles of neck, shoulders, hips and thighs).

They may present with scalp pain and jaw claudication.

On examination patients have tender, thickened, nodular arteries which may become cord like and pulseless and later get occluded. Another dreaded complication is chronic ischaemic optic neuritis causing visual impairment and sudden blindness. Strokes, MI, aortic aneurysms, dissections and infarctions of visceral organs also occur.



Investigations

1. Elevated ESR
2. Normochromic or hypochromic anaemia
3. Abnormalities in liver function test (\uparrow SAP)
4. Increased IgG and complement.
5. Temporal artery biopsy is done to confirm the diagnosis.

A therapeutic trial of glucocorticoid therapy results in dramatic response.



Treatment

Prednisone is given in a dose of 40–50 mg/day and gradually tapered to 7.5–10 mg/day and later changed to alternate day therapy for 1–2 years to prevent relapse.

Aspirin is used to reduce the cranial ischaemic complication.

ESR is a useful indicator of inflammatory activity and is useful in monitoring therapy.

Prognosis

Prognosis is good.

Takayasu's Arteritis (Aortic Arch Syndrome)

It is an inflammatory stenotic disease of medium and large sized arteries characterised by a strong predilection



for arch of aorta and its branches, ascending aorta and femorals especially at their origin. It is common in adolescent girls and young women associated with HLA-DR 2, MB1, HLA-DR4 and MB3.

The disease involves medium and large sized arteries with a predilection for aortic arch and its branches and also pulmonary arteries. Renal artery occlusion leads to hypertension.

There is marked intimal proliferation, fibrosis, scarring and vascularization of the media and disruption and degeneration of elastic lamina.



Clinical Features

It is a systemic disease with generalised as well as local symptoms. Generalised symptoms include malaise, fever, night sweats, arthralgias, anorexia, weight loss, and syncopal episodes. Strokes can occur.

There is pain over involved arteries and pulses are absent. AR, cardiomegaly, CCF due to hypertension (systemic or pulmonary) may also occur. Clinical course can be fulminant and death is usually due to CCF or CVA.

Artery	Clinical manifestations
Subclavian	Arm claudication, Raynaud's phenomenon
Common carotid	Visual changes, TIA, syncope, stuttering hemiplegia
Abdominal aorta	Abdominal pain, nausea, vomiting
Aortic arch or root	Aortic insufficiency or CCF
Vertebral	Visual changes, dizziness, diplopia, dysarthria, dysphagia
Coeliac axis	Abdominal pain, nausea, vomiting
Superior mesenteric	Abdominal pain, nausea, vomiting
Iliac	Leg claudication
Pulmonary	Atypical chest pain, dyspnoea
Coronary	Chest pain-myocardial infarction



Investigations

1. Elevated ESR
2. Mild anaemia
3. Elevated immunoglobulin
4. Aortogram.

Diagnosis

The diagnosis of Takayasu's arteritis should be suspected in a young woman who develops a decrease or absence of peripheral pulse, discrepancies in blood pressure and arterial bruits.



Treatment

Spontaneous remission is common. Glucocorticoids in a dose of 40–60 mg/day can be tried. Angioplasty can be done for stenosed vessels. In refractory cases methotrexate up to 25 mg/week can be given.

Kawasaki Disease (Mucocutaneous Lymph Node Syndrome)

It is an acute, febrile, multisystem disease of children characterised by unresponsiveness to antibiotics, non-suppurative cervical adenitis and changes in skin and mucous membrane such as oedema, congested conjunctivae, erythema of oral cavity, lips, palms and desquamation of skin of the fingertips. There is typical intimal proliferation with infiltration of mononuclear cells. Complications are common between 3rd and 4th weeks of illness.

Vasculitis and aneurysms of coronary arteries are common. Other manifestations include pericarditis, myocarditis, myocardial ischaemia, infarction and cardiomegaly.



Treatment

High dose IV gammaglobulin in a dose of 2 gm/kg as a single infusion over 10 hours together with aspirin 100 mg/kg/day for 2 weeks followed by 3–5 mg/kg/day for several weeks.

Prognosis

Three per cent develop fatal complications. Prognosis for uneventful recovery is excellent.

Behçet's Syndrome

It is a multisystem disorder presenting with recurrent oral or genital ulcers as well as ocular involvement.

Incidence

1 in 10,000 to 1 in 500,000.

Pathology

Autoimmune vasculitis, linked to HLA B5 and HLA-DR5.



Clinical Features

- Patients have recurrent aphthous ulcers which are 2–10 mm in size, painful, shallow or deep with central



necrotic material, occurring singly or in crops which can be located any where in the oral cavity. Genital ulcers resemble oral ones. Vaginal ulcers are painless. Genital ulcer does not affect glans- penis and urethra.

- Skin involvement is in the form of folliculitis, erythema nodosum, acne like exanthem, and vasculitis.
- Involvement of eyes may be in the form of posterior uveitis, iritis, retinal vessel occlusion and optic neuritis.
- Patients can have superficial and deep vein thrombosis, and SVC obstruction.
- CNS involvement causes benign ICT, multiple sclerosis like picture, pyramidal signs and psychiatric disturbances.
- Pulmonary artery vasculitis presents with dyspnoea, cough, chest pain, haemoptysis and infiltrates on chest X-rays
- The arthritis is not deforming and affects the knees and ankles.



Investigations

1. Elevated ESR

2. Elevated C reactive protein
3. Antibodies to oral mucosa.
4. *Pathergy test*: This is an abnormal inflammatory response to scratch or intradermal saline administration, which is not seen in normal individuals.

Diagnostic Criteria

In addition to recurrent oral ulcers if the patient has any two of the following criteria, the diagnosis is confirmed.

1. Genital ulcers
2. Skin lesions
3. Eye lesions
4. Pathergy test.



Treatment

- For mouth ulcers, topical steroids as paste or mouth wash.
- Analgesics for arthritis
- Aspirin 150 mg/day for thrombophlebitis
- Prednisone 1 mg/kg/day for uveitis
- In refractory cases, azathioprine in a dose of 2–3 mg/kg/day or cyclosporine A in a dose of 5–10 mg/kg/day can be tried.



Chapter 11

Oncology

SYMPTOMS

LOCAL

SYSTEMIC

NONMETASTATIC

METASTATIC

COMMON PRESENTATIONS

CHILDREN

Anaemia/fever/purpura

- Leukaemias

Mass in abdomen

- Nephroblastoma/

Leukaemia

Childhood cataract

- Retinoblastoma

ADULT MALE

Dry and persistent cough

with/without haemoptysis

- Ca. lung

New and persistent mass

- Lymphomas/sarcomas

Painless testicular swelling

- Testicular malign.

Painless jaundice

- Malignant obstruction

Worsening of jaundice in

a cirrhotic

- Hepatocellular ca.

ELDERLY MALE

Painless haematuria

- Urogenital tumours

Bladder symptoms

- Prostatic ca.

Altered bowel habits/abd. pain

unexplained iron def. anaemia

- GI malignancy

Chronic backache

- Secondaries/myeloma

Nonhealing ulcer anywhere

- Basal/squamous cell ca.

Hyperpigmented itchy lesion

- Melanoma

ADULT FEMALE

Breast mass/nipple discharge

- Carcinoma breast

Post menopausal bleeding PV

post coital bleeding

- Carcinoma cervix

Abdominal mass

- Ovarian tumours

THE PHYSICAL EXAMINATION

GENERAL EXAMINATION

Cachexia

Mental status

Pallor

Icterus

Clubbing

Pedal oedema

Lymph node enlargement

External markers of malignancy

Acanthosis nigricans

Erythema gyratum repens

Dermatomyositis

Cushingoid features

Circinate erythema

Acquired ichthyosis

Pachydermoperiostitis

Sweet's syndrome

Vitiligo

Hyperkeratosis

Migratory thrombophlebitis

Glucagonoma syndrome, etc.

VITAL SIGNS

LOCAL EXAMINATION

SYSTEM EXAMINATION

Cardiovascular system

Respiratory system

Gastrointestinal system

Nervous system

WORKING DIAGNOSIS

PERFORMANCE STATUS

INVESTIGATIONS

Diagnosis

Staging

Assessing prognosis

EXPLANATION TO THE PATIENT/RELATIVES

(about therapeutic options and complications)

TREATMENT/FUTURE PLAN

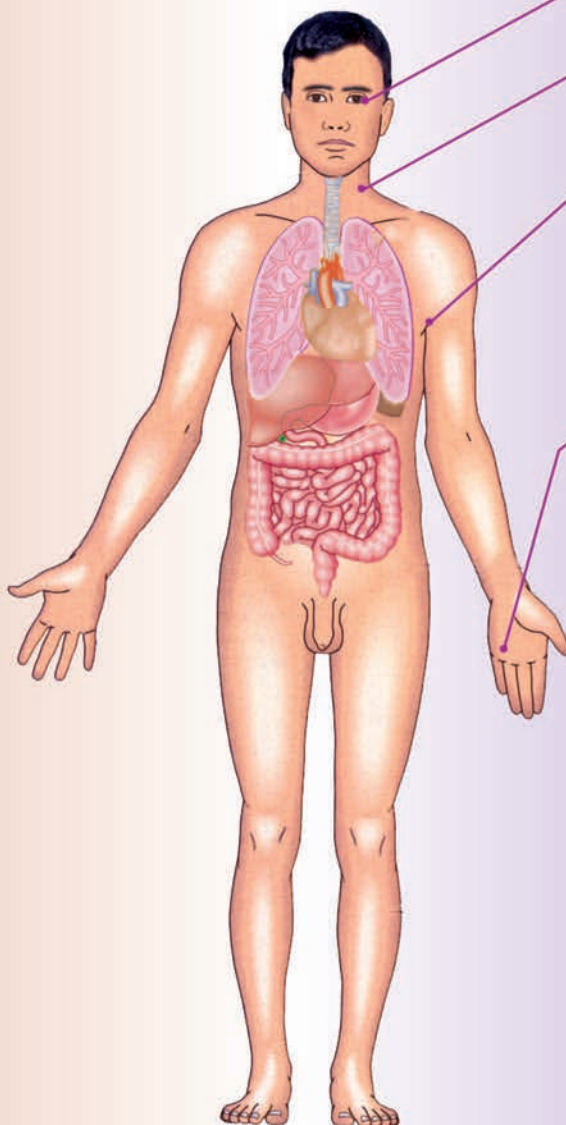

Basic Concepts

Oncology is the study of tumours. Neoplasia means abnormal new growth, which may be benign or malignant.

Cancer is the term used to describe a wide variety of malignant diseases. Cancer is second only to coronary artery disease as the most common cause of death. Nearly all cancers originate from a single cell.

Genes and Cancer

Cancer is a genetic disease: Cancer arises because of alterations in the DNA, which can be as a result of either random replication errors due to exposure to carcinogens or faulty DNA repair process.

Proto-oncogenes promote normal cell growth. Over activation of proto-oncogenes by point mutation, amplification or dysregulation results in the formation of *oncogenes*.

Genes that normally restrains cell growth are called tumour suppressors and unregulated cell growth occurs if their function is lost. Cancer can arise as a result of either over activation of oncogenes or loss of function of tumour suppressor genes. DNA repair genes can contribute to the development of malignancy through mutations involving oncogenes and tumour suppressor genes.

Tumour Suppressor Genes and Familial Cancers

Most of the genes responsible for the dominantly inherited cancer syndromes are tumour suppressor genes.

Mutations of Genes can Cause Cancer

Evidences that mutations can cause cancer include:

- Malignant tumours are clonal nature.
- Some cancers show Mendelian inheritance.
- DNA from malignant cell can some time transform normal cell to malignant phenotype.
- Most tumours contain somatic mutations in oncogenes/tumour suppressor genes.
- Recurring sites of chromosome change are observed in cancers at the site of genes involved in cellular growth control.
- Most carcinogens are mutagens.
- Defects in DNA repair increase the probability of cancer.

Selected Tumour Suppressor Genes Responsible for Familial Cancer Syndromes

Gene	Chromosome	Syndrome
PTC	9	Basal cell nevus
BRCA 1	17	Familial breast/ovarian cancer
BRCA 2	13	Familial breast cancer
p16	9	Familial melanoma
APC	5	Familial polyposis coli
RB	13	Familial retinoblastoma
WT1	11	Familial Wilms' tumour
EXT1	11	Hereditary multiple exostosis
p53	17	Li-Fraumeni (Sarcoma, breast cancer)
NF1	17	Neurofibromatosis type 1
NF2	22	Neurofibromatosis type 2
TSC2	16	Tuberous sclerosis
VHL	3	Von Hippel Lindau

Chromosomal Translocations can Cause Cancer

Translocation	Genes	Malignancy
(9:22)	ABL-BCR	CML
(3:21)	AML 1 EAP	AML
(11:14)	BCL 1 IgH	Mantle cell lymphoma
(14:18)	BCL 2 IgH	Follicular lymphoma
(1:7)	LCK TCRB	T cell ALL
(4:11)	MLL ALL 1 HRX	ALL
(8:14)	myc	Burkitt's lymphoma, T cell ALL
(7:9)	TAN 1	T cell ALL
(14:19)	BCL 3 IgH	B cell CLL

Cell Biology of Cancer

Cancer is most common in tissues with rapid turnover especially those exposed to environmental carcinogens and whose proliferation is regulated by hormones.

Tissues with rapid turnover:

- Skin
- Bone marrow
- Gut.

Tissues with no turnover: They persist throughout life without dividing or being replaced. Neoplasia in such tissues is rare.

- Cardiac myocytes
- Lens fibres
- Sensory receptors for light and sound.

In cancer, cell growth is not regulated by external signals (i.e. autonomous) and this leads to uncontrolled growth of abnormal cell.

A neoplasm can be benign or malignant.

Benign neoplasm: In benign lesions the uncontrolled growth of abnormal cells remain within the tissue of origin.



Oncogenes and Associated Human Tumours

Category	Proto-oncogene	Associated human tumours
<i>Growth factors</i>		
PDGF β chain	<i>sis</i>	Astrocytoma Osteosarcoma
Fibroblast growth factors	<i>hst-1</i> <i>Int-2</i>	Stomach cancer Bladder cancer Breast cancer Melanoma
<i>Growth factor receptors</i>		
EGF- receptor family	<i>erb-B1</i> <i>erb-B2</i>	Squamous cell ca lung Breast, ovary, lung and stomach cancer
CSF-1 receptor	<i>erb-B3</i> <i>fms</i> <i>ret</i>	Breast cancer Leukaemia MEN 2A, 2B, Familial medullary thyroid cancer
<i>Proteins involved in signal transduction</i>		
GTP- binding	<i>ras</i>	Number of cancers including lung, colon, pancreas and leukaemias
Nonreceptor tyrosine kinase	<i>abl</i>	CML, ALL
<i>Nuclear regulatory proteins</i>		
Transcriptional activators	<i>myc</i> <i>N-myc</i> <i>L-myc</i>	Burkitt's lymphoma Neuroblastoma, small cell lung cancer Small cell lung cancer
<i>Cell cycle regulators</i>		
Cyclins	<i>cyclin D</i>	Mantle cell lymphoma Breast, liver and oesophageal cancer
Cyclin dependent kinase	<i>CDK-4</i>	Glioblastoma, melanoma, sarcoma

Malignant neoplasm: The cardinal feature of malignant neoplasm is its capacity to invade tissues and leave the tissue of origin to disseminate and form metastases.

Histological distinction between benign and malignant diseases:

1. Pleomorphic cells.
2. Presence of aberrations in the nucleus.
3. Increased number of mitosis
4. Evidence of invasion.

Grade

The percentage of cells in a tumour that retain the character of the parent cell of origin is taken into account to grade the tumour. It is defined as low, moderate, or high depending on the amount of tissues that loses its normal appearance. It is useful for assessing the prognosis of many tumours, but not useful for treatment plans.

Liquid Tumours

Leukaemias and lymphomas comprise the liquid group. The treatment of liquid tumour is usually chemotherapy or radiation or both.

Solid Tumours

It comprises of tumours that arise from any solid organ or tissue. The treatment of solid tumours is usually surgery, radiation, chemotherapy or combination of these modalities.

Classification of Cancers

Type	Tissue or cell of origin	Example
Carcinoma	Endoderm or ectoderm	Adeno ca colon, small cell ca bronchus
Sarcoma	Mesoderm	Osteosarcoma, fibrosarcoma
Leukaemia	WBC	ALL
Lymphoma	Monocyte/macrophage	Hodgkin's disease

Carcinogens

Carcinogens are agents that are thought to act as cancer initiators and/or promoters.

Carcinogens and Associated Cancers

Carcinogen	Associated cancer
Alkylating agents	AML, bladder cancer
Androgens	Prostate cancer
Aromatic amines	Bladder cancer
Arsenic	Lung and skin cancer
Asbestos	Lung, pleura and peritoneal cancer
Benzene	AML
Chromium	Lung cancer
Diethyl stilbesterol	Vaginal cancer
prenatally	
EBV	Burkitt's lymphoma
Oestrogens	Endometrial and liver cancer
Ethanol	Liver, oesophageal and head and neck cancers
<i>H. pylori</i>	Gastric cancer
HBV/HCV	Liver cancer
HIV	NHL, Kaposi sarcoma, Squamous cell carcinoma
HTLV 1	Adult T cell leukaemia, lymphoma
Immunosuppressive agents (Azathioprine, cyclosporine and glucocorticoids)	NHL
Nitrogen mustard gas	Lung, head and neck and paranasal sinus carcinoma
Nickel dust	Lung, nasal sinus cancer
Phenacetin	Renal pelvic and bladder cancer
Polycyclic hydrocarbon	Lung and skin cancer
Schistosomiasis	Bladder cancer
Ultraviolet radiations	Skin cancer
Tobacco	Cancer of upper aerodigestive tract and bladder
Vinyl chloride	Angiosarcoma liver

Aetiology of Cancers

Cancer is a genetic disease. There are several other environmental factors that exert potent effects on gene. Certain viruses can cause human malignancies.

Viruses Causing Malignancy

Human Papilloma virus type 16 and 18	Cervical cancer
Hepatitis B and C viruses	Hepatoma
Epstein Barr virus	Nasopharyngeal carcinoma Lymphoma Burkitt's lymphoma
Human T cell lymphotropic virus	T cell lymphoma Leukaemia

Oesophageal Cancer

- Excessive alcohol consumption.
- Cigarette smoking.
- Ingested carcinogens like nitrates, smoked opiates, fungal toxins in pickled vegetables.

- Mucosal damage from physical agents like hot tea, chronic achalasia, radiation induced strictures.
- Host susceptibility
 - Plummer-Vinson syndrome
 - Tylosis palmaris et plantaris.
- Barrett's oesophagus
- Dietary deficiency of Molybdenum, zinc and vitamin A.
- Coeliac sprue.

Gastric Carcinoma

Dietary nitrates are converted into carcinogenic nitrites by bacteria.

Exogenous sources of nitrate converting bacteria

- Bacterially contaminated food
- *H. pylori* infection

Endogenous factors favouring growth of nitrate converting bacteria

- Decreased gastric acidity
- Prior gastric surgery
- Atrophic gastritis/pernicious anaemia

Higher incidence of gastric cancer is reported in individuals with blood group A.

Tumour Markers

Tumour marker	Cancer	Non-neoplastic conditions
<i>Oncofoetal antigens</i>		
AFP	Hepatoma, Gonadal germ cell tumour	Cirrhosis, hepatitis
CEA	Adenocarcinoma of colon, pancreas, lung, breast, ovary	Pancreatitis, hepatitis, inflammatory bowel disease, smoking
<i>Tumour associated protein</i>		
Prostate specific Ag	Prostate cancer	Prostatitis, prostatic hypertrophy
Monoclonal Ig	Myeloma	Infection, monoclonal gammopathy of uncertain significance
CA 125	Ovarian cancer, some lymphomas	Menstruation, peritonitis, pregnancy
CA 19-9	Colon, pancreas and breast ca	Pancreatitis, ulcerative colitis
CD 30	Hodgkin's disease, Anaplastic large cell lymphoma	
CD 25	Hairy cell leukaemia, Adult T cell leukaemia/lymphoma	
<i>Enzymes</i>		
Prostatic acid phosphatase	Prostate cancer	Prostatitis, prostatic hypertrophy
Neuron specific enolase	Small cell carcinoma	
LDH	Lymphoma, Ewing's sarcoma	Hepatitis, haemolytic anaemia, etc.
<i>Hormones</i>		
HCG	Gestational trophoblastic disease, Gonadal germ cell tumour	Pregnancy
Calcitonin	Medullary carcinoma thyroid	
Catecholamines	Pheochromocytoma	



Colorectal Cancer

Animal fat increases anaerobes in the gut microflora which converts normal bile acids into carcinogens. High animal fat increases cholesterol level which increases the risk for colon cancer. Dietary fibre does not alter the incidence of colorectal cancer.

Other risk factors

- Diet
 - Animal fat
- Hereditary syndromes
 - Polyposis coli
 - Nonpolyposis syndrome (Lynch syndrome)
- Inflammatory bowel disease
- Streptococcus bovis bacteraemia
- Ureterosigmoidostomy
- Tobacco use.

Small Bowel Cancers

- Higher incidence in patients with long standing regional enteritis
- Celiac sprue
- AIDS patients.

Anal Cancer

- Sexually transmitted by human Papilloma virus.
- Anal intercourse in homosexual men.
- Individual with AIDS.

Hepatocellular Carcinoma

- Chronic liver disease of any aetiology:
 - Hepatitis B and C virus
 - Alcoholic liver disease
 - Alfa 1 anti-trypsin deficiency
 - Haemochromatosis
 - Tyrosinemia
- Other risk factors include:
 - Aflatoxin B 1
 - Androgenic steroids
 - Thorium dioxide
 - Vinyl chloride.

Pancreatic Cancer

- Increasing frequency with age
 - > 50 yrs—40% risk
 - > 70 yrs—70% risk
- Obesity
- Long standing diabetes mellitus
- Chronic pancreatitis
- Cigarette smoking.

Alcohol abuse, excess coffee consumption and cholelithiasis are not risk factors for pancreatic cancer.

Head and Neck Cancer

Includes tumours of oral cavity, nasopharynx, oropharynx, hypopharynx and larynx.



Causes

- Alcohol
- Tobacco—smoking, chewing or snuffing
- Exposure to nickel
- Exposure to wood working
- Exposure to textile fibres
- HPV—oral and tonsil cancers
- EBV—nasopharyngeal cancer
- Decreased consumption of fruits and vegetables
- Consumption of salted fish.

Lung Cancer

- Leading cause of cancer death
- Age incidence is 55-65 years
- Tobacco smoking is the main cause (except adenocarcinoma).

Breast Cancer

- Germ line mutation-BRCA 1 and BRCA 2
- Strong family history
- Nulliparous women
- Early menarche
- Late menopause
- Longer length of menstrual life before first full term pregnancy
- Oral contraceptives and postmenopausal HRT
- Radiation.

Renal Cell Carcinoma

- Cigarette smoking
- Obesity
- Acquired cystic disease of kidney
- Family history
- Von Hippel-Lindau syndrome.

Bladder Cancer

- Cigarette smoking (risk persist for 10 years after stopping smoking)
- Exposure to aniline dyes, drugs—phenacetin, cyclophosphamide
- Radiation
- Schistosoma haematobium infection.

Testicular Cancer

- Age incidence 20-40 years
- Cryptorchidism (abdominal cryptorchid testis > inguinal cryptorchid testis)
- Testicular feminizing syndrome
- Klinefelter syndrome.

Ovarian Cancer

- Increasing frequency with aging
- Disordered ovarian function—infertility, nulliparity, frequent miscarriages
- Ovulation inducing drugs like clomiphene
Pregnancy, breast feeding, tubal ligation reduces the risk
- Family history of ovarian cancer
- Hereditary breast—ovarian cancer, BRCA1 and BRCA 2.

Cervical Cancer

- This is the major gynaecological cancer seen in the lower socioeconomic groups in the under-developed countries
- Women with early sexual activity or multiple sexual partners
- Cigarette smoking
- Human papilloma virus—venerally transmitted (types 16, 18, 31, 45, 51, 52 and 53).

Skin Cancer

- Persistently changing mole
- Family history of melanoma
- Personal history of prior melanoma
- More than 50 nevi of 2 mm diameter or larger size
- Excess exposure to sun or sun sensitivity
- Immunosuppression either due to diseases or therapy.

Atypical moles:

They have increased risk for malignant transformation.

Features of atypical mole

1. Various colours like black, brown, red, pink, within a single nevus
2. Irregular ill-defined borders
3. Larger size more than 6 mm in diameter
4. Number more than 100 (normal—10-40 or nil in 15% of individuals).

Nonmelanoma skin cancer (basal cell ca and squamous cell carcinoma)

- Cumulative exposure to sunlight UV B spectrum
- Male sex

- Older age
- Outdoor occupation
- Exposure to arsenic—well water or industrial source
- Exposure to tar soot or shale
- Cigarette smoking—lip cancer
- Human papilloma viruses
- UV radiations
- Immunosuppression induced by disease or drugs.

Clinical Features of Cancer

General Features

Cachexia

General ill health due to altered metabolism, anorexia, weight loss, is seen as a common manifestation of gastrointestinal cancers, cancers of lung, ovaries, testes and uncommonly in breast cancers, intracranial tumours, leukaemia and lymphoma. It is due to malnutrition, maldigestion, malabsorption, either as a result of GI cancers or pancreatic cancers or biliary tract involvement.

Cancer Anorexia and Cachexia

This syndrome consists of anorexia, distortion of taste perception, and loss of muscle mass. Tumour type is related to asthenia rather than tumour burden. Megestrol acetate 160 mg PO daily improves appetite and results in weight gain in some patients. Corticosteroids, cannabinoids and metoclopramide also improve the appetite.

Pain

It is due to:

- Nerve compression
- Distension of an organ
- Brachial plexus involvement—Ca lung or breast
- Lumbosacral plexus involvement—Ca rectum or cervix
- Paraspinal nerves—Ca pancreas
- Distension and stretching of capsule—hepatoma and secondaries liver
- Primary and metastatic lesions of bone
- Soft tissue involvement
- Pleural involvement
- Muscle spasm
- Colicky pain can be due to visceral involvement
- Periarthritis.

Nausea and Vomiting

- Gastric irritation
- Delayed gastric emptying



- Oesophageal reflux
- Intestinal obstruction
- Raised intracranial pressure
- Chemotherapy
- Radiotherapy
- Metabolic—uraemia and hypercalcaemia.

Pruritus

- Drug reaction
- Cholestatic jaundice
- Renal failure—uraemia
- Malignant disease—lymphoma, leukaemia
- Coexisting diabetes mellitus or skin disease.

Breathlessness

- Malignant pleural effusion, pericardial effusion
- Massive ascites
- Extensive lung involvement.

Extreme Anaemia

- Bleeding
- Malnutrition
- Myelosuppression.

Metabolic Syndromes

Uraemia

Glomerular Injury

This type of paraneoplastic syndrome consist of minimal change disease (Lymphoma especially Hodgkin's) and membranous glomerulonephritis (solid tumours) results in renal failure. Treatment of underlying cancer can revert the renal disease.

Hypertrophic Osteoarthropathy

It is an advanced stage of clubbing associated with polyarthrititis and periostitis involving the long bones, most often seen in non-small cell lung cancer and metastatic mediastinal nodes due to other cancers. Treat the underlying cause.

Fever

It can accompany lymphoma, renal carcinoma, and hepatic metastasis. NSAIDs are useful and carefully rule out infectious cause for fever.

Other Manifestations

- Prolonged fever
- Malaise

- Fatigue
- Hiccough.



Specific Clinical Features

Oesophageal Cancer

- Dysphagia for solid foods and later for semisolids
- Dysphagia denotes more than 60% of oesophageal circumference involvement
- Odynophagia—pain on swallowing
- Retrosternal pain, pain radiating to back, etc.

Gastric Cancer

Small superficial and surgically removable lesion is usually asymptomatic.

- Anorexia and weight loss
- Upper abdominal discomfort
- Dysphagia in lesions of cardia
- Nausea and vomiting—in lesions of pylorus
- Palpable abdominal mass indicates long standing growth
- Metastasis to intra-abdominal and supraclavicular nodes
- Metastatic nodule to ovary (Krukenberg's tumour) and periumbilical region (Sister Mary Joseph nodule)
- Malignant ascites and metastases to liver
- Occult blood in stools
- Iron deficiency anaemia
- Migratory thrombophlebitis
- Haemolytic anaemia
- Acanthosis nigricans denotes gastric adenocarcinoma.

Colorectal Cancer

- Unexplained iron deficiency anaemia leading to fatigue, palpitation, and at times angina
- Occult blood in stools—positive or negative owing to intermittent bleed
- Altered bowel habits (transverse and descending colon growth)
- Abdominal cramping, tenesmus (rectosigmoid region) and occasional obstruction
- Haematochezia.

Small Bowel Cancer

- Periumbilical pain made worse by eating.
- Weight loss
- Vomiting due to intestinal obstruction (occasional).

Anal Cancer

- Sensation of perianal mass
- Pruritus
- Pain
- Bleeding.

Hepatocellular Carcinoma

- Right upper quadrant mass with pain
- Friction rub or bruit over the mass
- Haemorrhagic ascites 20% of cases
- Jaundice is not common
- Elevated alkaline phosphatase, serum α fetoprotein (AFP) > 500 $\mu\text{g}/\text{litre}$.
- Paraneoplastic syndromes consisting of erythrocytosis, hypercalcaemia, hypercholesterolaemia, hypoglycaemia, dysfibrinogenaemia.

Pancreatic Cancer

- Head—70%
- Body—20%
- Tail—10%.
- Ductal adenocarcinoma 90%
- Islet cell tumour 10%
- Epigastric pain radiating to back
- Weight loss (pain and weight loss in 75% cases)
- Jaundice is seen in lesions of pancreatic head only
- Painless jaundice is a feature of carcinoma of bile duct
- Enlarged palpable gallbladder—Courvoisier's sign
- Venous thrombosis and migratory thrombophlebitis—Trousseau's syndrome
- Tumour compressing portal venous system leading to splenomegaly and GIT bleeding
- Glucose intolerance is infrequent.

Head and Neck Cancer

- Nonhealing ulcers of oral cavity
- Alterations in speech—tumours of tongue and oropharynx
- Persistent hoarseness of voice—laryngeal cancer
- Serous otitis media due to obstruction of Eustachian tube—cancer of nasopharynx
- Nasal obstruction or epistaxis
- Local pain, otalgia, trismus
- Dysphagia/odynophagia
- Airway obstruction
- Neuropathies of cranial nerves
- Unilateral/bilateral cervical lymphadenopathy
- Leukoplakia/erythroplakia are premalignant lesions.

Lung Cancer

- Persistent cough/haemoptysis
- Localised monophonic wheeze/stridor/dyspnoea
- Unresolved/recurrent pneumonia of the same segment
- Lung abscess
- Tracheal/oesophageal obstruction due to metastatic lymph nodes
- Involvement of recurrent laryngeal nerve—hoarseness of voice
- Phrenic nerve—elevated hemidiaphragm
- Cervical sympathetic chain—Horner's syndrome
- C8T1 and T2 spinal nerve—Pancoast tumour
- Pleural involvement with pain or haemorrhagic pleural effusion
- Superior vena caval syndrome
- Pericarditis/effusion
- Cardiac arrhythmias, failure
- Brain metastasis with neurological deficits
- Liver metastasis with jaundice, altered liver functions
- Bone metastasis with pain and fracture
- Paraneoplastic syndromes
- Clubbing/hypertrophic pulmonary osteoarthropathy
- Neurologic/myopathic syndromes
- Migratory thrombophlebitis
- Nonbacterial thrombotic (marantic) endocarditis. Rare manifestations include dermatomyositis, acanthosis nigricans, glomerulonephritis.

Breast Cancer

- Palpable mass—hard, irregular, painless, tethered, or fixed
- Retraction of skin over the breast or the nipple
- Nipple discharge
- Enlargement of regional lymph nodes
- One per cent risk of false negativity (triple negativity—benign feeling lump, negative mammogram, negative fine needle aspiration).

Renal Cell Carcinoma

- Classical triad
 1. Haematuria
 2. Flank pain
 3. Palpable flank mass
- Anaemia, fever, weight loss
- Raised ESR
- Abnormal liver function
- Hypercalcaemia
- Erythrocytosis (3%)
- Neuromyopathy
- Amyloidosis.



Bladder Cancer

- Gross haematuria
- Irritative symptoms—increased frequency, dysuria, urgency.

Prostate Cancer

Symptoms of outlet obstruction

- Hesitancy
- Diminished stream
- Intermittent voiding
- Incomplete emptying
- Post void leakage.

Other symptoms

- Symptoms of increased frequency nocturia, dysuria and urgency
- Urinary retention
- Microscopic haematuria
- Haematospermia
- Erectile dysfunction
- Pain secondary to bone metastasis
- Spinal cord compression.

Testicular Cancer

- Painless testicular mass
- Persistent painful testicular swelling
- Back pain due to retroperitoneal metastasis
- Dyspnoea due to pulmonary metastasis.

Ovarian Cancer

- Mostly asymptomatic
- Increased urinary frequency
Constipation
- Acute abdominal pain due to torsion mass
- Solid irregular and fixed adnexial mass.

Cervix Cancer

- Post coital spotting
- Abnormal menstrual bleeding
- Inter menstrual bleeding
- Yellowish vaginal discharge
- Lumbosacral back pain
- Urinary symptoms.



Investigations

Oesophageal Cancer

- Contrast radiographs—Barium swallow with screening
- Oesophagoscopy and biopsy
- Cytologic examination of tumour brushings.

Gastric Cancer

- Double contrast radiographic examination
- Gastroscopy and biopsy
- Brush cytology.

Colorectal Cancer

- Fecal haemocult test
- Sigmoidoscopy/colonoscopy
- Double contrast—air barium enema.

Small Bowel Cancer

- Barium study by infusing barium through a nasogastric tube placed in the duodenum
- Endoscopy and biopsy
- For lymphomas
 - Peripheral blood smear
 - Bone marrow aspiration
 - Chest X-ray
 - CT thorax and abdomen.
- Surgical exploration and resection.

Anal Cancer

- Digital rectal examination
- Proctoscopy.

Hepatocellular Carcinoma

- AFP levels more than 500 µg/litre (in the absence of obvious GIT tumour).
- Elevated serum alkaline phosphatase
- USG abdomen
- CT/MRI abdomen
- Hepatic artery angiography
- Technetium scan
- USG/CT guided liver biopsy
- Ascitic fluid cytology
- Laparoscopy/minilaparotomy.

Pancreatic Cancer

- Carcino embryonic antigen and CA-19-9
- USG
- CT abdomen (detection rate 85%)
- Endoscopic retrograde cholangiopancreatography (ERCP)
- Endoscopic USG (EUS)
- MRI and PET—no better than CT
- Spiral CT with contrast
- Selective angiography.

Head and Neck Cancer

- Laryngoscopy, esophagoscopy, bronchoscopy
- Biopsy of all visible lesions

- CT head and neck
- Chest X-ray and bone scan for distant metastasis
- Lymph node biopsy.

Lung Cancer

- Sputum cytology
- Chest X-ray PA and lateral view
- CT thorax
- Spiral CT
- Bronchoscopy—brush cytology and biopsy
- Fine needle aspiration under CT guidance
- Biopsy of enlarged lymph nodes
- Pleural fluid cytology.

Breast Cancer

- Diagnostic mammography
- Fine needle aspiration
- USG
- MRI
- Sestamibi imaging
- Excision biopsy
- Stereotactic core biopsy for nonpalpable lesions.

Renal Cell Carcinoma

- Urine analysis and urine cytology
- CT abdomen and pelvis
- Chest X-ray
- USG
- MRI for lesions involving IVC.

Bladder Cancer

- Urine cytology
- Cystoscopy and biopsy
- Intravenous pyelogram (IVP)
- CT and MRI
- USG
- Chest X-ray
- Radionuclide scan for skeletal metastasis.

Prostate Cancer

- Abnormal per rectal examination
- Prostate specific antigen > 10 nanogm/ml (5-10 nanogm/ml is borderline positive)
- Transrectal USG and biopsy
- CT and MRI.

Testicular Cancer

- Serum tumour markers—AFP and HCG
- USG testis
- Chest X-ray
- CT abdomen and pelvis.

Ovarian Cancer

- Serum level of tumour marker—CA 125
- Transvaginal USG
- Doppler flow imaging coupled with transvaginal USG
- Chest X-ray, CT pelvis and abdomen for staging.

Cervix Cancer

- PAP smear
- Colposcopy and biopsy
- Cone biopsy for endocervical tumour
- Chest X-ray, IVP.

Diagnosis

Tumour tissue biopsy is essential to confirm the diagnosis. Tumours may be heterogeneous in appearance and in such cases more tissue is required for making the correct diagnosis. The biopsy technique that involves cutting into the tumour carry with them the risk of facilitating spread of tumour. There are several types of biopsy procedures.

1. Excisional biopsy
2. Incisional biopsy
3. Endoscopic core needle biopsy
4. Fine needle aspiration.

Immunological detection of proteins is more effective in fresh frozen tissue rather than in formalin fixed tissues.

Staging

Staging defines the extent of dissemination of tumour by extensive radiographic and other imaging procedures and at times by surgical procedures. It is very essential to select the correct mode of management and also to assess the prognosis.

TNM Classification

TNM classification is the internationally recognized staging system.



Investigations to Define TNM Status

Tumour:

- Palpation
- Inspection including endoscopy
- Radiology
- Cytology/aspiration/biopsy.



Node

- Palpation
- Aspiration
- Biopsy
- Radiology.

Metastasis

- Biochemical screening
- Radionuclide scan
- USG liver
- Radiology
- Laparoscopy
- Laparotomy.

TNM Classification

- T** - Extent of primary tumour
- N** - Extent of regional lymph node involvement
- M** - Presence or absence of metastasis

Extent of disease:

- T0 } Excised tumour
- T1 } increasing primary tumour size
- T2 }
- T3 }

Extent of involvement of nodes:

- N1 } increasing involvement
- N2 }
- N3 }

Presence of metastasis

- M0 not present
- M1 present.

Site of Metastatic Involvement—%

Primary site	Liver	Lungs	Bone	Brain
Lung	30-50	30	30-50	15-30
Breast	60	60	50-85	15-25
Thyroid	60	65	40	1
Liver	NA	20	10	0
Pancreas	50-70	25-40	5-10	1-5
Stomach	35-50	20-30	5-10	1-5
Colorectal	70	25-40	5-10	1
Renal	35-40	50-75	30-50	5-10
Ovary	10 -15	10	5	1
Prostate	10- 15	10-50	50-75	2

Performance Status

Various scales are used to assess the functional capability of the patient. They are useful in assessing the prognosis and also the efficacy and toxicity of management. Fully active patients are likely to fare well and the bed-ridden patients are likely to fare worse.

Karnofsky Performance Index

Performance status	Functional capability of the patients
100	Normal
90	Able to carry on normal activity; Minor signs and symptoms of disease
80	Normal activity with effort; Some signs or symptoms of disease
70	Cares for self; Unable to carry on normal activity
60	Requires occasional assistance for care of self;
50	Requires considerable assistance and frequent medical care
40	Disabled; Requires special care and assistance
30	Severely disabled; Hospitalisation is indicated
20	Very sick; Active supportive treatment is necessary
10	Moribund; Fatal processes progressing rapidly
0	Dead

Eastern Cooperative Oncology Group Performance Status Scale

Performance status	Functional capability of the patients
0	Fully active, able to carry on all usual activity without restriction and without the aid of analgesics
1	Restricted in strenuous activity, but ambulatory or fully active but only with the aid of analgesics
2	Ambulatory and capable of all self-care but unable to work, moving about for more than 50% of the waking hours
3	Capable of only limited self-care, confined to bed or chair for more than 50% of waking hours
4	Completely disabled, unable to carry out any self-care and totally confined

Cancer Screening

Screening recommendations for asymptomatic normal risk subjects.



Complications

Infections in Cancer Patients

Infections in cancer patients increase morbidity and mortality. Alterations in the immune system either as a result of the disease *per se* or as a result of chemo/ radiotherapy predisposes the individual to intercurrent infections.

Cancer Screening

Test of procedure	American cancer society recommendations
Sigmoidoscopy	> 50 years, every 3-5 years
Fecal occult blood	> 50 years, every year
Digital rectal examination	> 40 years, every year
Prostate specific antigen	> 50 years, every year
PAP test	From age 18 yearly thrice, and then at physicians discretion
Pelvic examination	18-40 years, every 1-3 years with PAP test
Endometrial tissue sampling	> 40 years, every year At menopause, if obese or a history of unopposed oestrogen use
Breast self-examination	> 20 years, monthly
Breast clinical examination	20-40 years, every 3 years
Mammography	> 40 years, yearly
Complete skin examination	> 40 years, every year 20-40 years every 3 months

Gastrointestinal Tract Infection

Mouth ulcerations

- *Streptococcus viridans*
- Virus—HSV (Acyclovir)
- Fungal thrush—*Candida albicans* (Fluconazole)

Oesophageal infections

HSV and candidiasis

Hepatosplenic involvement

Chronic disseminated candidiasis (Amphotericin B and Fluconazole)

Alterations in Normal Barriers of Infection in Malignancy

Type of cancer	Disease	Underlying defense/immune abnormality
Head and neck, squamous cell ca	Cellulitis	Disruption of physical barrier (skin)
Renal, ovarian, biliary, metastatic ca	Bacteremia UTI	Occlusion of normal patent orifices
Breast cancer surgery	Cellulitis	Disruption of lymphatic
Hodgkin's disease, ITP, leukaemia	Overwhelming sepsis	Splenectomy
Hairy cell leukaemia, AML, ALL	Bacteremia	Phagocytic abnormality of granulocytes
CLL	Infection with encapsulated organism, sinusitis, pneumonia	Humoral immunity
Hodgkin's disease T cell lymphoma, leukaemia	Infections with intracellular bacteria, fungi, parasites	Cellular immunity

Typhlitis

Neutropaenic necrotising colitis, illeocaecal syndrome; all due to aerobic gram-negative bacilli (broad spectrum bactericidal agent).

Clostridium difficile induced diarrhoeas

Infections and Cancer

Cancer	Underlying immune abnormality	Organisms causing infection
Multiple myeloma	Hypogammaglobulinaemia	<i>Streptococcus pneumoniae</i> , <i>Haemophilus influenzae</i> , <i>Neisseria meningitidis</i>
Chronic lymphocytic leukaemia	Hypogammaglobulinaemia	<i>S. pneumoniae</i> , <i>H. influenzae</i> , <i>N. meningitidis</i>
Acute myelocytic or lymphocytic leukaemia	Granulocytopenia, skin and mucous-membrane lesions	Extracellular gram-positive and gram-negative bacteria, fungi
Hodgkin's disease	Abnormal T cell function	Intracellular pathogens (<i>Mycobacterium tuberculosis</i> , <i>Listeria</i> , <i>Salmonella</i> , <i>Cryptococcus</i> , <i>Mycobacterium avium</i>)
Non-Hodgkin's lymphoma and acute lymphocytic leukaemia	Glucocorticoid chemotherapy, T and B cell dysfunction	<i>Pneumocystis carinii</i>
Colon and rectal tumours	Local abnormalities	<i>Streptococcus bovis</i> (bacteraemia)
Hairy cell leukaemia	Abnormal T cell function	Intracellular pathogens (<i>M. tuberculosis</i> , <i>Listeria</i> , <i>Cryptococcus</i> , <i>M. avium</i>)



Central Nervous System Infections

<i>Meningitis</i>	<i>S. pneumoniae</i> <i>H. influenzae</i> <i>N. meningitidis</i> Cryptococcal and Listerial infections
<i>Encephalitis</i>	Varicella zoster virus
<i>Brain abscess</i>	Cryptococcus Nocardia Aspergillus.

Progressive multifocal leucoencephalopathy

Cardiovascular Infections

Intravenous catheters

- Bacterial endocarditis
- Valve damage

Severe bacteraemia

Nonbacterial thrombotic endocarditis

Endocrine Infections

Candida infection of thyroid
CMV adrenalitis with or without adrenal insufficiency

Renal and Ureteral Infections

Fungal balls/candiduria or persistent funguria-
Aspergillus/candida

BK virus induced cystitis



Treatment

Antibacterial therapy

- Penicillin group + Aminoglycoside
- Or
- Single 3rd generation Cephalosporin

Antifungal therapy

Amphotericin B/Amphotericin B deoxycholate complex
P. Carinii infection—Trimethoprim, Sulfamethoxazole

Cytokines

- Granulocyte colony stimulating factor
- Granulocyte—Macrophage colony stimulating factor.

They are indicated for severe and prolonged neutropenia.

Infections of neutropaenic patients

Granulocyte transfusion is reserved for patients unresponsive to antibiotics.

Vaccination of Cancer Patients

They respond less well to vaccines than normal host.
Live bacterial/viral vaccines should not be given.
Vaccination should not be given concurrently with cytotoxic chemotherapy.

Paraneoplastic Syndromes

Endocrine Syndromes

Cancer cells produce peptide or protein hormones that cause most hormonal syndromes.

Hypercalcaemia



Clinical Features

Calcium level more than 2.6 mmol/L (11.7 mg/dl)

- Malaise, fatigue, confusion, anorexia
- Bone pain
- Polyuria

Pulmonary Infections: Differential Diagnosis of Chest Infiltrates in Immunocompromised Patients

Cause of Pneumonia		
Infiltrate	Infectious	Noninfectious
Localised	Common bacterial pulmonary pathogens, Legionella, mycobacteria	Local haemorrhage or embolism, tumour
Nodular	Fungi (e.g. Aspergillus or Mucor), Nocardia	Recurrent tumour
Diffuse	Viruses (especially CMV), Chlamydia, Pneumocystis carinii, Toxoplasma gondii, mycobacteria	Congestive heart failure, radiation pneumonitis, drug-induced lung injury, diffuse alveolar haemorrhage (described after BMT) CMV, cytomegalovirus; BMT, bone marrow transplantation.

Vaccination of Cancer Patients Receiving Chemotherapy

Vaccine	Use in Indicated Patients		
	Intensive chemotherapy	Hodgkin's disease	Bone marrow transplantation
Diphtheria-tetanus (diphtheria, pertussis, tetanus; DPT) for children < 7 years old	Primary series and boosters as necessary	No special recommendation	12 and 24 months after transplantation
Poliomyelitis	Complete primary series and boosters	No special recommendation	12 and 24 months after transplantation
<i>Haemophilus influenzae</i> type b	Primary series and booster for children	Immunisation before treatment and booster 3 months afterward	12 and 24 months after transplantation
23-Valent pneumococcal	Every 5 years	Immunisation before treatment and booster 3 months afterward	12 and 24 months after transplantation
4-Valent meningococcal	Every 5 years	Immunisation before treatment and booster 3 months afterward	12 and 24 months after transplantation
Influenza	Seasonal immunisation	Seasonal immunisation	Seasonal immunisation
Measles/mumps/rubella	Contraindicated	Contraindicated	After 24 months in patients without graft-versus-host disease
Varicella-zoster virus	Contraindicated	Contraindicated	Contraindicated

- Polydipsia
- Weakness
- Nausea, vomiting, constipation.

Calcium level more than 3.5 mmol/L (15.75 mg/dl)

- Severe confusion,
- Lethargy, coma and death.

Local osteolytic hypercalcaemia (LOH) is responsible for hypercalcaemia in patients with breast cancer, Myeloma, lymphoma and leukaemia.

Management

Hydrate—2-4 litres of normal saline IV/day

Bisphosphonates—30 mg in 300 ml of normal saline over 3 hrs (max dose 90 mg/course)

Loop diuretics

LOH—Glucocorticoids

Severe hypercalcaemia—(>14 mg%) Calcitonin 4-8 U/kg IM/SC every 12 hours

Refractory cases—Plicamycin and Gallium nitrate may be added.

Hyponatraemia—SIADH

Serum sodium level < 130 mmol/L

Symptoms of mild hyponatraemia (120-130 mmol/L)

- Loss of concentration
- Anorexia, nausea, vomiting
- Fatigue, weakness, headache.

Common Paraneoplastic Endocrine Syndromes

Syndrome	Proteins	Tumours typically associated with syndrome
Hypercalcaemia of malignancy	Parathyroid hormone-related peptide	Non-small cell lung cancer Breast cancer Renal cell carcinoma
	Parathyroid hormone	Head and neck cancer Bladder cancer Myeloma
Syndrome of inappropriate antidiuretic hormone secretion (SIADH)	Arginine vasopressin (AVP)	Small cell lung cancer Head and neck cancer
	Atrial natriuretic peptide	Non-small cell lung cancer
Cushing's syndrome	Adrenocorticotrophic hormone (ACTH) Corticotropin-releasing hormone (CRH)	Small cell lung cancer Carcinoid tumours
Acromegaly	Growth hormone-releasing hormone (GHRH) Growth hormone (GH)	Carcinoid tumours Small cell lung cancer Pancreatic islet cell tumours
Gynaecomastia	Human chorionic gonadotropin (hCG)	Testicular cancer Lung cancer Carcinoid tumours of the lung and gastrointestinal tract
Non-islet cell tumour hypoglycaemia	Insulin-like growth factor-2	Sarcomas



Severe hyponatraemia (<120 mmol/L)

- Confusion, lethargy
- Coma, seizures, death.

Management

- Fluid restriction—500 ml/day for 7 days
- Oral demeclocycline—600-1200 mg/day
- Other agent—phenytoin and lithium
- Normal saline hydration with loop diuretic for profound hyponatraemia
Refractory cases—3% saline via central line with frusemide.

Ectopic ACTH Syndrome (Cushing Syndrome)



Clinical Features

Weakness, hypertension, hyperglycaemia
In slow growing tumours—central obesity, hirsutism.



Management

Treat the underlying cancer
Inhibition of steroidogenesis
Ketoconazole 400-1200 mg/day
Metyrapone 1-4 g/day
Refractory cases adrenalectomy.

Ectopic Acromegaly



Clinical Features

Increasing size of hands and feet
Facial disfigurement, hypertension, diabetes mellitus
Muscle weakness, amenorrhoea-galactorrhoea, impotence.



Management

Treat the underlying cancer
Octreotide 100-250 µg every 8 hrs.

Gynaecomastia

Treat the underlying cancer
It resolves in 75% of cases.

Nonislet Cell Tumour Hypoglycaemia



Clinical Features

Headache, fatigue, confusion, seizures



Management

Frequent oral feeding
Constant IV glucose

Haematologic Syndromes

Paraneoplastic Haematologic Syndromes

Syndrome	Proteins	Cancers typically associated with syndrome
Erythrocytosis	Erythropoietin	Renal cancers Hepatocarcinoma Cerebellar hemangioblastomas
Granulocytosis	G-CSF GM-CSF IL-6	Lung cancer Gastrointestinal cancer Ovarian cancer Genitourinary cancer
Thrombocytosis	IL-6	Lung cancer Gastrointestinal cancer Breast cancer Ovarian cancer Lymphoma
Eosinophilia	IL-5	Lymphoma Leukaemia Lung cancer
Thrombophlebitis	Unknown	Lung cancer Pancreatic cancer Gastrointestinal cancer Breast cancer Genitourinary cancer Ovarian cancer Prostate cancer Lymphoma



Management

Erythrocytosis
Treat the cancer
Periodic phlebotomy

Granulocytosis > 8000/µL
Treat the underlying cancer.

Thrombocytosis > 400,000/µL
This indicates advanced stage cancer and poor prognosis.
Does not require treatment.

Eosinophilia > 5000/µL
Dyspnoea due to pulmonary infiltrates
Oral/inhaled glucocorticoids
Treat the underlying cancer.

Thrombophlebitis

Leads to deep vein thrombosis/pulmonary embolism

- Low molecular weight heparin- 5 days
- Coumarin – for 3-6 months
- Keep the INR between 2-3.

Neurologic Syndromes

See Table on page 739.

NB: POEMS—polyneuropathy, organomegaly, endocrinopathy, myeloma and skin pigmentation. CIDP—Chronic inflammatory demyelinating polyneuropathy.

Oncologic Emergencies**Superior Vena Caval Obstruction****Causes**

- Lung cancer
- Lymphoma
- Mediastinal cancers/metastasis.

**Clinical Features**

- Swelling of face, neck, upper extremities and chest
- Dilated superficial veins over the chest
- Chest pain, cough and dyspnoea, haemoptysis
- Headache, nasal congestion, epistaxis
- In severe obstruction—proptosis, glossal and laryngeal oedema.

**Investigations**

- Sputum cytology
- Chest X-ray and thorax.

**Management**

- Dexamethasone 4 mg 6th hourly orally
- Radiation for non-small cell lung cancer and metastatic tumours
- Chemotherapy for small cell lung cancer and lymphoma
- Maintain airway
- Surgery is useful in benign lesions.

Increased Intracranial Pressure (Brain Metastasis)**Causes**

Metastatic brain tumour from lung—breast cancer.

**Clinical Features**

Headache, nausea, vomiting
Papilloedema
Behavioural changes, seizures, focal neurological deficits.

**Investigations**

CT and MRI with contrast.

**Management**

Dexamethasone 4-8 mg IV or orally 6th hourly
Whole brain irradiation
For solitary lesions—surgery followed by radiotherapy
Intubation—hyperventilation-mannitol infusion (maintain PCO₂ at 25-30 mmHg)
Stereotactic radiosurgery for inaccessible lesions.

Meningeal Carcinomatosis

Involvement of leptomeninges either by primary or metastatic tumour.

**Causes**

Lung cancer
Breast cancer
Melanoma
Acute leukaemia
Lymphoma.

**Clinical Features**

Headache, vomiting, gait abnormalities
Cranial nerve palsies, mental changes
Seizures, limb weakness, decreased deep tendon reflexes.



Neurologic Paraneoplastic Syndromes

<i>Syndrome</i>	<i>Features</i>	<i>Antibody target</i>	<i>Neoplasm/Percentage</i>
Brain			
Limbic encephalitis	Onset: subacute Confusion Memory loss Temporal lobe seizures	Hu	SCLC, testicular cancer, breast, colon, bladder, lymphoma
Brainstem encephalitis	Vertigo Cerebellar: ataxia, nystagmus Ocular: diplopia, gaze palsies	Hu	SCLC
Cerebellar degeneration	Cerebellar: ataxia, dysarthria	Yo Tr Glutamate receptors	Ovary, uterus, SCLC, Hodgkin's lymphoma
Opsoclonus/myoclonus	Involuntary eye movements: rapid, random directions Ataxia Encephalopathy	Ri (NOVA) Hu Neurofilament	Neuroblastoma, lung, breast
Spinal cord			
Necrotizing myelopathy	Weakness: paraplegia or quadriplegia Sensory loss: spinal level Urinary incontinence	Not known	SCLC, lymphoma
Peripheral nerve			
Neuronopathies			
Sensory neuropathy	Onset: subacute Sensory loss; diffuse, asymmetric, numbness/paresthesias, dysesthesia/pain Sensory ataxia: pseudoathetosis ± encephalomyelitis	Hu	SCLC (90% of cases), breast, ovary, prostate
Motor neuropathy	Onset: subacute Weakness: arms > legs Usually asymmetric	Not known	Lymphoma
Axonal neuropathies			
Sensorimotor neuropathy	Distal motor and sensory loss Most common paraneoplastic neuropathy, especially with >15% weight loss Axonal neuropathy	None	Many neoplasms
Mononeuritis multiplex	Weakness and/or sensory loss in the distribution of multiple nerves Onset: acute to subacute	Not known	Cryoglobulinaemia, leukaemia, lymphoma
Neuromyotonia (Isaacs)	Weakness: distal and proximal Stiffness Fasciculations	Voltage-gated potassium channels	Thymoma
Amyloid neuropathy	Distal symmetric axonal loss: small > large Autonomic symptoms prominent	Not known	Multiple myeloma
Autonomic neuropathies			
Enteric neuropathy	Gastroparesis Intestinal pseudo-obstruction Esophageal achalasia Dysphagia	Hu	Thymoma, SCLC
Demyelinating neuropathies			
Anti-MAG	Sensory > motor Distal, symmetric Gait disorder Tremor	Myelin-associated glycoprotein (MAG)	MGUS, IgM M-protein in 85%

Contd...



Contd...

Syndrome	Features	Antibody target	Neoplasm/Percentage
Multifocal motor neuropathy	Slowly progressive NCV: Long distal latencies, Conduction block uncommon Slowly progressive Motor Distal > proximal Asymmetric NCV: Motor conduction block Motor axon loss (late)	G _{M1} ganglioside	MGUS, IgM M-protein in 20%
Anti-sulfatide	Slowly progressive Sensory > motor Distal, symmetric Demyelinating or axonal	Sulfatide	MGUS, IgM M-protein in 90% with demyelinating neuropathy
POEMS	Sensorimotor neuropathy Symmetric Mixed demyelinating and axonal	Not known	Multiple myeloma, IgG or IgA M-protein in 90%
CIDP	Chronic or relapsing Motor > sensory Distal and proximal weakness Usually symmetric NCV: Conduction block, slow sensory and motor conduction velocities	β-Tubulin in 20%	MGUS, IgM or IgG M-protein in 15%, lymphoma
Neuromuscular junction			
LEMS	Weakness: proximal and distal Ocular: ptosis May improve with exercise Dry mouth Rapid repetitive stimulation: increment	Voltage-gated P/Q calcium channels	SCLC in 60% of cases, especially older and smoking history
Myasthenia gravis	Weakness Cranial: ocular, face, bulbar Respiratory, limbs, trunk Fatigue Slow repetitive stimulation: decrement	Nicotinic acetylcholine receptor	Thymoma in 10%, especially >30 years
Muscle			
Necrotizing myopathy	Males > 40 Rapid-onset weakness Necrosis on muscle biopsy May improve with treatment of cancer	Not known	Lung, breast, alimentary tract
Dermatomyositis	Females > 40 Proximal muscle weakness Skin rash	Not known	Ovarian, nasopharyngeal
Type II atrophy	Especially with weight loss > 15% Wasting > weakness	Not known	Many neoplasms
Myopathy with anti-decorin antibodies	> 50 years of age Proximal symmetric weakness Mildly elevated creatine kinase	Decorin	Waldenström's macroglobulinaemia, IgM M-protein
Rippling muscle disease	Cramps induced by touching muscle Muscle waves induced by percussion Electrically silent	Not known	Thymoma
Scleromyxoedema	Skin papules Raynaud's phenomenon Proximal muscle weakness High creatine kinase Myopathic electromyography	Not known	MGUS, IgG or IgA M-protein



Investigations

CT/MRI before LP to rule out parenchymal metastasis
 LP—CSF cytology, elevated protein level
 MRI—Hydrocephalus/smooth or nodular enhancement of meninges.



Treatment

Intrathecal chemotherapy (methotrexate, cytarabine, thiotepea)
 Local radiation therapy
 IV arabinoside for meningeal lymphoma.

Intracerebral Leucocytostasis (Ball's Disease)

Potential fatal complication of acute leukaemia
 More common with myelogenous leukaemia
 It occurs when the peripheral blast cell count is more than 1 lakh/ μ L
 Brain invasion with blast cell through endothelial damage results in haemorrhage.



Clinical Features

- Visual disturbance
- Ataxia, stupor
- Dizziness
- Coma, death.



Management

Whole brain irradiation
 Aggressive antileukaemic therapy.

Seizures



Causes

Primary/metastatic tumour
 Metabolic disturbance
 Radiation injury
 Chemotherapy related encephalopathy
 CNS infections/cerebral infarction
 Drugs—etoposide, busulphan, chlorambucil.



Management

Anticonvulsant therapy with phenytoin.

Spinal Cord Compression

Hematogenous spread of cancer to vertebral bodies.



Causes

- Lung cancer
- Breast cancer
- Prostate cancers
- Multiple myeloma.

Site of Lesion

Vertebral column more involved than other bones

- Thoracic spine—70%
- Lumbosacral spine—20%
- Cervical spine—10%



Clinical Features

- Localised back pain and tenderness
- Pain precedes neurological deficits
- Pain aggravated by coughing and sneezing
- Radicular pain—unilateral or bilateral
- Loss of bowel and bladder control
- Pain worsens when the patient is supine (in disc lesions pain is relieved in supine positions)
- Signs of cord compression.



Investigations

X-ray of spine

Erosion of pedicles (winking owl sign)
 Increased interpedicular distance
 Vertebral destruction and collapse.

MRI spine

Gadolinium enhanced MRI for intramedullary lesions
 In case of poor MR images, myelography or CT with myelography.



Management

High dose dexamethasone—8 mg 6th hourly
 Radiation therapy
 Surgery and chemotherapy.

Malignant Effusions

Malignant Pericardial Effusion



Causes

Lung cancer
 Breast cancer

Leukaemias and lymphoma
Radiation
Drug induced.

Radiation

1. Acute inflammatory effusive pericarditis (within months)
2. Chronic effusive pericarditis with thickened pericardium (up to 20 years after irradiation).



Clinical Features

Dyspnoea, cough, chest pain
Distended jugular veins
Hepatomegaly
Peripheral oedema
Paradoxical pulse and pulsus alternans
Friction rub and cardiac tamponade.



Management

Cardiac tamponade warrants immediate pericardiocentesis
Uncontrolled disease—pericardiocentesis with sclerosis
Sclerosis—30–60 mg Bleomycin instillation and withdrawal after 10 mts
Recurrent accumulation—subxyphoid pericardiectomy

Malignant Pleural Effusion

Caused by invasion by tumour or obstruction to lymphatic drainage.



Management

Drainage of pleural fluid followed by instillation of sclerosing agents
Resistant effusion—pleurectomy.

Malignant Ascites



Cause

Peritoneal carcinomatosis
Controlled by systemic chemotherapy and rarely intraperitoneal instillation of chemotherapeutic agent.

Airway Obstruction



Causes

Intraluminal tumour growth
Extrinsic compression.



Management

Obstruction proximal to larynx—tracheostomy is life saving
Distal obstructions—laser treatment, photodynamic therapy and stenting
Emergency radiotherapy and glucocorticoids may open the airway.

Haemoptysis



Causes

Twenty per cent of patients with lung cancer
Metastasis from breast, colon, kidney, melanoma and carcinoid tumours.



Management

Blood transfusion
Oxygen
Emergency bronchoscopy
Surgery/Nd: YAG laser therapy
Bronchial artery embolisation.

Intestinal Obstruction



Causes

Colorectal and ovarian cancers
Metastatic lesions of lung and breast cancers and melanoma.



Clinical Features

- Colicky pain
- Vomiting
- Constipation
- Abdominal pain
- Visible peristalsis
- High pitched bowel sounds
- Palpable tumour masses.



Investigations

- Plain X-ray abdomen erect:
 - Multiple air fluid level
 - Dilation of small or large bowel
- USG abdomen.

Prognosis

- Overall prognosis is poor
- Acute caecal dilation is a surgical emergency
- Median survival 3-4 months.



Management

- Nasogastric decompression
- Antispasmodics
- Surgery
- Self-expanding metal stents.

Urinary Obstruction



Causes

- Prostate/cervix cancer
- Radiation therapy for pelvic tumours.



Clinical Features

- Outlet obstruction results in bilateral hydronephrosis and renal failure
- Flank pain dysuria
- Proteinuria, haematuria
- Polyuria, anuria
- Rising urea and creatinine value.



Investigations

- Renal USG
- CT abdomen to identify retroperitoneal mass/lymphadenopathy.



Management

- Stents for ureteral obstructions
- Percutaneous nephrostomy for hydronephrosis
- Suprapubic cystostomy for bladder outlet obstruction.

Biliary Obstruction



Causes

- Pancreatic cancer
- Bile duct carcinoma
- Hepatoma
- Metastasis from gastric, colonic, breast and lung cancers.



Clinical Features

- High coloured/light coloured stools
- Jaundice, pruritus
- Malabsorption leading to weight loss.



Investigations

- USG/CT abdomen
- Percutaneous transhepatic/Endoscopic retrograde cholangiopancreatography
- MRCP (Figs 11.1A to E).



Management

- Stenting/surgical bypass
- Radiotherapy/chemotherapy.

Other Emergencies

- Lactic acidosis
- Hypoglycaemia
- Adrenal insufficiency
- Bone metastasis and spontaneous fractures
- Minimal change/membranous glomerulonephritis.

Metastatic Cancer of Unknown Primary Site

Biologic Behaviour

- Primary becomes apparent during the course of illness in 20%
- Primary diagnosed at autopsy in 60%
- Primary not traced even at autopsy in 20%
- Median survival 6-12 months.

Clinical Evaluation

Suggested clinical evaluation of patients with metastatic cancer of unknown primary site

- History: Smoking history, asbestos exposure, abdominal pain
- Physical examination: Lymph nodes, thyroid, skin;
- Men: Prostate

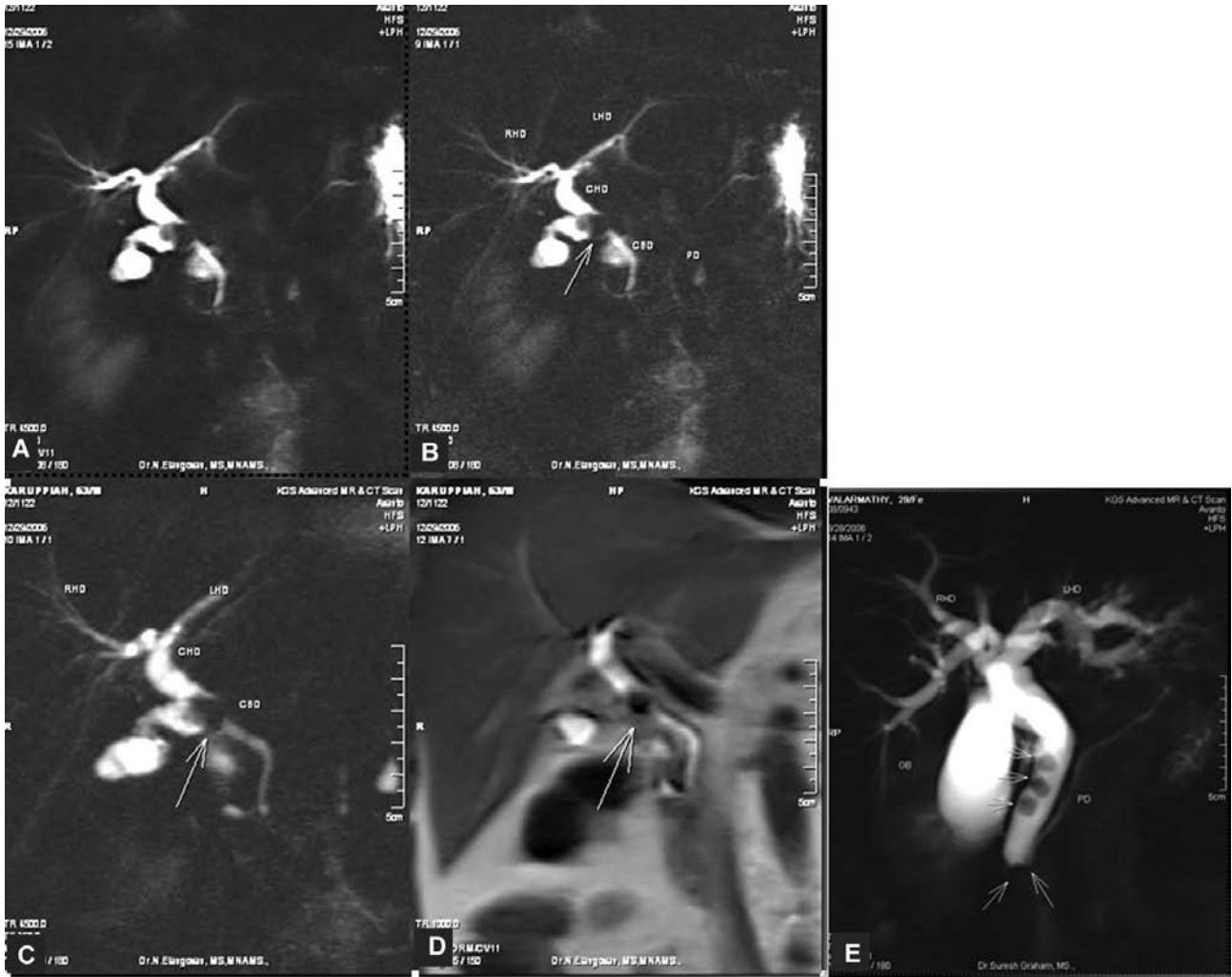

Figs 11.1A to E: (A) MRCP filling defects seen in distal CBD (calculi) with dilated proximal CBD, hepatic ducts (B to E) calculus in cystic duct

- Women: Breasts, pelvic examination
- Laboratory evaluation: Stool evaluation for occult blood; urinalysis; complete blood count; liver function tests; calcium, electrolytes, creatinine; measurement of serum levels of hCG, AFP, CEA, and CA-125 (women); chest X-ray; abdominal and pelvic CT; mammography.

Pathological Evaluation or Biopsy

Possible pathologic evaluation of biopsy specimens from patients with metastatic cancer of unknown primary site:

Evaluation/findings *Suggested primary site or neoplasm*

HISTOLOGY (HEMATOXYLIN AND EOSIN STAINING)

Psammoma bodies, papillary configuration Ovary, thyroid
Signet ring cells Stomach

IMMUNOHISTOLOGY

Leukocyte common antigen (LCA, CD45)	Lymphoid neoplasm
Leu-M1	Hodgkin’s disease
Epithelial membrane antigen	Carcinoma
Cytokeratin	Carcinoma ^a
CEA	Carcinoma
HMB45	Melanoma
Desmin	Sarcoma
Thyroglobulin	Thyroid carcinoma
Calcitonin	Medullary carcinoma of the thyroid
Myoglobin	Rhabdomyosarcoma
PSA/prostatic acid phosphatase	Prostate
AFP	Liver, stomach, germ cell
Placental alkaline phosphatase	Germ cell
B, T cell markers	Lymphoid neoplasm
S-100 protein	Neuroendocrine tumour, melanoma
Gross cystic fluid protein	Breast, sweat gland
Factor VIII	Kaposi’s sarcoma, angiosarcoma



FLOW CYTOMETRY

B, T cell markers Lymphoid neoplasm

ULTRASTRUCTURE

Actin-myosin filaments Rhabdomyosarcoma
 Secretory granules Neuroendocrine tumours
 Desmosomes Carcinoma
 Premelanosomes Melanoma

CYTOGENETICS

Isochromosome 12p; 12q(-) Germ cell
 t(11;22) Ewing's sarcoma, primitive neuroectodermal tumour
 t(8;14) Lymphoid neoplasm
 3p(-) Small cell lung carcinoma; renal cell carcinoma, mesothelioma
 t(X;18) Synovial sarcoma
 t(12;16) Myxoid liposarcoma
 t(12;22) Clear cell sarcoma (melanoma of soft parts)
 t(2;13) Alveolar rhabdomyosarcoma
 1p(-) Neuroblastoma

RECEPTOR ANALYSIS

Oestrogen/progesterone receptor Breast

MOLECULAR BIOLOGIC STUDIES

Immunoglobulin, bcl-2, T-cell Lymphoid neoplasm
 receptor gene rearrangement



Management Protocol

Presentations that dictate specific therapies in patients with CUPS. See Table on next page.

Principles of Cancer Therapy

The ultimate aim of cancer therapy is to totally eradicate the cancer. When eradication is not possible the next goal of cancer therapy is palliation. The palliative therapy aims to achieve amelioration of symptoms, preserve the quality of life and to prolong longevity.

There are 4 modalities of cancer therapy:

1. Surgery
2. Radiation including photodynamic therapy
3. Chemotherapy including hormonal treatment
4. Biologic therapy including immunotherapy.

Surgery

Surgical modality is useful in prevention, diagnosis, staging, and eradication of cancer. It is also useful in palliation and rehabilitation.

Prevention

- Resection of premalignant lesions—skin, colon, cervix, oral cavity

- Colectomy for ulcerative colitis and familial polyposis
- Thyroidectomy for MEN 2
- Orchiectomy for undescended testis
- Mastectomy and oophorectomy for familial breast and ovarian cancer.

Diagnosis

Various types of biopsy procedures.

Staging

- Laparotomy and lymph node sampling for lymphoma and intra-abdominal cancers
- Axillary lymph node for breast cancers.



Treatment

- Surgery is the best and most effective modality of cancer therapy
- Surgery cures 40% of cancer patients
- Surgical removal of tumour helps in preserving the organ function, e.g. Ca bladder and Ca larynx
- Debulking is helpful for subsequent effective therapy
- For hormonally responsive tumours—oophorectomy, adrenalectomy, orchiectomy.

Palliation

- Surgical procedures for malignant effusions
- Insertion of central venous catheters
- Surgical bypass for intestinal, urinary and biliary obstruction
- Caval interruption for recurrent pulmonary emboli.

Rehabilitation

- Orthopaedic procedures for early ambulation
- Reconstructive plastic surgery.

Radiation Therapy

- Tumour tissue is more sensitive to radiation than normal tissue
- There are three ways of delivering radiation
 1. Teletherapy—radiation beams generated at a distance
 2. Brachytherapy—encapsulated sources of radiation directly implanted into tumour tissue
 3. Radionuclide therapy
- Hypoxic cells are relatively resistant to radiotherapy
- Non-dividing cells are more resistant than dividing cells
- A Rad (radiation absorbed dose) is 100 ergs of energy per gm of tissue
- Gy(Gray)—A Gy is 100 rads.

<i>Clinicopathologic features</i>	<i>Suspected primary site</i>	<i>Suggested therapy</i>
Squamous cell carcinoma, cervical node Carcinoma, axillary nodes (female)	Head and neck cancer Breast cancer	Radical neck dissection; radiotherapy ± chemotherapy Breast radiotherapy or mastectomy, systemic adjuvant therapy
Peritoneal carcinomatosis (female)	Ovarian cancer	Debulking surgery, cisplatin-based chemotherapy
Pleural effusion, adenocarcinoma cells oestrogen and/or progesterone receptor positive	Breast cancer	Systemic therapy for metastatic breast cancer
Poorly differentiated cancer, age < 50, lung or retroperitoneal or mediastinal mass or lymph nodes, elevated serum β hCG or AFP levels	Germ cell tumour (extragonadal)	Cisplatin/VP-16-based chemotherapy (controversial)
Bony metastases (male)	Prostate cancer	Androgen blockade (leuprolide plus flutamide)
Adenocarcinoma, liver metastases, elevated CEA level	Gastrointestinal malignancy	Surgical resection of liver lesion feasible; colonoscopy with resection (if appropriate) of tumours; 5-fluorouracil/leucovorin

Teletherapy

- Teletherapy is most commonly used
- All radiation therapy is given for 5 days a week.

Curative Radiation Therapy

- Breast cancer
- Hodgkin's disease
- Head and neck cancer
- Gynaecological cancers
- Prostate cancers.

Palliative Radiation Therapy

- Control of brain metastasis
- Relief of bone pain from metastasis
- Relief of SVC obstruction
- Relief of spinal cord compression
- Prevention of meningeal involvement and brain metastasis.

Brachytherapy

- Brain tumour
- Cervical cancer.

Radionuclide Therapy

- Iodine 131 for thyroid cancer
- Strontium 89 and Samarium 153 for bone lesions.

Radioimmunotherapy

Delivering monoclonal antibodies attached to radioisotopes

For example, iodine 131 labelled anti CD 20

Yttrium 90 labelled anti CD 20

Both are active in B cell lymphoma.

Photodynamic Therapy

Cancer cells selectively absorb certain chemicals like porphyrins and phthalocyanines. When laser light is delivered these cells generate free radicals and the cells die. This modality is used in skin, lung, ovarian, oesophageal and colorectal cancers.

Toxicity of Radiation Therapy

This depends on the field of radiation.

General

Fatigue, anorexia, nausea, vomiting

Local

Mucositis

Skin erythema

Bone marrow toxicity

Thyroid failure

Cataracts

Retinal damage

Cessation of salivary secretion

Taste and smell affection

Testicular and ovarian affection

Development of second solid tumours in the second decade.

Chemotherapy

Principles of Chemotherapy

- Strictly adhere to a treatment plan since the chemotherapeutic agents have low therapeutic index.



- Chemotherapy is usually based on body surface area.
- Do a CBC before each cycle of chemotherapy.
- Adjust the drug dosage for the following conditions—weight loss, neutropaenia, thrombocytopaenia, stomatitis, diarrhoea, limited metabolic capacity of the drug, liver or renal failure.
- Oral drug administration—antiemetics if the drug induces nausea and vomiting.
- IV infusion—Proper placement of large calibre needle through a upper limb vein—veins of antecubital fossa, wrist, or dorsum of the hand (avoid the arm ipsilateral to an axillary lymph node resection).
- Indwelling venous catheter in case of poor peripheral venous access.
- Intrathecal chemotherapy is administered for meningeal carcinomatosis or as CNS prophylaxis. Drain 5-10 mL of CSF and give 10 mg of diluted methotrexate over 5-10 minutes.

To decrease the risk of arachnoiditis, patient should remain in the supine position for 15 minutes after infusion.

Slow release cytarabine 50 mg or ara-C 50-100 mg diluted in 10 mL are alternative drugs.

- Intracavitary instillation—thiotepa 30-60 mg is instilled in the bladder in CA bladder. Doxorubicin and cisplatin have been used in peritoneal metastasis.
- Intra-arterial chemotherapy – for achieving high drug concentration at the tumour site (theoretical advantage).

It has several phases.

Induction

It is the chemotherapy used to achieve a complete remission.

Consolidation

Here chemotherapy is administered to patients who initially responded to treatment.

Maintenance

This refers to low dose outpatient treatment to prolong remission.

Adjuvant chemotherapy

This is given after surgical or radiological management of primary malignancy.

Neo-adjuvant chemotherapy

It is given in the presence of local disease, before planned local therapy.

Survival Data

Median survival: It quantifies the period of time during which 50% of studied subjects are alive and 50% are dead.

Five year survival: It quantifies the percentage of patients studied who are alive at five years.

Classification of Anticancer Drugs

There are six main groups of drugs.

1. Antimetabolites: By inhibiting the folate metabolism, they interfere with synthesis of purines and pyrimidines.
2. Alkylating agents: Addition of alkyl group to constituents of DNA interferes with replication and transcription of mRNA, leading to cell death.
3. Plant alkaloids: They inhibit cell division by binding to tubulin and disrupting the mitotic spindle.
4. Antibiotics: They act by intercalating between base pairs and DNA.
5. Taxanes: They act by stabilizing the mitotic spindle
6. Miscellaneous synthetic compounds
 - Dacarbazine
 - Cisplatin
 - Procarbazine
 - Hexamethylmelamine
 - Hydroxyurea
 - Mitozantrone.

Response to Treatment

Complete response/remission

Malignancy with all its evidence is eradicated

Partial response

Decreases in tumour mass by more than 50%.

Curability of Cancers with Chemotherapy

A. Advanced Cancers with Possible Cure

- Acute lymphoid and acute myeloid leukaemia (paediatric/adult)
- Hodgkin's disease (paediatric/adult)
- Lymphomas—certain types (paediatric/adult)
- Small cell lung carcinoma
- *Germ cell neoplasms*
 - Embryonal carcinoma
 - Teratocarcinoma
 - Choriocarcinoma
 - Seminoma or dysgerminoma
- Gestational trophoblastic neoplasia
- Ovarian carcinoma
- *Paediatric neoplasms*
 - Ewing's sarcoma
 - Peripheral neuroepithelioma
 - Neuroblastoma
 - Wilms' tumour
 - Embryonal rhabdomyosarcoma.

B. Advanced cancers possibly cured by chemotherapy and radiation

- Squamous carcinoma (head and neck)
- Squamous carcinoma (anus)
- Breast carcinoma
- Carcinoma of the uterine cervix
- Non-small cell lung carcinoma (stage III)
- Small cell lung carcinoma.

C. Cancers possibly cured with chemotherapy as adjuvant to surgery

- Breast carcinoma
- Colorectal carcinoma
- Osteogenic sarcoma
- Soft tissue sarcoma.

D. Cancers possibly cured with “high-dose” chemotherapy with stem cell support

- Relapsed leukaemias, lymphoid and myeloid
- Relapsed lymphomas, Hodgkin’s and non-Hodgkin’s
- Chronic myeloid leukaemia
- Multiple myeloma.

E. Cancers responsive with useful palliation, but not cure, by chemotherapy

- Bladder carcinoma
- Chronic myeloid leukaemia
- Hairy cell leukaemia
- Chronic lymphocytic leukaemia
- Lymphoma-certain types
- Multiple myeloma
- Gastric carcinoma
- Cervix carcinoma
- Endometrial carcinoma
- Soft tissue sarcoma
- Head and neck cancer
- Adrenocortical carcinoma
- Islet-cell neoplasms
- Breast carcinoma.

F. Tumour poorly responsive in advanced stages to chemotherapy

- Pancreatic carcinoma
- Biliary-tract neoplasms
- Renal carcinoma
- Thyroid carcinoma
- Carcinoma of the vulva
- Colorectal carcinoma
- Non-small cell lung carcinoma
- Prostate carcinoma
- Melanoma
- Hepatocellular carcinoma.

Therapy of Selected Cancers**Gastric Cancers**

- Adenocarcinoma—localized lesions—early surgery
- Advanced unresectable—may benefit by chemotherapy and radiation
- Metastatic disease—palliation by chemotherapy.

Oesophageal Cancer

- Squamous cell/adenocarcinoma
- Surgical resection of oesophagus or chemo-radiation followed by resection
- Unresectable growth—chemotherapy and radiation
- Metastatic disease—palliation by chemotherapy
- Obstructive complication—stenting.

Colon Cancer

- Adenocarcinoma—surgical resection.
- Regional lymph node involvement—5FU and Levamisole for 12 months.
- Or 5 FU and Leucovorin for 6 months.
- FU, irinotecan, capecitabine, and oxaliplatin have been used to treat the metastatic colorectal cancer. Addition of irinotecan to FU/LV regimen prolongs survival rate.
- Three more new monoclonal antibodies have been approved for the treatment of metastatic colonic cancer. Bevacizumab targets vascular endothelial growth factor (VEGF); cetuximab and panitumumab target epidermal growth factor (EGFR).
- Liver resection if the metastasis is confined to liver in selected cases.

Rectal Cancer

- Recurs locally after surgery
- Postoperative radiation and 5FU are recommended.

Anal Cancer

- Chemotherapy and radiation offer high cure rates than surgical resection
- This modality preserves anal sphincter and fecal continence.

Breast Cancer

- Tylectomy—lumpectomy and axillary lymph node dissection
- As effective as modified radical mastectomy



Commonly Used Cancer Chemotherapy Agents

Drug	Examples of usual doses	Toxicity	Interactions, issues
Direct DNA-Interacting Agents			
Alkylators			
Cyclophosphamide	400-2000 mg/m ² IV 100 mg/m ² PO qd	Marrow (relative platelet sparing) Cystitis Common alkylator Cardiac (high dose)	Liver metabolism required to activate to phosphoramidate mustard + acrolein MESNA protects against "high-dose" bladder damage
Mechlorethamine	6 mg/m ² IV day 1 and day 8	Marrow Vesicant Nausea	Topical use in cutaneous lymphoma
Chlorambucil	1-3 mg/m ² qd PO	Marrow Common alkylator	
Busulphan	2-4 mg PO	Interstitial pneumonitis, gynaecomastia	CI-pregnancy Breast feeding
Temozolomide dose (used in primary and metastatic brain tumours)	5 mg		CI- pregnancy Breast feeding
Thiotepa (for intra-cavitary administration in malignant effusions and bladder cancer)	60-90 mg in 100 mL of water		
Melphalan	8 mg/m ² qd × 5, PO	Marrow (delayed nadir) GI (high dose)	Decreased renal function delays clearance
BCNU	200 mg/m ² IV 150 mg/m ² PO	Marrow (delayed nadir) GI, liver (high dose) Renal	
CCNU	100-300 mg/m ² PO	Marrow (delayed nadir)	
Ifosfamide	1.2 g/m ² per day qd × 5 + MESNA	Myelosuppressive Bladder Neurologic Metabolic acidosis Neuropathy	Isomeric analogue of cyclophosphamide More lipid soluble Greater activity vs testicular neoplasms and sarcomas Must use MESNA
Procarbazine	100 mg/m ² per day qd × 14	Marrow Nausea Neurologic Common alkylator	Liver and tissue metabolism required Disulfiram-like effect with ethanol Acts as MAOI HBP after tyrosinase-rich foods
DTIC	375 mg/m ² IV day 1 and day 15	Marrow Nausea Flulike	Metabolic activation
Hexamethylmelamine	260 mg/m ² per day qd × 14-21 as 4 divided oral doses	Nausea Neurologic (mood swing) Neuropathy Marrow (less)	Liver activation Barbiturates enhance/cimetidine diminishes
Cisplatin	20 mg/m ² qd × 5 IV 1 q3-4 weeks or 100-200 mg/m ² / dose IV q3-4 weeks	Nausea Neuropathy Auditory Marrow platelets > WBCs Renal Mg ²⁺ , Ca ²⁺	Maintain high urine flow; osmotic diuresis, monitor intake/output K ⁺ , Mg ²⁺ Emetogenic-prophylaxis needed Full dose if CrCl > 60 mL/min and tolerate fluid push
Carboplatin	365 mg/m ² IV q3-4 weeks as adjusted for CrCl	Marrow platelets > WBCs Nausea Renal (high dose)	Reduce dose according to CrCl: AUC = dose/(CrCl + 25) to AUC of 5-7 mg/mL per min
Oxaliplatin- colorectal cancer		Sensory neuropathy	Monitor renal function
Antitumour Antibiotics			
Bleomycin	15-25 mg/d qd × 5 IV bolus or continuous IV	Pulmonary Skin effects Raynaud's hypersensitivity	Inactivate by bleomycin hydrolase (decreased in lung/skin) O ₂ enhances pulmonary toxicity Cisplatin-induced decrease in CrCl may increase skin/lung toxicity Reduce dose if CrCl < 60 mL/min

Contd...

Contd...

Drug	Examples of usual doses	Toxicity	Interactions, issues
Actinomycin D	10-15 µg/kg per day qd × 5 IV bolus	Marrow Nausea Mucositis Vesicant Alopecia	Radiation recall
Mithramycin	15-20 µg/kg qd × 4-7 (hypercalcaemia) or 50 µg/kg qod × 3-8 (antineoplastic)	Marrow Liver Renal Mucositis Hypocalcaemia Nausea Vesicant Myelosuppression	Acute haemorrhagic syndrome
2-Deoxycoformycin (Pentostatin) (used in hairy cell leukaemia)			
Mitomycin C	6-10 mg/m ² q6 weeks	Marrow Vesicant Haemolytic-uraemic syndrome Lung CV-heart failure	Treat superficial bladder cancers by intravesical infusion Delayed marrow toxicity Cumulative marrow toxicity
Etoposide (VP16-213)	100-150 mg/m ² IV qd × 3-5d or 50 mg/m ² PO qd × 21d or up to 1500 mg/m ² /of dose (high dose with stem cell support)	Marrow (WBCs > platelet) Alopecia Hypotension Hypersensitivity (rapid IV) Nausea Mucositis (high dose)	Hepatic metabolism—renal 30% Reduce doses with renal failure Schedule-dependant (5 day better than 1 day) Late leukemogenic Accentuate antimetabolite action
Teniposide (VM-26)	150-200 mg/m ² twice per week for 4 weeks	Marrow Alopecia	
Amsacrine	100-150 mg/m ² IV qd × 5	Marrow Mucositis Nausea CV-arrhythmia (avoid hypokalaemia)	Decrease dose by 30% if liver or renal failure
Topotecan	20 mg/m ² IV q3-4 weeks over 30 min or 1.5-3 mg/m ² q3-4 weeks over 24 h or 0.5 mg/m ² per day over 21 days	Marrow Mucositis Nausea Mild alopecia	Reduce dose with renal failure No liver toxicity
Irinotecan (CPT II)	100-150 mg/m ² IV over 90 min q3-4 weeks or 30 mg/m ² per day over 120 h	Diarrhoea: "early onset" with cramping, flushing, vomiting; "late onset" after several doses Marrow Alopecia Nausea Vomiting Pulmonary	Prodrug requires enzymatic clearance to active drug "SN 38" "Early diarrhoea" likely due to biliary excretion Late diarrhoea, use "high-dose" loperamide (2 mg q2-4 h)
Doxorubicin and daunorubicin	45-60 mg/m ² dose q3-4 weeks or 10-30 mg/m ² dose q week or continuous-infusion regimen	Marrow Mucositis Alopecia Cardiovascular acute/chronic Vesicant	Heparin aggregate; coadministration increases clearance Tylenol, BCNU increase liver toxicity Radiation recall
Idarubicin	10-15 mg/m ² IV q 3 weeks or 10 mg/m ² IV qd × 3	Marrow Cardiac (less than doxorubicin)	None established
Epirubicin	150 mg/m ² IV q3 weeks	Marrow Cardiac	None established

Contd...



Contd...

Drug	Examples of usual doses	Toxicity	Interactions, issues
Mitoxantrone	12 mg/m ² qd × 3 or 12-14 mg/m ² q3 weeks	Marrow Cardiac (less than doxorubicin) Vesicant (mild) Blue urine, sclerae, nails	Interacts with heparin Less alopecia, nausea than doxorubicin Radiation recall
Indirect DNA-Interacting Agents			
<i>Antimetabolites</i>			
Deoxycoformycin	4 mg/m ² IV every other week	Nausea Immunosuppression Neurologic Renal	Excretes in urine Reduce dose for renal failure Inhibits adenosine deaminase
6-Mercaptopurine	75 mg/m ² PO or up 500 mg/m ² PO (high dose)	Marrow Liver Nausea	Variable bioavailability Metabolize by xanthine oxidase Decrease dose with allopurinol Increased toxicity with thiopurine methyltransferase deficiency
6-Thioguanine	2-3 mg/kg per day for up to 3-4 weeks	Marrow Liver Nausea	Variable bioavailability Increased toxicity with thiopurine methyltransferase deficiency
Azathioprine	1-5 mg/kg per day	Marrow Nausea Liver	Metabolizes to 6-MP, therefore reduce dose with allopurinol Increased toxicity with thiopurine methyltransferase deficiency
2-Chlorodeoxy-adenosine	0.09 mg/kg per day qd × 7 as continuous infusion	Marrow Renal Fever	Notable use in hairy cell leukaemia
Hydroxyurea	20-50 mg/kg (lean body weight) PO qd or 1-3 g/d	Marrow Nausea Mucositis Skin changes Rare renal, liver, lung, CNS	Decrease dose with renal failure Augments antimetabolite effect
Methotrexate	15-30 mg PO or IM qd × 3-5 or 30 mg IV days 1 and 8 or 1.5-12 g/m ² per day (with leucovorin)	Marrow Liver/lung Renal tubular Mucositis	Rescue with leucovorin Excreted in urine Decrease dose in renal failure NSAIDs increase renal toxicity
5-Fluorouracil	375 mg/m ² IV qd × 5 or 600 mg/m ² IV days 1 and 8	Marrow Mucositis Neurologic Skin changes	Toxicity enhanced by leucovorin Dihydropyrimidine dehydrogenase deficiency increases toxicity Metabolizes in tissues
Cytosine arabinoside	100 mg/m ² per day qd × 7 by continuous infusion or 1-3 g/m ² dose IV bolus	Marrow Mucositis Neurologic (high dose) Conjunctivitis (high dose) Noncardiogenic pulmonary oedema	Enhances activity of alkylating agents Metabolizes in tissues by deamination
Azacitidine	750 mg/m ² per week or 150-200 mg/m ² per day × 5-10 (bolus) or (continuous IV)	Marrow Nausea Liver Neurologic Myalgia	Use limited to leukaemia Altered methylation of DNA alters gene expression
Gemcitabine	1000 mg/m ² IV weekly × 7	Marrow Nausea Hepatic Fever/"flu syndrome"	

Contd...

*Contd...*

<i>Drug</i>	<i>Examples of usual doses</i>	<i>Toxicity</i>	<i>Interactions, issues</i>
Fludarabine phosphate	25 mg/m ² IV qd × 5	Marrow Neurologic Lung	Dose reduction with renal failure Metabolised to F-ara converted to F-ara ATP in cells by deoxycytidine kinase
Asparaginase	25,000 IU/m ² q3-4 weeks or 6000 IU/m ² per day qod for 3-4 weeks or 1000-2000 IU/m ² for 10-20 days	Protein synthesis Clotting factors Glucose Albumin Hypersensitivity CNS Pancreatitis Hepatic	Blocks methotrexate action
<i>Antimitotic Agents</i>			
Vincristine	1-1.4 mg/m ² per week	Vesicant Marrow Neurologic GI: ileus/constipation; bladder hypotonicity; SIADH Cardiovascular	Hepatic clearance Dose reduction for bilirubin >1.5 mg/dL Prophylactic bowel regimen
Vinblastine	6-8 mg/m ² per week	Vesicant Marrow Neurologic (less common but similar spectrum to other vincas) Hypertension Raynaud's	Hepatic clearance Dose reduction as with vincristine
Vinorelbine	15-30 mg/m ² per week	Vesicant Marrow Allergic/bronchospasm (immediate) Dyspnoea/cough (subacute) Neurologic (less prominent but similar spectrum to other vincas)	Hepatic clearance
Paclitaxel	135-175 mg/m ² per 24-h infusion or 175 mg/m ² per 3-h infusion or 140 mg/m ² per 96-h infusion or 250 mg/m ² per 24-h infusion plus G-CSF	Hypersensitivity Marrow Mucositis Alopecia Sensory neuropathy CV conduction disturbance Nausea-infrequent	Premedicate with steroids, H ₁ and H ₂ blockers Hepatic clearance Dose reduction as with vincas
Docetaxel	100 mg/m ² per 1-h infusion q3 weeks	Hypersensitivity Fluid retention syndrome Marrow Dermatologic Sensory neuropathy Nausea infrequent Some stomatitis	Premedicate with steroids, H ₁ and H ₂ blockers
Estramustine phosphate	14 mg/kg per day in 3-4 divided doses with water >2 h after meals Avoid Ca ²⁺ -rich foods	Nausea Vomiting Diarrhoea CHF Thrombosis Gynaecomastia	
<i>Hormonal Agents</i>			
Tamoxifen	10 mg orally BD	hormone flare after 7-14 days of treatment (bone pain, erythema, hypercalcaemia) Endometrial cancer, DVT	Hormone flare does not require stopping therapy. Long-term administration is not associated with systemic antiestrogen effect

Contd...



Contd...

Drug	Examples of usual doses	Toxicity	Interactions, issues
Aromatase inhibitors are used in hormone responsive breast cancer (Postmenopausal).			
i. Anastrozole	1 mg/day		Hot flushes, sweating, vaginal dryness/bleeding
ii. Letrozole	2.5 mg/day		Hot flushes and night sweats
iii. Exemestane	25 mg/day		Hot flushes, sweating, alopecia
Gonadotropin agonists			
Leuprolide acetate and Goserelin acetate	given as monthly subcutaneous depot injection should be monitored	flare up of symptoms	Signs of Neurologic dysfunction or urinary obstruction
Progestational agents			
Megestrol acetate and Medroxyprogesterone	40 mg QID PO 10 mg OD PO	weight gain, fluid retention, hot flashe.	Also used in cancer cachexia
Antiandrogens are used in advanced prostate cancer.			
i. Bicalutamide	150 mg/day	Nausea, vomiting, alopecia/hirsutism gynaecomastia, ILD, heart failure	
ii. Flutamide	250 mg tid	Nausea, vomiting, gynaecomastia HTN, SLE like syndrome, insomnia	
Immunotherapy			
Selective agents			
Trastuzumab	4 mg/kg over 90 mts On week 1 and 2 mg/kg over 30 mts weekly		Added on to first line therapy in metastatic breast cancer with over expression of her 2 gene
Rituximab	Administered weekly for 1 month	chills and fever hypersensitivity	Used in CD 20 positive low grade NHL
Alemtuzumab	(used in CLL)		High incidence of opportunistic infections.
Gemtuzumab	(used in myeloid leukaemias)		
Imatinib	(used in CML)		
Ibritumomab and iodine 131 tositumomab are radiolabeled antibodies used in NHL.			
Bevacizumab, cetuximab, and panitumumab are used in the treatment of colon cancer.			
Campath			Prophylactic antifungals and antivirals due to high incidence of opportunistic infections
Nonspecific immunotherapy			
Levamisole	50 mg PO TID for 3 days every alternate days		With 5FU used as an adjuvant therapy in colon cancer
Interferon α		Nausea, vomiting, flu like symptoms, headache	Acute symptoms responds to acetaminophen
Aldesleukin (IL2)		High doses cause increased vascular permeability, hypotension, prerenal azotemia, elevated liver enzymes	
Chemopreventive agents			
Retinoids	Isotretinoin 50-100 mg/m ² PO OD for 12 months	Dry skin, cheilitis Hyperlipidaemia, Elevated transaminases	Shown to decrease second primary tumour in those previously treated for head and neck cancer
Tamoxifen	20 mg/day 5 years		Decrease incidence of breast cancer in high-risk women

- Adjuvant chemotherapy- for patients with tumour size more than 1 cm or axillary node involvement or oestrogen receptor (ER) negative cancer or has over expression of her-2 especially in premenopausal women.
- ER positive breast cancers—tamoxifen 20 mg/day for 5 years.

Tamoxifen is useful only in premenopausal women.

In postmenopausal women, the aromatase inhibitors anastrozole, letrozole, and exemestane have replaced tamoxifen for adjuvant hormone therapy.

- Chemotherapy should be considered if there is no response to hormonal treatment.
- In her-2-overexpressing cancers, addition of trastuzumab to first line chemotherapy improved survival rate.
- In women with more than one osteolytic metastasis, the monthly administration of zoledronic acid 4 mg IV improves the quality of life and survival.
- In inflammatory or unresectable cancers (Peau d'orange changes or erythema involving larger area), because of high likelihood of metastasis at the time of diagnosis, surgery and radiation to control local lesion may have added effect in addition to initial chemotherapy.
- Radiation therapy—selected women with axillary nodal involvement.

Renal Cell Carcinoma

- Localized tumour—surgical resection
- Adjuvant therapy is not effective
- Metastatic disease—interferon α and interleukin 2 (response rate 15-30%)
- Sunitinib and sorafenib have been approved for the treatment of metastatic renal cancer. They are more active and better tolerated than previous drugs.

Bladder Cancer

- Unifocal tumour confined to mucosa—cystoscopy and transurethral resection—fulguration-repeated every 3 months
- Locally invasive cancer—surgical resection
- Multifocal mucosal disease—intravesical BCG or thiotepa or mitomycin C
- Metastatic/recurrent disease—cisplatin containing regimens.

Prostate Cancer

- Prostatectomy or radiation therapy

- Metastatic diseases—bilateral orchiectomy with LHRH analogues
- Hormone refractory disease—palliation by anthracyclines, taxanes, vinblastine and estramustine.
- Anaemia and bone pain—transfusions, growth factors and radiations.

Testicular Cancer

- Most curable malignancy with chemotherapy.
- Inguinal orchiectomy rather than trans-scrotal approach to prevent tumour spread to inguinal nodes.
- For seminoma- radiation therapy.
- For metastatic disease—cisplatin containing regimens.

Cancer Cervix

- Carcinoma *in situ*—endocervical cone biopsy
- Microinvasive disease—abdominal hysterectomy

Advanced local disease—Surgery followed by chemotherapy and radiation.

Inoperable cancer—Disease controlled with radiation

Metastatic disease—Cisplatin based chemotherapy

- A vaccine for HPV has recently been approved for young women to prevent and reduce the incidence of cervical carcinoma.

Ovarian Cancer

Staging and surgical treatment include:

Abdominal hysterectomy,
Bilateral oophorectomy,
Lymph node sampling,
Omentectomy,
Peritoneal cytology
Removal of all gross tumour.

Tumour localized to ovary—Surgery is curative.

Extension of tumour—Surgery followed by chemotherapy.

Endometrial Cancer

Surgery and radiation.

Head and Neck Cancer

Early lesions—Surgery, radiation or both

Chemotherapy added to radiation improves survival in nasopharyngeal cancers.

Disseminated disease—Chemotherapy.

Lung Cancer

Most patients have unresectable disease.



Small Cell Lung Cancer

Limited disease

Combination chemotherapy
Response rate 90% (median survival 12-18 months; cure rate 5-15%).

For patients with chemotherapy induced complete remission, prophylactic whole brain radiation therapy is advocated to prevent brain metastasis.

Extensive disease—Cure is rare (median survival is 6-9 months).

Non-small Cell Lung Cancer

Early lesion—Surgical resection

Unresectable lesion—Potentially curable by radiotherapy

Metastatic disease—Cisplatin based combination chemotherapy.

Erlotinib, a tyrosine kinase inhibitor targeting epidermal growth factor receptor (EGFR), is advised for non-small cell lung cancer.

Malignant Melanoma

Removal of tumour by excision biopsy.

Deeper invasion—Resection followed by high dose interferon

Systemic disease

Dacarbazine,
Interferon α ,
Interleukin 2.

Sarcomas

Soft Tissue Sarcoma

Early lesion—Surgical resection

Local or regional recurrence—Adjuvant radiation therapy

Metastatic disease

Doxorubicin,
Ifosfamide
Dacarbazine

Osteogenic Sarcoma

Surgical resection followed by adjuvant chemotherapy

Isolated pulmonary metastasis—Surgical resection.

Kaposi's Sarcoma

Local radiation therapy or vinblastine

Palliation therapy—Liposomal Doxorubicin.

Cancer with Unknown Primary Sites

This mode of presentation is common in 5% of cancer patients. Chemotherapeutic regimens do not improve survival.

Cervical adenopathy

Most likely to be squamous cell carcinoma
Most likely to be from head and neck cancer
Can be cured by radiation therapy.

Midline mass

Mediastinum/retroperitoneum
Extra gonadal germ cell cancer
Resection with cisplatin based chemotherapy.

Symptom Control in Severe Cancer

Pain

Scale for Grading Pain

- Grade 1* Pain relieved by occasional mild analgesics
Grade 2 Pain requiring regular mild analgesics
Grade 3 Pain requiring regular medium strength analgesics
Grade 4 Pain requiring regular strong analgesics
Grade 5 Pain not controlled by regular strong analgesics.

Try to eliminate pain. Do not be miserly with analgesics.

The analgesic ladder

- i. Nonopioid—NSAIDs (Aspirin, paracetamol, diclofenac, etc.)
- ii. Weak opioid—Codeine, Dihydrocodeine, Dextropropoxyphene
- iii. Strong opioid—Morphine, Diamorphine, Buprinorphine.

Relieve the pain by moving up the ladder.

Oral morphine 10 mg QID or TID or 30 mg rectal suppository.

Local Measures

1. Injection of anesthetics—Spinal-epidural-intrathecal-subarachnoid
2. Neurosurgical ablation—neurectomy, sympathectomy, cordotomy, hypophysectomy
3. TENS—Transcutaneous electrical nerve stimulation.

Nausea and Vomiting



Causes

Radio/chemotherapy
 Uraemia/hypocalcaemia
 Raised intracranial pressure
 Intestinal obstruction
 Oesophageal reflux
 Delayed gastric emptying
 Gastric irritation.

Antiemetics

Ondansetron 4-8 mg TID PO/IV
 Haloperidol 1-20 mg PO
 Cyclizine 50-100 mg PO
 Metoclopramide 10-20 mg QID or TID PO
 Cisapride 10-20 mg QID or TID PO

Stop NSAIDs and give H₂ blockers.

Pruritus



Causes

Drug reaction
 Cholestatic jaundice
 Renal failure
 Reticular system malignancy.



Management

Liquid paraffin for external use and antihistamine.

Hiccup

Stimulate pharyngeal nerve—cold drinks
 Reduce gastric distention—metoclopramide
 Elevate PaCO₂—hold breath, re-breathe into paper bag
 Haloperidol.

Breathlessness



Causes

Malignant pericardial effusion/pleural effusion
 Aspiration of fluid and intracavitary instillation of Bleomycin.

Pulmonary infection—appropriate antibiotics.
 Mass lesion—external beam radiotherapy
 Cardiac failure—treatment of failure
 Consider supplementary oxygen/morphine.

Cachexia/Anorexia

Due to altered carbohydrate, lipid and protein metabolism.

Prednisolone 10 mg/day or progestogen, megestrol 160-320 mg/day.

Constipation



Causes

- Reduced fluid and food intake
- Lack of mobility
- Opioid analgesics.



Management

- Lactulose
- Senna
- Bisacodyl.

Complications of Therapy

1. Extravasation

Extravasation of chemotherapeutic agents may occur from venous infusion resulting in erythema, ulceration, pain due to severe local tissue injury.



Management

Stop the infusion
 Aspirate 5 ml of blood from the venous line to remove any residual drug
 Instillation of appropriate agent to neutralize the chemical reaction
 Local hot or cold compress
 Skin grafting if needed.

2. Myelosuppression and Risk of Infection

Peak incidence of myelosuppression—7-14 days after chemotherapy

A. Neutropaenia

Greater risk of infection when neutrophil count is < 500/mm³

Appropriate broad spectrum antimicrobial regime.



Management of Extravasation of Selected Chemotherapeutic Agents

Drug	Compress	Antidote
Dacarbazine	Hot	Isotonic thiosulfate IV and SC
Daunorubicin	Cold	Dimethyl-sulfoxide applied topically over the vein
Doxorubicin	Cold	Dimethyl-sulfoxide applied topically over the vein
Etoposide	Hot	Hyaluronidase—150 U/ml -16 ml SC
Mechlorethamine	————	Isotonic thiosulfate—IV and SC
Mitomycin-C	————	Isotonic thiosulfate—IV and SC
Vinblastine	Hot	Hyaluronidase—150 U/ml -16 ml SC x 1
Vincristine	Hot	Hyaluronidase—150 U/ml -16 ml SC x 1

B. Thrombocytopenia

Count below 10,000/mm³ warrants platelet transfusion.

C. Anaemia

Haemoglobin concentration < 7 gm%

Anaemia is due to chemotherapy/radiation

RBC transfusions are indicated.

D. Growth factors

They ameliorate the myelosuppression.

Do not give within 24 hrs of chemotherapy/radiation, because they can increase myelosuppression

i. G-CSF—5 µg/kg SC/IV

Monitor blood count twice week

Common toxicity is bone pain—manage with NSAIDs

ii. GM-CSF- 250 µg/m²/day

iii. Erythropoietin—150 U/kg SC 3 times a week

iv. Interleukin 11—useful in the management of thrombocytopenia.

3. GI Toxicity

i. Nausea and vomiting

Cisplatin-

Ondansetron 8 mg iv 12 hrly BD or TID

Dexamethasone 16 mg in 20 ml NS over 10 to 15 mts at the time of cisplatin administration.

Cyclophosphamide, Ifosfamide-

Dexamethasone as above

Nitrogen mustard, DTIC

Lorazepam 2-4 mg IV 4th hrly

Doxorubicin

Domperidone 10-20 mg orally or as suppository 4-8 hourly

ii. Stomatitis

Mouth rinses with chlorhexidine 15-30 ml and 3% hydrogen peroxide

Antimicrobial coverage for super infection with candida/herpes simplex

iii. Diarrhoea

iv. Fluids/Loperamide

Diarrhoea due to 5 FU/Leucovorin—Octreotide 150-500 µg SC TID

4. Interstitial Pneumonitis

Stop the implicated agents and institute glucocorticoids.

5. Haemorrhagic Cystitis

This complication is common with cyclophosphamide/Ifosfamide

Anticipate and treat with prophylactic mesna

If the complication develop—continuous bladder irrigation with isotonic saline.

6. Tumour Lysis Syndrome

More common with NHL, Myeloma and acute leukaemia management

Rapid tumour cell death releases intracellular contents resulting in hyperkalaemia, hyperphosphataemia, hyperuricaemia and renal failure.

Prevention is with adequate hydration and Allopurinol 300-600 mg QID PO

Sodium bicarbonate 50 mEq/L IV fluid,

Alkalinize the urine above pH 7 to prevent uric acid nephropathy.

Indications for dialysis.

S. K⁺ > 6 mEq/L

S. Uric acid > 10 mg/dl

S. Creatinine > 10 mg/dl

S. Phosphate > 10 mg/dl

Increasing symptomatic hypocalcaemia.

7. Human Antibody Infusion Reactions

Infusion of Rituximab –

Adverse reactions:

Headache, fever, chills, nausea

Bronchospasm and hypotension in 1% of cases

Stop the infusion and restart with slow rate.

Recommendations for Antiemetic Therapy

Drugs	Dose	Route	Interval
<i>Phenothiazines</i>			
Prochlorperazine	5-10 mg	PO or IV	4-6th hourly
Prochlorperazine	25 mg	Per rectum	4-6th hourly
Chlorpromazine	10 mg	PO	4-6th hourly
Trimethobenzamide	100 mg	PO or IM	4-6th hourly
<i>Serotonin receptor antagonists</i>			
Granisetron	1-2 mg	IV or PO	30 minutes before chemotherapy
Ondansetron	8-32 mg	IV	30 minutes before chemotherapy
Dolasetron	100 mg	IV or PO	30 minutes before chemotherapy
<i>Butyrophenone</i>			
Droperidol	1-5 mg	IV	4-6th hourly
Metoclopramide	2-3 mg/kg	IV -q 2h × 3 doses	Before chemotherapy
<i>Antihistamine</i>			
Diphenhydramine	50 mg	PO or IV	4-6th hourly
<i>Anxiolytic</i>			
Lorazepam	1-2 mg	PO or IV	tid or qid
<i>Glucocorticoid</i>			
Dexamethasone	10-30 mg	IV	Before chemotherapy

8. Haemolytic Uremic Syndrome

Most common causative agent is mitomycin

Other agents—cisplatin, bleomycin, gemcitabine

HUS manifests 4-8 weeks after chemotherapy

HUS is characterised by microangiopathic haemolytic anaemia, thrombocytopenia and renal failure.



Clinical Features

Fatigue
Oliguria
Purpura
Hypertension
Pulmonary oedema.

Urine—hematuria, proteinuria, granular cast.

Plasmapheresis and plasma exchange are indicated.

9. Alopecia

This complication is caused by Doxorubicin and cyclophosphamide

Alopecia is reversible on cessation of therapy.

10. Altered Growth

Stunted physical growth is seen in children treated with chemotherapy/radiotherapy.

Intellectual impairment—there is conflicting evidence.

11. Impaired Fertility

This complication is more variable—subfertile to loss of fertility.

Cytotoxic drugs are potentially teratogenic—advise contraception.

12. Second Malignancy

Only certain class of anticancer drugs cause this complication.

Acute myelomonocytic leukaemia—5 years after use of Alkylating agents.

Following radiation second solid tumour development occurs in the second decade.

13. Psychological Effects

Common manifestations—anxiety/depression

Proper counseling and reassurance.

Late Effects of Cancer Therapy Surgical Procedure

Procedure	Effect
Amputation	Functional loss
Lymph node dissection	Risk of lymphoedema
Ostomy	Psychosocial impact
Splenectomy	Risk of sepsis
Adhesions	Risk of obstruction
Bowel anastomoses	Malabsorption syndromes



Radiation Therapy

<i>Organ</i>	<i>Effect</i>
Bone	Premature termination of growth, osteonecrosis
Soft tissues	Atrophy, fibrosis
Brain	Neuropsychiatric deficits, cognitive dysfunction
Thyroid	Hypothyroidism, Graves' disease, cancer
Salivary glands	Dry mouth, caries, dysgeusia
Eyes	Cataracts
Heart	Pericarditis, myocarditis, coronary artery disease
Lung	Pulmonary fibrosis
Kidney	Decreased function, hypertension
Liver	Decreased function
Intestine	Malabsorption, stricture
Gonads	Infertility, premature menopause
Any	Secondary neoplasia

Chemotherapy

<i>Organ</i>	<i>Drug</i>	<i>Effect</i>
Bone	Glucocorticoids	Osteoporosis, avascular necrosis
Brain	Methotrexate, ara-C, others	Neuropsychiatric deficits, cognitive decline?
Peripheral	Vincristine, platinum	Neuropathy, hearing loss nerves
Eyes	Glucocorticoids	Cataracts
Heart	Anthracyclines	Cardiomyopathy
Lung	Bleomycin	Pulmonary fibrosis
	Methotrexate	Pulmonary hypersensitivity
Kidney	Platinum, others	Decreased function, hypomagnesaemia
Liver	Various	Altered function
Gonads	Alkylating agents, others	Infertility, premature menopause
Bone marrow	Various	Aplasia, myelodysplasia, secondary leukaemia



Chapter 12

Geriatric Medicine

SYMPTOMS

ATYPICAL PRESENTATIONS

LATE PRESENTATIONS

PRESENCE OF MULTIPLE
PATHOLOGIES AND
CO-MORBIDITIES

COMMON PROBLEMS

FALLS

IMMOBILITY

INCONTINENCE

PRESSURE SORES

CONFUSION

CONSTIPATION

PAINFUL JOINTS

BREATHLESSNESS

DIZZINESS/BLACKOUTS

ANAEMIA

INFECTION

FLUID IMBALANCE

PEPTIC ULCER

STROKES

DEPRESSION

DEMENTIA

VISUAL IMPAIRMENT

HEARING IMPAIRMENT

PHYSICAL EXAMINATION

GENERAL EXAMINATION

Consciousness

Pallor

Pedal oedema

Hydration

Skin

Arcus senilis

Venous ulcers

Pressure sores

Leukoplakia

Dentures

VITAL SIGNS

Temperature

Hypo/hyperthermia

Respiration

Rate and pattern

Pulse

Rate/regularity

Condition of peripheral

Vessels

SYSTEM EXAMINATION

Cardiovascular system

Signs of heart failure

Atherosclerotic valve disease

Respiratory system

Rigid chest wall

Kyphosis

Evidence of pneumonia

Gastrointestinal system

Constipated faecal mass

Enlarged prostate

Nervous system

Orientation

Behaviour

Cognition

Speech

Memory

Vision/hearing

Gait

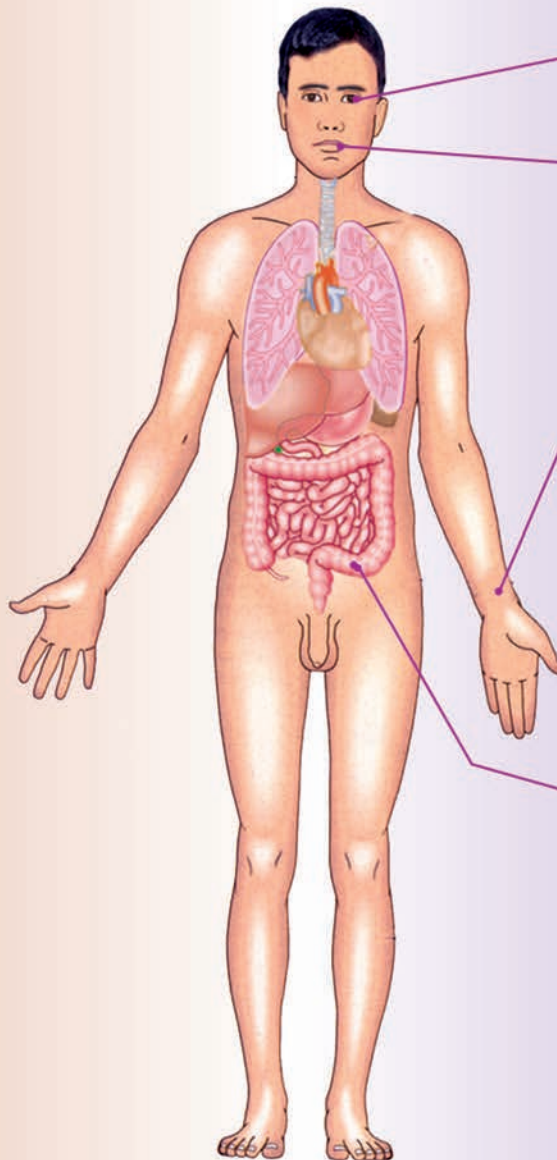



Introduction

One of the most striking changes in the demography of the world has been the increased proportion of elderly individuals in the population.

The relevance of this to health and social services is that there is an exponential increase in disability, and mental and physical morbidity, in individuals over the age of 75 years.

Ageing

Ageing can be described, from a physiologic standpoint, as a progressive constriction of the homeostatic reserve of every organ system. This decline, referred to as homeostasis is evident by the third decade and is then gradually progressive. The rate and extent of this decline of each organ system of the body is influenced by genetic factors, environment, diet and personal habits (the rate of deterioration in organ function often can be reduced by factors such as regular exercise, or accelerated by bad habits such as cigarette smoking or heavy alcohol consumption).

Therefore, with advancing age, there may be a moderate decline in organ function. This remains unchanged in some elderly individuals, whereas in others it is so severe that it leaves them seriously incapacitated.

It should also be borne in mind that the effects of ageing are usually insufficient to interfere with the function of an organ under baseline conditions, but the changes may be sufficient enough to reduce the reserve capacity of the organ in presence of stress of a mild illness or unaccustomed exercise and precipitate a crisis.

The practical value in defining the characteristics of normal ageing is that this provides a baseline against which the signs and symptoms of disease in elderly patients can be assessed.

Multiple pathology is so common in old age that elderly individuals free from disease form a biological elite.

Postulated Mechanisms for Ageing

1. Ageing may be due to cumulative spontaneous somatic mutations.
2. Ageing may result from errors in protein synthesis.
3. Ageing may be a result of ongoing DNA rearrangements.
4. Ageing may be a result of damage by free radicals.

An abrupt decline in any system or function is always due to disease and not due to "Normal Ageing".

Some Physiological Effects of Ageing

1. Skin and Integuments

Changes within the connective tissue result in the skin losing its elasticity and becoming wrinkled. The appearance is similar to that associated with dehydration, so that the dehydration is easily missed in elderly patients.

A decline in the number of sweat glands in the elderly results in difficulty in regulation of body temperature especially in warm weather and they are susceptible to heat stroke.

There is diffuse loss of hair, and the hair also becomes finer. In some individuals there is depigmentation of hair (grey hair).

2. Musculoskeletal System

There is a decline in the number of anterior horn cells with ageing which results in muscle weakness and wasting. The process often is accentuated by the physical inactivity and may be minimised by taking regular physical exercise.

3. Smell and Taste Sensation

There is a decline in taste sensation and the sense of smell with ageing, resulting in decreased appreciation of flavour of food.

4. Joints

There is development of degenerative changes in the joints, especially the weight bearing joints like the knee joint, with ageing, resulting in osteoarthritis.

Degeneration of the cervical and lumbar vertebrae and their intervertebral discs may lead to the development of cervical spondylosis and lumbar spondylosis.

5. Immune Function

Ageing, poor nutrition and chronic ill health in many old people interact with each other to interfere with immune function. Results of this include an attenuated inflammatory response so that the local and systemic effects of infection are masked, leading to atypical presentation of infectious diseases. A reduced immune surveillance in the elderly predisposes them to the development of malignancy.

Characteristics of Disease in Old Age

There are differences of emphasis in the approach to old people compared with young people, due to



Signs and Symptoms of Age Related Physiological Changes and their Consequences and Disease States in the Elderly

<i>Organ/system</i>	<i>Age-related physiological change</i>	<i>Symptoms/signs caused by age-related physiological change</i>	<i>Symptoms/signs caused by disease</i>
1. General	a. Increased body fat b. Decreased total body water.	Increased volume of distribution of fat soluble drugs Decreased volume of distribution of water soluble drugs.	Obesity Anorexia
2. Eyes	a. Presbyopia b. Lens opacification	Decreased accommodation Increased susceptibility to glare	Decreased acuity of vision (cataract formation)
3. Ears	Decreased high frequency acuity	Difficulty in discriminating words if background noise is present	Deafness (sensorineural)
4. Endocrine	a. Impaired glucose tolerance b. Decreased thyroxine clearance and/or production c. Decreased testosterone d. Decreased vitamin D absorption and activation	Stress hyperglycaemia Decreased T ₄ requirement in hypothyroidism Osteopenia	Diabetes mellitus Thyroid dysfunction (hypothyroidism or hyperthyroidism) Osteoporosis; osteomalacia
5. Respiratory system	Decreased lung elasticity and increased chest wall stiffness	Ventilation-perfusion mismatch and decreased PO ₂	Dyspnoea
6. Cardiovascular system	a. Decreased arterial compliance and increased systolic blood pressure b. Decreased β adrenergic responsiveness c. Decreased baroreceptor sensitivity and decreased SA node automaticity	Hypotensive response to volume depletion or loss of atrial contraction Decreased cardiac output Impaired blood pressure response to standing (postural hypotension)	Syncope Heart failure Heart block
7. GIT	a. Decreased hepatic function b. Decreased gastric acidity c. Decreased colonic motility	Delayed metabolism of drugs Decreased calcium absorption on empty stomach Constipation	Cirrhosis Osteoporosis; vitamin B ₁₂ deficiency Faecal impaction (leading to urinary incontinence or spurious diarrhoea)
8. Renal	Decreased GFR	Impaired excretion of some drugs	Increased serum creatinine
9. Genitourinary system	a. Vaginal/urethral mucosal atrophy b. Prostate enlargement	Dyspareunia; asymptomatic bacteriuria Increased residual urine volume	Symptomatic urinary tract infection Urinary incontinence; urinary retention
10. Nervous system	a. Decreased brain catecholamine synthesis b. Decreased brain dopaminergic synthesis c. Decreased righting reflexes d. Decreased stage 4 sleep e. Brain atrophy	- Stiff gait Increased body swaying Early morning awakening Forgetfulness	Depression Parkinson's disease Recurrent falls Sleep apnoea Dementia; delirium

presence of certain characteristic features of disease in the elderly.

1. *Multiple aetiology and pathology*: Several disease processes may combine to produce a symptom in an elderly individual (e.g. recurrent falls may be due to the presence of a combination of postural hypotension, decreased righting reflexes, decreased visual

acuity due to cataract and muscle weakness). This is in contrast to disease presentation in the young, whereby the same symptom may be due to any one of the above mentioned abnormalities.

In the elderly, therefore, treating each aetiology of the problem alone may do little good to the patient and treating all may be of great benefit.



2. *Non-specific presentation of disease:* Some presentations of disease are common in old age, in particular the 'geriatric giants' namely urinary incontinence, acute confusion, immobility and falls. Diseases may also present atypically in the elderly.
3. Many findings that are abnormal in young age may be relatively common in old people (bacteriuria, premature ventricular ectopics, isolated systolic hypertension, low bone mineral density, impaired glucose tolerance and uninhibited bladder contractions).
4. Rapid deterioration can occur if disease is untreated.
5. Complications are common.
6. More time is required for recovery.
7. There is impaired metabolism and excretion of drugs. Doses of drugs may need lowering.

Atypical Presentation of Disease in Elderly

The effect of age changes, impaired immunological function, poor nutrition, multiple pathology, sensory deficits, psychiatric disorders and intercurrent drug treatment interact to both modify and mask the typical symptoms and signs of disease in many elderly patients.

Giants of Geriatric Medicine

These refer to four of the most common causes of incapacity in elderly patients referred to a geriatric unit, namely acute confusion, urinary incontinence, immobility and falls.

1. Acute Confusion

Acute confusional state in an elderly patient usually is the result of organic disease, or a manifestation of drug

toxicity (esp. sedatives, hypnotics, antiemetics, or anticholinergics).

2. Urinary Incontinence

Confusion and immobility associated with acute illness often result in urinary incontinence. This usually settles with resolution of the illness, but in a proportion of cases, the incontinence persists.

A common neurological cause of chronic urinary incontinence is damage to the cerebral cortex with damage to normal bladder inhibition, so that the bladder has a small volume and increased tone, and empties frequently (uninhibited bladder). Disorders that are responsible for this are cerebrovascular disease, Alzheimer's disease or Parkinson's disease.

Spinal cord damage due to multiple sclerosis, trauma or a tumour, though less common in the elderly, can cause bladder dysfunction.

Damage to afferent parasympathetic fibres in disorders such as diabetic autonomic neuropathy gives rise to a large volume atonic bladder in which there is a continuous dribbling overflow incontinence.

Local causes of urinary incontinence may be due to pressure on the bladder due to faecal impaction, or prostatic enlargement.

Stress incontinence is often due to weakness of the pelvic floor muscles, especially in multiparous and post-menopausal women.

In post-menopausal women, atrophic changes in the vagina may be accompanied by similar abnormalities in the mucosa of the urethra and trigone due to lack of oestrogen resulting in urinary frequency and urge incontinence.

Drugs such as diuretics may cause incontinence.

Poor mobility and thereby a delay in reaching the lavatory may be the cause for incontinence.

Drugs that may Affect Continence

Medications	Examples	Effects on continence
NSAIDs	COX 2 inhibitors	Nocturnal diuresis due to fluid retention
Alcohol		Frequency, urgency, polyuria, sedation, delirium
Sedatives/Hypnotics	Benzodiazepines	Excess sedation, delirium
Narcotic analgesics	Morphine derivatives	Retention, faecal impaction, delirium, excess sedation
Anticholinergics	Dicyclomine, antihistamine	Retention – overflow
Antipsychotics	Haloperidol, thioridazine	Retention, rigidity, sedation
Antidepressants	Amitriptyline	Retention – overflow
Antiparkinsonians	Trihexyphenidyl	Retention – overflow
Calcium channel blockers	All dihydropyridines	Nocturnal diuresis due to fluid retention
Loop-diuretics	Furosemide, bumetanide	Polyuria, urgency, frequency
ACE inhibitors	Enalapril, lisinopril	Drug induced cough causing stress incontinence
Vincristine		Urinary retention



Disorders Presenting with Atypical Features in Elderly Patients

Disorders	Atypical presentation
Myocardial infarction	Confusion, weakness, fatigue, breathlessness and palpitations without chest pain. May also present with unexplained sweating, vomiting, postural hypotension or bowel urgency.
Bronchopneumonia	Confusion and rapid respiration, no pyrexia and minimal chest signs.
Appendicitis	Confusion, constipation or diarrhoea, no pyrexia and few localising signs.
Peptic ulcer	Anaemia, haematemesis or melaena without previous symptoms of dyspepsia.
Urinary tract infection	Confusion and urinary incontinence, no pyrexia or increased frequency or dysuria.
Dehydration	No thirst, and skin changes indistinguishable from those of ageing.
Hypothyroidism	Lethargy and general deterioration with no other characteristic symptoms and signs.
Thyrotoxicosis	Apathy, weight loss and cardiac signs (atrial arrhythmias) without anxiety, excess sweating or heat intolerance.
Diabetes mellitus	Asymptomatic until onset of complications, e.g. nephropathy, neuropathy or retinopathy.
Brain tumour	Confusion, drowsiness and focal neurological signs without headache or papilloedema.

In some patients, urinary incontinence is a manifestation of anxiety, or an attention-seeking device.



Management

The mainstay of management of urinary incontinence is proper and adequate toilet training in which the patient is encouraged to develop the habit of regular emptying of the bladder.

Faecal impaction if present should be treated.

An oestrogen cream should be used where there is atrophic vaginitis.

If there is stress incontinence, exercises for the pelvic floor should be taught to the patient.

In men, prostatectomy may relieve overflow incontinence.

As a last resort, intractable urinary incontinence should be managed by devices such as catheters, urinals, incontinence pads or marsupial pants.

3. Immobility

Age related changes in the neurological and musculo-skeletal system and a high prevalence of disorders such as stroke, Parkinson's disease, osteoarthritis and osteoporosis, interact to make poor mobility one of the most common problems to afflict elderly patients.

Since there often is little reserve capacity in skeletal muscles, even a short duration of bed-rest may render the patient immobile. It is therefore essential that an active rehabilitation programme be instituted as soon as possible after an episode of acute illness in order to prevent development of prolonged incapacitation.

4. Falls

There is an increased incidence of falls with advancing age.

Falls in the elderly usually have a plethora of causes. 50% are due to tripping or an accident.

About 10% are related to loss of consciousness or dizziness (due to vertebro-basilar insufficiency).

For the rest there is no clear cause.

Drug intake may be an important cause of falls (drugs causing postural hypotension, sedation or cardiac dysrhythmias).

Alcohol consumption may also cause falls in the elderly.

The consequences of falls in the elderly may be detrimental to the patient especially with development of fracture neck of femur or head injury resulting in subdural haematoma.

Prevention of falls in the elderly is very important as even a single fall can shatter the patient's confidence, even if no serious injury has been sustained.

Physiotherapy, which includes learning techniques to get up from the bed or floor and moving about carefully in the house may be of great benefit to the patient.

Postural Hypotension

Detection of presence of postural hypotension in the elderly is important as it is common in them and is also a common cause of falls and poor mobility.

Typical times of occurrence of postural hypotension are after meals, on exertion, and on getting up suddenly from the lying posture, especially at night. This may also manifest transiently with intercurrent illnesses (e.g. viral fever).

Postural hypotension may be due to venous insufficiency in the legs, autonomic neuropathy, drugs (diuretics, nitrates, antihypertensives, antidepressants, sedatives), or decreased baroreceptor response to pressure changes.

This can be managed by reducing the dose or stopping the causative drug. Patient may be taught the art of getting up slowly in stages from the lying posture. A trial of leg-compression stockings may be of help.



Risk factors for Fall and Possible Rehabilitation Measures

<i>Risk factors</i>	<i>Medical intervention</i>	<i>Rehabilitation</i>
Reduced visual acuity	Refraction, cataract surgery	Safety measures at home
Reduced hearing	Removal of wax, evaluation for hearing	Hearing aid if needed
Vestibular dysfunction	ENT/Neurological evaluation	Avoidance of drugs that affect the vestibular system
Dementia	Correct the treatable causes	Avoid sedation, home safety measures
Proprioceptive dysfunction	Correct vitamin B ₁₂ level, treat C. spondylosis	Correct size footwear, Walking aid
Postural hypotension	Screen the drugs consumed	Elevation of head end-bed
Sedatives	Use lowest effective dose	Slow and steady walk
Antihypertensives	Avoid postural hypotension	Check BP lying and standing
Musculoskeletal disorders	Neurological evaluation	Exercise and gait training

Some Adverse Reactions of Drugs Noticed in Geriatric Patients

<i>Drug</i>	<i>Side effects</i>
1. Sedatives and hypnotics	Confusional states, falls, incontinence
2. Antiemetics and neuroleptics	Parkinsonian syndrome, confusional state, postural hypotension, tardive dyskinesia, drowsiness, susceptibility to hypothermia
3. Diuretics	Dehydration, electrolyte imbalance, postural hypotension.
4. NSAIDs	Dyspepsia, upper GI bleed, oedema, cardiac failure.
5. Anticholinergics and antidepressants	Confusional states, urinary retention, constipation, dry mouth.

Some Drugs to be Avoided/Used with Caution in Disorders in the Elderly

<i>Disorder</i>	<i>Drugs to be avoided/used with caution</i>
1. Hypertension	Use vasodilators with caution as it can precipitate postural hypotension and stroke. β blockers and calcium channel blockers to be used with caution in presence of conduction defects and incipient cardiac failure. β blocker aggravates existing peripheral vascular insufficiency.
2. CCF	Use diuretics with caution as it can cause dehydration and electrolyte imbalance.
3. IHD	Use digoxin with care as digoxin toxicity may be precipitated especially when there is impaired renal excretion. Sublingual nitroglycerin to be administered in the lying posture as it may precipitate postural hypotension and falls if administered in the sitting or standing posture.
4. Mural thrombus	Oral anticoagulants (warfarin) to be used with caution as there may be increased activity due to reduced plasma binding of the drug. Prolonged use of heparin may exacerbate pre-existing osteoporosis and produce pathological fractures.
5. Bronchial asthma/COPD	Adrenaline must not be used as it can precipitate coronary vasospasm. Theophylline to be used with caution as impaired hepatic oxidation/hydroxylation can increase plasma level of the drug to toxic levels. β agonists (salbutamol) to be given in minimal optimal dose as it may precipitate tachycardia and IHD. Prolonged administration of steroids to be avoided as it may result in exacerbation of pre-existing osteoporosis and electrolyte imbalance (hypokalaemia).
6. Parkinson's disease	Avoid anticholinergics as it can precipitate glaucoma, urinary retention and confusional states.
7. Cerebrovascular accidents	Antioedema measures to be used with caution as it may precipitate dehydration and electrolyte imbalance Mannitol may precipitate renal failure and LVF when used in patients with impaired renal function.
8. Diarrhoea	Fluid and electrolyte loss should be carefully monitored and their replacement must be meticulous. Hypovolaemia and haemoconcentration can result in stroke, peripheral vascular occlusion and gangrene. Avoid use of antispasmodics or antimotility agents as they may produce paralytic ileus
9. Constipation	Avoid prolonged use of laxatives as they may produce hypokalaemia
10. Hypothyroidism	Replacement therapy with L-thyroxine should be initiated with minimal optimal dose and then gradually increased over 2–3 weeks. Initial high dose replacement may precipitate IHD.
11. Hyperthyroidism/senile tremors	Initiate propranolol therapy with caution as its serum level may be increased due to decreased first pass metabolism through the liver.
12. Psychiatric disorders	Antipsychotic drugs must be used with caution as they may cause falls and confusional states.



Fluid-retaining drugs such as fludrocortisone 0.1 mg per day orally may be helpful in those severely affected.

Principles of Management of Geriatric Problems

1. Avoid prolonged bed-rest whenever possible.
2. Patients should be positioned in the upright posture several times daily.
3. Skin over pressure points should be inspected frequently.
4. Drug therapy in the elderly should be employed only after nonpharmacologic means have been considered and tried.
5. Once pharmacotherapy has been decided upon, the drug should be started with the minimal optimal dose and thereafter the dose may be increased gradually as required.
6. The number of drugs administered should be as few as possible.
7. The dosage schedule of the drugs administered should be such that maximal patient compliance is attained as decreased compliance due to memory deficit is common in geriatric patients.
8. It must always be kept in mind, while prescribing drugs to geriatric patients that older people are more

likely to have adverse drug reactions due to the following factors:

- a. Drug clearance is often markedly reduced due to decreased renal plasma flow and GFR and a reduced hepatic clearance (due to decrease in activity of the drug metabolising microsomal enzymes and a decrease in blood flow to the liver).
- b. Volume of distribution of drug is affected due to decrease in total body water and increase in body fat (water soluble drugs become more concentrated and fat soluble drugs have longer half-lives).
- c. Serum albumin levels decline with ageing and so there is decrease in protein binding of some drugs (e.g. phenytoin, warfarin) and thereby more of the free (active) drug is available.

Drugs Cleared by the Kidney which should be Closely Monitored in the Elderly

- | | |
|-----------------------|--------------------------------------|
| 1. Antibiotics | Gentamicin, streptomycin, kanamycin. |
| 2. β blocker | Atenolol, sotalol. |
| 3. Cardiac glycoside | Digoxin. |
| 4. Psychotropic drugs | Lithium. |



Chapter 13

Substance Abuse

COMMON PRESENTATIONS

UNCONSCIOUS

NARCOTICS
BARBITURATES
ALCOHOL INTOXICATION
BENZODIAZEPINES

PSYCHOSIS/AGITATION

AMPHETAMINE
BENZODIAZEPINES
LSD
ALCOHOL WITHDRAWAL
CANNABIS

ASTHMA/DYSPNOEA

OPIATE INDUCED OEDEMA
HEROIN

FEVER/LUNG ABSCESS

IV DRUG ABUSERS
(Right sided IE)

HYPERPYREXIA

ECSTASY

ABSCESSSES OVER INJECTION SITES

TACHYARRHYTHMIAS

COCAINE
AMPHETAMINE
ENDOCARDITIS

JAUNDICE

HEPATITIS B,C,D
ANABOLIC STEROIDS

GLANDULAR FEVER

HIV SEROCONVERSION

RUNNY NOSE

OPIATE WITHDRAWAL
COCAINE

INFARCTIONS

COCAINE USE

CONSTIPATION

OPIATES

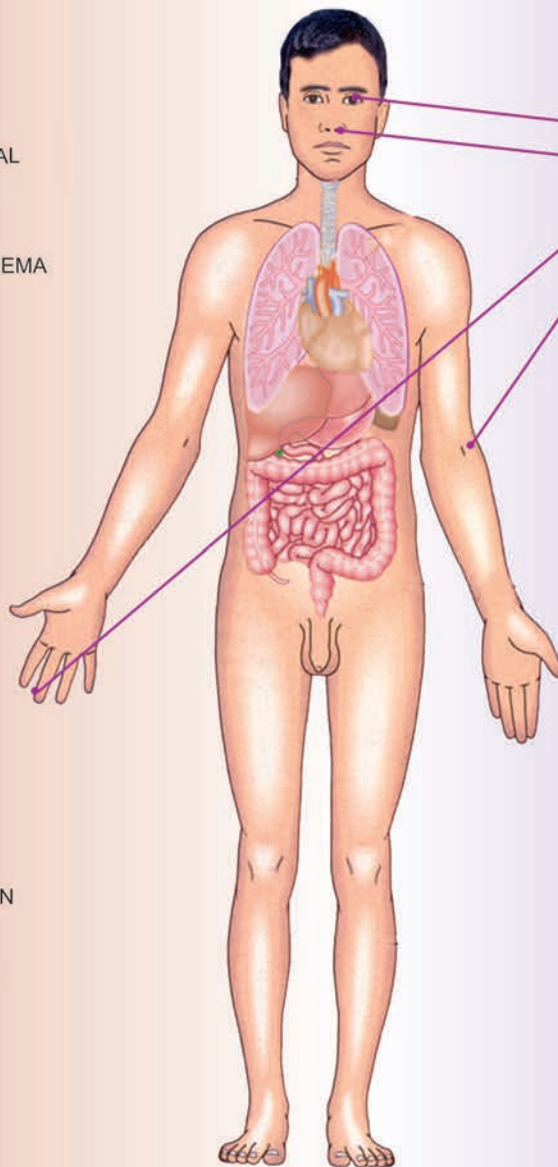

THE PHYSICAL EXAMINATION

LOOK FOR,

BEHAVIOURAL CLUES

Mood swings
Erratic behaviour
Agitation, etc.

PHYSICAL CLUES

Congested eyes
Small pupils (opiates)
Smell of alcohol/glues
Nicotine staining
Multiple needle tracks
Abscesses and regional
Lymphadenopathy

SMOKING



COPD
Lung cancer
CAD/PVD
Other malignancies

ALCOHOLISM



Delerium
Wernicke-Korsakoff's syndrome
Peripheral neuropathy
Alcoholic liver disease

CANNABIS



Transient psychiatric disorders
COPD
Psychological dependence

OPIOIDS



Acute intoxication
Physical dependence

COCAINE



Psychological dependence
Vaso-occlusive disease
Seizures
Nasal perforation

Alcohol

Alcoholic Equivalents

Whisky 30 ml	1 Unit	1 unit = 10 gm
Wine 100 ml	1 Unit	
Beer 250 ml	1 Unit	

Safe weekly limits of alcohol

For males	21 units/week
For females	14 units/week

Risk Factors for Alcoholic Liver Disease

1. Drinking Pattern

The average intake of alcohol of male cirrhotics was 160 gm/day/8 years. For most individuals, the dangerous dose is more than 80 gm of alcohol/day. The duration of consumption is also important. The liver injury is unrelated to the type of beverage. Continuous alcohol drinking is more dangerous than intermittent consumption.

2. Sex

Women develop higher blood ethanol values following a standard dose intake and it progresses from alcoholic hepatitis to cirrhosis even if they stop drinking. It is because the alcohol dehydrogenase, from the gastric mucosa contributes to alcohol metabolism. There is also a lower level of ADH.

3. Genetics

- The patient with HLA-B8, is more susceptible to alcoholic hepatitis.
- The heterozygotes for the ADH gene 2 have impaired metabolism of acetaldehyde.
- Hepatitis B and C act as a co-factor for alcoholic liver disease.

4. Nutrition

- Liver function does not improve with alcohol abstinence especially when dietary protein remains low.
- Alcohol increases the daily requirement of choline, folic acid and other nutrients.
- Protein deficiency promotes the toxic effect of alcohol.

5. Gastric First-pass Metabolism

The majority of oral ethanol is rapidly absorbed by passive diffusion from the stomach and the duodenum. But it has recently been suggested that after food, significant first-pass metabolism of ethanol occurs in the stomach mediated by gastric ADH.

Metabolism of Alcohol

Alcohol is metabolised by

- a. Microsomal ethanol oxidising systems (MEOS)
- b. Alcohol dehydrogenase

The MEOS is inducible by alcohol and microsomal P450 increases after alcohol.

Alcohol is metabolised by oxidation, converted to acetaldehydes by catabolising enzymes (ADH) and further converted to acetate by enzyme acetaldehyde dehydrogenase.

Consumption of alcohol results in gain of empty calories (nutritionally valueless). 1 gm of alcohol = 7 kilo calories. Alcohol is excreted through the lungs and also by body secretions (urine and sweat).

Effect of Alcohol on Liver

Mechanism of Liver Injury

1. Direct toxic effect of alcohol.
2. Acetaldehyde
 - a. Acetaldehyde binds with phospholipids, amino acid residues, and sulphhydryl groups and thus becomes reactive and toxic. It affects the plasma membranes by depolymerising proteins and altering surface antigens.
 - b. Acetaldehyde binds to tubulin and impairs the microtubules of the cytoskeleton.

Other Mechanisms of Liver Injury by Alcohol Include

1. Changes in the intracellular redox potential
2. Mitochondrial swelling
3. Liver cell water and protein retention
4. Hypermetabolic state
5. Increased liver fat
6. Immunological liver damage
7. Fibrosis
8. Cytokine mediated injury.

Morphological Change

1. *Fatty liver*: Fatty liver is defined as the presence of more than 5 gm of fat/100 gm of liver tissue. The fat may be in the macrovesicular form (large droplet). In the more severely affected conditions, fatty change is diffuse (usually fat accumulates in zones 3 and 2).
2. *Alcoholic hepatitis*
 - a. Liver cell damage (typical ballooning degeneration and areas of necrosis).
 - b. Predominant neutrophilic infiltration.
 - c. Both pericellular (chicken wire appearance) and perivenular fibrosis.



The prominent features of alcohol hepatitis is the Mallory body or Mallory hyaline (also seen in primary biliary cirrhosis, Wilson's disease and drug intake-amiodarone).

3. *Cirrhosis*: Cirrhosis in alcoholics is of micronodular type. The formation of the nodules is often slow, because of a presumed inhibitory effect of alcohol on hepatic regeneration.

Clinical Syndromes

Fatty Liver

- a. The patients are usually asymptomatic, the diagnosis being made when an enlarged, smooth, firm liver is present.
- b. Nausea and vomiting with periumbilical, epigastric or right upper quadrant pain with jaundice are present in severe fatty liver.

Lab Features

- a. Hyperbilirubinaemia
- b. AST/ALT > 2 in 80% of the cases (high ratio is due to pyridoxine deficiency)
- c. Alkaline phosphatase is elevated (less than 300 IU/dl) in the absence of cholestasis.
- d. GGT/Alkaline phosphatase ratio is 5 or higher in 50% cases
- e. Blood levels of GGT more than 30 U and carbohydrate deficient transferrin more than 20 U are useful serological markers of heavy drinking (specificity and sensitivity > 70%). These tests are also useful in monitoring abstinence.
- f. Other blood tests that can be useful in identifying individuals consuming 6 or more standard drinks/day include – increased MCV (>91) and serum uric acid (> 7 mg/dl).

Acute Alcohol Hepatitis

- a. The usual symptoms are anorexia, nausea, malaise, weakness, vague abdominal pain, icterus, weight loss, or fever.
- b. The physical signs are
 - Hepatomegaly (95%)
 - Hepatic tenderness (50–60%)
 - Signs of portal hypertension (40–70%)
 - Stigmata of chronic liver disease and alcoholism (30–60%)
 - Jaundice (55%)
 - Fever (50%)
 - Upper GI bleeding (30%) and evidence for hepatic encephalopathy.

Lab Features

- a. Hyperbilirubinaemia
- b. Transaminases (AST, ALT) are elevated
- c. Prothrombin time is prolonged.

Hepatic Cirrhosis

- a. It may be asymptomatic 10–20% of patients but commonly presents with complications and stigmata of chronic liver disease
- b. Hypogonadism and feminization are common in male cirrhotic patients.

Lab Features

- a. Transaminases are increased
- b. Hypoalbuminaemia
- c. Prothrombin time is prolonged
- d. The other features are leukopenia, thrombocytopenia and anaemia
- e. Liver biopsy and ultrasound are essential for diagnosis.

Prognosis

The levels of prothrombin time and bilirubin are used to determine the discriminant function, which estimates prognosis in alcoholic hepatitis.

Discriminant Function = $4.6 \times \text{Increased PT (sec)} + \text{Serum Bilirubin (mg)}$

A Value of > 32 is bad.



Treatment

The pathogenic mechanisms in alcoholic hepatitis involve cytokine release – TNF and the perpetuation of injury by immunological processes. Therefore, patients with severe alcoholic hepatitis defined as discrimination factor > 32 can be tried with steroids – Prednisone 40 mg/day (immuno-suppressive effect) for four weeks and then taper or Pentoxifylline.

1. Abstinence from alcohol (total and immediate).
2. Dietary supplementation (proteins and vitamins and electrolytes).
3. Avoid precipitating factors (infection, bleeding).
4. Treatment of withdrawal syndrome.
5. Treatment of complications (ascites, spontaneous bacterial peritonitis, hepatorenal syndrome, hepatic encephalopathy, upper GI bleeding).
6. Hepatic transplantation is indicated in selected cases of acute alcoholic hepatitis and alcoholic cirrhosis.

Alcohol and Central Nervous System (CNS)

1. Acute Intoxication

Ethanol is a CNS depressant. It directly and indirectly interferes with gamma aminobutyric acid receptor function and predominantly affects frontal cortical control. The CNS changes occur at lower blood levels in the case of females and occasional alcoholics and higher levels in the case of chronic alcoholics (Fig. 13.1).

CNS Symptoms and Levels of Ethanol in Blood

1. Euphoria (25–50 mg/dl)
2. In-coordination (50–100 mg/dl)
3. Ataxia (100–200 mg/dl)
4. Stupor (200–400 mg/dl)
5. Coma (400–900 mg/dl).

2. Alcoholic Coma

It is a serious disorder and occurs in 5% of hospital admission. The inhalation of the vomitus is frequently fatal due to anoxaemia from acute distress (Mendelson's syndrome).

3. Withdrawal Syndrome

This syndrome is present in chronic alcoholism (regular basis for 5–10 years) with evidence of dependence.

The features are anxiousness, tremulousness and irritability, shakes or jitters, nausea, vomiting and more specifically nightmares, night terrors or blackouts. The syndrome occurs after a period of abstinence (12–36 hrs). It also causes alcohol withdrawal fits (rum fits). These fits do not produce EEG changes, and are treated with chlordiazepoxide and carbamazepine. The conventional anticonvulsants are less effective.

4. Alcohol Dementia

It is due to excessive alcohol intake. The clinical feature is mild to diffuse global dementia due to atrophy of the cerebral cortex and enlargement of the ventricles. The other features are antisocial behaviour, dysarthric speech, tremor, ataxic gait and peripheral neuropathy. It is not due to thiamine deficiency.



Treatment

- a. Withdrawal of alcohol
- b. Multivitamin replacement.

5. Marchiafava-Bignami Syndrome

It is described in Italian drinkers of crude red wine and other alcoholics. It presents as a subacute dementing illness, and later progresses rapidly to fits, rigidity, paralysis, coma and death. It is due to demyelination and axonal damage in the corpus callosum, cerebral white matter, optic chiasma and middle cerebellar peduncle.

6. Cerebrovascular Disease

Consumption of large quantity of alcohol is the most common cause of stroke in the young. It also increases the risk of stroke in people of all ages. CVA is much more likely to occur after a binge of alcohol consumption. The increased risk of stroke is thought to be due to factors like increased viscosity of blood, coagulation defects and dysrhythmias. The possible consequences of high alcohol consumption are intracerebral haemorrhage, cerebral infarction, or subarachnoid haemorrhage. Alcoholics are also prone to develop subdural haematoma as a consequence to head injury while in an intoxicated state.

7. Alcoholic Cerebellar Degeneration

It is due to degeneration of cerebellar cortex (Purkinje cells) and superior and anterior part of the vermis.

The clinical features are ataxia, progressive unsteadiness of gait with more involvement of the lower limbs than the upper limbs. There is no speech disturbance or nystagmus.

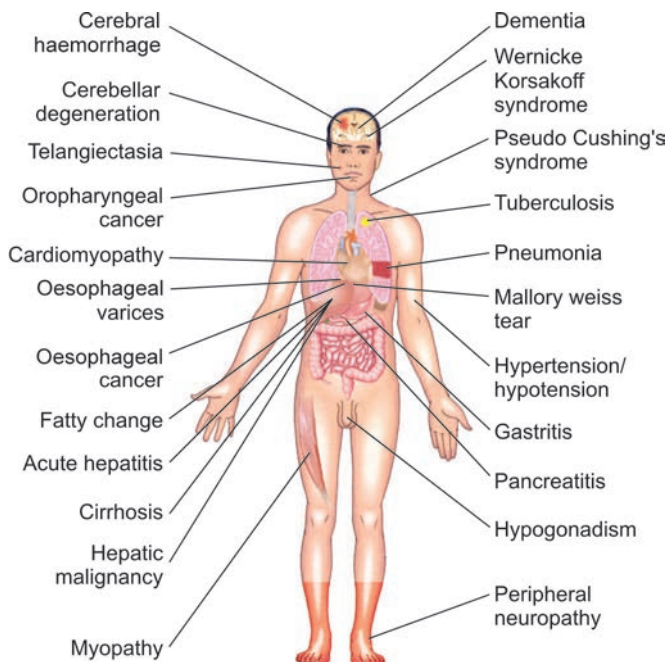

Fig. 13.1: Ill-effects of alcohol



8. Central Pontine Myelinosis

It is a rare disorder occurring in alcoholics and a number of other disorders (liver, renal, metabolic disorders). It is characterised by rapid onset of flaccid or spastic quadriplegia with involvement of bulbar muscles (dysarthria, dysphagia).

9. Peripheral Neuropathy

It is due to predominant axonal neuropathy of the dying back type, affecting the somatic and autonomic nervous system.

The clinical features are distal paresthesia (in the feet and hands), weakness and wasting of the distal muscles (legs and arms) and loss of DTR. The ANS features are abnormal pupillary reaction, tachycardia and orthostatic hypotension.

10. Saturday Night Palsy

This is a condition whereby there is compression trauma to the radial nerve in the radial groove leading to wrist and finger drop. This is a consequence of an alcoholic binge over the weekend (Saturday) and abnormal posturing of the arm during the stuporous state of alcohol intoxication. This palsy usually recovers within 8–12 weeks with conservative management.

11. Alcoholic Myopathy

It is characterised by severe muscle pain and tenderness, myoglobinuria and renal damage with hyperkalaemia. It is due to direct effect on muscle.

Tobacco Alcohol Amblyopia

It is an uncommon complication of alcoholics. It is characterised by sudden or subacute bilateral visual failure with bilateral centrocaecal scotomas.

Nutritional Deficiency Syndrome

a. Wernicke-Korsakoff Syndrome (Confabulation Psychosis)

It is characterised by a triad of ophthalmoplegia (nystagmus and impaired ocular abduction), cerebellar ataxia, and confusional state. The other clinical features are lethargy, inattentiveness, disorientation (to place, person, and time) and loss of recent memory and altered consciousness. The gaps in memory are filled in by imaginary and often graphic accounts of events (confabulation).

It is due to inadequate intake of thiamine. The pathological changes are hyperemia with multiple small

haemorrhages in the upper brainstem, hypothalamus, thalamus adjacent to third ventricle and the mamillary bodies.

b. Pellagra

It is characterised by diarrhoea, dementia and dermatitis.

Pregnancy and Alcohol

Foetal Alcohol Syndrome

Maternal alcohol consumption in the first four weeks of conception is teratogenic and it manifests as craniofacial abnormalities (micro-ophthalmia, elongated mid-face, longer upper lip with poorly developed philtrum) and CNS abnormalities in the foetus (intellectual impairment and developmental delay). Alcohol consumption in the later stage of pregnancy results in intellectual deficit, auditory and visual deficits, and hyperkinetic syndromes in the offspring.

Other defects noted are VSD or ASD, aberrant palmar crease and limitation of joint movement.

It is due to acetaldehyde formation in the placenta. The predisposing factors are PEM, vitamin deficiency and zinc deficiency and synergism with heavy tobacco usage.

Gastrointestinal

Oesophagus

1. Oesophagitis
2. Mallory-Weiss syndrome: It is characterised by longitudinal tear in the mucosa at gastro-oesophageal junction in chronic heavy drinkers during violent vomiting.

Stomach

1. Gastritis
2. Peptic ulcer
3. The clinical features are epigastric pain, nausea, and vomiting.

Pancreas

1. Acute pancreatitis
2. Chronic pancreatitis
3. Pseudopancreatic cyst
4. Pancreatic carcinoma.

Small Bowel

1. It interferes with absorption of B-vitamins and nutrients.

2. It also produces haemorrhagic lesions of the duodenal villi.
3. The clinical features are diarrhoea (secondary to increased small bowel motility) and electrolyte imbalance.

Haematology

It manifests as a reversible acute and chronic disorder of blood cells.

1. *RBCs*: Macrocytic anaemia, hypersegmented neutrophils, reticulocytopenia and hyperplastic bone marrow.
2. *WBCs*: Decreased granulocyte mobility and adherence with hypersegmentation.
It impairs the delayed hypersensitivity response to newer antigens.
It produces toxic granulocytosis.
3. *Platelets*: Mild thrombocytopenia, hypersplenism (cirrhosis), decrease in platelet aggregation and inhibition of release of thromboxane can occur.

Cardiovascular System

It reduces the myocardial contractility and causes peripheral vasodilatation.

One or two drinks/day over long periods may increase HDL cholesterol. But three or more drinks/day result in dose dependent increase in BP (it returns to normal within a week of abstinence).

Chronic heavy drinking manifests as cardiomyopathy (unexplained arrhythmia in the presence of LV impairment) and mural thrombi in LA and LV.

Holiday Heart Syndrome

The development of atrial or ventricular arrhythmias occurs after a binge in individuals showing no other evidence of heart disease.

Respiratory System

Alcohol consumption may exacerbate bronchial asthma (particularly by red wine).

Genitourinary System

Modest alcohol dose (blood alcohol level is 100 mg/dl or even less) intake manifests as increased sexual drive, decrease in erectile capacity and testicular atrophy, shrinkage of the seminiferous tubules and loss of sperms. In women, it manifests as amenorrhoea, (due to decrease

in ovarian size and absence of corpora lutea) and abortion. Acute urinary retention may occur after a bout of heavy alcohol consumption.

Bone

Alcohol intake manifests as fracture (due to alteration of calcium metabolism) and osteonecrosis of femoral head.

Endocrine

1. It manifests as hypoglycaemia and hyperglycaemia (in heavy alcohol drinking)
2. Reversible decrease in serum thyroxine (T_4 and T_3).

Skin

1. Psoriasis
2. Discoid eczema
3. Rosacea
4. Low grade bacterial and fungal skin infections.

Alcohol and Malignancy

Alcohol consumption predisposes to development of following malignancies:

1. Carcinoma of liver
2. Carcinoma of oral cavity
3. Carcinoma of pharynx
4. Carcinoma of larynx
5. Carcinoma of oesophagus
6. Carcinoma of pancreas
7. Carcinoma of breast.

Alcohol and Lymphatic System

There is lower risk of developing lymphoma in alcoholics.

Alcohol consumption may cause pain at site of lymph node or extra lymphatic involvement in patients with Hodgkin's lymphoma.

Alcohol and Drug Interactions

1. *Sedatives*: The sedative effects of alcohol are increased by concurrent intake of sedatives, hypnotic, or opioid drugs. There is gross impairment of psychomotor function.
2. *Antihypertensive drugs (vasodilators)*: The vasodilator effect of ethanol is exaggerated with concurrent



- intake of vasodilator antihypertensive agents, leading to risk of postural hypotension.
3. *Aspirin and other NSAIDs*: Incidence of gastric irritation and upper GI bleed is increased with concurrent intake of alcohol and NSAIDs.
 4. *Insulin*: There is an increased risk of developing severe hypoglycaemia in diabetic patient on insulin when there is an excessive intake of alcohol.
 5. *Monoamine oxidase inhibitors*: Some alcoholic drinks contain tyramine and so there may be a risk of developing severe hypertension in patients taking MAO inhibitors and consuming alcohol.
 6. *Oral contraceptives*: Women taking oral contraceptives eliminate alcohol slowly and so the effect of alcohol is prolonged.
 7. *Metronidazole, chloral hydrate and disulfiram*: These drugs inhibit aldehyde dehydrogenase activity and lead to accumulation of acetaldehyde. When alcohol is also consumed along with any one of these drugs, the level of acetaldehyde rises markedly leading to facial flushing, tachycardia, hypotension, dyspnoea, nausea and vomiting.
 8. *Warfarin*: Acute alcohol intoxication potentiates the hypoprothrombinaemic effect of warfarin leading to bleeding tendencies.

Psychological

1. Anxiety
2. Depression
3. Personality change
4. Misuse of other drugs
5. Cognitive impairment.

Social

1. Family problems, marital discord
2. Financial problems
3. Repeated road traffic accidents, driving offences
4. Employment (e.g. absenteeism, especially on Monday, poor performance)
5. Sexual abuse.

Alcoholic Coma

- At levels > 400 mg/dL—respiratory depression and coma.
- Insert endo-tracheal tube before gastric lavage (<1 hour after ingestion)
- Charcoal is not helpful since alcohol is rapidly absorbed.
- 100 mg of thiamine IV followed by 50 mL 50% dextrose in water IV.

- Haemodialysis may be useful for life-threatening overdoses.
- Consider additional toxicology testing and head CT.

Alcohol Withdrawal

- Interruption of alcohol following illness or hospitalisation
- *Minor symptoms*—Tremulousness, irritability, anorexia and nausea
 - It occurs within a few hours after cessation of drinking and resolve within 48 hours.
 - i. Thiamine 100 mg IM followed by 100 mg PO daily
 - ii. Multivitamins containing folic acid and balanced diet
 - iii. Chlordiazepoxide 25-100 mg tid
- *Alcohol withdrawal seizures*—Convulsions occur within 12-48 hours after cessation of drinking. Anticonvulsants are not indicated since this is self-limited. Thiamine should be given prior to glucose while correcting hypoglycaemia. Consider other causes for seizure.
- *Severe withdrawal symptoms*—Delirium tremens, hallucinations, agitation, confusion, and autonomic hyperactivity (fever, tachycardia, and diaphoresis)
 - It typically occurs 3-4 days after cessation of drinking. Symptoms usually resolve in 3-5 days.
 - i. Chlordiazepoxide—100 mg IV or PO qid (maximum 500 mg in 1st 24 hours.)
 - Give one-half of the dose on the 2nd day and reduce the dose by 50 mg/day each day thereafter. Use short acting lorazepam 1-2 mg PO or IV in elderly patients. In patients with hepatic failure, oxazepam 15-30 mg PO tid or as needed which is excreted by the kidney instead of chlordiazepoxide.
 - ii. Correct hypoglycaemia, hypokalaemia, hypomagnesaemia and fluid losses.
 - iii. Atenolol, clonidine, carbamazepine, and haloperidol are some of the other drugs used in the management of alcohol withdrawal syndrome.

Smoking

Cigarette smoke is a heterogenous aerosol produced by incomplete combustion of tobacco leaf. On an average, smokers lose more than one day of life every week.

Main stream smoke: Smoke emerging from mouth-piece during puffing

Side stream smoke: Smoke emitted between puffs at the burning cone and from the mouthpiece

Side stream smoke contains more of particulate matter especially carcinogens.

Contents of Cigarette Smoke

Carcinogens	Tar Polynuclear aromatic hydrocarbons β -naphthylamine N-nitrosornicotine Benzopyrene Trace metals—nickel, arsenic, polonium 210 Nitrosamines, hydrazine, vinyl-chloride
Co-carcinogens	Phenol, cresol, catechol
Tumour accelerator	Indole, carbazole

Pharmacology of Cigarette Smoke

There are more than 4000 substances identified in cigarette smoke. They have antigenic, cytotoxic, mutagenic and carcinogenic properties.

Nicotine is a toxic alkaloid present in cigarette smoke which is both a ganglionic stimulant and a depressant.

Acute cardiovascular effects of nicotine are increase in

- both systolic and diastolic BP
- heart rate
- force of myocardial contraction and excitability
- myocardial oxygen consumption
- coronary artery blood flow
- peripheral vasoconstriction.

Major carcinogens found in cigarette smoke are polynuclear aromatic hydrocarbons, aromatic amines and nitrosamines. Co-carcinogens like catechol enhance the carcinogenicity.

Carbon monoxide is a toxic gas found in smoke (2-6%) and causes polycythaemia and CNS impairment. This is the major cause for COPD.

Smoking also causes chronic cough, sputum, dyspnoea, change in lung function tests, increase in incidence of pneumonia and inflammatory lung disease.

Characteristics of Smokers

Smokers drink more alcohol, coffee and tea than non-smokers. Menopause comes earlier in smoking women. Smokers have impaired exercise performance, impaired immune system compared to non-smokers. They show increase in hematocrit, WBC count and platelet count, there is decrease in leucocyte vitamin C levels, serum uric acid and albumin in smokers.

The ratio of HDL to LDL cholesterol is also reduced.

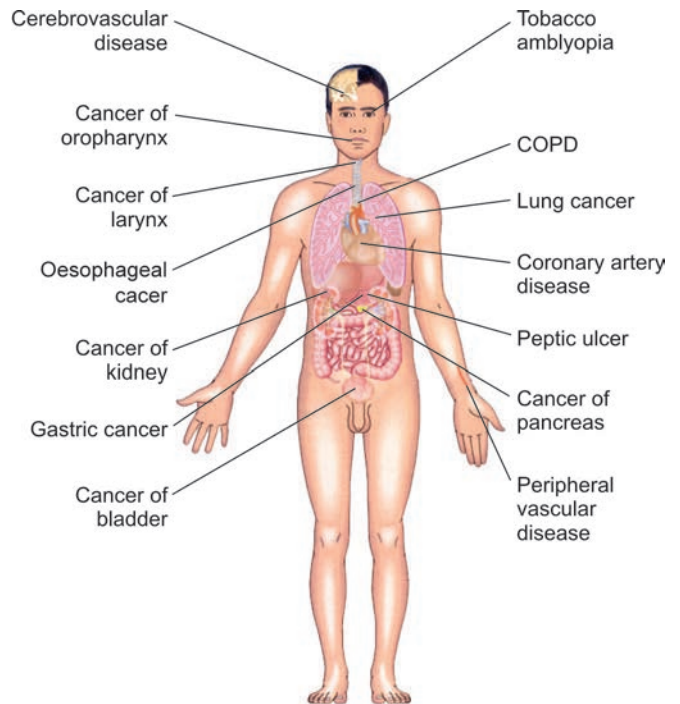

Fig. 13.2: Ill-effects of smoking

Clinical Correlations

Common disorders associated with smoking include atherosclerotic cardiovascular disease, cancer and COPD. The risk is dependent on duration, intensity and type of smoke exposure (Fig. 13.2).

Smoking and Cardiovascular Disease

- Smoking, hypertension, and hypercholesterolaemia are three major risk factors for coronary heart disease (CHD). Presence of two out of the three risk factors may produce a 4-fold increase in CHD risk and 3 risk factors produces a 8-fold increase in CHD risk.
- CHD death rates are 60–70% greater in male smokers than in non-smokers.
- Sudden death is 2–4 times more common in young male smokers.
- Women smokers also develop CHD especially when they take oral contraceptive pill also.
- Those who continue to smoke after acute MI are most likely to die from CHD than those who quit smoking. Smokers have an increased perioperative mortality than non-smokers.
- Similarly, cerebrovascular disease and stroke is also common in smokers. In women smokers, subarachnoid haemorrhage is more common; oral contraceptives increase the risk in them.



- Peripheral vascular diseases like thromboangiitis obliterans (TAO) and arteriosclerosis obliterans are common in smokers.
- Hypertensives who smoke are at a greater risk of developing malignant hypertension and they die from complications of hypertension.

Smoking and Cancer

Smoking causes cancer of

Oral cavity	Pancreas
Larynx	Kidney
Lung	Urinary bladder
Oesophagus	Uterine cervix
Stomach	Myelocytic leukaemia

Smoking Index (SI)

SI = number of cigarette/day × total duration in years

SI < 100 Mild smoker

SI 101–300 Moderate smoker

SI > 300 Heavy smoker

Lung cancer is common if smoking index is more than 300.

Pack Year

No. of pack years = 1 packet of cigarette/day × number of years (one pack = 20 cigarettes).

The risk of developing lung cancer is 40 times more in patients who smoke 2 packs per day for 20 years.

Smoking and Respiratory Disease

Male smokers have 4-25 times higher mortality secondary to COPD than non-smokers.

Prolonged cigarette smoking impairs ciliary movement, inhibits function of alveolar macrophages and leads to hypertrophy and hyperplasia of mucus secreting glands. It also inhibits antiproteases and causes polymorphs to release proteolytic enzymes acutely. The inhaled cigarette smoke increases airway resistance due to vagally mediated smooth muscle constriction by way of stimulating submucosal irritant receptors.

Abnormalities in pulmonary function tests, (measurements of elastic recoil, airflow in large and small airways and diffusing capacity) is common in smokers. There is increase in incidence of respiratory infections and deaths due to pneumonia and influenza. Post-operative respiratory complications, spontaneous pneumothorax are also common. Chronic pharyngitis, chronic laryngitis and chronic bronchitis occur more frequently in smokers.

Smoking and Gastrointestinal Disorders

In smokers, there are changes in hard and soft tissues of the mouth, discolouration of the teeth and there is decreased sensation of taste and smell.

Gastric, and duodenal ulcer disease is more prevalent in smokers both in males and females. Smoking impairs ulcer healing, favours recurrence of ulcers, inhibits pancreatic HCO_3^- secretion and decreases the pressure of oesophageal and pyloric sphincters. Inhibition of nocturnal acid secretion by H_2 blockers is also prevented by smoking.

Smoking and Depression

Prevalence of smoking is increased in those who have a major depressive disorder.

Smoking and Body Weight

There is an inverse association between smoking and body weight. Weight gain occurs after cessation of smoking.

Smoking and Pregnancy

Smoking delays conception and smoking during pregnancy affects the foetus. Babies born to mothers who smoke have a weight of about 170 gm less than the babies born to non-smokers. This is due to impaired uteroplacental circulation.

Spontaneous abortion, foetal death, neonatal death and sudden infant death syndromes are also common. The long-term physical growth and intellectual development of the child is also affected.

Passive Smoking

Since side stream smoke is diluted in a large volume of air, smoke exposure from involuntary inhalation is less than that associated with smoking.

Passive smoking is one of the causes for lung cancer in non-smokers. Parental smoking is a cause for middle ear effusions, acute or chronic respiratory illness and asthma in children. Passive smoking may also cause coronary heart disease.

Smoking and Drugs

Tobacco smoke constituents induce hepatic microsomal enzyme systems which are important in the metabolism of drugs like propranolol, theophylline and propoxyphene and hence increase in dose in smokers is recommended.

Interaction of Smoking and Drugs

Benzodiazepines	Less sedation
Beta blockers	Reduced effect due to increased 1st pass clearance
Imipramine	Decreased serum concentration
Chlorpromazine	Decreased serum concentration
Clomipramine	Decreased serum concentration
Clozapine	Decreased serum concentration
Haloperidol	Decreased serum concentration
Oral oestrogens	Increased hepatic clearance
Heparin	Faster clearance
Insulin	Delayed absorption due to cutaneous vasoconstriction
Theophylline	Faster metabolic clearance

Types of Smoking

- Using low tar-nicotine cigarettes shows decrease in risk of developing lung and laryngeal cancers. The risk is the same for both high tar-nicotine cigarettes and low tar-nicotine cigarettes when the number of cigarettes smoked per day and the duration of smoking are more in the latter group.
- Using pipe, or cigar reduces the overall risk (the patients do not inhale more smoke since the alkaline pH of tobacco used in them is a potent irritant of respiratory tract).
- Death rates of cigar, pipe and cigarette smokers are more or less the same as far as carcinoma of oral cavity, larynx and oesophagus are concerned. Otherwise there are more adverse health regarding cancer at other sites, CHD or COPD.
- Chewing tobacco or using snuff produces increased risk for oral cancers.
- Cessation of smoking produces immediate and long-term physical, psychological and economic benefits. The sense of smell and taste may improve within a few days of quitting the cigarette.
- One year after stopping, there is a decrease in risk for CHD; cessation also decrease risk for tobacco related cancers, cerebrovascular disease, MI, and COPD.

Cessation Process

Smokers should stop smoking in a step-wise process. First they think about quitting, then they decide to quit and later they should maintain an ex-smoker status.

Most successful quitters relapse and recycle through these stages 3–4 times before abstinence. Factors encouraging long-term cessation include decreased social acceptability, increased concern about health consequences and increased cost of tobacco.

Cessation Methods

Counselling, group therapy, behavioural training, hypnosis, and acupuncture are the methods tried.

Quitting 'cold turkey' is the method used by 80% of smokers.

Pharmacotherapy

1. Nicotine containing chewing gum 2 or 4 mg chewed over 20-30 minutes, repeated upto 60 mg/day.
2. Transdermal nicotine patch; started as high dose patch, 21 mg/day for 6 weeks followed by intermediate dose patch, 14 mg/day for 2-4 weeks followed by low dose patch, 7mg/day for 2-4 weeks.
3. Nicotine nasal spray; 2 sprays (equivalent to 1 mg) as needed not to exceed 5 doses/hr or 40 doses/day.
4. Nicotine inhalor; 6-16 cartridges/day for 12 weeks followed by tapering over 6-12 weeks.

Each cartridge contains 10 mg of nicotine.

- Nicotine lozenges—2 mg every two hourly and not to exceed 20 lozenges in a day. Patients who smoke the first cigarette within 30 minutes of waking should use the 4 mg strength. Weaning process takes many weeks.
- Sublingual nicotine tablets—2 mg twice in one hour, do not exceed 80 mg/day (40 tablets).

Heavy smokers need combination therapy with long acting patch with short acting nicotine product. Nicotine therapy is for 3 months and subsequent tapering is done over a period of 6-12 weeks.

Contraindication:

- Significant vascular disease
- Pregnancy
- Breast feeding
- Allergy to the drug

Side effects:

- Headache
- Insomnia
- Nightmares
- Nausea and vomiting
- Dizziness
- Blurred vision
- Chewing gum – tingling sensation
- Transdermal patch – local redness and pruritus
- Nasal spray – sneezing, lacrimation and cough
- Nicotine inhaler – cough and oral irritation

5. Bupropion hydrochloride.

It acts by inhibiting neuronal reuptake of dopamine and nor-adrenaline. The drug is started 1 week before



quitting smoking at a dose of 150 mg orally OD for 3 days followed by 150 mg orally BD for 7-12 weeks, increases smoking cessation rate when used with behaviour modification programme and can be combined with nicotine replacement.

Side effects:

- Nausea and xerostomia
- Headache
- Hypertension
- Insomnia
- Dizziness
- Seizures

Contraindication:

Seizure disorder
 Eating disorder like bulimia or anorexia nervosa.
 Administration of MAO inhibitors
 Head trauma
 CNS tumour
 Concomitant antidepressants or antipsychotics
 Hypersensitivity
 Concomitant alcohol or benzodiazepines should be avoided.

6. Second line therapies:

- i. Clonidine—Initial dose 0.1 mg bid PO and increased to 0.15-0.75 mg/day PO or transdermal patch 0.1 to 0.2 mg for 3 to 10 weeks.

- ii. Nortriptyline 25 mg/day and increased up to 100 mg/day PO for 12 weeks.

7. Varenicline (Chantix)

Start one week before quitting smoking, 0.5 mg PO daily for 3 days, 0.5 mg bid for the next 4 days, and subsequently 1 mg bid for 12 weeks. It binds to nicotine receptors and blocks their activation by nicotine. It prevents smoking induced reinforcement and reward.

Contraindications:

- Pregnancy
- Breast feeding
- Renal failure

Side effects:

- Nausea and vomiting
- Insomnia
- Nightmares
- Gingival pain, aphthous stomatitis
- Chest pain
- Cardiac arrhythmia
- Hypertension
- Myocardial infarction
- Tremor, in-coordination,
- Visual disturbances
- Muscle spasm and arthralgia
- Rarely suicidal tendency.

Chapter 14

Imaging Modalities in Internal Medicine

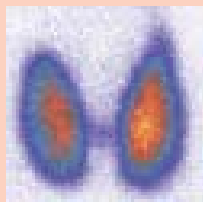

RESPIRATORY SYSTEM

CXR



Initial choice
picks up early lesions

CT



Imaging the hila/
mediastinum/pleura
HRCT-Bronchiectasis/ILD
Biopsies

PULMONARY ANGIOGRAPHY



Pulmonary vascular
disease
PHT/embolism

VP SCAN



PE

CARDIOVASCULAR SYSTEM

CXR



Initial choice
Cardiac enlargement
Valve calcifications

ECHO



Valvular/congenital
heart diseases
Quantification of LV function
clots/vegetations/effusions

ANGIOGRAM



CAD-diagnostic/therapeutic
Assessing the severity of
valvular/cong. heart disease

MR ANGIOGRAPHY



Angiography
Aortic diseases

NUCLEAR IMAGING



Assessing regional
myocardial blood flow
and cellular integrity of myocytes

NEUROLOGY

CT

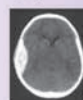

CVA -initial choice
Tumours/abscesses
Traumatic conditions

MRI



Posterior fossa lesions
Spinal cord lesions
White matter lesions

X-RAY



Calcifications
Bony abnormalities

ABDOMEN

X-RAY



Acute abdomen
free intraperitoneal gas
dilated bowel/fluid levels

ULTRASOUND



Studying liver/spleen/
kidneys/ovaries/prostate
obstetric study

CT



Detailed study of masses
retroperitoneal structure

CONTRAST STUDIES (oral/IV)



To study intraluminal
pathology-stone/neoplasms
strictures/ulcers/hernia, etc.

MRCP



Noninvasive way to
investigate hepatobiliary and
pancreatic disorders

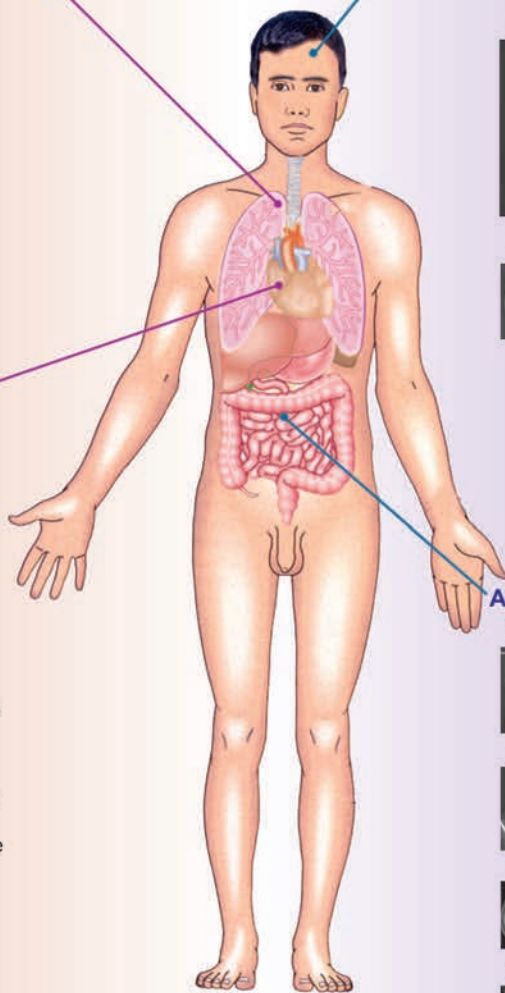



The Chest Film

The chest film is the mirror for many systemic disorders in addition to the information it reveals for respiratory and cardiovascular disorders. It normally shows anterior portion of 6 ± 1 ribs and posterior portion of 9 ± 1 ribs. More ribs/intercostals spaces can be seen in COPD, bronchial asthma and emphysema.

The right hemi-diaphragm is higher than the left diaphragm by 3 cm in 95% of cases. This apparent elevation of the right diaphragm (not due to liver) is due to the downward displacement of the left side of diaphragm by the heart. The lateral costo-phrenic angles should be sharp and acute.

This angle is blunted or ill-defined in pleural effusion or hyperinflation. The cardio-thoracic ratio is the ratio of heart width to the chest width. It should be less than 50% in PA view since the heart is magnified in AP view.

The left hilum is higher than the right by 1 cm. The density is equal. Change in density denotes rotated film or tumour or lymph nodes.

Lateral views are useful to study the segment of the lung fields affected and also to note the cardiac chamber hypertrophy. The right hemi-diaphragm crosses through the heart shadow to the anterior chest wall and the left hemi-diaphragm ends at the posterior cardiac border in lateral views of the chest X-ray (Figs 14.1 to 14.3).

In left lateral view left ventricular hypertrophy is best visualised as it encroaches the spine and the right ventricular hypertrophy is well visualised as it encroaches the retro-sternal space. Barium swallow RAO view demonstrates the sickling effect of compression on oesophagus by the left atrium.

Comma shaped calcification of the aortic knuckle indicates atherosclerosis. Calcification of the ascending aorta is diagnostic of syphilis.

Increased translucency of lung fields:

1. Pneumothorax—Absent vascular marking with visible collapsed lung
2. Bullous change – emphysema
3. Pulmonary embolus – Westermark's sign
4. Hyperinflation in COPD
5. Pulmonary hypertension.

Abnormal opacities:

1. Consolidation: Opacity + Air bronchogram within it (Silhouette sign)
2. Collapse: Loss of volume causes shift of the normal landmarks (Mediastinum, Hila, Fissures, etc.)
3. Linear opacities: atelectasis, septal lines (Kerley B lines—interlobular lymphatics), tumour, lymphangitis carcinomatosis

4. Ring shadows: bronchiectasis, cavitating lesions, tumour, abscess, hydatid cyst, Pulmonary infarct (Triangular with a pleural base – Hampton's hump)
5. 'Coin' lesions: enormous conditions (always rule out tumour)

Rest of the details is dealt in depth in the Chapter on Respiratory System.

Plain Abdominal Film

In an emergency, plain X-ray of the abdomen is taken without prior preparation. Demonstration of gas underneath the diaphragm in the erect film denotes bowel perforation. Small bowel is recognised by its central position and valvulae conniventes which reach from one wall to other. Large bowel is peripheral in position with its haustration. Displacement of bowel denotes space occupying lesion (Tumour) or massive organomegaly (Figs 14.4 and 14.5).

Extra Luminal Gas

- In the liver or biliary system – gas forming infection, after ERCP, after passing stone
- In the genitourinary system – entero-vesical fistula, emphysematous pyelonephritis (Diagnostic of DM with *E. coli* infection)
- In the colonic wall—Pneumatosis coli/infective colitis
- In the sub-phrenic abscess.

Calcification in the Abdomen

- Egg-shell calcification in an aneurysm
- Calcified lymph nodes (TB – abdomen)
- Calculi gallbladder,
- Intrarenal or ureteric calculi,
- Pancreatic calculi (chronic pancreatitis)
- Uterus – myoma calcified, very rarely foetus
- Dermoid cyst which may contain teeth.

Soft Tissues

Note the kidney size (10-12 cm) and shape-parallel to the psoas line-length equal to 2-3.5 vertebral bodies (T12 to L2). The psoas lines are obliterated in retroperitoneal inflammation, haemorrhage or peritonitis.

Meteorism

Localised peritoneal inflammation can cause a localised ileus. It can be seen as a 'sentinel loop' of intra-luminal gas and can provide a clue to the site of pathology – such as cholecystitis, pancreatitis, appendicitis and diverticulitis. However, at times even localised infection can produce generalised ileus.



BRONCHOPULMONARY SEGMENTS

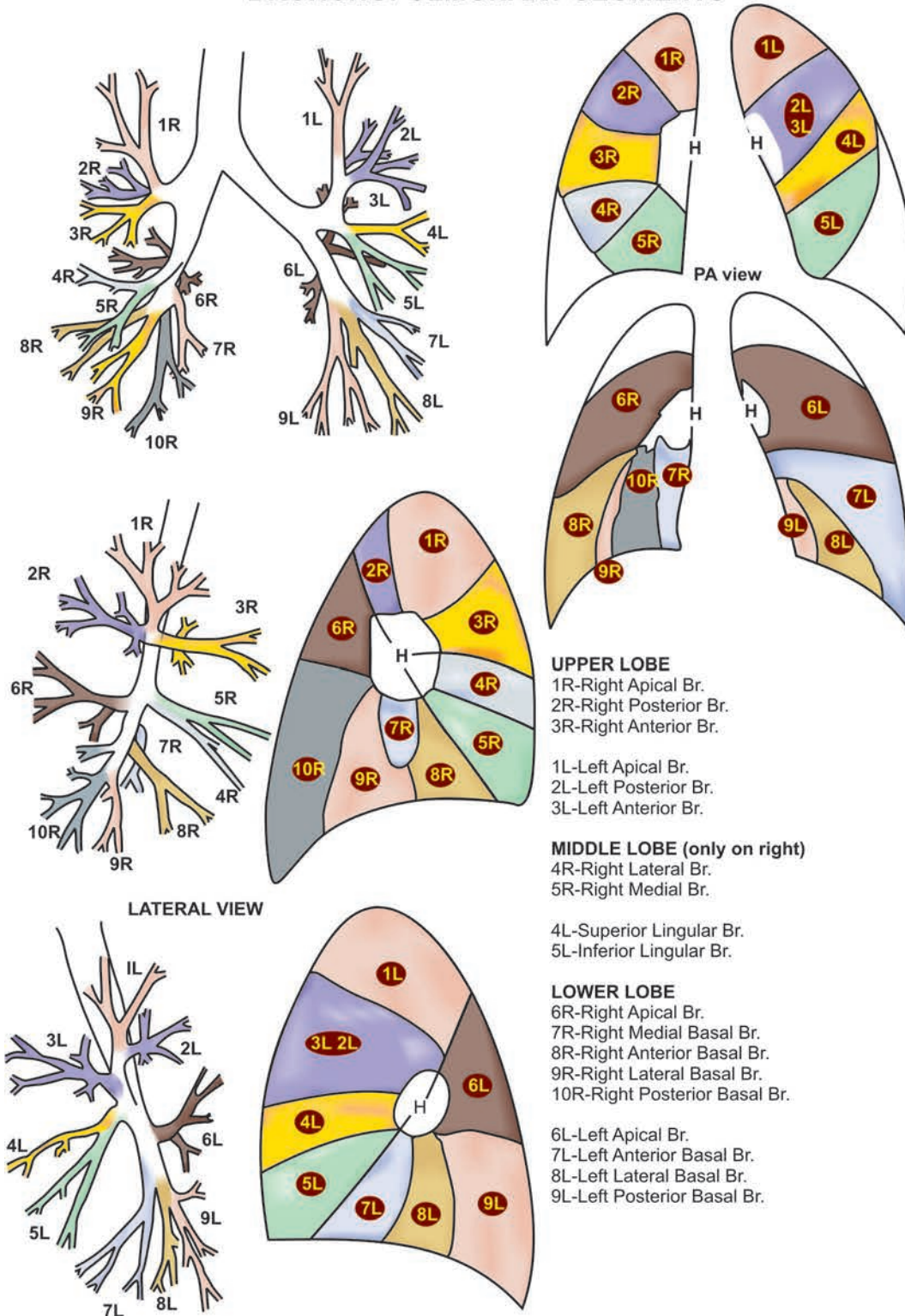

Note: Take PA and respective lateral view to localise the exact segment since segments overlap

Fig. 14.1: Positions of segments seen in chest X-rays

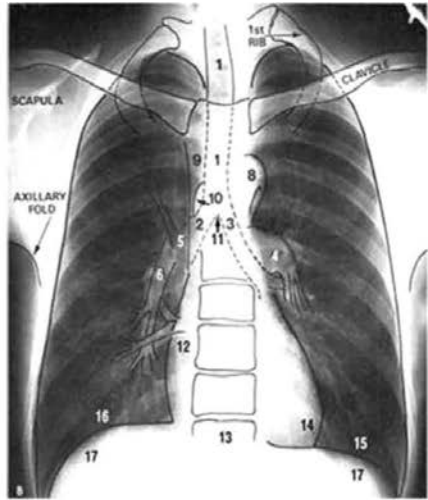

- TRACHEA (1)
- RIGHT MAIN BRONCHUS (2)
- LEFT MAIN BRONCHUS (3)
- PULMONARY ARTERIES (4,5 AND 6)
- RIGHT PULMONARY VEINS (7)
- AORTA (8)
- SUPERIOR VENA CAVA (9)
- ASCENDING AORTA (10)
- CARINA (11)
- RIGHT ATRIUM (12)
- VERTEBRA (13)
- CARDIAC APEX (14)
- RIGHT AND LEFT LUNG SHADOWS (16,15)
- RIGHT AND LEFT HEMIDIAPHRAGM (17)

CHEST X-RAYS SHOWING POSITION OF HEART CHAMBERS AND GREAT VESSELS

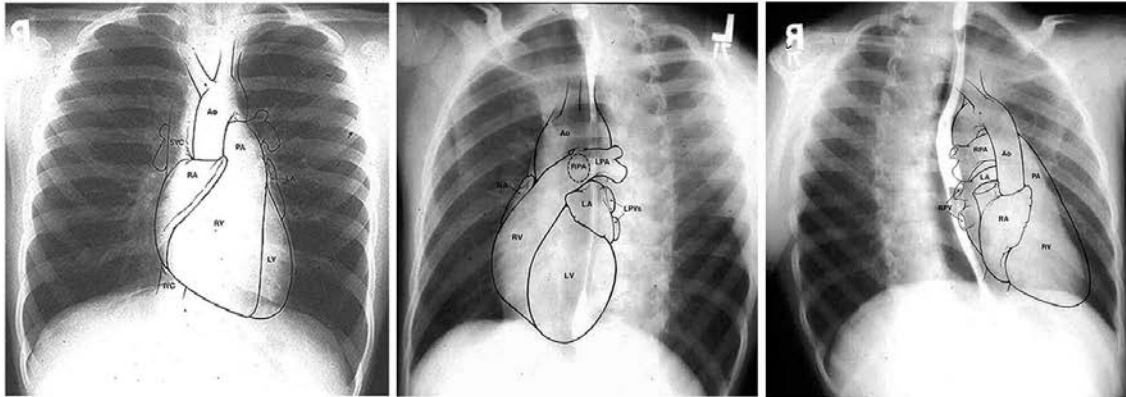

POSTEROANTERIOR VIEW

LEFT OBLIQUE VIEW

RIGHT OBLIQUE VIEW

METHODS OF MEASURING CARDIAC ENLARGEMENT

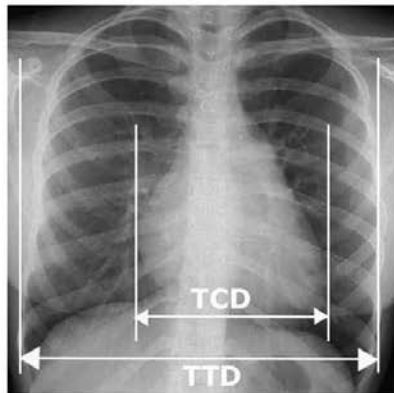

TCD > 50% OF TTD DENOTES CARDIOMEGALY

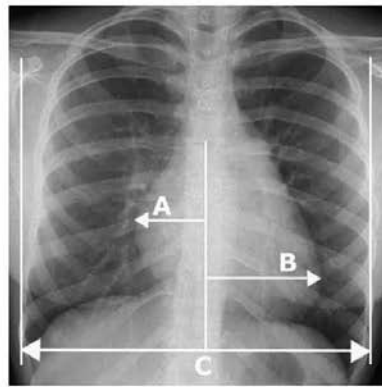

A+B > 50% OF C DENOTES CARDIOMEGALY

Fig. 14.2: Chest X-ray outlining the normal structures



Right pneumothorax with collapsed lung

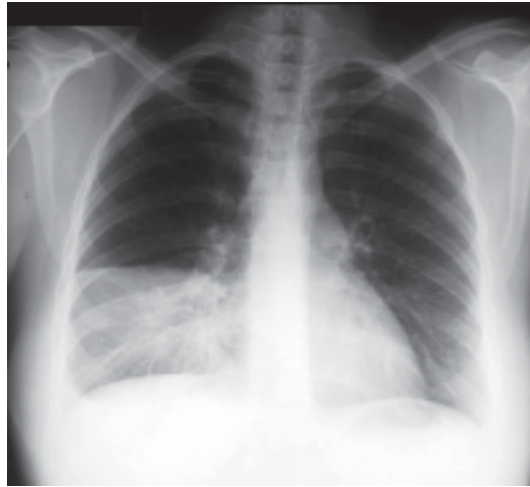

Lobar pneumonia—right middle lobe



Miliary tuberculosis



Lateral decubitus film demonstrating fluid level in pleural effusion



Mediastinal widening



Prosthetic valves (aortic and mitral)

Fig. 14.3: Chest X-rays

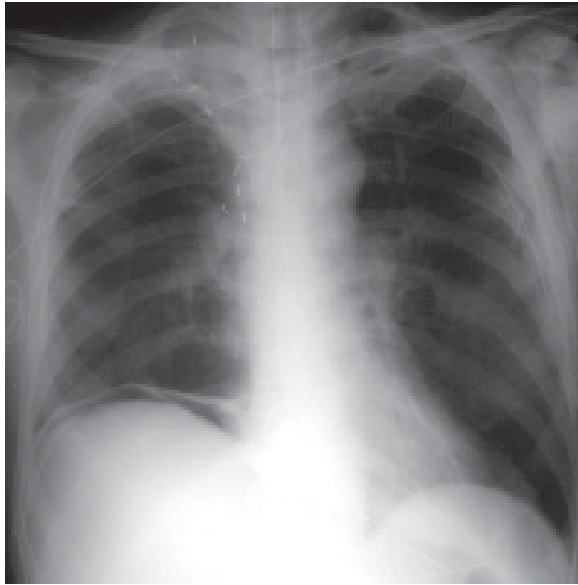

Air under diaphragm—perforation

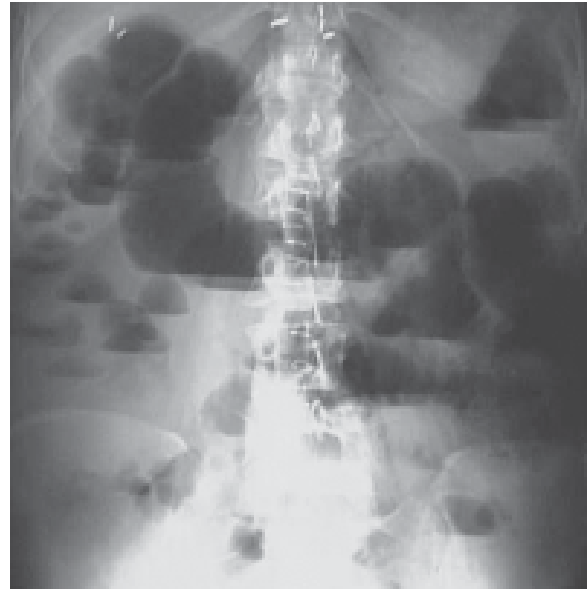

Intestinal obstruction (Multiple fluid levels)

Fig. 14.4

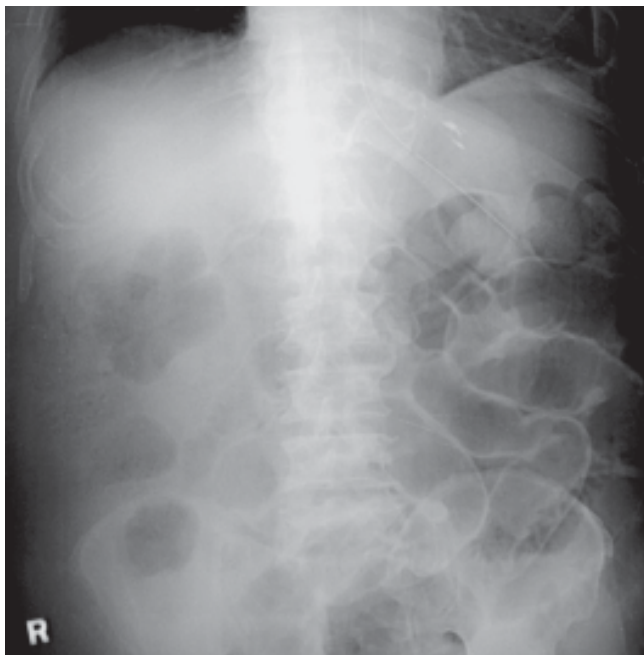

Pneumoperitoneum



Emphysematous pyelonephritis

Fig. 14.5

Figs 14.4 and 14.5: Abdomen plain X-rays

Spine and Pelvis

Look for degenerative changes (osteoarthritis), metastases (osteolytic/osteoblastic), collapse, looser zones (osteomalacia—'rugger-jersey' spine), Paget's disease (Figs 14.6 to 14.11).

Plain X-ray Skull (Fig. 14.12)

Look for the following:

- Linear skull fracture (Likelihood of intracranial haematoma—more frequent with unconscious patient than with conscious alert patient)

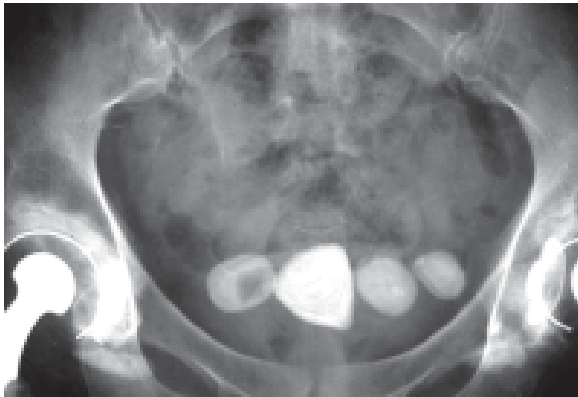

Fig. 14.6: Vesical calculi



Fig. 14.9: Rugger-Jersey spine



Fig. 14.7: Looser sone—pelvis



Fig. 14.10: Multiple metastases in pelvis



Fig. 14.8: Looser zone—femur

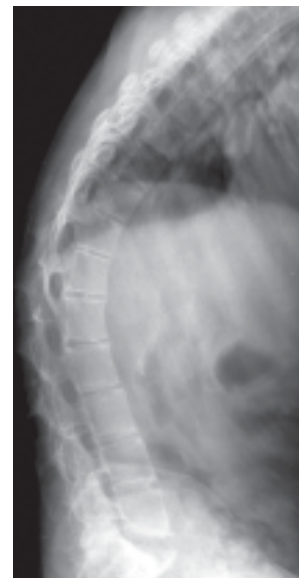
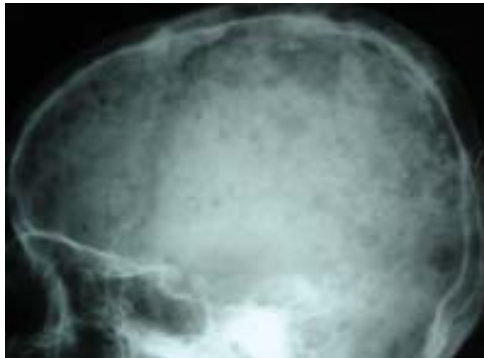
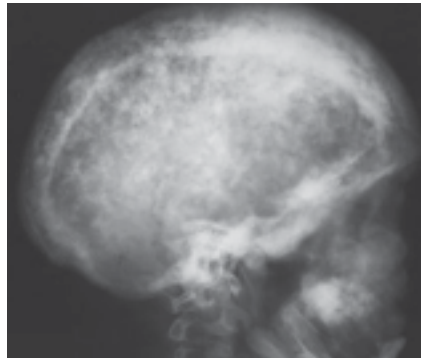

Fig. 14.11: Ankylosing spondylitis



Punched out lesions in skull—multiple myeloma



Paget's disease—skull

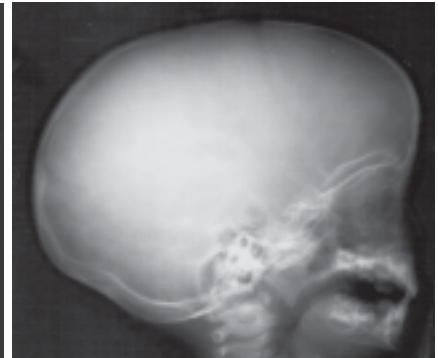

Hydrocephalus

Fig. 14.12: X-rays—skull

- Depressed skull fracture (needs elevation)
- Status of the cranio-cervical junction
- Shift of the calcified pineal body > 3 mm from midline
- Increase in vault density—Paget's disease, fluorosis, diffuse increase in thickness-acromegaly, thalassaemia
Localised increase in thickness – Paget's disease, meningioma, osteomyelitis, leukaemia, histiocytosis
- Luscant areas—multiple myeloma, Paget's (osteoporosis circumscripta), malignancy, hyperparathyroidism.

Intracranial Calcification

- Pineal body, gliomas, meningiomas, craniopharyngiomas
- Tram-line calcification—Sturge-Weber syndrome
- Ring calcification—cerebral aneurysm, TB, toxoplasmosis.

Sella Turcica

- Normal size—AP diameter 11-16 mm and depth 8-12 mm.
- Enlargement—pituitary adenoma
- Erosion of clinoids—raised ICT
- Erosion of lamina dura of dorsum sellae—tumour or aneurysm.

Air Sinuses

- Thickened mucosa—Chronic sinusitis
- Enlarged sinuses—Acromegaly
- Fluid level—after trauma (maxillary sinus-infraorbital fracture (●), Sphenoid sinus-fracture base of the skull).

X-ray Hands

Soft Tissues

- Generalised increase in thickness—Spade like hands in acromegaly, sausage digit in psoriatic arthropathy
- Soft tissue calcification—CREST – scleroderma, dermatomyositis
- Localised thickness – gout, pericapsular inflammation, soft tissue tophus in gout, rheumatoid nodules, Bouchard and Heberden nodes in osteoarthritis.

Joints

- Symmetrical peripheral small joints except DIP—Rheumatoid arthritis
- Pitting of nails with DIP and skin lesions—Psoriasis
- Osteoarthritis—DIP (Heberden's nodes)/PIP (Bouchard's nodes) with osteoporosis.

Deformities

- Ulnar deviation and subluxation—Rheumatoid arthritis – Swan neck, boutonniere deformity
- Look for syndactyly or polydactyly – Pulmonary stenosis/ASD/Laurence-Moon-Biedl syndrome
- Short metacarpals – Pseudo-hypoparathyroidism (Knuckle-Knuckle-Dimple-Dimple Syndrome), Pseudo-pseudo hypoparathyroidism Turner's syndrome.

Erosion of Terminal Phalangeal Tufts (Fig. 14.13)

- Seen in sarcoid, Hyperparathyroidism, Scleroderma with 'pseudoclubbing' and psoriasis.



Fig. 14.13: Renal osteodystrophy

Coarse Trabeculations

Chronic haemolytic anaemia, Paget's disease, Lipidoses—Gaucher's syndrome.

Middle Phalanx

Subperiosteal erosion along the radial border is an early sign of hyperparathyroidism.

Contrast Studies

They are performed either with an IV contrast or with an oral contrast such as barium or gastrograffin. IV contrast should be used with caution in renal failure patients and ensure good hydration and diuresis (IV fluids and Mannitol). IV contrast can result in anaphylaxis, bronchospasm, and pulmonary oedema. The newer non-ionic contrast agents are safer.

GI studies with contrast—barium swallow, barium meal, small bowel follow through, and colonic enema. Double contrast technique with air and barium is very useful to demonstrate surface mucosal pattern. The lesions are more well seen by distending the gut wall – tumour, diverticula, polyps, ulcers and fistula (Fig. 14.14).

Cholangiography: It can be performed in many ways.

Oral cholecystography – Give oral contrast 12-24 hours prior to the study.

Failure to visualise the gallbladder – Acute cholecystitis, peritonitis, pancreatitis and gallstone

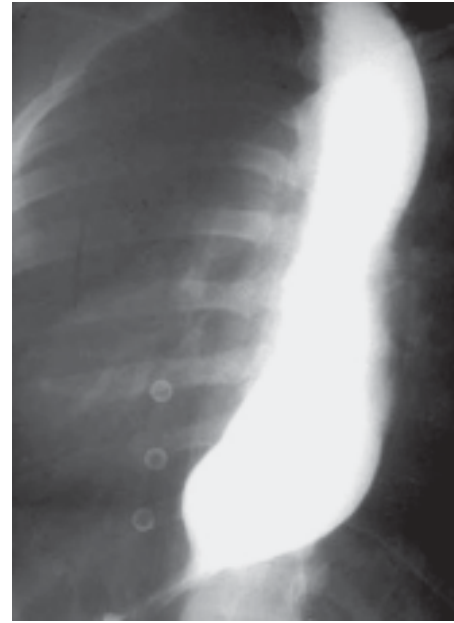

Fig. 14.14: Achalasia cardia

disease. This test is not useful when serum bilirubin is elevated.

Intravenous Cholecystography: It is useful in suspected choledocholithiasis and is seldom indicated.

Percutaneous transhepatic cholangiography (PTC): This investigation is useful to demonstrate dilated ducts in obstructive jaundice. Bleeding tendency, cholangitis, ascites, and allergy are contraindications for this test.

Endoscopic retrograde cholangiopancreatography (ERCP): A catheter is passed with the help of endoscope through the ampulla into the common bile duct (CBD) and X-rays are taken after injecting the contrast medium. It demonstrates the lesion in the biliary tree and the pancreatic ducts. Antibiotic prophylaxis with ciprofloxacin 750 mg PO two hours prior to the procedure is advisable.

Therapeutic Manoeuvres

- Sphincterotomy with CBD stone removal
- Dilatation of benign biliary strictures
- Palliative stents for bile duct obstruction in malignancy.



Complications

- Ascending cholangitis
- Pancreatitis
- Perforation
- Haemorrhage.



Fig. 14.15: Intravenous pyelogram

Intravenous Urography Pyelography (IVU or IVP)

A good preparation is essential for obtaining detailed clinical information after IVP (Fig. 14.15).

Nephrogram

(The image of kidneys as a result of contrast diffusing through them in early stage of contrast excretion)

- Absent – Nonfunctioning kidney (infarction, severe GN)
- Delayed – Renal artery stenosis
- Intense – In obstruction and glomerulonephritis
- Prolonged – In obstruction, chronic GN, renal vein thrombosis, and ATN
- *Nonvisualised Kidney:*
- Renal agenesis
- Nephrectomy–surgical removal along with 12th rib
- Non-functioning kidney
- Obscured by bowel gas or perinephric abscess.

Small Kidney (< 12 cm)/Contracted Kidneys (< 8 cm)

- Chronic pyelonephritis
- Renal artery stenosis
- Bilateral contracted kidneys (ESRD)

Large Kidney (> 14 cm)

- Diabetes mellitus
- Renal tumour

- Renal vein thrombosis
- Amyloidosis
- Polycystic kidneys
- Compensatory following contralateral nephrectomy
- Hydronephrosis
- Myeloma
- Lymphoma
- Bilateral obstruction.

Low-lying Kidney

- Hepatomegaly
- Transplant
- Congenital.

Classical Patterns

- Obstruction – Dense prolonged nephrogram, clubbed calyces, Mega ureters
- Chronic pyelonephritis – Scarred kidney with thin cortex and clubbed calyces
- Papillary necrosis – Linear breaks at papillary bases.

Retrograde Pyelogram

After catheterising, contrast is injected into the ureters. It is useful to detect non-functioning kidney and to locate the site of obstruction.

Micturating Cystourethrogram

The bladder is catheterised and filled with contrast. It demonstrates ureteric reflux during micturition, posterior urethral valves and urethral strictures.

Angiography

- For imaging aorta, major arteries and branches
- To demonstrate atheromatous stenosis, thrombosis, embolism
- To detect aneurysms, AV fistulas, angiomatous malformations
- To delineate tumours
- Interventions – balloon dilatation (angioplasty), embolisation.

Cardiac angiography: To demonstrate cardiac pathology and valvular lesions.

Coronary angiography: For deciding angioplasty and CABG.

Pulmonary angiography: For detecting emboli, vascular abnormalities, assessment of right heart pressure and intervention in massive pulmonary emboli.



Cerebral angiography (carotid/four-vessel): To quantify atheromatous stenosis and to detect aneurysms, AV malformations; for interventional procedures.

Renal angiography: For investigation of renal hypertension and for embolisation of vascular tumours.

Selective visceral angiography: To locate the site of bleeding, selectively infusing drugs or embolic material into the bleeding vessel and to assess the tumour vascularity

Angiography is also used in peripheral vascular disease.

Radioisotope Scanning

Any organ of the body can be imaged by using specific organ selective isotopes.

'Cold areas' – Tumour tissue fails to take up isotope.

'Hot spots' – Tumour tissue may take up more of the isotope.

Cardiac Scanning

^{99m}Tc (Technetium) – It is useful to demonstrate size and function of chambers (cardiac output, ejection fraction), wall motion abnormalities, and shunts.

MUGA scan (Multigated acquisition) – Data collection is synchronised to the ECG to create a dynamic picture of cardiac function. This test can be done at rest and during exercise. It is not suitable when the patient has fast, irregular rhythms. The isotope concentration is more in recently damaged myocardium (24-72 hours) with ^{99m}Tc pyrophosphate scanning.

Thallium-201 scanning – It is taken up by the normal myocardium. Acutely infarcted area (<12 hours) appears 'Hot' and on exercise, ischaemic/infarcted area appears 'Cold', but the ischaemic area returns to normal after rest.

Brain Scanning with ^{99m}Tc

This test was previously used to exclude brain metastases. The test is not reliable and has been replaced with CT and MRI scans.

Ventilation/Perfusion Scan (V/Q Scan)

Perfusion lung scan (Q scan) is done with ^{99m}Tc -labelled albumin macroaggregates or microspheres (Fig. 14.16).

Hypoperfusion due to pulmonary embolus is shown as cold areas. Hypoperfusion due to other causes such as pneumonia, TB, cysts and collapse cannot be differentiated.

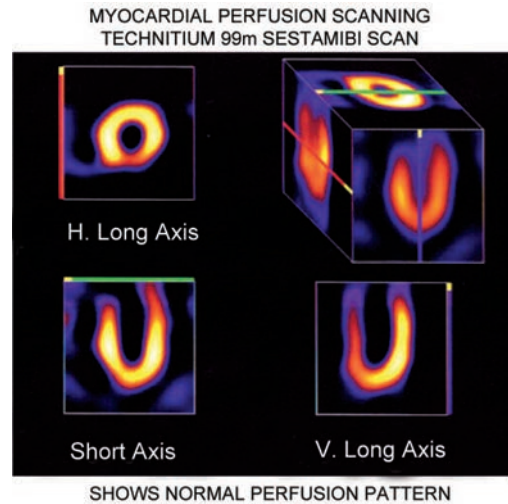

Fig. 14.16: Shows normal perfusion pattern

Ventilation scan (V scan) is done following inhalation of radioactive xenon (^{133}Xe) or Krypton (^{81m}Kr).

In pulmonary embolism, Q scan shows filling defect whereas the V scan will be normal.

^{99m}Tc Bone Scan

Technetium labelled phosphate complexes are used to detect bone metastases especially from thyroid, kidney, breast, lung and prostate cancer. Benign lesions such as osteoarthritis, rheumatoid arthritis, fibrous dysplasia and fractures also take up isotope and may interfere with diagnosis of metastatic bone disorders.

Renal Scans

^{99m}Tc -DTPA is used for the assessment of renal function, renal blood flow, estimation of GFR and evaluation of collecting system.

^{99m}Tc -DMSA is used for imaging renal cortex. Reduced and uneven uptake of isotope is seen in chronic pyelonephritis, obstructive uropathy and TB. Tumours and cysts show up as filling defects.

^{131}I -Hippuran is also useful for the evaluation of renal function since it is excreted entirely in one passage.

Adrenal Scan

Imaging is done with ^{79}Se -cholesterol and it reveals tumours producing Cushing's and Conn's syndrome. It fails to reveal adrenal tumour causing pheochromocytoma.

Metiodobenzylguanidine (MIBG) scanning reveals pheochromocytoma as well as metastases from adrenal tumours.

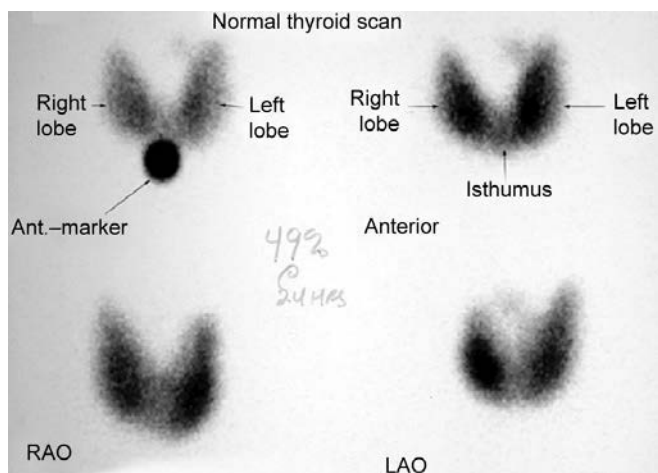

Fig. 14.17: Isotope scanning of thyroid

Hepatobiliary Scan

^{99m}Tc colloid is used for imaging liver. Mass lesions above 2 cm diameter such as tumour, cysts, abscesses, and haematomas appear as cold spots.

^{99m}Tc -HIDA (Hepato imminodiacetic acid) is used to scan biliary tree. Failure to visualise gallbladder may be either due to acute cholecystitis or due to cystic duct obstruction. Failure to excrete into the duodenum can be due to biliary atresia.

Thyroid Scan (Fig. 14.17)

It can be done either with ^{99}Tc -pertechnetate or with ^{125}I to evaluate nodules (25% Solitary cold nodules are malignant). It is very useful to localise ectopic thyroid tissue.

Thyroid function tests, and ultrasound imaging along with isotope scan can aid in the diagnosis of hyperfunctioning adenoma, multinodular goitre, toxic nodules and Graves' disease.

White Cell Scan

Indium or technetium labelled peripheral blood leukocytes provide the very useful non-invasive way of localising hidden pus and also to monitor inflammatory activity in inflammatory bowel disorders (Crohn's and ulcerative colitis).

Gallium-67 Scan

It is very much useful to localise abscesses of 5-10 days old, and chronic inflammatory lesions. It is also useful in the assessment of spread of neoplasms and lymphoma particularly in the mediastinum.

Amyloidosis can be diagnosed by using radiolabelled serum amyloid P protein.

Positron Emission Tomography (PET)

It is the most useful investigation to detect whether the cell is alive, functioning and the status of blood flow. Molecules labelled with positron emitting radionuclides are injected and 3D images are obtained to assess the blood supply (labelled ammonia) and glucose metabolism (fluorodeoxyglucose-FDG).

Recurrent Tumours

After radiotherapy to differentiate between cell death and tumour recurrence PET scan is very valuable. This helps in planning further management such as the need for stereotactic radiotherapy.

Cardiology

It is useful to differentiate between hibernating and dead myocardium. Presence of normal glucose metabolism with low blood flow denotes hibernating myocardium.

PCI like angioplasty could improve the blood supply and function.

Neurology

It is very much useful to diagnose dementia much earlier even before symptoms appear.

Alzheimer's dementia – Symmetrical hypometabolism in parietal and temporal lobes.

Pick's dementia – Hypometabolism affecting the frontal lobes.

PET scan is also useful to identify epileptogenic foci when there is no anatomic lesion as evidenced by MRI/CT.

PET scan is very costly and it is used mainly for research.

Ultrasound

Diagnostic ultrasound is a recently developed non-invasive technique which can furnish valuable clinical information and is often the first line of investigation for abdomen, heart, arterial and venous systems, thyroid, orbit and eyes, ovaries and testicular lesions.

It is safe, painless, inexpensive, convenient, repeatable and it entails no ionising radiation. .

Abdominal Scan (Fig. 14.18)

1. Liver size and texture – enlarged fatty liver/shrunken cirrhotic liver/cysts/tumour
2. Biliary system – dilated ducts in obstruction – tumour/stone
3. Spleen – size, evidence of portal hypertension, splenic vein thrombosis

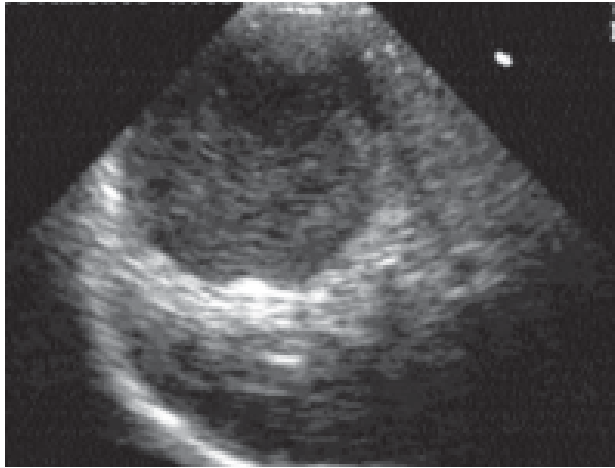

Liver abscess



Liver secondaries

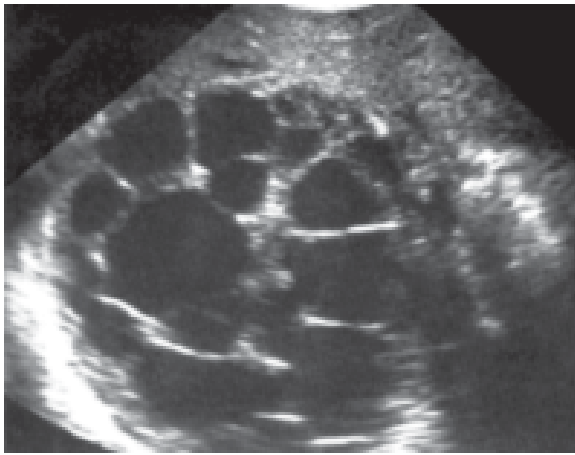

Hydatid cyst—liver



Gall bladder calculi

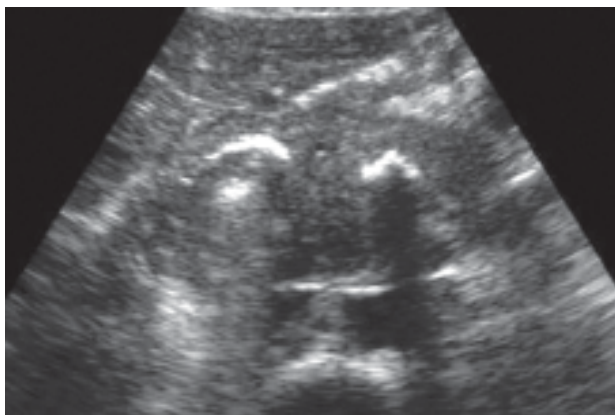

Chronic calcific pancreatitis

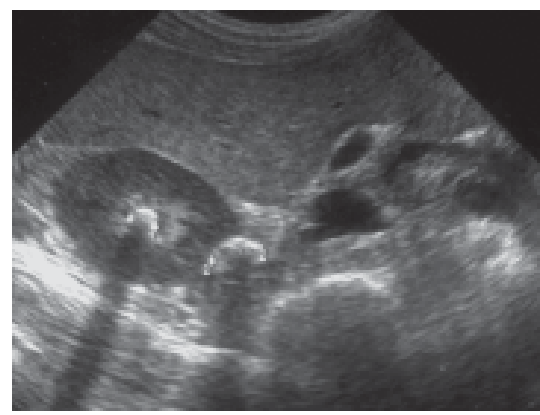

Renal calculi

Fig. 14.18: Ultrasound—abdomen



Imaging Intensity—Ultrasound Abdomen

Organ	Hyperechoic	Hypoechoic	Anechoic
Liver	Stones, metastases, granulomas, cirrhosis, hemangiomas	Metastases, abscesses	Cysts, abscesses
Spleen	Hemangiomas, granulomas	Haematoma, Lymphoma, metastases	Cysts, abscesses
Gallbladder	Calculi, polyps	Carcinoma, empyema	Cholecystitis, abscesses
Kidneys	Calculi, lipoma, angioma	Abscesses, metastases, CA	Cysts, Dilated pelvi-calyceal system
Pancreas	Chronic pancreatitis, calculi	Acute pancreatitis, carcinoma	Abscesses, cysts, pseudocysts

- Gallbladder – thickening of wall, polyp, gallstones
- Pancreas – Pseudocysts, abscesses, tumour, calculi
- Kidneys – enlarged or contracted, calculi, hydronephrosis, polycystic disease, mass lesions, adrenal mass lesions
- Aneurysms of aorta and major vessels
- Doppler studies of portal and splanchnic veins – to assess direction of flow and to rule out thrombosis
- To monitor normal and abnormal pregnancy
- To monitor fetal growth and development
- Localisation of placenta
- To identify ectopic pregnancy
- Ovarian mass lesions including PCOD
- Uterine mass lesions
- Testicular size, mass lesions, hydrocele.

Echocardiography

This non-invasive technique offers a wealth of anatomic and physiologic information of the heart. It is safe, painless, repeatable, inexpensive and it does not utilise ionising radiation. All the modern equipments provide the following facilities:

- M-mode
- B-mode or two dimensional echocardiography
- Pulsed Doppler
- Continuous wave Doppler
- Colour-flow imaging.

M-mode echocardiography: It gives an ice-pick view of the heart and it has many limitations. It allows measurements of chamber size, assessment of valve and wall motion. Cardiac structures closer to the transducer are displayed at the top of the record and the distant structures are displayed below (on trans-thoracic M mode echocardiogram –the anteriorly placed right sided structures are displayed on the top and the posteriorly placed left sided structures displayed on the bottom and the order is reversed in the trans-oesophageal echocardiogram).

B-mode or two dimensional echocardiography:

- Useful in the diagnosis of congenital heart disease such as
 - Septal defect
 - Congenital valvular disease
 - Relationship of great vessels to the cardiac chambers
 - Foetal imaging for the antenatal diagnosis of congenital heart disease
 - Malposition of the heart
- To assess the cardiac chamber hypertrophy, dilatation, systolic and diastolic dysfunction, type of cardiomyopathy
- To assess the type of valvular lesion – congenital, rheumatic, degenerative
- To diagnose infective endocarditis – vegetation > 2 mm size
- To diagnose pericardial thickening, effusion and impending cardiac tamponade
- Useful for the evaluation and diagnosis of coronary artery disease (including stress echo and pharmacological stress test)
- Doppler echocardiography is used to assess the direction and velocity of blood flow in the heart and great vessels (to detect shunts, regurgitant lesions and quantify valvular stenosis)
- Colour flow data when superimposed on B-mode echocardiography provides more useful qualitative data. The colour coded mapping reveals red colour indicating flow towards and the blue away from the transducer.

Thyroid Scan

- Useful to measure the size of thyroid enlargement and also to differentiate cyst, nodule/tumour.
- Not useful to differentiate benign and malignant nodule.

Orbit and Eye

- Aids in the localisation of foreign bodies



- Assessment of retinal and choroidal detachment
- Assessment of retro-orbital mass lesions.

Large Veins and Arteries

- Assessment of blood flow in the limbs
- To assess the extent of thrombosis.

Special Techniques

- Trans-oesophageal echocardiogram to assess mitral valve lesions and vegetations in infective endocarditis
- Trans-vaginal to study uterine and ovarian lesion
- Trans-rectal to assess the lesions of prostate and rectum
- Intravascular ultrasound – to study the extent of plaque, and it has a clinical role in coronary angioplasty and stenting
- Endoscopic ultrasound – Assessment of depth of mucosal penetration in cancer and thus helpful in staging (Ca oesophagus, stomach, colon and rectum).

Computed Tomography (CT Scan)

The X-ray beam moves around the patient in a circular path and the slices can be cut at various levels. The detailed images are constructed from X-ray absorption data with the help of the computer. CT scan is very useful in stroke patients to differentiate infarction from haemorrhage since the treatment modality is different. In major trauma with head injury CT scan is the most important investigation of choice.

CT scan is performed with or without contrast. Contrast CT is useful in abdomen, pelvis and brain. It helps in GI tract to delineate the bowel and in brain to assess the vascularity of mass lesions and in performing carotid or 4 vessel angiogram.

Density measurements are essential to differentiate cyst, tumour, and haematomas. It is expressed in "Hounsfield Units". (Water is 0, bone is +1000, air is -1000 Units, fat -50 to -150 and it varies for other tissues depending on the density)

Skeletal system disorders are better imaged by CT-scan.

CT Brain

CT scan is useful for the diagnosis and assessment of various lesions:

- Fracture involving skull vault or base
- Hydrocephalus – dilated ventricles with effaced sulci and thinned out cortex
- Infarction (area of low attenuation with or without mass effect) and haemorrhage (high density lesion)

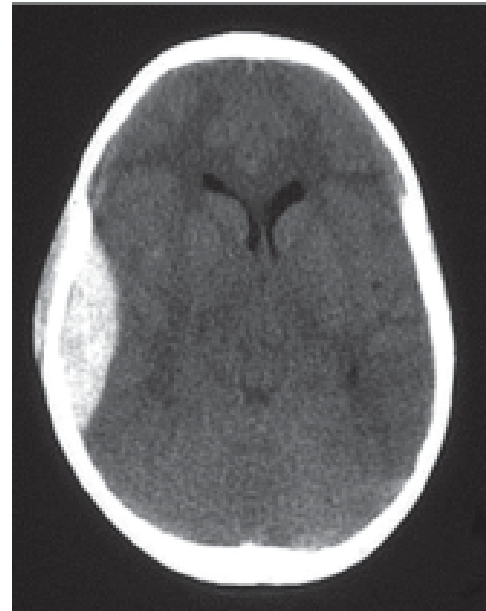

Fig. 14.19: Extradural haematoma

- Cerebral oedema due to stroke or different types of metabolic coma
- Mass lesions with or without midline shift
- High density extradural or sub-dural haematoma in acute phase (Fig. 14.19)
- Low density chronic subdural haematoma
- Various types of cerebellar lesions
- Multiple sclerosis and metastatic lesions
- Cerebral atrophy – Prominence of the sulci and atrophy of the gyri.

CT Chest (Fig. 14.20)

- High resolution CT is investigation of choice to diagnose bronchiectasis
- Detecting and staging primary cancer of the lungs, pleura, and mediastinum
- To diagnose metastases of the lungs/pleura
- To detect infiltrative lung disease
- For the diagnosis of pulmonary emboli
- Evaluation of interstitial lung disease.

CT Angiography

Angiography is a minimally invasive medical test that helps physicians diagnose and treat medical conditions. Angiography uses one of three imaging technologies and, in some cases, a contrast material to produce pictures of major blood vessels throughout the body.

Angiography is performed using:

- X-rays with catheters

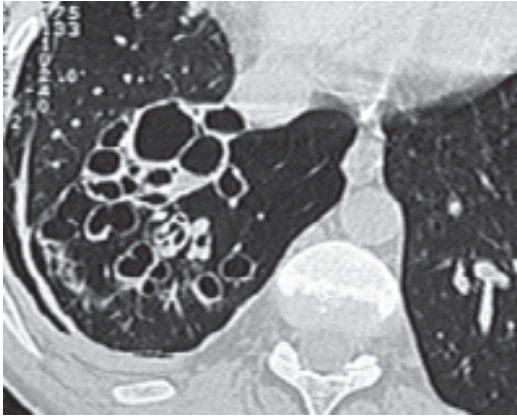

Bronchiectasis

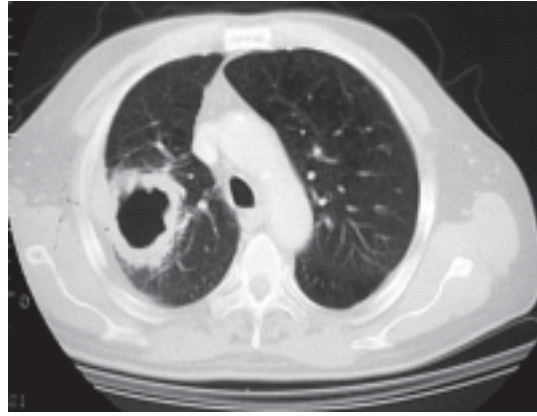

Cavitating bronchogenic carcinoma

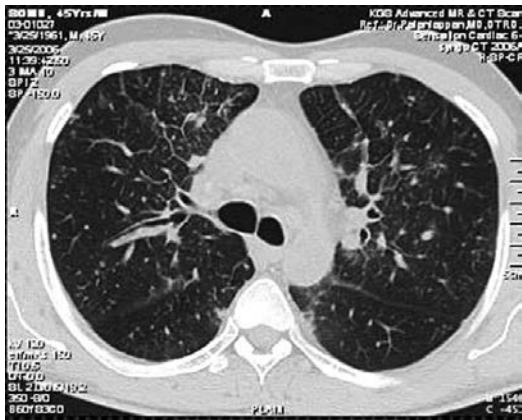

Lymphangitis carcinomatosa



Pulmonary embolism



Right sided pneumothorax
Note: The ruptured BLEB in apex of lung
is indicated by arrows

Fig. 14.20: CT Chest (contd...)

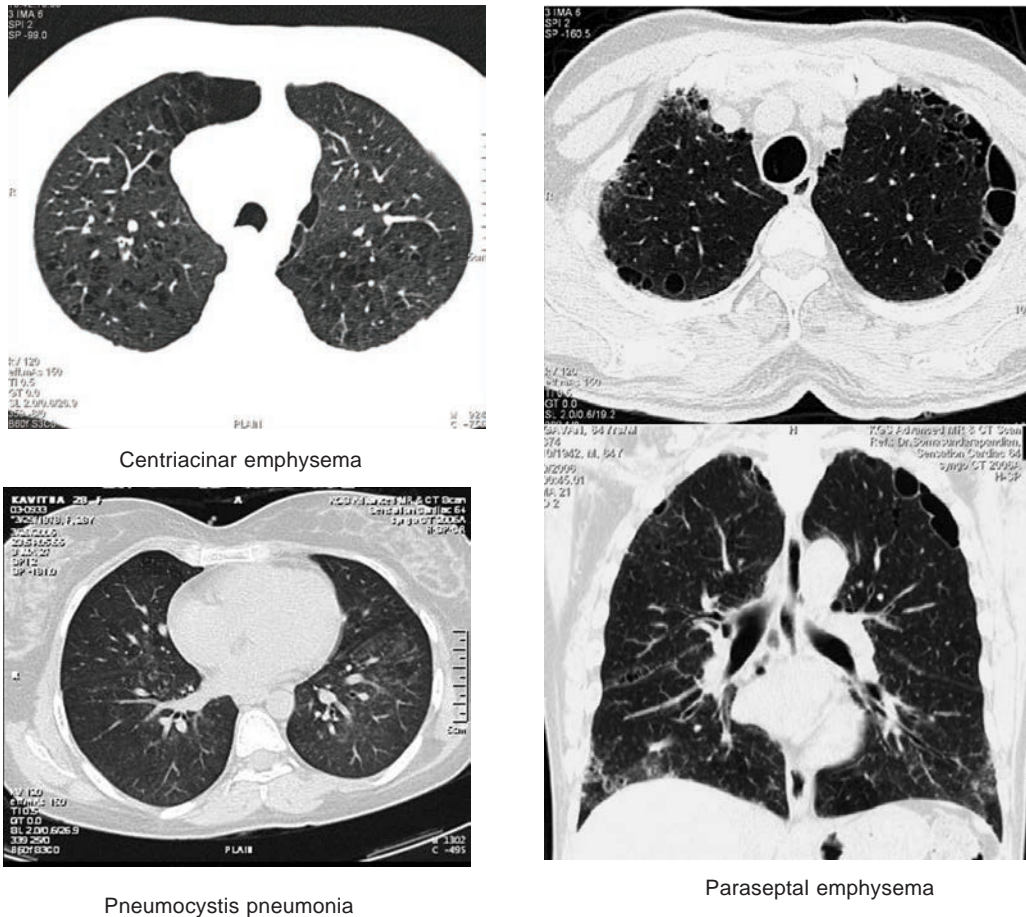

Fig. 14.20: CT Chest

- Computed tomography (CT)
 - Magnetic resonance imaging (MRI)
- CT imaging uses special X-ray equipment to produce multiple images and a computer to join them together in multidimensional views. In CT angiography (CTA), computed tomography using a contrast material produces detailed images of both blood vessels and tissues.
- Areas of the body, including the:
- brain
 - kidneys
 - pelvis
 - legs
 - lungs
 - heart
 - neck
 - abdomen
- Identify disease and aneurysms in the aorta, both in the chest and abdomen, or in other major blood vessels.
 - Detect atherosclerotic disease in the carotid artery of the neck, which may limit blood flow to the brain and cause a stroke.
 - Identify a small aneurysm or arteriovenous malformation inside the brain.
 - Detect atherosclerotic disease that has narrowed the arteries to the legs and help prepare for endovascular intervention or surgery.
 - Indicate disease in the arteries to the kidneys or visualise blood flow to help prepare for a kidney transplant.
 - Guide interventional radiologists and surgeons making repairs to diseased blood vessels, such as implanting stent or evaluating a stent after implantation.
 - Detect injury to one of more arteries in the neck, chest, abdomen, pelvis or extremities in trauma patients.
 - Evaluate arteries feeding a tumour prior to surgery or other procedures such as chemoembolisation or selective internal radiation therapy.

- Identify dissection or splitting in the aorta in the chest or abdomen or its major branches.
- Show the extent and severity of atherosclerosis in the coronary arteries and plan for a surgical operation, such as a coronary bypass.
- Plan for a surgical operation, such as coronary bypass.
- Sample blood from specific veins in the body to detect any endocrine disease.
- Examine pulmonary arteries in the lungs to detect pulmonary embolism.

Benefits

- Angiography may eliminate the need for surgery. If surgery remains necessary, it can be performed more accurately.
- CT angiography is able to detect narrowing of blood vessels in time for corrective therapy to be done.
- CT angiography gives more precise anatomical detail of blood vessels than magnetic resonance imaging (MRI).
- Many patients can undergo CT angiography instead of a conventional catheter angiogram.

Compared to catheter angiography, which involves placing a catheter (plastic tube) and injecting contrast material into a large artery or vein, CT angiography is a much less invasive and more patient-friendly procedure.

- This procedure is a useful way of screening for arterial disease because it is safer and much less time-consuming than catheter angiography and is a cost-effective procedure. There is also less discomfort

because contrast material is injected into an arm vein rather than into a large artery in the groin.

- No radiation remains in a patient's body after a CT examination.
- X-rays used in CT scans usually have no side effects.

Risks

- There is always a slight chance of cancer from excessive exposure to radiation. However, the benefit of an accurate diagnosis far outweighs the risk.
- If you have a history of allergy to X-ray contrast material, your radiologist may advise that you take special medication for 24 hours before CT angiography to lessen the risk of allergic reaction. Another option is to undergo a different exam that does not call for contrast material injection.
- If a large amount of X-ray contrast material leaks out from the vessel being injected and spreads under the skin where the IV is placed, skin damage or damage to blood vessels and nerves, though unlikely, can result. If you feel any pain in this area during contrast material injection, you should immediately inform the technologist.
- Women should always inform their physician and X-ray or CT technologist if there is any possibility that they are pregnant.
- Nursing mothers should wait for 24 hours after intravenous contrast material injection before resuming breast feeding.
- The risk of serious allergic reaction to contrast materials that contain iodine is extremely rare, and radiology departments are well-equipped to deal with them.

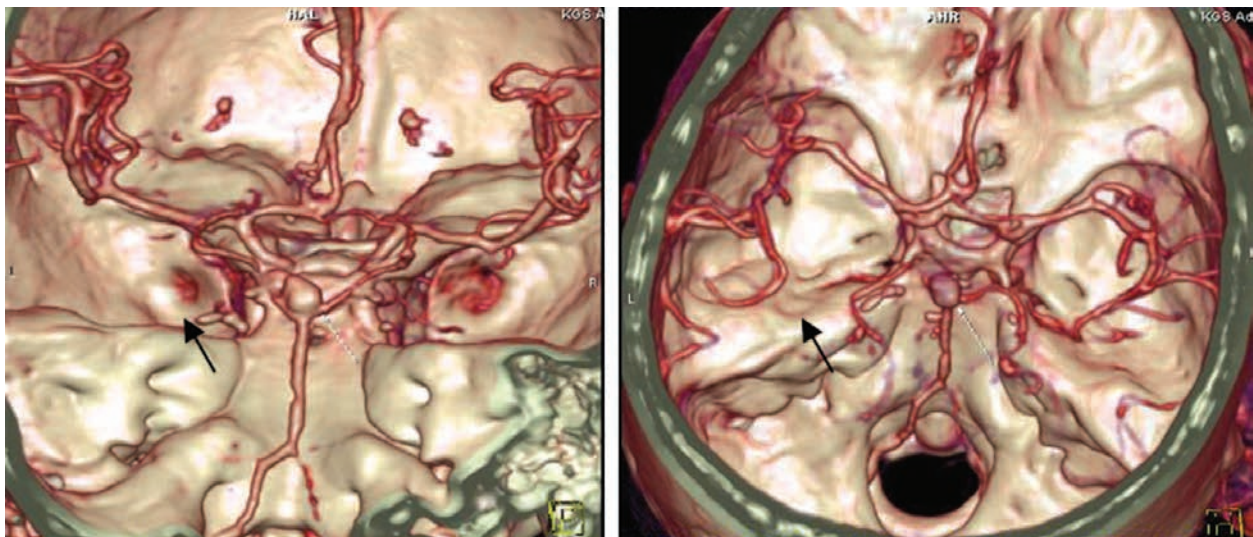

Fig. 14.21: CT angiography skull 3D rendering, arrow shows the basilar artery aneurysm

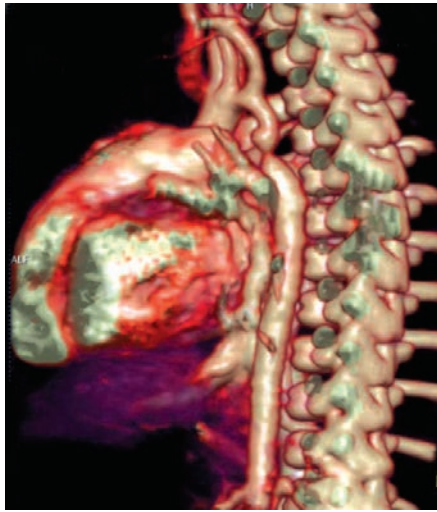

Fig. 14.22: CT angiography of thorax and abdomen MPR and 3D reconstruction and arrow shows the coarctation of aorta at the origin of thoracic aorta



Fig. 14.23: CT renal angiography (arteriography), MPR and 3D reconstruction shows 2 right renal arteries from aorta and left renal artery occlusion at the root

CT Coronary Angiography (Figs 14.21 to 14.24)

- Multi-slice computed tomography scanners are used
- Coronary angiography is performed with 64 slice technology
- 80 ml iodixanol is injected into an ante-cubital vein at a flow rate of 5 ml/s followed by a 50 ml saline chasing bolus

- The overall scan time is shorter than 15 seconds and the total period of study is less than 15 minutes
- The main contraindications are allergy to iodine contrast and severe renal insufficiency
- This technology is 95% specific and sensitive with 85% positive predictive value and negative predictive value is 99%

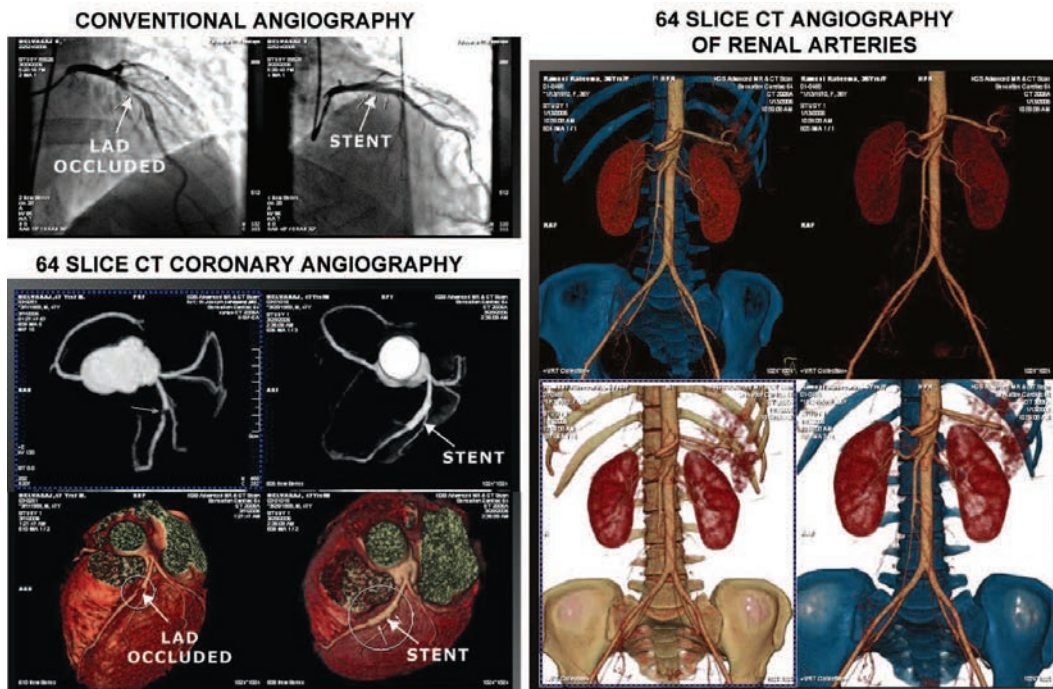
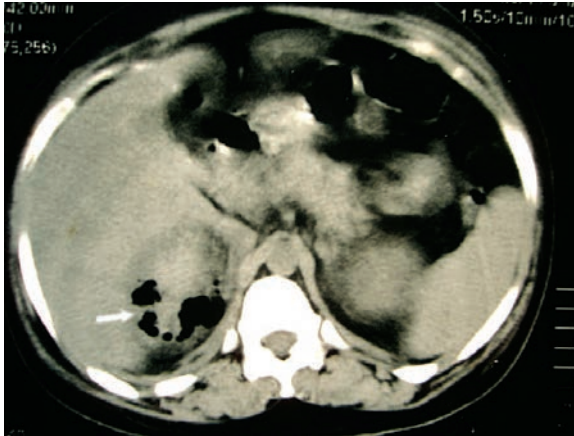
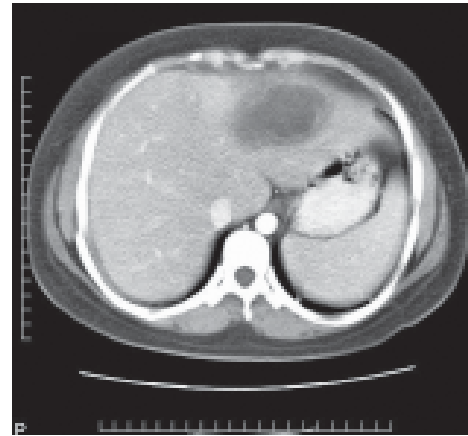

Fig. 14.24: 64 slice CT angiography



Emphysematous pyelonephritis



Amoebic liver abscess



Chronic calcific pancreatitis
Note the curvilinear calcifications in CT

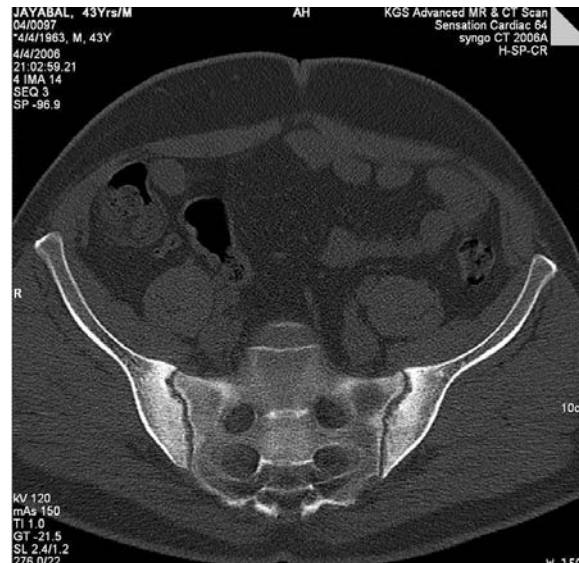

Sacroiliitis-seronegative arthritis

Fig. 14.25: CT abdomen and pelvis

- Extensive arterial wall calcification interferes with proper vessel assessment.

CT – Abdomen (Fig. 14.25)

- For accurate evaluation of pathology in obese individuals
- To detect smaller lesions missed by ultrasound
- Pancreas and its disorders better demonstrated
- Helpful in delineating renal and adrenal masses
- To assess para-aortic and retro-peritoneal lymphadenopathy
- Spiral CT is useful in imaging solid organs, retroperitoneal structures and small or large bowel obstruction

- For monitoring invasive procedures – biopsies, placement of drainage tubes
- Used in the staging of abdominal and haematological malignancies.

Magnetic Resonance Imaging (MRI)

MR imaging uses the disturbance induced on the resonance of protons in the body tissue in a uniform magnetic field. An image could be constructed in any chosen plane with the help of pulsed radiofrequency energy source. MR images are constructed from the rate of decay or relaxation of proton resonance either in the plane longitudinal or transverse to the magnetic field.

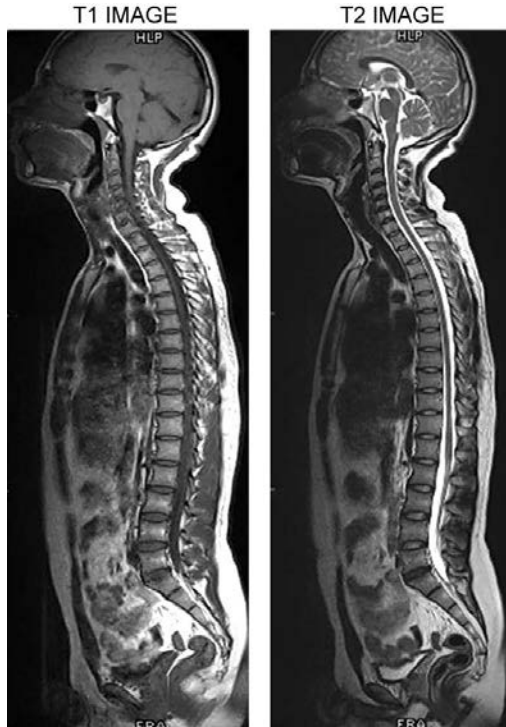

Fig. 14.26: Magnetic resonance imaging



Fig. 14.28: Multiple spine secondaries



Fig. 14.27: Pott's spine

- T₁ images – Reflects the time taken for the protons to return to the axis of the original field.
- T₂ images – Time for the protons to dephase.
- T₁ weighted images provide good anatomical planes and also useful to differentiate cystic or solid structures

- T₂ weighted images are useful to study the pathology. Moving blood is black in T₁ images and bright in GRE sequences and it is possible to reconstruct blood vessel morphology. This technique is very useful in non-invasive angiography of different organs. The sensitivity of MR images are enhanced by spin-echo sequences, and contrast enhancement with gadolinium (a rare earth element) (Figs 14.26 to 14.32).

Advantages of MRI

- No radiation
- To obtain images in any plane–sagittal/coronal/axial
- Non-invasive angiography (Cerebral, Coronary, Renal and Peripheral)

Differentiating Features between T₁ and T₂ weighted images

Structures	T ₁ weighted	T ₂ weighted
Water	Black	White (bright)
Fat	White (bright)	White
Air	Black	Black
Muscles	Grey	Dark grey
Tendons/ ligaments	Black	Black
Bone	Black	Black
Tumours	Grey	White

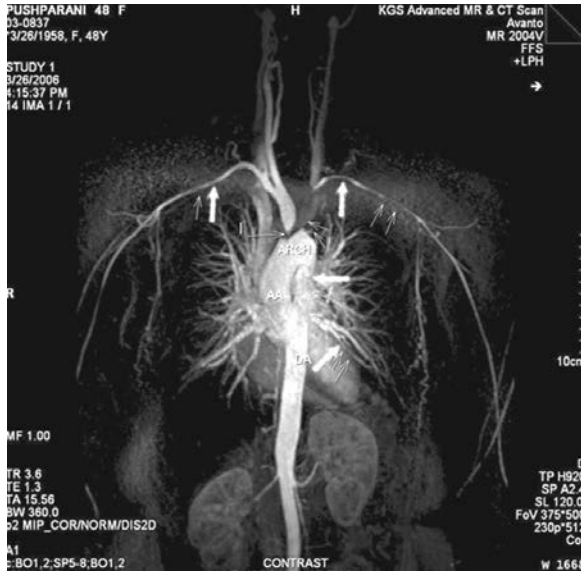

Fig. 14.29: Takayasu's arteritis-MR angiography (bilateral subclavian and PA involved)

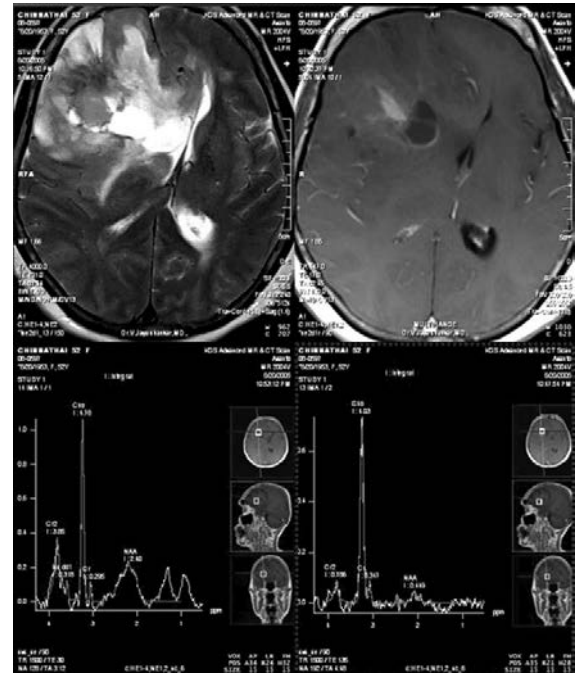

Fig. 14.31: Glioblastoma multiforme—MR spectroscopy showing choline peaking along with NAA is suggestive (NAA-N-Acetyl aspartate)



Fig. 14.30: Tuberculoma-cerebellum



Fig. 14.32: MR angiography—iliofemoral disease

- Best images of brain/spinal cord, aorta/vena cava
- Visualisation of posterior fossa/cranio-cervical junction
- Best images for soft tissue lesions
- Better imaging of pancreas, adrenals, biliary tree, and lesions of pelvis

- MR urography – bowel preparation not required and can be performed even if renal function is impaired (outlines the dilated PCS even in the presence of poor renal function)
- MR urography – extrinsic obstructions of urinary tract better visualised than in IVU.



Diffusion-Weighted MRI (Fig. 14.33)

Diffusion-weighted imaging is an MR imaging technique in which contrast within the image is based on microscopic motion of water. Lesions with diffusion restriction appear bright on DW images and those structures with increased diffusion like CSF will appear dark on DW images. It detects evaluation of ischaemic stroke in the early stage.

Disadvantages of MRI

- Relatively high cost
- Unsuitable for patients with metal foreign bodies (pacemakers, cochlear implants, vascular clips)
- Difficult to image calcium
- Difficult to image critically ill patients with monitoring equipments
- Claustrophobia
- Long imaging time results in increased motion artifacts

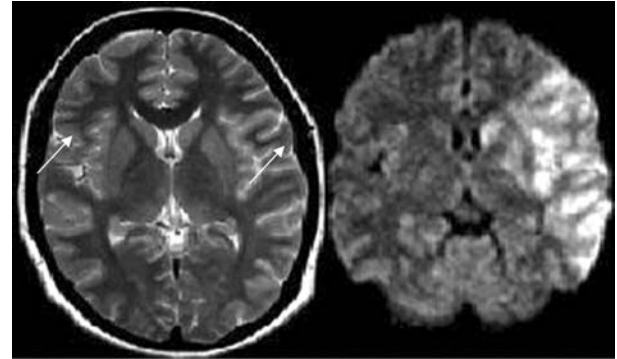

Fig. 14.33: Evaluation of acute stroke on DWI. Patient with acute onset of right-sided weakness. T2-weighted MR image shows absent flow voids in left insular region without any appreciable signal changes in the cortex. DW image clearly demonstrate the acute infarction in left MCA territory

- MR urography – normal ureters not well visualised.



Chapter 15

Procedures

PROCEDURES

DIAGNOSTIC/THERAPEUTIC
ELECTIVE/EMERGENCY

DISCUSSION WITH PATIENT/RELATIVES

Nature of the procedure
Advantage and its
Disadvantages
Complications

INFORMED CONSENT (Patient/Relatives)

ADEQUATE KNOWLEDGE AND EXPERTISE ABOUT THE PROCEDURE

Indications
Contraindications
Precautions-asepsis and
Universal precautions
Limitations
Complications and its
management

PREPARATION OF THE PATIENT

PREPARATION OF THE ENVIRONMENT AND EQUIPMENT

PREPROCEDURE EXAMINATION

PROPER COLLECTION, HANDLING AND TRANSPORTATION OF SPECIMENS

AFTERCARE OF THE PATIENT

DISPOSAL OF BIOMEDICAL WASTE

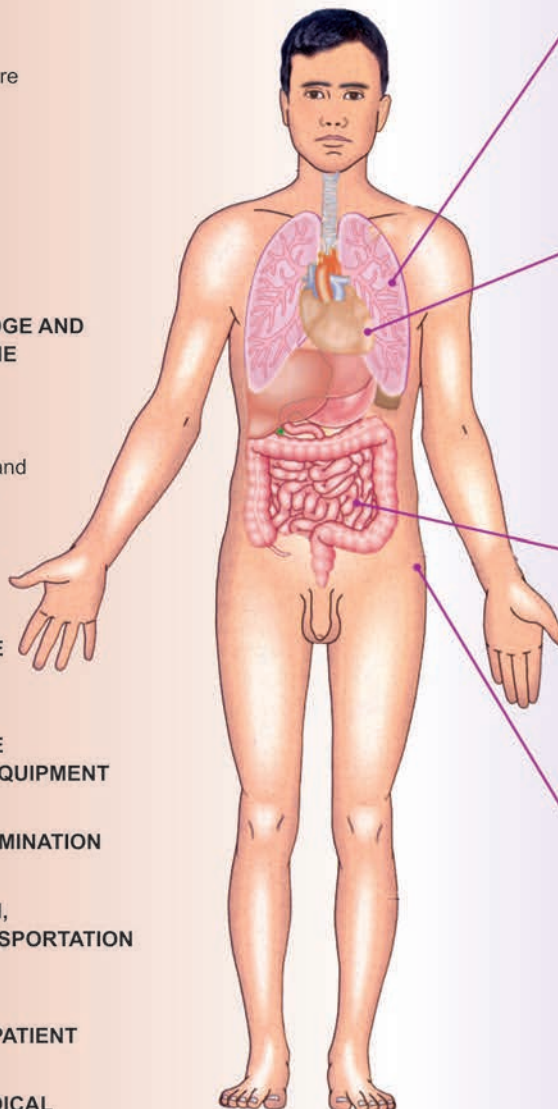

PLEURAL ASPIRATION
BIOPSY
INTERCOSTAL TUBE
DRAINAGE
TRACHEOSTOMY
ENDOTRACHEAL
INTUBATION



PERICARDIOCENTESIS
CENTRAL VEIN
CANNULATION
ARTERIAL PUNCTURE

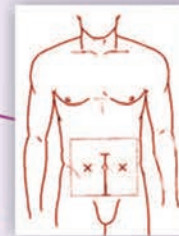

PARACENTESIS
LIVER BIOPSY
RENAL BIOPSY
BLADDER
CATHETERISATION



BONE MARROW
ASPIRATION/
BIOPSY



LUMBAR PUNCTURE

Pleural Aspiration and Biopsy

Indications for Pleural Aspiration

1. Diagnostic
2. Therapeutic
3. Instillation of drugs (cytotoxic drugs, steroids) or chemicals (talc).

Indications for Therapeutic Aspiration

1. Moderate to massive effusion
2. Pyothorax (thin pus).

If pleural biopsy is planned, it should be performed with the first aspiration.

Site of Aspiration

1. 6th intercostal space in the mid axillary line
2. 7th intercostal space in the posterior axillary line
3. 8th intercostal space in the scapular line.

For loculated effusion, aspiration is done at the site of maximal area of dullness.

Pleural Aspiration Needle

The needle is available in varying sizes and has no stylet. The needle is always attached to a 3-way adapter while performing pleural aspiration in order to prevent air from entering the pleural cavity.

Procedure

The patient should be comfortable and relaxed and the procedure should be explained to him.

The patient is positioned leaning slightly forward with his arms folded before him and kept over a cardiac rest with a pillow over it.

After testing for sensitivity to local anaesthetic (2% xylocaine) by intradermal injection, the site of aspiration is infiltrated from the skin to parietal pleura.

Under strict aseptic precautions, the needle is inserted into the pleural cavity. The needle should be inserted just above the upper border of the lower rib to avoid injury to intercostal vessels and nerves, which run along the lower border of each rib.

The pleural needle is attached to a 3 way adapter which is in turn attached to a syringe. The pleural fluid is aspirated by applying suction to the syringe and then extruded from the syringe into a kidney tray by adjusting the 3 way adapter.

It is advisable never to aspirate more than 750–1000 cc in the first sitting for fear of reexpansion pulmonary oedema. If the patient coughs or becomes dyspnoeic, the procedure must be abandoned.

For diagnostic aspiration, about 50 cc of fluid is sufficient.

Repeat aspiration must be done every 3 to 4 days, after taking check X-rays, after each procedure.

At times even in the presence of a massive effusion, the pleural effusion might disappear completely after a single aspiration and full expansion of the lung may occur. This is due to the constant dynamic state of pleural fluid production and reabsorption. Aim should be to allow the passively collapsed lung to expand in the earliest possible time.

In case of transudative effusion, diuretic therapy alone may sometimes be sufficient to treat the pleural effusion or interlobar effusion (phantom tumour/vanishing tumour).



Complications

1. Pleural shock
2. Reexpansion pulmonary oedema
3. Pneumothorax, hydropneumothorax
4. Haemothorax
5. Pyothorax
6. Injury to intercostal vessels and nerves
7. Air embolism
8. Intercostal artery aneurysm (late complication).

Dry Tap

It is the failure to obtain pleural fluid on attempted aspiration.



Causes

1. Thick pus (empyema)
2. Lung parenchyma or pleural disorder simulating pleural effusion (consolidation, carcinoma lung, pleural tumour, pleural thickening).
3. Haemothorax
4. Loculated effusion
5. Interlobar or infrapulmonary effusion.

In the above mentioned causes, an ultrasound or CT guided aspiration may be needed.

Pleural Biopsy

An Abrams punch biopsy needle is used (Fig. 15.1).

The position and preparation of the patient is the same as in the pleural aspiration.

A 'nick' is made with the scalpel at the site of aspiration and a closed Abrams needle is introduced into the pleural cavity. The stylet is removed and the



Fig. 15.1: Abram's needle

pleural fluid let out in the usual manner. The needle is aligned such that the notch entraps the parietal pleura and then punched with punch needle. The direction of the notch can be identified by the direction of the mark on the base of the needle. The needle is then withdrawn with a slight rotary action. The biopsy specimen of the parietal pleura is recovered from the notch.

Lumbar Puncture

Indications

1. Diagnostic—in suspected meningitis
2. Investigatory procedure—encephalography and myelography
3. Therapeutic—introduction of cytotoxic drugs like methotrexate or steroids intrathecally.

Contraindications

1. Papilloedema (raised intracranial tension)
2. Local skin sepsis (bed sore).

Fundus examination is a must before doing lumbar puncture.

Lumbar Puncture Needle

The needle has a stylet. The base of the needle has a notch to accommodate the stylet.

Procedure

The patient is asked to lie in the left lateral decubitus position with the lower limbs drawn up so that the knees

almost touch the chin and the neck is flexed. The patient is placed at the edge of a firm couch. A co-operative patient can maintain the above posture by clasping the hands beneath his knees. In an uncooperative patient, an attender is asked to maintain the posture. A pillow is placed in between the legs to make the back vertical.

In presence of degenerative disorder of the spine (lumbar spondylosis), a sitting posture may be adopted for the procedure.

The procedure is done under strict aseptic precautions and under local anaesthesia (infiltration of the skin and deeper tissues using 5 ml of 2% lignocaine).

A line is drawn using a swab dipped in an antiseptic solution joining the highest points of the iliac crests that passes between L₃ and L₄, which is the intervertebral space of choice for performing lumbar puncture.

The bevelled edge of the lumbar puncture needle should face upwards to avoid injury to ligamentum flavum which runs longitudinally (splitting rather than tearing).

The needle should pierce the skin about 1 cm below the spinous process of the vertebra lying above.

The direction of the needle should be in a cephalic direction towards the umbilicus.

The needle is pushed in with the stylet. There is the resistance felt due to the spinal ligament and dura mater. On piercing the dura, there is a feeling of 'give way'. The stylet is now removed, and the CSF is seen to flow out.

The CSF is collected in 3 sequentially numbered bottles (8 drops in each bottle and not to exceed maximum of 3 cc).

After the procedure the patient is advised to lie flat for about 4 hours with the foot end of the bed raised.



Complications

1. Meningitis (iatrogenic)
2. Post lumbar puncture headache
3. Coning (in the presence of raised intracranial tension)

Bloody Tap

- If the CSF is bloody, the fluid is collected in 3 bottles.
- If fluid is uniformly blood stained in all 3 bottles, it is an internal bleed.
- If fluid is not uniformly blood stained, it is due to a traumatic tap.
- If there is a persisting doubt as to the source of bleed, the fluid sample is centrifuged.
- If the supernatant fluid is xanthochromic, it is due to an internal bleed.

- If the supernatant fluid is clear, it is due to a traumatic tap.

In a blood stained fluid, even though the biochemical analysis may not be very useful, a rough formula can be used to estimate CSF WBC count and protein value by estimating them in the 3rd bottle.

To estimate the number of WBCs in the CSF, the following formula is used.

$$W = \text{CSF WCC} - \left[\frac{\text{blood WCC} \times \text{CSF RBC}}{\text{blood RBC}} \right]$$

Where, W = WBC count in CSF
WCC = white cell count.

If the patient's blood count is normal, the rule of thumb is to subtract from the total CSF WCC (per mL), one white cell for every 1000 RBCs.

To estimate the true protein level subtract 10 mg/L for every 1000 RBCs/mm³ in the CSF obtained from the same bottle.



Causes of High CSF Protein

1. Guillain-Barre syndrome
2. Spinal tumours
3. Acoustic neuroma
4. Meningitis
5. Multiple sclerosis
6. Diabetes mellitus
7. Hypothyroidism.

Queckenstedt's Test

This test is done to detect if there is any block in the CSF pathway by measuring the CSF pressure using a manometer.

Procedure

Lumbar puncture is performed in the usual way. The stylet is removed and the lumbar puncture needle is attached to a manometer. The CSF pressure is read in the manometer.

Normal CSF pressure in the lateral decubitus position is up to 150 mm (or 15 cm) of CSF/H₂O.

In the sitting posture, normal CSF pressure is up to 250 mm (or 25 cm) of CSF/H₂O.

Queckenstedt's test is performed by compressing both jugular veins and noting the rise in CSF pressure in the manometer.

Normal rise of CSF pressure noted is > 40 mm of CSF/H₂O (*negative Queckenstedt's test*).

If there is a block to the CSF flow (spinal tumour), there is no rise in CSF pressure on performing the test.

(*positive Queckenstedt's test*). This is usually accompanied by a yellowish discolouration of the CSF due to high protein content (*Froin's syndrome*).

In partial block, CSF pressure may rise (but not up to 40 mm of CSF) or there may be a jerky rise or fall of pressure on applying/releasing the pressure on the jugular veins.

If pressure is applied on the jugular veins sequentially, it is possible to assess the side of transverse venous sinus thrombosis. When pressure is applied to jugular vein opposite to the side of the transverse venous sinus thrombosis, there is a rise in CSF pressure.

Commonest cause of low CSF pressure is bad needle placement, other causes being cerebellar tonsil herniation or spinal block.

Increased CSF pressure more than 250 mm of CSF is abnormal and no attempt should be made to drain more fluid as it may precipitate coning.

Cisternal Puncture

This may be done if there is a contraindication to performing lumbar puncture (suppuration, disease or deformity of the spine).

It may be useful to compare pressures and composition of CSF obtained by lumbar and cisternal punctures in case of spinal block.

A dye can be injected through a cisternal puncture to delineate the upper border of a spinal tumour when it is not possible to do so with lumbar myelography.

Pericardiocentesis

Indications

1. Diagnostic (cytology, culture of fluid)
2. Therapeutic (for relief of cardiac tamponade).

Needle

A pleural aspiration needle is used.

Procedure

- This is done under ECG and ECHO monitoring.
- The procedure is carried out under strict aseptic precautions.
- If the patient is anxious, 10 mg of IV diazepam may be used.
- Different sites can be chosen to perform the procedure.

1. Xiphisternal or Epigastric Route

- It is the safest and recommended route.
- The patient is made to recline comfortably with a back rest at an angle of 45°.

- The skin and deep tissues are infiltrated with 10 ml of 2% lignocaine solution.
- The needle is pushed in posteriorly at an angle of 45° to the skin in the direction of the left shoulder.
- As the skin and subcutaneous tissue is pierced, the resistance due to diaphragm is felt. On piercing this, needle enters the pericardial cavity. Needle is then advanced slowly with suction applied to the syringe.
- Entry into the pericardial sac is confirmed when fluid is aspirated into the syringe. The needle is inserted further by about 5–7 cm and aspiration of fluid continued.
- If the needle is advanced too far, the myocardium will be felt knocking against the tip of the needle and will cause the needle to grate against the myocardium whereby a crunching sensation will be felt.

2. Apical Route

- The apical impulse is palpated. The needle is then inserted about 2 cm medial to the cardiac apex or if cardiac apex is not palpable, 2 cm medial to the lateral edge of cardiac dullness, in the 4th or 5th intercostal space.
- This route carries a greater risk of injury to the coronary arteries and contamination of the pleural space when the pericardial fluid is purulent.

3. Parasternal Route

The needle is introduced in the fifth left intercostal space just to the left of the sternum and aimed straight backwards. The internal mammary artery lies about 2 cm lateral to the sternal edge and the needle must pass medial to this and laceration of the artery is the main complication of this route. In huge pericardial effusion, same procedure can be done to the right of sternum. One more posterior approach is also possible.



Complications

1. Vasovagal reaction (bradycardia, hypotension)
2. Haemopericardium
3. Arrhythmias
4. Pneumopericardium
5. Pyopericardium
6. Contamination of pleural cavity
7. Injury to coronary, internal mammary arteries
8. Laceration of myocardium (ventricle), lung, oesophagus
9. Peritonitis.

Aftercare

- ECG monitoring is continued for further 2 hours.

- Pulse and BP is recorded every 15 minutes for 2 hours.
- A chest X-ray is taken if complications are suspected.
- Complications are uncommon after 2 hours.

Ascitic Fluid Aspiration (Paracentesis)

Indications

1. Diagnostic
2. Therapeutic (in cases of respiratory embarrassment due to tense ascites or removal of ascitic fluid when the liver is healthy).

Procedure

- An IV needle is used for the procedure.
- The patient is made to lie supine on a firm surface.
- The procedure is carried out under strict aseptic precautions.
- Any one of the various sites may be chosen for drainage of ascitic fluid.

The different sites that can be chosen are:

1. Midline (midway between pubic symphysis and umbilicus after emptying the urinary bladder).
2. Spinoumbilical line (junction of the medial 2/3rd and lateral 1/3rd of the spinoumbilical line).

In case of minimal ascites, a sitting posture may be adopted.

The IV needle used for aspiration is attached to a catheter which is attached to a collecting bag.

1–2 litres of fluid may be drained in one sitting over 4 hours. In case of liver disease, following each paracentesis, salt free albumin is infused intravenously to replace the loss of protein in the ascitic fluid.



Complications

1. Vasovagal attack
2. Hepatic encephalopathy
3. Peritonitis
4. Injury to the bowel or bladder
5. Persistent leakage through puncture wounds in malignant ascites.

Dry Tap

Omental patch occluding the tip of the needle.
Perforation of a viscus.

Aftercare

Patient should be monitored for 24–48 hours after aspiration to detect development of complications.

Bone Marrow Aspiration

Indications

1. Unexplained anaemias, granulocytopenia, thrombocytopenia
2. Aplastic anaemia
3. Leukaemias
4. Kala azar
5. Malaria
6. Partially treated enteric fever (bone marrow culture)
7. Bone tumours and myeloma.

Contraindication

Bleeding disorder.

Needles (Fig. 15.2)

There are 3 types of needles that can be used. They have a stylet and the length of the needle to be inserted into the marrow cavity can be adjusted with the use of a guard.

1. Salah's needle with side screw
2. Klima needle with central screw (will not slip)
3. Bone marrow trephine needle (Jamshidi-Swain or Islam needle for bone marrow biopsy).

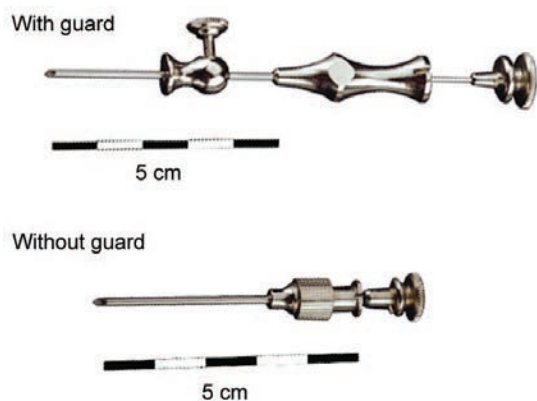

Fig. 15.2: Bone marrow aspiration needle

Procedure (Fig. 15.3)

The procedure can be done at any one of the following sites.

1. Sternal body or manubrium
 2. Posterior iliac crest
 3. Tibia (medial aspect just below the tibial tubercle)
 4. Spinous process of vertebra
 5. Site of bone infiltration or tumour.
- The posterior iliac crest and tibia are the preferred sites in children.

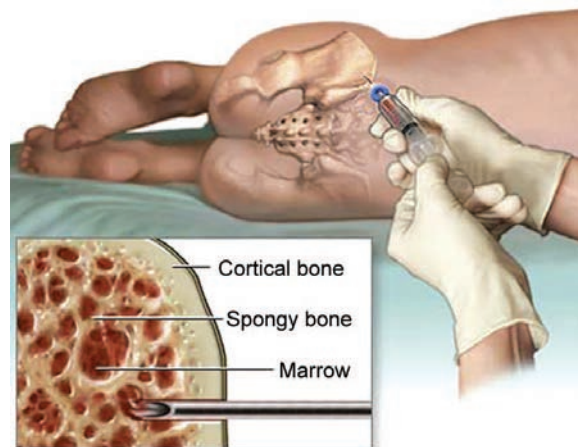

Fig. 15.3: Bone marrow aspiration

- The procedure is carried out under strict aseptic precautions.
- Local anaesthesia (5 ml of 2% lignocaine) is infiltrated from the skin upto the periosteum.
- The bone marrow needle is then pushed in through the skin and subcutaneous tissues up to the periosteum. The guard of the needle is adjusted so that only a further 5 mm can be advanced into the bone marrow.
- The needle is held at right angles to the bone and with firm pressure and a clockwise counterclockwise action pushed through the outer cortex until a sensation of decreased resistance is felt when the marrow cavity is entered. The stylet is removed, a 10 or 20 ml syringe is attached to the needle, and with sharp suction up to 0.5 ml of marrow is aspirated into the syringe to avoid mixing with peripheral blood. While aspirating, patient experiences an excruciating suction pain indicating that the needle is in the marrow.
- If no marrow is aspirated the needle is rotated or the stylet replaced and the needle cautiously advanced or retracted. If marrow is still unobtainable, a different site is chosen.
- Slides must be well cleaned and readily available for making immediate smears. Bone marrow particles can be seen in the smear of the aspirate.
- A drop of aspirate is placed on the slides from which blood can be removed using a syringe with fine needle. The remaining material can be smeared so as to get a pure bone marrow smear. Alternatively the material can be placed in a watch glass with EDTA from which blood can be removed using Pasteur's pipette and the remaining bone marrow particles can be smeared.

- Good smears are obtained by placing a drop of aspirate 1 cm from the end of a clean slide. By using a second smooth slide, a 3 to 5 cm film is made from the particles. The particles should leave a trail of cells.
- A minimum of 10 slides should be made and stained immediately.

Dry Tap

1. Faulty technique
2. Hypoplasia/aplasia of bone marrow
3. Tightly packed marrow
4. Myelofibrosis.



Complications of Sternal Puncture

1. Injury to the underlying large vessel or heart in the sternal approach leading to fatal haemorrhage.
2. Pericardial tamponade
3. Mediastinitis
4. Pneumomediastinum.

Trephine Biopsy

The posterior iliac crest is the preferred site for performing trephine biopsy. The patient is placed in the right or left lateral position with the back comfortably flexed, and the medial expansion of the uppermost crest is chosen.

The skin overlying the crest is incised with a scalpel. The needle is then introduced with stylet in place with a boring motion (clockwise and counterclockwise) in the direction of anterior superior iliac spine until there is a decrease in resistance. Stylet is removed and the needle is further advanced till 2 to 3 cm of marrow is obtained. Marrow specimen is removed with the distal cutting edge of the needle. The instrument containing the specimen is withdrawn by rotation along its axis with quick full twists. Smear must be made immediately and stained with eosin and hematoxylin after decalcification.

A part of the biopsy material can be utilised for Leishman's stain. In trephine biopsy, histology is well delineated and myelofibrosis can be confirmed.

Liver Biopsy

Indications

1. Unexplained hepatomegaly/hepatosplenomegaly
2. Infiltrative disorders (sarcoid, malignancy, granulomatous lesions, lymphomas, storage disorders like haemochromatosis and Wilson's disease)

3. Pyrexia of unknown origin
4. Carcinoma (suspected hepatoma or metastasis)
5. Cholestasis of uncertain origin
6. Persistent abnormal liver function tests
7. Cirrhosis
8. Chronic hepatitis (chronic active hepatitis, chronic persistent hepatitis, chronic lobular hepatitis)
9. Alcoholic liver disease.

Contraindications

1. Bleeding disorder
2. Known hepatocellular malignancy
3. Unwilling or uncooperative patients.
4. Presence of tense ascites (may lead to continuous leak)
5. Dilated biliary radicle (may lead to bile peritonitis)
6. Vascular tumours
7. Infected right pleural space or septic cholangitis.

Liver Biopsy Needles

1. Menghini's needle (aspiration needle)
2. Vim Silverman's or Klatskin needle (cutting needle)
3. Trucut biopsy needle.

Procedure

The patient should be adequately prepared before performing liver biopsy.

Injection vitamin K one ampoule is given intramuscularly daily for 3 consecutive days before the procedure.

Blood grouping and cross-matching of the patient's blood must be done and a bottle of compatible blood should be kept in readiness at the time of procedure.

Caution

The procedure should not be performed when

1. Prothrombin time is prolonged > 3 sec. above the control.
2. Platelet count < 50,000/cmm
3. Bleeding time, clotting time or partial thromboplastin time is prolonged.

1. Menghini's Needle

- The tip of the needle is not bevelled. A separate track making needle is present. A small guard with a head and flattened stalk which fits in with the barrel of the base of the needle. Since it is flattened and not circular, it can allow free flow of blood and saline and not the biopsied material.
- The patient lies along the edge of the bed in the supine posture.

- The biopsy may be performed in the 8th or 9th intercostal space in the mid axillary line, or one intercostal space below that of liver dullness obtained in full expiration in the mid axillary line.
- The procedure is carried out under strict aseptic precautions.
- The procedure is performed under local anaesthesia.
- A track is made in the subcutaneous tissue up to the liver (not in the liver) with the track making needle. The patient is asked to hold his breath in expiration and the Menghini's needle with the guard on and with a saline filled syringe is passed through the readymade track. Before entering into the liver, the unwanted tissue that would have entered the needle, should be syringed off by pushing saline. With suction on, the needle must be pushed into the liver and withdrawn immediately like a bonnet drill.
- Now the liver tissue is inside the biopsy needle and the same can be pushed into a bottle with formalin by injecting saline in the syringe. A cord like liver tissue can be obtained if the liver is not cirrhotic.
- The success rate of the procedure using this needle is approximately 75%.

2. Vim Silverman's Needle

This is a larger needle and has a stylet, barrel and biforked biopsy blade which is longer than the needle and which has to be rotated to 180° to get a good biopsy material. The advantage of this needle is that it has a success rate of approximately 95%. The disadvantage is that it is more traumatic.

3. Trucut Needle

It has a trocar and cannula. The trocar is longer than the cannula.

The skin is nicked with a scalpel blade and the biopsy needle is advanced slowly with the patient breathing quietly. The needle is advanced till it begins to swing with respiration. The needle is then slightly withdrawn until it stops swinging. The patient is then instructed to hold his breath in expiration and the needle is thrust for about 2 to 3 cm into the liver. The inner trocar is advanced holding the outer cannula with the cutting sheath still. The outer cutting sheath is then advanced over the inner trocar to cut the liver in the biopsy notch. The needle (trocar and cannula) is then quickly withdrawn after completing the procedure.

Aftercare

The patient is instructed in to lie on the right side for four hours and to remain in bed for 24 hours.

Pulse rate and blood pressure are recorded hourly.



Complications

1. Shock is usually caused by rapid loss of blood from a large vessel or vascular tumour
2. Severe pain may be caused by bleeding or leakage of bile. Pain may be referred to the shoulder tip
3. Septicaemia may result from needling an infected bile duct or liver abscess
4. Pneumothorax
5. Biliary peritonitis (injury to gallbladder)
6. Bacterial peritonitis (injury to hepatic flexure of colon).

Kidney Biopsy

Patients with renal glomerular disease may present with similar clinical features yet have conditions ranging from trivial to life threatening. Their prognosis and treatment depend on the renal pathology, and histological examination of the kidney is often the only way to make the diagnosis.

Needle biopsy provides a sample of about 20–30 of the 2,000,000 glomeruli and so is unhelpful and may give misleading results in patchy conditions such as reflux nephropathy. It is most valuable in assessing and, in particular, indicating the prognosis of patients with diffuse glomerular disease.

Contraindications

Laceration of the kidney may cause haemorrhage, which may lead to nephrectomy. The risk is small and biopsy should be done only if the other kidney is normal.

A single kidney or major abnormality of the contralateral kidney are contraindications, in the presence of any haemorrhagic tendency, including advanced uraemia. The platelet count should be over 1,00,000/mL and the prothrombin time must be normal.

Biopsy should not be done on shrunken kidneys because they are difficult to locate, the histological findings are often non-specific, and the results are unlikely to provide information of any therapeutic relevance.

Procedure

Before starting the procedure, grouping and cross-matching of the patient's blood must be done and a bottle of compatible blood should be kept ready.

The procedure should be explained to the patient, and patient should practice holding his breath in inspiration. Biopsy is unsafe if patient cannot cooperate. Informed consent may be obtained in writing.

Indications

<i>Clinical syndrome</i>	<i>Indications for biopsy</i>
Asymptomatic proteinuria	Protein excretion more than 1 g/24 h Red blood cells in urine Impaired renal function
Haematuria-macrosopic and microscopic Acute nephritic syndrome Nephrotic syndrome	Urography and cystoscopy do not show source of bleed Persisting oliguria <i>Adults:</i> Unless cause is apparent from extrarenal manifestations. <i>Children:</i> Only if haematuria also present, or if proteinuria persists after trial of corticosteroid
Acute renal failure	No obvious precipitating cause; Obstruction of the renal tract excluded
Chronic renal failure Renal allograft	Radiographically and ultrasonographically normal kidneys To differentiate rejection from cyclosporine toxicity and to diagnose recurrence of original disease

Renal biopsy is potentially hazardous.

Premedication with intravenous diazepam makes the procedure less unpleasant for the patient; general anaesthesia is required only for infants and young children.

The patient is placed in the prone position. Biopsy may be done under ultrasound guidance. The site of choice is the edge of the lower pole of the left kidney. This avoids major renal vessels and is likely to contain more cortex than medulla. The radiologist marks the surface anatomy on the skin and information of the depth of the kidney from the skin is given.

The skin is prepared and the skin and subcutaneous tissues are anaesthetised. An exploring needle is then inserted into the lumbar muscles and then advanced 5 mm at a time until a definite swing with respiration show that the point is within the kidney. The patient is asked to hold his breath in inspiration each time the needle is advanced. After locating the kidney the local anaesthetic is injected along the track formed, while withdrawing the needle.

A 11.4 cm trucut needle is used for obtaining the biopsy specimen. A nick is made in the skin with the point of a scalpel blade and then the biopsy needle is advanced towards the kidney.

The cannula of the biopsy needle is closed over the obturator. The obturator is longer than the cannula and has a bevelled edge. After introduction of the biopsy needle, the appearance of a large arc of swing of the needle indicates that the kidney has been located. With the tip of the needle just within the kidney, the patient is asked to hold his breath in inspiration. The obturator is pushed in and the cannula is then pushed over the length of the obturator, to cut the specimen. The

obturator handle is kept firmly fixed with one hand while the cannula is pushed in with the other hand. The obturator and the cannula are withdrawn after completing this procedure.

A successful biopsy produces a strip of kidney up to 20 mm long. The specimen is divided into three portions. One portion is sent for light microscopy examination, the second portion for electron microscopy examination and the third for immunofluorescent microscopy.



Aftercare and Complications

- The patient should remain in bed for 24 hours.
- Pulse and blood pressure are checked every hour for four hours and thereafter for every four hours.
- The most important complications of renal biopsy is haemorrhage, which may be perirenal, causing joint pain and sometimes a palpable mass as well as signs of blood loss.
- There may be persistent heavy haematuria and sometimes clot retention.
- Minor haematuria is common and usually settles quickly. Continuing haemorrhage should be treated by blood transfusion.

Setting up a Drip

Indications

1. Replacement of fluids (blood products, colloids or electrolyte solutions).
2. To provide a route for administering intravenous medication or nutrition.
3. Monitoring of central venous pressure.

Precautions

1. No absolute contraindications exist, but particular care is needed in some circumstances: In presence of incipient heart failure an extra circulating fluid load may result in severe pulmonary oedema. If a blood transfusion or intravenous infusion is essential this problem may be alleviated by giving diuretics simultaneously.
2. In presence of renal failure it is important that the fluid and electrolyte loads, as well as the amount of drugs given, do not exceed the excretory capacity of the kidney.
3. In patients with impaired immune responses or damaged heart valve, a drip site is an important portal for the entry of potentially fatal infection.
4. If small veins with inadequate blood flow are cannulated, inflammation may occur at the venepuncture site.

Procedure

Choice of Vein

The most convenient site for peripheral cannulation is the non-dominant forearm (left forearm in a right handed individual and vice versa). This permits comfortable mobility of the dominant arm and allows the dominant arm to carry out activities like writing, eating, etc.

Veins of the elbow should be avoided if possible, as the cannula is difficult to fix firmly, and uncomfortable immobilisation of the joint is required. The dorsum of the hand is a convenient site. Veins near the ankle may be used in a restless patient as the leg is often easier to immobilise. Other sites of cannulation are the jugular, subclavian, or saphenous veins.

Venepuncture

Clothing is removed from the limb and a tourniquet is applied to occlude venous return. A suitable superficial vein is selected and the area around the chosen site should be cleaned well with an alcohol swab.

The needle is pierced through the skin parallel to the vein chosen to be cannulated, with the bevelled edge facing upwards.

The vein is then pierced by moving the needle in the direction of the vein and continued for a distance in the lumen of the vein.

The tourniquet is then released and the IV fluid set is connected and allowed to flow into the vein. The rate of flow of the fluid is controlled by use of an adjustable valve attached to the IV set.

The fluid or blood is usually present in a collapsible plastic bag. If the fluid is present in a rigid bottle, an air

inlet tube will be required to prevent the formation of a vacuum when fluid flows out of the bottle into the IV set.

The site of cannulation is firmly fixed with adhesive plaster. A segment of the tube of the IV set close to the needle is folded upon itself into a loop and fixed so as to allow free movement of the limb cannulated.

Problems

When no veins are visible or palpable, a 'blind' cannulation of the jugular or subclavian vein may be performed.

Alternatively, a 'cut down' procedure may be employed.

A small incision is made at the elbow or ankle and, with a tourniquet on the limb, a vein is displayed by blunt dissection of subcutaneous tissue and is under direct vision.

Appearance of inflammation at the site of cannulation is an indication for prompt removal of the cannula. The local infection will not clear or respond to treatment as long as the foreign material is present. Persistent infection may lead to bacteraemia.

An unexplained fever in a patient with a drip is often due to inflammation at the venepuncture site.

Administration of Intravenous Cytotoxics

The administration and management of intravenous cytotoxic drugs is a specialist's task, requiring extensive knowledge and practical experience about the pharmacology, toxicology, and effectiveness of these drugs.

Procedure

Patient should be adequately informed about the procedure to be adopted and also of the side effects that may be expected as a result of cytotoxic drug administration.

The needle is introduced into the vein as explained above. The patency of the vein and the needle is confirmed by injecting about 5–10 ml of isotonic saline and watching the vein carefully. A large vein, preferably on the dorsum of the hand is selected. Cytotoxic drugs should never be injected into the veins of the leg.

After injecting the drug, flushing with isotonic saline is done to prevent the drug from leaking from the puncture site.

Contraindications for Cytotoxic Therapy

1. Low RBC, WBC or platelet count. A fresh blood count should always be obtained before administering cytotoxic drugs.

2. Dysfunction of an organ which may be worsened by the cytotoxics to be used or which is the organ of excretion for that drug. For instance, cisplatin, a renal toxic drug, should be avoided in renal failure.
3. Known hypersensitivity to the cytotoxic drug.
4. Presence of infection, whereby administration of the cytotoxic drug may be postponed.

Problems

Extravasation

Many cytotoxics are very vesicant and if they extravasate they may cause severe tissue damage. If, despite careful administration, extravasation does occur, the injection is stopped immediately and the following procedure is adopted.

- a. Withdraw any remaining drug by aspirating through the needle.
- b. Instillation of 50 mg hydrocortisone into the site of cannulation via the IV needle.
- c. Removal of the IV needle and instillation of a further 50 mg of hydrocortisone subcutaneously into the swollen area.
- d. Analgesics may be administered in the presence of severe pain.

Local Reactions

Redness and irritation sometimes develop along the vein being injected as a local reaction to the drug, especially when small veins are used. This may be reduced by further dilution, achieved, for example, by injecting the drug into a fast flowing infusion or injecting it more slowly. Intravenous hydrocortisone may be used at the end of the procedure.

Pain on Administration

Some drugs (especially dacarbazine, vinblastine, and mustine) cause muscular and venous pain on administration. This pain is felt along the vein and not just at the site of the needle, and so is different from that caused by extravasation. Further dilution or injection into a fast running infusion often alleviates the problem.



Complications

Many cytotoxic drugs cause severe emesis. It is therefore mandatory to ensure a good antiemetic cover prior to administration of the cytotoxic drug.

Cytotoxic therapy may culminate in bone marrow depression causing infection and fever. Patients with a suspected potential infection should have an immediate

blood count performed. Sepsis in presence of neutropenia is an emergency and urgent measures should be adopted for its treatment.

Patients may develop severe stomatitis and should be advised on proper oral hygiene.

Metabolites of some cytotoxic drugs like ifosfamide and cyclophosphamide may cause a chemical cystitis and patients should therefore be advised on adequate fluid intake.

Percutaneous Central Venous Cannulation

Central venous pressure is the resultant of venous blood volume, right ventricular function and venous tone. Rapid changes in blood volume, especially associated with impaired right heart function, is the most common reason for monitoring central venous pressure.

Infusion of antibiotics, chemotherapeutic agents, and other substances irritant to veins and tissues are best administered through a line whose tip lies in a central vein.

Drugs used in resuscitation of cardiac arrest should be given through a central line if one is available.

This route is also widely used for long-term intravenous alimentation.

It is also used for insertion of a Swan-Ganz catheter to monitor the pulmonary artery and left atrial pressure and also for introduction of intracardiac pacing devices.

Venepuncture should be avoided at any site in which there is sepsis.

Apical emphysema or bullae contraindicate infraclavicular or supraclavicular approaches to the subclavian vein.

A carotid artery aneurysm precludes using the internal jugular vein on the same side.

Procedure

Strict aseptic precautions should be observed during the insertion of the cannula.

Equipments

One of the following equipments may be used.

1. *Catheter through cannula*: Cannula on the outside of a needle is placed in the vein and the needle is withdrawn. A catheter is then inserted into the vein. When the catheter is in position the cannula is withdrawn.
2. *Catheter over needle*: The needle and the catheter are placed in a arm vein. The needle (which is attached to a wire) is withdrawn, and the catheter advanced into position.

3. *Catheter over guide wire*: A flexible guide wire is inserted into the vein through a needle. After removal of the needle the catheter is inserted over the wire, which guides it into the central vein.

Methods of Insertion

Arm veins: A tourniquet is applied on the limb. If the patient is conscious the skin should be infiltrated with a local anaesthetic.

The median (basilic) arm veins are the safest approach to the central venous system. The catheter to be introduced through the vein should have a minimum length of 600 mm.

External jugular vein: The external jugular vein runs from the angle of the mandible to behind the middle of the clavicle and joins the subclavian vein. The patient is placed in a 20° head down position with the head turned to the opposite side. In this position the external jugular vein becomes prominent and can be cannulated.

Internal jugular vein: The internal jugular veins run behind the sternomastoid close to the lateral border of the carotid artery. The vein may be cannulated with a low incidence of major complications by an approach well above the clavicle. The patient is placed in a 20° head down position with the head turned to the opposite side. The right side is preferred to avoid injury to the thoracic duct. The sternomastoid muscle, cricoid cartilage, and carotid artery are identified. With the other hand the carotid artery is palpated and protected at the level of the cricoid cartilage. The needle is attached to a saline filled syringe and inserted just lateral to the artery. The needle is directed towards the feet. Gentle aspiration is maintained as the needle is advanced. A flush of blood into the syringe signifies entry into the vein. The cannula is then introduced towards the central vein.

Infraclavicular subclavian vein: The subclavian vein is particularly suitable for administering long term parenteral nutrition.

It is widely patent even in states of circulatory collapse, so that subclavian venepuncture may provide the only route for rapid infusion.

Puncture and catheterisation of the subclavian vein is a blind procedure, and so may result in complications, most common being pneumothorax.

Subclavian vein lies in the angle formed by the medial one-third of the clavicle and the first rib, in which the subclavian vein courses over the first rib to enter the thoracic cavity.

The patient rests supine, tilted 20° head down. Either side may be used although the right side is preferable. The patient's head is turned to the opposite side. The midpoint of the clavicle and the suprasternal notch should be identified.

The needle is attached to a saline filled syringe and inserted below the lower border of the midpoint of the clavicle. The needle tip is advanced close to the under-surface of the clavicle, aiming at the suprasternal notch. While the needle is advanced, gentle suction should be maintained on the syringe, and a flush of blood indicates that the vein is entered. The cannula is then passed into the vein.

A chest radiograph should always be taken after the procedure to check for pneumothorax.

Checking after Insertion of Cannula

Blood should be aspirated to ensure that the catheter is in a vascular space before injecting fluid. If the line is connected to a bottle of fluid that is lowered below the patient, blood should flow freely under the influence of gravity.

Diameters of Needles or Cannulae and Lengths of Catheters Recommended for Each Route of Insertion

Route of insertion	Outside diameter of needle or cannula	Minimum length of catheter (mm)
Arm vein	14 G	600
External jugular vein	16 or 14 G	200
Internal jugular vein	16 or 14 G	150
Subclavian vein	16 or 14 G	150

Complications

Immediate	Immediate or late	Late
a. Arterial puncture	a. Air embolism	a. Myocardial perforation and tamponade
b. Cardiac arrhythmias	b. Catheter embolus	b. Hydrothorax
c. Injury to thoracic duct	c. Pneumothorax	c. Infection
d. Injury to nerves		d. Venous thrombosis

On connecting to a column of fluid for measurements of central venous pressure the fluid column should show slow oscillations related to respiration and quicker oscillations related to the heart beats.

A chest radiograph should be taken to confirm that the position of the tip is above the right atrium, preferably not more than 2 cm below a line joining the lower borders of the clavicles.

Maintenance of Central Venous Cannulation

Once satisfactorily placed, the catheter should be fixed carefully to prevent inadvertent withdrawal or movement further into the vein.

Strict aseptic precautions should be maintained. The IV set should be changed daily. Injecting drugs into the venous catheter or taking blood samples through it should be avoided. Regular bacteriological monitoring of the venepuncture site should be carried out. If an infection occurs, the catheter should be removed immediately.

It is important to maintain a continuous flow through the catheter to prevent reflux of blood and clotting. After making intermittent measurements of venous pressure, using a simple manometer filled with saline solution, the infusion should be turned on. In case of clot formation, it may be possible to clear the catheter by injecting 2–5 ml heparinised saline under pressure.

Passing a Nasogastric Tube

There are two main indications for passing a nasogastric tube. One is to aspirate stomach contents, as in 'acute abdomen' and the other is to maintain nutrition of the patient.

A large nasogastric tube (size 16 FG) may be used for aspiration and a smaller nasogastric tube (size 3 mm diameter) may be used for feeding.

Procedure

The procedure is explained to the patient in order to obtain maximum cooperation from the patient. The patient may be seated in a reclining posture with the head bent slightly forwards.

The nose is lubricated with lignocaine jelly via an applicator. The nasogastric tube is also lubricated with lignocaine jelly and passed along the floor of the nose. Resistance is felt as the tip reaches the nasopharynx. At this point the patient is asked to swallow his saliva or small feeds of water may be given. This helps to advance the tube into the oesophagus without resistance. Never

force the passage of a nasogastric tube if persistent resistance is encountered.

At 40 cm, in the adult, the gastro-oesophageal junction is reached.

The tube is passed beyond this junction. It is now essential for the confirmation of the presence of the tip of the tube in the stomach. This is done by aspirating fluid through the nasogastric tube and confirming its acidic nature by litmus paper test.

If no aspirate is obtained, a radiograph to confirm the tip of the nasogastric tube may be taken.

Insufflation of air with simultaneous auscultation over the epigastrium is an additional confirmatory sign.

The tube outside is then closed with a stopper and anchored on the forehead with an adhesive tape.

Problems

Choking usually indicates the tube has entered the trachea and should be withdrawn immediately.

Difficulties in passing the tube may occur at any point along the route.

- a. *Nose*: If one nostril is narrowed by a deviation of the nasal septum, the other nostril is used to pass the tube. In the event of persistent difficulty in passing the tube, a topical vasoconstrictor (0.5% ephedrine) may be introduced into the nostril to facilitate passage of the tube.
- b. *Oropharynx*: Reflex gagging by the patient may direct the tube into the mouth. This problem may be tackled by
 - i. Withdrawing the tip of the tube into the nasopharynx and reintroducing it again into the oropharynx.
 - ii. Cooling the tube in the refrigerator to stiffen it so that it is less likely to coil.
 - iii. Observing the passage of the tube through the mouth with a depressor on the tongue and using a pair of long forceps to guide the tube down.
- c. *Oesophagus*: A stricture or pharyngeal pouch may prevent the tube from passing.

Aftercare and Complications

Most fine bore tubes can be left in place for several weeks, but they have been known to coil in the stomach and re-enter the oesophagus.

The visible tube markings are checked regularly to detect insidious slipping out of the nasogastric tube.

The main complications of the procedure arise from passage into the bronchial tree, or perforation of the pharynx or oesophagus. Perforation of the oesophagus

is increased by the presence of oesophageal disease or cardiomegaly.

Urethral Catheterisation

Indications

Temporary catheterisation is indicated as an emergency measure to relieve the pain of acute retention. This is commonest in men with prostatic disease and bladder outflow obstruction, but it can also be due to clotting of blood in the bladder, urethral stricture, the failure of sphincter relaxation associated with post-operative pain, or in neurogenic bladder.

A catheter also allows accurate measurement of urine output after major surgery. Catheterisation to assess hourly urine output is helpful in assessing the fluid loss in uncooperative or comatose patients with intravascular volume contraction.

Catheterisation is also indicated in an unconscious or a conscious female with stroke who is bed bound.

Prolonged catheterisation is best avoided but may be necessary in a few male patients with prostatic enlargement, who are unfit for prostatectomy. Some patients with neurological problems, such as multiple sclerosis, or spinal trauma, may require prolonged catheterisation.

Contraindications

Catheterisation is best avoided when urethral injury is suspected.

Urinary tract infections are very difficult to eradicate in the presence of a catheter, and so if a patient has an infection, an indwelling catheter should be avoided when possible.

Choice of Catheters

If catheterisation is done to drain the bladder as a temporary measure, and then removed, a non-retaining urinary catheter like the Gibbon's catheter may be used.

If catheterisation is done with intention to retain the catheter for few days, a self retaining catheter like the Foley's catheter may be used.

If catheterisation is to be performed in the presence of associated haematuria, a three way catheter, with an additional channel to run in sterile fluid for irrigation and removal of clots in the catheter lumen may be used. This is otherwise known as 'haematuria catheter'.

The catheters are usually made of 'latex' to make it as biologically inert as possible. If a catheter is to be kept in place for more than a few days, a silicone catheter is preferred.

A very large catheter has a tendency to damage the male urethra by causing periurethritis and later stricture formation. A very fine catheter may be easily clogged by blood or debris. It is, therefore, best to choose a catheter of medium size.

The urinary catheters are sized using the system invented by Charriere and sometimes called French gauge. The Charriere gauge is defined by the circumference of the catheter in millimeters. A 14 Charriere catheter is a good first choice in an uncomplicated case.

Procedure

The procedure is explained to the patient.

The procedure is carried out using strict aseptic precautions.

The urethra is anaesthetised using 15–20 ml of 2% lignocaine jelly. In man, after the anaesthetic gel has been installed, it should be massaged carefully down the urethra by stroking down the anterior surface of the penis.

Catheterisation in Males

Sterile gloves are used by the examiner and the penis is swabbed with antiseptic solution. The foreskin, if present, is retracted and cleansed as well. The penis is held upwards, and the tip of the catheter is inserted into the meatus. The catheter is passed gently down the urethra until it reaches the penoscrotal junction. The tip of the catheter now rests against the external urethral sphincter. By pulling the penis downwards between the patient's thighs at this stage, the natural curves of the urethra can be straightened and the catheter can be advanced without difficulty through the sphincter and prostatic urethra into the bladder. At this stage urine normally flows through the catheter confirming its right positioning. If no urine appears, and the catheter seems to be inserted correctly, flushing of the catheter to remove any blocks in the lumen may result in normal urine flow.

After confirmation of position of the catheter in the above manner, the balloon is inflated to retain the catheter in the bladder.

The retracted foreskin of the penis is replaced to avoid danger of paraphimosis.

The catheter is then attached to a sterile drainage bag.

Catheterisation in Females

The female urethra is comparatively short and straight and catheterisation is not usually difficult.

The patient should be asked to lie with her thighs apart and her knees comfortably flexed. After introduction of the local anaesthetic gel into the urethra

and after swabbing the perineum with an antiseptic solution, the external urethral meatus is exposed by separating the labia. The urethral opening is identified and the catheter is introduced.

Problems

If the patient is tense or insufficient time has been allowed for the topical anaesthetic to take effect the catheter may be held up because of spasm of the urethral sphincter. If the patient is asked to try gently to void when the catheter tip reaches it, the sphincter may relax sufficiently to let the catheter through.

When the balloon of a Foley's catheter is blown up the patient should feel no pain. Pain suggests that the balloon is being inflated in the urethra. If this occurs the balloon must be deflated and the catheter repositioned.

There may be a failure of the catheter balloon to deflate when the catheter removal is attempted. The best way to deal with this problem is to use a fine wire stilette introduced down the inflation channel to burst the balloon. If this fails ultrasound guided percutaneous needle puncture of the balloon is recommended.

An indwelling catheter almost always leads to a urinary tract infection within days or weeks. The effects of this can be minimised by regular bladder washouts with saline or dilute chlorhexidine solution. When an infection is established, even the most intensive antibiotic treatment is unlikely to make the urine sterile until the catheter is removed. Long term catheterisation is commonly associated with the formation of stones in the bladder.

The Specimen

It is important to record the volume of urine drained from the bladder after introduction of the catheter. A sample of the urine drained is sent to the microbiology lab for analysis.

Arterial Puncture

This is done to measure arterial blood gas tension (PaO_2 , PaCO_2), oxygen saturation (SaO_2) and pH.

Contraindication

Bleeding diathesis (platelet count $< 30,000/\mu\text{L}$).

A relative contraindication is diastolic BP > 120 mm Hg.

Site of Puncture

The brachial artery just above the elbow crease of the nondominant arm (left arm in a right handed individual) is preferred.

Second preference is the radial artery.

Avoid the femoral artery since the femoral vein is larger than the artery and often blood is drawn from the vein, which gives erroneous results.

Procedure

A heparinised syringe is used (1 cc containing 1000 units). Aseptic precautions are used. Local anaesthesia is given at the site of puncture. The brachial artery is felt just medial to the biceps tendon. To prevent injection of lignocaine into the artery, always apply suction to the syringe before injecting the local anaesthetic.

With the bevelled edge facing upwards, the needle is advanced towards the brachial artery, with constant suction applied to the syringe. As the blood enters into the syringe, it may be seen to pulsate into the syringe with its own force. About 5 to 6 cc of the sample is adequate.

After the procedure, apply firm pressure over the site of puncture with a sterile gauze, and apply a crepe bandage over it.

Blood sample is then injected directly into the blood gas electrodes from the syringe without transferring it into any other container. Blood gas analysis should be carried out within 5 minutes. If a delay is inevitable, cooling the syringe and its contents in ice with subsequent rewarming to body temperature before analysis is done in order to minimise errors caused by continued metabolism of the white cells within the blood sample.

Tracheostomy

Tracheotomy means making an opening into the trachea. *Tracheostomy* means converting this opening to a stoma on the skin surface.

Indications of Tracheostomy

1. Relief of upper airway obstruction (foreign body aspiration, acute epiglottitis, acute laryngeal oedema).
2. Bronchial toilet to remove excessive bronchial secretions as may occur in coma, CVA, head injury, drug overdose, cervical cord lesions, myaesthesia gravis or tetanus.
3. To reduce dead space by 30 to 50% and improve respiratory efficiency.
4. It may be required when there is need for prolonged assisted ventilation.

Types of Tracheostomy

1. *Elective temporary tracheostomy*: It is a planned procedure done under general anaesthesia as a

temporary stage in the management of reversible problems like acute epiglottitis.

2. *Permanent tracheostomy*: This procedure involves removal of the larynx (laryngectomy or laryngopharyngectomy) with the tracheal remnant being brought out to the surface as a permanent opening to the respiratory tract.
3. *Emergency tracheostomy*: This procedure is not preferred. It has only a very few indications like a large laryngeal tumour requiring emergency relief of the obstruction.

Tracheostomy Tubes

1. *Silver Jackson tube*: It is used for temporary tracheostomy and has an inner and an outer tube.
2. *Portex tube*: There is only one tube and may be cuffed or uncuffed.
3. *Redcliffe tube*: It is a single right angled tube useful in patients with a thick and fat neck.

Procedure

1. Elective Tracheostomy

The patient is positioned with a sandbag or pillow under the shoulders in order to extend the neck and bring the trachea forwards. A horizontal incision is made through the skin and subcutaneous tissue down to the muscles. The incision is made about 2 fingers breadth above the sternum. The muscles are retracted on either side with retractors. The pretracheal fascia is identified and a vertical incision is made through it between the third and fourth tracheal rings.

A semicircular wall of the trachea is removed from either side and a tracheostomy tube is inserted through this defect. The wound is closed loosely with 4/0 silk sutures.

2. Emergency Tracheostomy

Patient is positioned in a similar manner as in elective tracheostomy. One percent lignocaine is infiltrated from the cricoid cartilage to the manubrium of sternum, which is the line of incision. A 6 cm vertical incision is made in the midline. Dissection is carried on in the vertical plane upto the trachea. The first tracheal ring is palpated and a horizontal incision is made at the level of the second tracheal ring. A semicircle of tracheal wall is removed and the tracheostomy tube inserted.

Postoperative Care

1. Good nursing care with strict aseptic precautions.
2. There is increased secretion formation in the first 48 hours after the procedure and needs to be

removed every 1/2 hour for 48 hours and thereafter for every 1 to 2 hours.

3. Humidification is necessary to prevent crusting of secretion and is done by instilling normal saline drops down the tracheostomy tube at regular intervals.
4. The tracheostomy tube should not be disturbed for the first 48 hours and thereafter the inner tube is cleaned at regular intervals.

Removal of Tube

The tracheostomy tube can be removed once the patient can sleep for a night with the tube corked.



Complications

1. Surgical emphysema around the root of the neck and upper chest due to tight suturing of the tracheostomy tube. This may lead to mediastinal emphysema if not relieved promptly.
2. Block of tracheostomy tube may occur if there is improper humidification or poor toileting.
3. Tracheal erosion and haemorrhage.

Endotracheal Intubation

This is an emergency procedure for providing adequate ventilation in cases of respiratory failure.

Types of Endotracheal Tubes (Fig. 15.4)

1. *Oral*: These are larger tubes of sizes 8, 9, and 10 that are passed orally.
2. *Transnasal*: These are smaller tubes of sizes 6 and 7 and are passed through the nasal cavity.

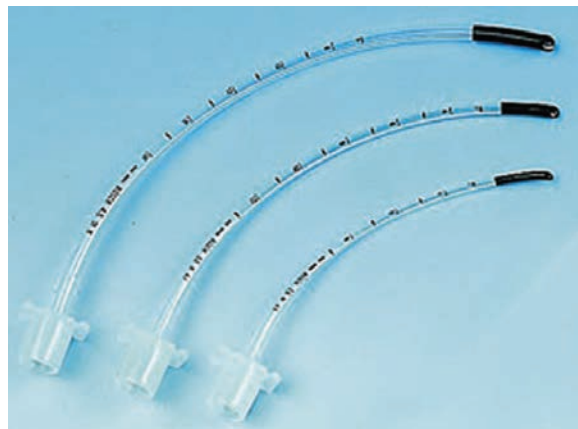

Fig. 15.4: Endotracheal tubes

Oral vs Transnasal Intubation

<i>Oral</i>	<i>Transnasal</i>
<ol style="list-style-type: none"> 1. Easy to perform 2. Whole procedure done under direct visualisation 3. Tubes may be bitten or extruded by use of tongue or lips 4. Larger tubes can be passed 5. Suitable for short term ventilation (24-48 hours) 	<p>Difficult to perform</p> <p>Initial part of procedure is blind</p> <p>Epistaxis may occur</p> <p>Only small tubes can be passed</p> <p>Suitable for long-term ventilation</p>

- The sizes of the tubes indicate their internal diameter in millimeters.
- Endotracheal tubes may be cuffed or uncuffed. Cuffed endotracheal tubes are preferred as they keep the tube in position.

Procedure

Oral Intubation

The patient is positioned supine with his neck extended.

Visualisation of the oropharynx, nasopharynx and vocal cords is done using a laryngoscope blade. The lateral flange of the blade is placed on the lateral aspect of the tongue so as to deflect the tongue to one side and obtain proper visualisation.

The endotracheal tube of appropriate size is then introduced into the trachea through the vocal cords.

The cuffed endotracheal tube is then inflated with the aim to keep the tube in position.

Transnasal Intubation

This is a blind procedure initially when the tube is introduced through the nasal cavity.

The passage of the tube through the nasal cavity is facilitated by instilling 1% ephedrine drops in the nostrils. Presence of a deviated nasal septum or nasal polyps make the procedure difficult.

After entering the oropharynx, the tube can be guided through the vocal cords into the trachea by visualisation through a laryngoscope.



Complications

1. Intubation of either bronchus, usually the right, leads to collapse of the lung. This can be rectified by withdrawing the tube above the level of the carina
2. Obstruction to the tube because of blockage by secretions
3. Tracheal dilatation due to over-distention of the cuff leading to subsequent infection and stenosis.

Laboratory Reference Values

Serum Biochemistry

Albumin	3.5 to 5 gm/dl
Alpha fetoprotein	< 30 µg/L
Ammonia	80 to 100 µg/dl
Bilirubin (Total)	0.2 to 1 mg/dl
Direct	0.1 mg/dl
Indirect	0.8 mg/dl
Bicarbonate	20 to 30 mEq/L
Blood gas (arterial)	
pH	7.35 to 7.45
PO ₂	80 to 105 mm Hg
PCO ₂	35 to 45 mm Hg
Calcium	
Total	9 to 11 mg/dl
Ionized	4.5 to 5.5 mg/dl
Ceruloplasmin	25 to 50 mg/dl
Chloride	95 to 110 mEq/l
Cholesterol	
LDL cholesterol	< 100 optimal 100-129 near or above normal 130-159 borderline high 160-189 high > 190 very high
Total cholesterol	< 200 desirable 200-239 borderline high > 240 high
HDL cholesterol	< 40 low > 60 high
VLDL	35 to 100 mg/dl
Copper	75 to 150 µg/dl
Creatinine	0.5 to 1.2 mg/dl
Ferritin	
Male adults	25 to 250 ng/ml
Female adults	20 to 200 ng/ml
Folate	
Plasma	2 to 12 ng/ml
Red cell	150 to 600 ng/ml
Glucose fasting (plasma)	65 to 110 mg/dl
Glycated haemoglobin	4 to 8%
Homocystine	5 to 15 µmol/L
Iron	50 to 150 µg/dl
Transferrin saturation	25 to 50%

Lactate	0.7 to 1.4 mmol/L
Lipase	0 to 160 IU/L
Lipoprotein (a)	0 to 3 mg/dl
Magnesium	1.5 to 2.5 mEq/L
Myoglobin	20 to 85 µg/L
Osmolality	270 to 300 mOsm/kg
Phosphate	3.5 to 4.5 mg/dl
Potassium	3.5 to 5 mEq/L
Protein (Total)	6 to 8 gm/dl
Sodium	135 to 145 mEq/L
Triglycerides (fasting)	< 160 mg/dl
Troponin I	0-0.4 µg/L
Troponin T	0-0.1 µg/L
Urea nitrogen	10 to 20 mg/dl
Urea	20 to 40 mg/dl
Uric acid	3 to 8 mg/dl
Vitamin B ₁₂	300 to 900 pg/ml

Serum Enzymes

ALT (SGPT)	10 to 40 IU/L
AST (SGOT)	10 to 40 IU/L
Acid phosphatase	1 to 5 IU/L
Alkaline phosphatase	3 to 13 KA units/L (40 to 100 IU/L)
Amylase	30 to 180 IU/L
Creatine kinase	
Male	30 to 200 IU/L
Female	30 to 150 IU/L
MB fraction	< 10 IU/L (usually < 5% of total CPK)
Gamma glutamyl transpeptidase	25 to 75 IU/L
LDH	100 to 300 IU/L
5' Nucleotidase	5 to 15 IU/L

Haematologic Values

1. Bleeding time 5 to 10 minutes
2. Clotting time 10 to 15 minutes
3. Fibrin degradation products < 8 µg/ml
4. Fibrinogen 200 to 400 mg/dl
5. Partial thromboplastin time (activated) 25 to 35 sec.

6. Prothrombin time	10 to 15 sec.	Vanillyl mandelic acid	2 to 8 mg/day
7. Complete haemogram		Protein	0 to 150 mg/day
a. Haematocrit		Sodium	100 to 250 mEq/day
Females	35 to 40%	Urobilinogen	1 to 3.5 mg/day
Males	40 to 45%		
b. Haemoglobin			
Females	13 to 15 gm/dl		
Males	15 to 17 gm/dl		
c. RBC count			
Males	4.5 to 5.5 millions/ cmm		
Females	4 to 4.5 millions/cmm		
d. Mean corpuscular Hb	25 to 35 pg/cell		
e. MCHC	30 to 35 g/dl		
f. MCV	78 to 98 fl		
g. RBC life span	120 days		
h. WBC count			
Total count	4000 to 11,000 cells/ cmm		
Differential count	P ₆₀ , L ₃₅ , E ₅		
i. Platelet count	2 to 5 lakhs/cmm		
j. Life span	10 days		
8. Clot retraction time	Onset at 1 hour and Completion at 6 hours		
9. Reticulocyte count	0.5 to 1.5%		
10. ESR			
Males	0 to 20 mm/hr		
Females	0 to 30 mm/hr		
11. CRP	< 10 mg/L		
12. Complement			
C ₃	75 to 150 mg/dl		
C ₄	25 to 50 mg/dl		
13. Immunoglobulins			
IgA	100 to 500 mg/dl		
IgM	50 to 250 mg/dl		
IgG	800 to 1800 mg/dl		
IgE	< 0.025 mg/dl		
IgD	0 to 8 mg/dl		

Urine

Calcium	0 to 250 mg/day
Catecholamines	< 500 µg/day
Copper	25 to 100 mg/day
Cortisol	25 to 100 mg/day
Creatinine	
Males	1 to 2 gm/day
Females	0.5 to 1.5 gm/day
5 HIAA	< 9 mg/day
Hydroxy proline	25 to 75 mg/day
Metanephrine	< 0.9 mg/day

Stool

Normal weight	< 200 gm/day
Fat	< 7 gm/day
Stercobilinogen	40 to 280 mg/day

Sweat

Sodium	< 60 mEq/l
Chloride	< 70 mEq/l

Hormones

Growth hormone	< 8 ng/ml
Insulin	< 20 µU/ml
Thyroxine (T ₄)	5 to 12 µg/dl
Triiodothyronine (T ₃)	80 to 200 ng/dl
TSH	0.4 to 6.2 µU/ml
Parathormone	10 to 50 pg/ml
Prolactin	
Males	5 to 15 ng/ml
Females	5 to 25 ng/ml
Free testosterone	
Males	50 to 250 pg/ml
Females	1 to 5 pg/ml
Progesterone	
Males	< 0.5 ng/ml
Females	
Follicular phase	0.1 to 1.5 ng/ml
Luteal phase	2.5 to 28 ng/ml
1st trimester	9 to 47 ng/ml
3rd trimester	55 to 255 ng/ml
Post-menopausal	< 0.5 ng/ml
LH	
Males	0 to 9 IU/L
Females	
Follicular phase	1.4 to 11.5 IU/L
Luteal phase	0.1 to 16 IU/L
Midcycle	20 to 75 IU/L
Post-menopausal	8.5 to 46.5 IU/L
FSH	
Males	2.5 to 20 IU/L
Females	
Follicular phase	3 to 20 IU/L
Luteal phase	1.5 to 10 IU/L
Midcycle	10 to 23 IU/L
Post-menopausal	18 to 126 IU/L

Cortisol (morning)	8 to 25 µg/dl
Aldosterone	10 to 150 ng/l
ACTH (8 AM-supine, fasting)	< 60 pg/ml
β-hCG	
Nonpregnant	3 mIU/ml

Cerebrospinal Fluid

Glucose	40 to 70 mg/dl
---------	----------------

Total protein		20 to 50 mg/dl
WBC's	TC	< 5/µL
	DC	60 to 70%
	M	30 to 50%
	N	0%
Chloride		116 to 122 mmol/L
Pressure		50 to 180 mm water
Volume		150 ml

Index

A

- Abbreviated coma scale 428
- Abdomen 269
- Abdominal
 - reflexes 490
 - scan 792
- Abetalipoproteinaemia 552
- Abnormal responses 492
- Abnormalities of
 - gait 489
 - tendon reflexes 494
- Absent breath sounds 216
- Absolute reticulocyte count 345
- Abulia 428
- Accelerated hypertension 89
- Accessory nerve 474
- Achalasia cardia 286
- Acid-base balance 422
- Acidosis 424
- Acoustic neuroma 473
- Acquired
 - causes of late onset ataxia 556
 - hypothyroidism 622
- Actions of
 - calcitonin 628
 - insulin 648
 - parathormone 628
- Acute
 - alcohol hepatitis 771
 - central cervical spinal cord injury 572
 - complications of diabetes 661
 - coronary syndromes 179
 - diarrhoea 293
 - glomerulonephritis 407
 - interstitial nephritis 411
 - intoxication 772
 - kidney injury 411
 - lymphoblastic leukaemia 375
 - myeloid leukaemia 369
 - pancreatitis 334
 - pericarditis 112
 - poststreptococcal GN 408
 - rejection 51
 - renal failure 411
 - respiratory distress syndrome 261
 - thyroiditis 625
 - transverse myelitis 579
- Addison's disease 637
- Adipsic hypernatraemia 614
- Adrenal
 - crisis 640
 - glands 634
 - insufficiency 637, 681
- Advantages of MRI 801
- Aetiology of
 - aplastic anaemia 360
 - cancers 726
 - oedema 37
- Agnosia 437
- Airway obstruction 742
- Akinetic mutism 428
- Alcohol and
 - central nervous system 772
 - drug interactions 774
 - lymphatic system 774
 - malignancy 774
- Alcohol
 - dementia 772
 - withdrawal 775
- Alcoholic
 - cerebellar degeneration 772
 - cirrhosis 318
 - coma 772, 775
 - myopathy 773
- Algorithm for ABG analysis 426
- Alkalosis 425
- Allergic angiitis 718
- Allogeneic stem cell transplant 393
- Alopecia 758
- Ambiguous genitalia 643
- Amnesia 430
- Amoebic abscess 316
- Amyotrophic lateral sclerosis 547
- Anaemia 347
- Anaemia of chronic disease 354
- Anal cancer 727, 730, 731, 748
- Analysis of ECG 115
- Anatomical peculiarities 446, 456, 465
- Ancillary diagnostic supportive tests 537
- Angina pectoris 79, 80
- Anginal equivalent 79
- Angiography 790
- Ankylosing spondylitis 705
- Anomalous pulmonary venous connection 139
- Anorexia 728, 756
 - nervosa 75
- Anterior
 - lobe 606
 - spinal artery syndrome 569
- Anthropometric classification 14
- Anticancer drugs 747
- Antiemetics 756
- Antigen presenting cells 46
- Antihypertensive therapy 178
- Aortic
 - arch syndrome 719
 - regurgitation 156
 - root to right heart shunt 124
 - stenosis 154
- Aorto-pulmonary level shunt 124
- Aplastic anaemia 360
- Apnoea-hypopnoea index 232
- Approach to
 - acid-base disorders 425
 - coma 431
 - patient 431
- Apraxia 436
- Arrangement of
 - fibres 568
 - sensory fibres 503
- Arterial
 - blood gas analysis 225
 - occlusion 36
 - pulse 82
 - puncture 819
- Arteriovenous malformation 536
- Arthritis 696
- Arthritogenic bacteria in reactive arthritis 707
- Ascites 324
- Ascitic fluid aspiration 809
- Ascorbic acid 65
- Ataxia 557
 - telangiectasia 518, 553
- Ataxic disorders 550, 552-554

Atlanto-axial dislocation 588
 Atlanto-occipital synostosis 587
 Atrial septal defect 128
 Audiometric tests 470
 Austin-Flint murmur 158
 Autoantibodies in SLE 709
 Autoimmune
 disease 51, 638
 hepatitis 314
 Autologous BMT 392
 stem cell transplant 393
 Automated full blood analysis 347
 Automatic motor activities during sleep 440
 Autonomic
 nervous system 565
 neuropathy 565
 Autosomal
 dominant inheritance 43
 recessive
 inheritance 44
 late onset ataxia 556
 AV node 120
 Axial arthritis 696

B

Bacterial thyroiditis 625
 Bald tongue 12
 Ball's disease 741
 Barber's chair sign 507
 Barnett's classification 584
 Basal ganglia 477
 Basilar invagination 587
 Basophils 364
 Beau's line 25
 Becker's dystrophy 597
 Bed wetting 441
 Bedside cardiovascular reflex test 565
 Behçet's syndrome 720
 Bell's palsy 468
 Benign
 intracranial hypertension 540
 positional vertigo 472
 Berger's disease 409
 Beta cell tumour 681
 Bi-fascicular block 110
 Biliary
 cirrhosis 319
 obstruction 743
 Binocular visual loss 451
 Biotin 64
 Biphasic murmurs 104
 Biventricular hypertrophy 108
 Black nail 26
 Bladder
 cancer 727, 731, 732, 754
 innervation 583

Blood
 pressure 87, 88
 supply of spinal cord 569
 transfusion 362
 Bloody tap 807
 Blue nail 26
 B-lymphocytes 47
 Bone 699, 774
 Bone and joint tuberculosis 242
 Bone marrow
 aspiration 810
 transplantation 391
 Borders of lung 200
 Bowel sounds 282
 Brachytherapy 746
 Bradyarrhythmias 122
 Brain
 death 536
 metastasis 738
 Breast cancer 727, 730, 732, 748
 Breath sounds 216
 Broad complex tachycardia 121
 Bronchial asthma 227
 Bronchiectasis 236
 Bronchogenic carcinoma 258
 Bronchopulmonary segments 200
 Bronchoscopy 226
 Bruit 282
 Budd-Chiari syndrome 334
 Bulimia 75

C

Cachexia 728, 756
 Cadaver donor selection 338
 Calcium 68
 Caloric testing 471
 Canadian Heart Association grading of
 angina 79
 Cancer 724
 anorexia 728
 cervix 754
 Carcinoid tumours 302
 Cardiac
 abnormalities 127
 arrest 195
 causes 33
 cirrhosis 321
 failure 163
 malposition 124
 tamponade 195
 transplantation 197
 Cardinal rules of percussion 213
 Cardiogenic
 pulmonary oedema 166
 shock 39
 Cardiopulmonary resuscitation 196
 Cardiovascular
 infections 735
 system 77, 697, 774
 Cardioversion 197
 Catamenial pneumothorax 256
 Cataplexy 440
 Catatonia 429
 Cell biology of cancer 724
 Central
 core disease 599
 nervous system 699
 pontine myelinosis 773
 Centronuclear myopathy 599
 Cerebellar lesions 501
 Cerebellum 499
 Cerebral
 diplegia 578
 palsy 578
 tumours 541
 Cerebrospinal fluid 825
 Cerebrotendinous xanthomatosis 552
 Cerebrovascular
 disease 772
 disorders 518
 Cervical
 cancer 728
 spondylosis 573
 Cervicomedullary junction 580
 Cervix cancer 731, 732
 Cessation
 methods 778
 process 778
 Characteristics of
 anginal pain 79
 disease in old age 762
 smokers 776
 Charcot-Marie tooth disease 594
 Chemotherapy 746, 759
 Chest
 deformities 208
 film 782
 pain 33, 204
 X-ray 222
 Chimerism 44
 Cholestanolosis 552
 Chromium 70
 Chromosomal
 abnormalities 43
 disorders 127
 Chronic
 bronchitis 233
 GN 410
 hepatitis 311, 312
 inflammatory demyelinating
 polyneuropathy 593
 interstitial nephritis 411
 kidney disease 414

- lymphocytic
 - leukaemia 377
 - thyroiditis 626
 - myeloid leukaemia 373
 - obstructive pulmonary disease 233
 - pancreatitis 336
 - rejection 51
 - renal failure 414
 - thyroiditis 626
 - struma lymphomatosa 626
 - Churg-Strauss disease 718
 - Chylomicrons 684
 - Chylothorax 255
 - Chylous ascites 325
 - Circadian rhythm sleep disorders 441
 - Cirrhosis of liver 317
 - Cisternal puncture 808
 - Clinical classification of
 - diarrhoea 293
 - pulmonary hypertension 264
 - stroke 519
 - Clinical
 - consequences of infective endocarditis 161
 - manifestations of cerebellar dysfunction 500
 - Clonus 481
 - Closed mitral valvotomy 150
 - Clubbing 204
 - Coarctation of aorta 138
 - Cobalt 70
 - Cockayne syndrome 553
 - Cognitive scales 446
 - Collateral circulation 322
 - Colon cancer 748
 - Colorectal cancer 727, 729, 731
 - Colour of
 - hair 8
 - skin 24
 - Coma 428, 430
 - vigil 428
 - Common
 - chromosomal disorders 45
 - involuntary movements 486
 - mediastinal masses 260
 - organisms 250
 - sites of aneurysm 535
 - types of lung cancer 258
 - Complete transposition of great vessels 142
 - Complications of
 - cirrhosis 321
 - endoscopy 291
 - hypertension 179
 - insulin therapy 651
 - peptic ulcer disease 289
 - sternal puncture 811
 - therapy 756
 - Compressive myelopathy 579
 - Computed tomography 795
 - Congenital
 - abnormalities of coronary arteries 145
 - aortic stenosis 137
 - ataxias 551
 - complete heart block 144
 - heart diseases 123
 - Horner's 566
 - jaundice 307
 - muscular dystrophy 598
 - myopathies 599
 - TB 247
 - Congenitally corrected transposition of great vessels 142
 - Congestive
 - heart failure 682
 - states 284
 - Connective tissue disorders 695
 - Consciousness 428, 430
 - Constipation 756
 - Contents of cigarette smoke 776
 - Continuous
 - ambulatory peritoneal dialysis 418
 - murmurs 103
 - Contraindications
 - cardioversion 197
 - cytotoxic therapy 814
 - Contrast MRI 190
 - Control of arterial blood pressure 39
 - Copper 70
 - Coronary
 - arteriovenous fistula 145
 - artery 146
 - Cortical
 - sensations 507
 - venous thrombosis 531
 - Cough 201
 - Crack pot resonance 214
 - Cranial
 - arteritis 719
 - nerves 548
 - Craniopharyngioma 612
 - Craniovertebral junction anomalies 586
 - Creatinine clearance 401
 - Crest syndrome 715
 - Creutzfeldt-Jakob disease 563
 - Crigler-Najjar syndrome 307
 - Crohn's disease 298
 - Cryptic miliary tuberculosis 241
 - Cryptogenic cirrhosis 319
 - CT
 - abdomen 800
 - angiography 795
 - brain 795
 - chest 795
 - coronary angiography 799
 - scan 225, 795
 - Curative radiation therapy 746
 - Cushing's syndrome 635, 737
 - Cutaneous afferent innervation 502
 - Cyanosis 81
 - Cytokine antagonist 704
- ## D
- De Quervain's thyroiditis 625
 - Deafness 472
 - Decreased body hair distribution 8
 - Deep tendon reflexes 493
 - Dejerine-Sottas disease 595
 - Delirium 429
 - Dementia 429
 - Development of infective endocarditis 161
 - Devic's disease 579
 - Dextrocardia 127
 - Diabetes
 - insipidus 613
 - mellitus 645
 - Diabetic
 - foot 674
 - hand syndrome 669
 - nephropathy 669, 675
 - neuropathy 671
 - retinopathy 667
 - Diagnosis of
 - gestational DM 676
 - rheumatic fever 146
 - Diagnostic
 - approach to dysphagia 285
 - criteria for CIDP 594
 - Dialysis 417
 - Diarrhoea 292
 - Diastolic murmurs 103
 - Dipsogenic DI 614
 - Dipstick testing 396
 - Disadvantages of MRI 803
 - Disorders of
 - immunoglobulins 49
 - neurohypophysis 613
 - parathyroid gland 628, 632
 - white cells 363
 - Dispersed immune cells 46
 - Distributive shock 39
 - Disturbances of hydrogen ion homeostasis 424
 - Drug 600, 680
 - fever 29
 - induced lupus 711
 - Dry tap 806, 809, 811
 - Dubin-Johnson syndrome 308
 - Duchenne dystrophy 597

Dural sinus thrombosis 531
 Dysarthria 443
 Dysphagia 284
 Dyspnoea 78, 203
 Dysomnias 439
 Dystrophia myotonica 599

E

Eaton-Lambert syndrome 602
 Ebstein's anomaly 140
 ECG features of
 COPD 115
 hypothermia 115
 ECG in
 acute pulmonary embolism 114
 coronary artery disease 111
 electrolyte imbalance 113
 various arrhythmias 115
 Echocardiography 794
 Ectopic
 acromegaly 737
 ACTH syndrome 737
 Effect of
 alcohol on liver 770
 diabetes on pregnancy 676
 sleep deprivation 439
 Eighth cranial nerve 469
 Eisenmenger syndrome 133
 Ejection clicks 100
 Electrical axis 106
 Electrocardiogram 106
 Eleventh cranial nerve 474
 Embryology 133
 Emphysema 233
 Empty sella syndrome 612
 Empyema thoracis 254
 Encephalitis 562
 Endobronchial and laryngeal
 tuberculosis 242
 Endocrine
 causes of hyperparathyroidism 632
 infections 735
 metabolic disorders 605
 syndromes 735
 Endometrial cancer 754
 Endoscopy 290
 Endotracheal intubation 820
 End-stage renal disease 417
 Energy yielding macronutrients 54
 Eosinophils 47, 363
 Epidural
 abscess 572
 haemorrhage and haematomyelia
 573
 Epilepsy 511
 in pregnant women 516
 Epileptic seizures 511
 Essential
 neurological signs 537
 thrombocythaemia 366
 Ethanol 681
 Evaluation of nephrotic syndrome 407
 Examination of
 auditory function 469
 cranial nerves 446
 higher mental functions 430
 III, IV and VI cranial nerves 456
 motor function 466
 neck 206
 veins 90
 reflexes 467
 respiratory system 207
 secretory functions 467
 sensory functions 466
 skin 4
 speech and language 444
 Examples of monoclonal gammopathies
 382
 Excess
 carotenes 60
 hair 8
 External
 features of cardiac disease 92
 manifestations of respiratory diseases
 207
 Extra-articular features 708
 Extracardiac obstructive shock 39
 Extrapyrarnidal system 477
 Extravasation 756
 Extreme anaemia 729
 Eye signs in parkinsonism 544
 Ezetimibe 687

F

Facial nerve 465
 involvement in leprosy 468
 Facio-scapulo-humeral dystrophy 598
 Factitious hypoglycaemia 680
 Factors
 determining rate of heat production
 27
 identifying high risk patients 144
 increasing sickling 357
 influencing
 insulin absorption 651
 prognosis 172
 precipitating asthma 228
 predisposing to
 bleeding 322
 bronchiectasis 236
 Falciparum malaria 682

Familial
 benign hypercalcaemia 631
 hypocalcaemic hypercalcaemia 631
 Fascicular blocks 109
 Fasting hypoglycaemia 680
 Fatty liver 771
 Febrile convulsions 27
 Fed hypoglycaemias 683
 Fever 27, 729
 Fever with
 exanthems 27
 relative bradycardia 27
 Fibrates 688
 Fibrosis 220
 Fifth cranial nerve 463
 Fingers 19, 20
 First
 cranial nerve 446
 heart sound 97
 Fissured tongue 11
 Fluid and electrolyte imbalance 419
 Fluorine 69
 Foetal alcohol syndrome 773
 Folic acid 65
 Foramen magnum 580
 Forward and backward heart failure 164
 Fourth heart sound 99
 Friction rub 282
 Friedreich's ataxia 553
 Frontal lobe lesions 444
 Fulminant hepatic failure 326
 Functional murmurs 105
 Functions of
 occipital lobe 445
 parietal lobe 444
 sensory cortex 507
 skin 23
 sleep 439
 temporal lobe 445
 vitamin
 A 59
 C 65
 Fundamentals in genetics 42
 Fundus in cardiology 92

G

Gallbladder 276
 Gas diffusion capacity 225
 Gastric
 cancer 729, 731, 748
 carcinoma 726
 ulcer and malignancy 304
 Gastrointestinal
 bleeding 291
 system 284, 697
 tract infection 734

- Gastro-oesophageal reflux disease 287
 General principles of auscultation 215
 Genes 724
 Genetic
 classification 546
 disorders 127
 Genitourinary
 system 774
 tuberculosis 242
 Genomic imprinting 45
 Geographic tongue 11
 Geriatric medicine 761
 GI toxicity 757
 Giant cell arteritis 719
 Giants of geriatric medicine 764
 Gilbert's syndrome 308
 Glasgow coma scale 428
 Glomerular injury 729
 Glomerulonephritis 407
 Glomerulopathies 404
 Glossopharyngeal nerves 473
 Glucose homeostasis 679
 Goals of insulin therapy 647
 Goodpasture's syndrome 408
 Grading of
 ascites 281
 dyspnoea 203
 Granulomatosis 718
 Granulomatous thyroiditis 625
 Graphaesthesia 508
 Guillain-Barré syndrome 592
 Gynaecomastia 644, 737
- H**
- Haematemesia 291
 Haematochezia 291
 Haematologic
 syndromes 737
 values 823
 Haematological
 disorders 284
 malignancies 368
 Haematology 341, 774
 Haematopoiesis 342
 Haematopoietic
 growth factors 342
 stem cell 342
 differentiation 342
 transplantation 393
 Haemochromatosis 331
 Haemodialysis 418
 Haemofiltration 418
 Haemolytic
 anaemia 355
 uremic syndrome 758
- Haemoptysis 202, 742
 Haemorrhagic cystitis 757
 Haemothorax 255
 Hairy
 cell leukaemia 378
 tongue 11
 Handedness 435
 Hands 19
 Hashimoto's thyroiditis 626
 Head and neck cancer 727, 730, 731, 754
 Headache 537, 538
 Heart
 block 122
 murmurs 101
 sounds 97
 Heat loss from body 27
 Heel pad thickness 22
Helicobacter pylori 287
 Hemiblocks 109
 Henoch-Schönlein purpura 409
 Hepatic
 cirrhosis 771
 coma 327
 encephalopathy 327
 failure 681
 segments 304
 Hepatocellular carcinoma 329, 727, 730, 731
 Hepatoma 329
 Hepatopulmonary syndrome 329
 Hepatorenal syndrome 328
 Hereditary
 ataxia 550
 sensory motor neuropathy 594
 spherocytosis 356
 High
 arched palate 9
 CSF protein 808
 density lipoprotein 684
 Highly toxic 703
 Hirsutism 644
 Histocompatibility antigens 51
 HIV 247
 associated nephropathy 405
 Hodgkin's disease 379
 Holandric inheritance 44
 Holiday heart syndrome 774
 Hormonal response to hypoglycaemia 679
 Hormones 824
 Horner's syndrome 566
 Human
 antibody infusion reactions 757
 insulins 648
 Hydatid thrill 282
 Hydrogen ion homeostasis 422
 Hyperacute rejection 51
 Hypercalcaemia 113, 628, 735
 in malignancy 631
 Hypercalcaemic crisis 631
 Hyperkalaemia 67, 113, 422
 Hyperlipoproteinaemias 683
 Hypermagnesaemia 113
 Hypernatraemia 67, 420
 Hyperosmolar coma 665
 Hyperpituitarism 608
 Hyperprolactinaemia 610
 Hyperpyrexia 30
 Hypersecretory disorders of anterior
 pituitary 608
 Hypertensive
 emergency 89
 states 89
 urgency 89
 Hyperthyroidism 617
 Hypertonia 480
 Hypertrichosis 8
 Hypertrophic
 obstructive cardiomyopathy 191
 osteoarthritis 729
 Hypervitaminosis
 C 66
 D 62
 Hypocalcaemia 113
 Hypocalcaemic disorder 632
 Hypoglossal nerve 475
 Hypoglycaemia in adults 679
 Hypokalaemia 67, 113, 421
 Hypomagnesaemia 113
 Hyponatraemia 66, 420, 736
 Hypophosphataemia 68
 Hypopituitarism 606
 Hypothalamus and pituitary gland 606
 Hypothermic coma 624
 Hypothyroidism 621
 Hypotonia 481
- I**
- Idiopathic
 dilatation of pulmonary artery 145
 haemochromatosis 333
 late onset ataxia 556
 Imaging modalities in internal medicine 781
 Immune
 system and basis of immunity 46
 thrombocytopenic purpura 387
 Immunodeficiency states 49
 Immunoglobulins 49
 Immunopathology 382
 Immunosuppression 339
 Immunosuppressive therapy in renal
 transplantation 419

- Impaired fertility 758
 Importance of auscultation 216
 Increased intracranial pressure 738
 Indications for
 DC shock 197
 permanent pacemakers 123
 pleural aspiration 806
 sleep study 232
 therapeutic aspiration 806
 urgent dialysis 414
 Indications of tracheostomy 819
 Infections in cancer patients 733
 Infective endocarditis 161
 Inflammatory
 bowel disease 298
 muscle disease 600
 Innocent murmurs 105
 Inorganic nutrients 66
 Insomnia 440
 Inspection of
 eyes 456
 optic nerve head and fundus 451
 Inspiratory tracheal descent 211
 Insulin
 analogues 648
 autoantibodies 682
 delivery systems 650
 receptor autoantibodies 682
 regimens 650
 therapy 647
 Insulinomas 681
 Insulinitis 647
 Intermediate density lipoprotein 684
 Intermittent peritoneal dialysis 418
 International classification of sleep disorders 439
 Internuclear lesions 460
 Interstitial
 lung disease 257
 pneumonitis 757
 Intestinal obstruction 742
 Intracerebral
 haemorrhage 532
 leucocytostasis 741
 Intravenous urography pyelography 790
 Introduction to internal medicine 1
 Inverted reflexes 498
 Involuntary movements 486
 Iodine 69
 Iron 68
 deficiency 69, 349
 anaemia 348
 excess 69
 metabolism 348
 Ironed out tongue 12
 Irritable bowel syndrome 301
 Ischaemic colitis 302
 Isletitis 647
 Isolated systolic hypertension 88, 172
 IVC obstruction 274
- J**
- Jaundice 306
 Jet-Lag syndrome 441
 Jones criteria 146
 Jugular venous
 pressure 90
 pulse 91
- K**
- Kawasaki disease 720
 Kidney 276
 biopsy 812
 Klippel-Feil anomaly 587
 Koilonychia 24
 Korotkoff sounds 87
- L**
- Labile hypertension 89
 Laboratory reference values 823
 Laceration 572
 Lactic acidosis 666
 Lacunar
 infarction 530
 syndromes 530
 Large veins and arteries 795
 Late effects of cancer therapy 758
 Leflunomide 703
 Left
 atrial enlargement 107
 bundle branch block 109
 sided effusions 255
 ventricular hypertrophy 107
 Lesions of
 occipital lobe 445
 temporal lobe 445
 Vth cranial nerve 465
 Leukaemias 369
 Levine and Freeman's grading of murmurs 101
 Lhermitte's sign 507
 Limb girdle muscular dystrophy 597
 Limited joint mobility 669
 Lindsay nail 25
 Linear scleroderma 715
 Lipoproteins 684
 Liver 275
 abscess 315
 biopsy 811
 needles 811
 function tests 304
 transplantation 337
 Lobar functions 444
 Localisation of
 cerebellar lesions 501
 spinal cord lesions 580
 Locked-in syndrome 429
 Long-term complications of diabetes 667
 Loss of secondary sexual character 8
 Low
 density lipoprotein 684
 set ears 9
 Lower
 motor neurons 477
 retrosternal pain 204
 Lumbar
 canal stenosis 574
 disc prolapse 576
 puncture 807
 needle 807
 Luminal phase 295
 Lung
 abscess 249
 cancer 727, 730, 732, 754
 function tests 221
 transplantation 268
 Lymph nodes 697
 Lymphocytes 363
 Lymphocytic thyroiditis 626
 Lymphoid malignancies 368
 Lymphoma 379, 381
- M**
- Macrocytosis 351
 Macrophages 47
 Madras motor neuron disease 548
 Magnesium 69, 633
 deficiency 633
 Magnetic resonance imaging 800
 Maintenance of central venous cannulation 817
 Major sites of collaterals 322
 Malabsorption 295
 Male osteoporosis 692
 Malignant
 ascites 742
 effusions 254, 741
 hypertension 89
 melanoma 755
 pericardial effusion 741
 pleural effusion 742
 tumours of thyroid 628
 ulcer 289
 Management of
 acute severe asthma 232
 ARF 414

- asthma 231
 - bronchial asthma 229
 - chronic hepatitis
 - B 312
 - C 313
 - diabetic neuropathies 673
 - DVT 268
 - hypertensive crisis 179
 - nocturnal asthma 232
 - pyogenic abscess 316
 - tuberculosis 243
 - UTI 403
 - Management protocol 745
 - Manganese 70
 - Manipulation of blood products 362
 - Marchiafava-Bignami syndrome 772
 - Marfan's syndrome 15
 - Marrow aspiration and infusion 392
 - Mast cell series 47
 - Maximum normal oral temperature 27
 - Measurement of chest expansion 211
 - Mechanism of
 - closure of defect 130
 - degeneration 573
 - diarrhoea 293
 - pleural fluid formation 251
 - blood vessel damage 716
 - production of headache 538
 - Mediastinal mass 260
 - Medullary carcinoma 628
 - Megaloblastic anaemia 351
 - Melaena 291
 - Meniere's disease 473
 - Meningeal carcinomatosis 738
 - Meningitis 560
 - Metabolic
 - disorders 552
 - liver disease 330
 - syndromes 729
 - Metabolism of
 - alcohol 770
 - bilirubin 306
 - Metastatic cancer 743
 - Methods of
 - collection of urine specimens 396
 - testing coordination 484
 - Methotrexate 702
 - Microalbuminuria 400
 - Mid-systolic clicks 100
 - Migration of lymphocytes 46
 - Miliary tuberculosis 241
 - Mitochondrial
 - disorders 45
 - encephalomyopathies 552
 - Mitral
 - regurgitation 151
 - stenosis 147
 - valve prolapse syndrome 153
 - Mixed connective tissue disease 712
 - MND with
 - dementia 549
 - parkinsonism 549
 - Modification of chronic therapy 678
 - Modified Osserman scale 601
 - Monoarthritis 696
 - Monocular visual loss 451
 - Monocytes 364
 - Monofilament test 672
 - Monomelic amyotrophy 548
 - Morphoea 715
 - Mosaicism 44
 - Most common causes of paraplegia 582
 - Motor
 - dysphagia 285
 - neuron disease 546
 - unit 477
 - Movement disorders 543
 - Movement of
 - chest 209
 - spine 567
 - MRI scan 225
 - Mucinous ascites 325
 - Mucocutaneous lymph node syndrome 720
 - Mucosal phase 295
 - Multiple
 - level shunts 124
 - myeloma 382
 - sclerosis 557
 - Muscle 697
 - sensitivity 507
 - wasting in
 - lower limbs 479
 - upper limbs 478
 - Muscular dystrophies 596
 - Myasthenia gravis 601
 - Myasthenic
 - crisis 601
 - syndrome 602
 - Myelodysplastic syndromes 378
 - Myelofibrosis 367
 - Myelogram appearance 583
 - Myelophthisic anaemia 368
 - Myeloproliferative disorders 365
 - Myocardial
 - infarction 182
 - injury 111
 - ischaemia 111
 - necrosis 111
 - Myocarditis 190
 - Myopathy 600
 - Myotonia 482
 - congenita 600
 - Myxoedema coma 624, 625
- ## N
- Nails in clinical medicine 24
 - Narcolepsy 440
 - Natural killer cells 47
 - Nature of marrow stem cell 342
 - Nausea and vomiting 728, 756
 - Needle 808, 810
 - Negative phenomena 502
 - Nemaline myopathy 599
 - Neonatal
 - Graves' disease 621
 - hyperthyroidism 621
 - Neoplasia 283
 - Neoplastic disease of central nervous system 541
 - Nephritic syndrome 404
 - Nephrogenic DI 614
 - Nephrology 395
 - Nephrotic syndrome 405
 - Nervous system 427
 - Neuroanatomy of sleep 438
 - Neurocutaneous syndromes 517
 - Neurofibromatosis 517
 - Neurogenic claudication 36
 - Neurohypophysis 606
 - Neurologic syndromes 738
 - Neuromuscular system 477
 - Neuromyelitis optica 579
 - Neutrophil 363
 - polymorphs 47
 - New York Heart Association 78
 - Niacin 63
 - excess 64
 - Nickel 70
 - Nicotinamide 63
 - Nicotinic acid 63, 687
 - Ninth and tenth cranial nerves 473
 - Non B-cell tumour 681
 - Non-ACTH-dependent 635
 - Non-alcoholic fatty liver disease 317
 - Non-articular manifestations of
 - rheumatoid arthritis 697
 - Non-compressive myelopathy 571
 - Non-energy yielding carbohydrates 54
 - Non-Hodgkin's lymphoma 380
 - Non-infective endocarditis 163
 - Non-islet cell tumour hypoglycaemia 737
 - Non-motor 544
 - Non-organ specific disorders 52
 - Non-pharmacologic measures 166
 - Nonsteroidal anti-inflammatory drugs 701
 - Normal
 - blood pressure 88
 - chromosome number and structure 42

reference values in haematology 345
 temperature regulation in body 26
 Nuclei of cerebellum 499
 Nucleus 463
 Numerical chromosome aberrations 43
 Nutrients 54
 Nutrition 53, 478
 Nutritional
 deficiency syndrome 773
 disorders 55
 Nystagmus 461

O

O' Sullivan-Mahan criteria 676
 Obesity 18, 72
 Obstructive
 diseases 227
 sleep apnoea-hypopnoea syndrome 232
 Occipitalisation of atlas 587
 Ocular
 manifestations 668
 motility 433
 movements 459
 Oculopharyngeal dystrophy 598
 Oesophageal cancer 726, 729, 731, 748
 Oesophagus 773
 Olfactory nerve 446
 Oligemic shock 39
 Oncologic emergencies 738
 Oncology 723
 Onset and course of symptoms 298
 Open mitral valvotomy/commissurotomy 150
 Opening snap (OS) 100
 Optic nerve 447, 451
 Orbit and eye 794
 Organ specific disorders 51
 Orthopnoea 78
 Orthostatic hypotension 88
 Osmotic diarrhoea 293
 Osteoarthritis 705
 Osteomalacia 61, 689
 Osteoporosis 690
 Ovarian cancer 728, 731, 732, 754

P

Paget's disease 692
 Pain 32, 728, 755
 due to disorders of GIT 34
 insensitive structures 538
 sensitive structures 538
 Painful hepatomegaly 283
 Painless thyroiditis 626
 Palliative radiation therapy 746
 Palpation of
 gallbladder 277
 kidneys 278
 liver 277
 spleen 277
 urinary bladder 279
 Pancoast syndrome 204
 Pancreatic cancer 727, 730, 731
 Pancytopenia 360
 Paradoxical hypertension 89
 Paramyotonia congenita 600
 Paraneoplastic syndromes 735
 Paraplegia 578
 Paraplegia in
 extension 582
 flexion 582
 Parapneumonic effusion 253
 Parasomnias 439, 440
 Parasternal impulse 95
 Parietal lobe lesions 445
 Parkinson's disease 543
 Parkinsonism plus syndromes 545
 Paroxysmal
 AV nodal tachycardia 120
 hypertension 89
 nocturnal dyspnoea 78
 symptoms 558
 Passing nasogastric tube 817
 Passive smoking 777
 Patent ductus arteriosus 131
 Pathological
 causes of nutritional disorders 55
 Q-wave 115
 stages in development of pneumonia 247
 Pathophysiologic classification of proteinuria 399
 Pathophysiology of
 DKA 661
 oedema 37
 stroke 519
 Patterns of fever 27
 Pavor nocturnus 440
 Pellagra 64
 Peptic ulcer 287, 288
 disease 287
 Percussion of
 cyst 282
 lung fields 213
 Percussion on
 left side 215
 right side 214
 Percutaneous
 balloon valvuloplasty 150
 central venous cannulation 815
 Performance status 733
 Pericardial
 knock 100
 rub 100
 Pericardiocentesis 808
 Pericarditis 194
 Perilymphatic leaks 472
 Periodic Cushing's syndrome 635
 Peripheral
 blood stem cell transplantation 394
 film morphology 346
 labyrinthine disorders 472
 neuropathy 557, 589, 773
 vascular pain 36
 Persistent flaccid paraplegia in UMN lesions 582
 Pheochromocytoma 640
 Pharmacologic therapy 167
 Pharmacology of cigarette smoke 776
 Phosphorus 68
 Photodynamic therapy 746
 Physiological variation of temperature 27
 Pituitary
 hyperplasia 612
 tumours 611
 Plain abdominal film 782
 Plain X-ray skull 786
 Plantar reflex 492
 Plasma cell dyscrasias 381
 Platybasia 587
 Platypnoea 79
 Pleural aspiration and
 biopsy 806
 percutaneous pleural biopsy 226
 Pleural
 aspiration needle 806
 biopsy 806
 border 200
 effusion 251
 fluid analysis 252
 pain 204
 Plummer nail 25
 Pneumonia 247
 Pneumothorax 255
 Polyarteritis nodosa 716
 Polyarthritis 696
 Polycystic
 kidney disease 411
 liver disease 315
 Polycythaemia vera 365
 Polygenic inheritance 85
 Polymorphic VT 121
 Polymyositis 595
 Poor prognostic
 factors 376, 547, 593
 indicators 327, 335
 Portal hypertension 321

- Position sense 505
 Positive phenomena 502
 Positron emission tomography 792
 Posterior spinal artery syndrome 570
 Posterolateral sclerosis of spinal cord 586
 Postinfectious GN 408
 Postnecrotic cirrhosis 319
 Postprimary pulmonary tuberculosis 242
 Postulated mechanisms for ageing 762
 Potassium 67, 421
 Practical classification of anaemia 347
 Precautions after seizure attack 515
 Precipitating factors for epilepsy 511
 Precocious puberty in
 females 643
 males 644
 Predisposing
 conditions 365
 factors 247, 249, 254, 258, 561, 574, 665
 Predominant
 LMN involvement 547
 UMN involvement 548
 Pregestation diabetes mellitus 677
 Pregnancy 381
 Pregnancy and
 alcohol 773
 diabetes 675
 SLE 710
 Preleukaemic syndromes 378
 Premature sexual developmental disorders 643
 Preparation of patient 392
 Proliferative retinopathy 667
 Prevention of
 caries 69
 hepatitis 314
 Primary
 cardiomyopathies 192
 hyperlipoproteinaemias resulting 684
 hyperparathyroidism 629
 immunodeficiency disorders 49
 lateral sclerosis 548
 lymphoid organs 46
 myelosclerosis 367
 skin lesions 23
 thrombocytosis 366
 tuberculosis 240
 Primitive reflexes 498
 Principles of
 cancer therapy 745
 chemotherapy 746
 management of geriatric problems 767
 Progressive
 bulbar palsy 547
 medullo-spinal compressions 588
 muscular atrophy 547
 systemic sclerosis 712
 Proliferative retinopathy 668
 Prolonged QTC interval 114
 Prophylaxis for UTI 404
 Proprioceptive sensations 505
 Prostate cancer 731, 732, 754
 Prosthetic sounds 101
 Proteins 55
 Proteinuria 398
 Pruritus 729, 756
 Pseudo coma 429
 Pseudobulbar palsy 548
 Pseudohypertension 89
 Pseudohypoparathyroidism 633
 Pseudopseudohypoparathyroidism 633
 Pseudoseizures 517
 Pseudo-von Grafe's sign 456
 Psoriatic arthritis 708
 Pulmonary
 angiography 226
 artery 146
 hypertension 264
 regurgitation 160
 stenosis 135, 137, 160
 thromboembolism 266
 Pulsatile liver 283
 Pulse
 character 83
 rate 82
 volume 83
 Pupillary reflexes 458
 Pure vitamin E deficiency 552
 Pyrexia of unknown origin 30
 Pyridoxine 64
 excess 64
- Q**
- Qualitative platelet disorders 386
 Quantitative platelet disorders 386
 Queckenstedt's test 808
 Quinidine effect 114
- R**
- Radiation therapy 745, 759
 Radio-femoral delay 87
 Radiofrequency ablation 118
 Radioimmunotherapy 746
 Radioisotope scanning 791
 Radionuclide therapy 746
 Ramsay Hunt syndrome 557
 Rapidly progressive GN 409
 Rectal cancer 748
 Recurrent
 pneumoniae 248
 transitory attacks 588
 Red nail 26
 Reducing substances in urine 401
 Reflexes 490
 Refsum's disease 595
 Regions of abdomen 273
 Reid index 235
 Reiter's disease 707
 Released reflexes 498
 Renal and ureteral infections 735
 Renal
 cell carcinoma 727, 730, 732, 754
 failure 682
 pain 36
 system 697
 transplantation 418
 Respiration 432
 Respiratory
 causes 33
 diseases 227
 system 199, 697, 774
 Response to treatment 747
 Restrictive
 cardiomyopathy 191
 diseases 227
 Reticulocyte index 345
 Retinol 59
 Rheumatic fever 146
 Rheumatoid arthritis 696
 Riboflavin 63
 Rickets 60
 Riedel's
 struma 627
 thyroiditis 627
 Right and left sided heart failure 164
 Right
 atrial enlargement 107
 bundle branch block 108
 sided effusions 255
 ventricular
 hypertrophy 108
 infarction 187
 Risk factors for
 alcoholic liver disease 770
 deep vein thrombosis 266
 diabetic retinopathy 668
 stroke 519
 type 2 diabetes mellitus 646
 Romberg's test for position sense 506
 Rotor syndrome 308
 Rubeosis iridis 668
 Rule of
 3 504
 hundreds for tachycardias 115

- S**
- Sarcomas 755
 - Saturday night palsy 773
 - Scale for grading pain 755
 - Schober test 706
 - Scurvy 65
 - Second
 - cranial nerve 447
 - heart sound 98
 - malignancy 758
 - wind angina 80
 - Secondary
 - adrenal insufficiency 638
 - cardiomyopathies 192
 - hyperaldosteronism 634
 - hyperlipoproteinaemias 686
 - hyperparathyroidism 632
 - immunodeficiencies 50
 - lymphoid organs 46
 - Secretory
 - diarrhoea 293
 - tumours 611
 - Seizures 741
 - Selection of donor 392
 - Selenium 70
 - Semiconsciousness 428
 - Sensory
 - dermatomes 504
 - dissociation 508
 - pathways 502
 - system 502
 - Sepsis 682
 - Seronegative arthritis 705
 - Serum
 - biochemistry 823
 - enzymes 304, 823
 - Setting up drip 813
 - Seventh cranial nerve 465
 - Severity of haemoptysis 202
 - Sexual disorders 643
 - Shift-work sleep disorders 441
 - Shock 39, 95
 - Shortened QTC interval 114
 - Sick sinus syndrome 122
 - Sickle cell disease 357
 - Sideropenic anaemia 354
 - Signs and symptoms of hypoglycaemia 680
 - Signs of
 - liver cell failure 272
 - pyramidal tract lesion 476
 - wide pulse pressure 156
 - Silent thyroiditis 626
 - Simple anaemia 354
 - Single gene
 - disorders 43, 127
 - mutations 684
 - Site of lesion 741
 - Skeletal defects 15
 - Skin 699, 774
 - cancer 728
 - in clinical medicine 22
 - Sleep 437
 - apnoea syndromes 440
 - bruxism 441
 - centre 438
 - disorders
 - associated with medical or psychiatric disorders 439
 - with neurologic disorders 441
 - enuresis 441
 - terrors 440
 - Slow virus disease 562
 - Small bowel 773
 - cancer 727, 729, 731
 - Small muscle wasting of hand 479
 - Smoking 775
 - Smoking and
 - body weight 777
 - cardiovascular disease 776
 - depression 777
 - drugs 777
 - gastrointestinal disorders 777
 - pregnancy 777
 - respiratory disease 777
 - Smoking index 777
 - Sodium 66, 419
 - Somnambulism 440
 - Speech areas 442
 - Spinal
 - cord 568
 - compression 741
 - disorders 570
 - enlargements 568
 - tumours 541
 - muscular atrophy 550
 - syphilis 572
 - Spine 567
 - Spinomotor system 475
 - Spirometry 221
 - Spleen 276
 - Splenomegaly 283
 - Spontaneous
 - bacterial peritonitis 324
 - pneumothorax 255
 - Spontaneously resolving hyperthyroidism 626
 - Sputum 201
 - examination 220
 - Squint 459
 - S-T segment
 - depression 110
 - elevation 110
 - Stages in diabetic nephropathy 675
 - Stages of
 - care in diabetic pregnancy before conception 677
 - hair follicle growth 7
 - State of nutrition 17
 - Statistical risk disease 646
 - Status epilepticus 515
 - Steatosis 316
 - Stem cell diseases 342
 - Stereognosis 508
 - Stomach 773
 - Stool 824
 - Storage disorders 283, 284
 - Strabismus 459
 - Stress ulcer 288
 - Stroke 518
 - Structural aberration of chromosome 43
 - Stupor 428
 - Sturge-Weber syndrome 518
 - Subacute
 - combined degeneration 586
 - sclerosing pan encephalitis 562
 - thyroiditis 625
 - Subarachnoid haemorrhage 534
 - Sub-clavian Steal syndrome 530
 - Sub-clinical hypothyroidism 624
 - Substance abuse 769
 - Success rate 339
 - Superior vena caval obstruction 738
 - Suppurative thyroiditis 625
 - Surface marking of organs 275
 - Surface of abdomen 274
 - Surgery 745
 - Sustained monomorphic VT 121
 - Sweat 824
 - Swinging light test 451
 - Symptom control in severe cancer 755
 - Symptoms of UTI 402
 - Syncope 80
 - Syndrome of inappropriate antidiuretic hormone secretion 615
 - Syndromes associated with phaeochromocytoma 641
 - Syndromes with
 - ASD 128
 - PDA 131
 - VSD 130
 - Syphilis 572
 - Syringobulbia 585
 - Syringomyelia 583

- Systemic
 hypertension 171
 lupus erythematosus 708
- Systolic murmurs 101
- Systolico-diastolic murmur 105
- T**
- Tabes dorsalis 572
- Tachyarrhythmias 115
- Takayasu's arteritis 719
- Target organ resistance 633
- TB meningitis 242
- Technique of auscultation 215
- Teletherapy 746
- Temporal arteritis 719
- Tenderness over chest wall 212
- Terminology of skin lesions 23
- Terry nail 26
- Tertiary hyperparathyroidism 632
- Test of vestibular function 471
- Testicular cancer 728, 731, 732, 754
- Testing of
 sternocleidomastoid muscle 474
 trapezius muscle 474
 visual
 acuity 448
 fields 448
- Testing sense of smell 446
- Tests for nerve root compression 576
- Tests of
 biosynthetic function 304
 cholestasis 305
- Tetralogy of Fallot 133, 137
- Thalassaemia 358
- Theories of clubbing 205
- Therapeutic
 application of stem cells 342
 oesophagogastro-duodenoscopy 291
- Therapy of selected cancers 748
- Thiamine 63
- Thick-walled cavity 220
- Thin-walled cavity 220
- Third heart sound 99
- Thomson's disease 600
- Thrills 95
- Thrombocytopenia 388
- Thrombocytosis 366
- Thrombotic thrombocytopenic purpura 388
- Thunderclap headache 535
- Thymoma 601
- Thyroid
 disorders 616
 gland 616
 scan 794
 storm 620
- Thyroiditis 625
- Thyrotoxic crisis 620
- Timed vibration sense 507
- T-lymphocytes 47
- TNM classification 732
- To-and-fro murmurs 104
- Tobacco alcohol amblyopia 773
- Tongue 10
- Tongue in neurology 12
- Toxicity of radiation therapy 746
- Toxins 283
- Tracheal tug-Olliver's sign 210
- Tracheostomy 819
 tubes 820
- Transient hypertension 89
- Transport phase 295
- Traumatic
 lesions of spinal cord 571
 pneumothorax 256
- Treatable cerebellar lesions 501
- Treatment for diabetic erectile dysfunction 673
- Treatment of
 acute heart failure 165
 GBS 593
 reactive hypoglycemia 683
 SAH 536
- Treatment regimens in special situations 244
- Trephine biopsy 811
- Trepopnoea 79
- Tricuspid
 atresia 143
 regurgitation 159
 stenosis 158
- Tri-fascicular block 110
- Trigeminal nerve 463
- Triggering factors 696
- Trinucleotide repeat 45
- Tropical pancreatitis 337
- Truncus arteriosus 143
- Tuberculosis 240, 247, 572
- Tuberculosis of abdomen 295
- Tuberous sclerosis 517
- Tubulointerstitial disease 410
 of kidney 410
- Tumour
 antigens 52
 lysis syndrome 757
 suppressor genes and familial cancers 724
- Twelfth cranial nerve 475
- Two-point discrimination 507
- Type
 I hypersensitivity 50
 II hypersensitivity 50
 III hypersensitivity 50
 IV hypersensitivity 51
- Types of
 alopecia 7
 AVM 536
 bone marrow transplantation 392
 bronchial breathing 216
 endotracheal tubes 820
 fibrosis 220
 haemoptysis 202
 muscle wasting 478
 obesity 72
 smoking 778
 tracheostomy 819
 wheeze 217
- U**
- Ultrasound 792
 scan 225
- UMN fibres corticobulbar tracts 548
- Unresolved pneumoniae 248
- Unusual features in GBS 593
- Upper
 gastrointestinal endoscopy 290
 motor neuron lesions 460
 retrosternal pain 204
- Uraemia 113
- Urethral catheterisation 818
- Urinary
 obstruction 743
 tract infection 401
 tract infection 402
- Urine 824
 analysis 396
- V**
- Vaccination of cancer patients 735
- Vagus nerves 473
- Valve replacement 151
- Valvular
 clicks 100
 heart disease 147
- Variant forms of myeloma 382
- Variants of
 motor neuron disease 548
 rheumatoid arthritis 699
- Variceal bleeding 322
- Various sensory lesions 508

- Vascular
 clicks 100
 syndromes of spinal cord 569
- Vasculitis syndromes 715
- Ventilation-perfusion imaging 225
- Ventricular
 level shunt 124
 septal defect 129
- Vertigo 471
- Very low density lipoprotein 684
- Vestibular neuronitis 473
- Vestibulocochlear nerve 469
- Vibration sense 506
- Viral hepatitis 308
- Virilism 644
- Viruses causing malignancy 726
- Visuospatial functions 436
- Vitamin 59
 A 59
 B₁ 63
 B₁₂ 65
 B₂ 63
 B₆ 64
- C 65
 D 60
 deficiency 60
 E 62
 K 62
- Voice sounds 218
- von Hippel Lindau syndrome 518
- W**
- Wasted leg syndrome 549
- Watershed areas of spinal cord 570
- Water-soluble vitamins 63
- WBC count 347
- Wegener's granulomatosis 718
- Whiplash or flexion extension injury 572
- White clot
 syndrome 388
 hypertension 89
- White nail 26
- Wilson's disease 330
- Withdrawal syndrome 772
- World Health Organisation classification 369
- X**
- Xeroderma pigmentosum 553
- X-linked
 ataxia 553
 dominant inheritance 44
 recessive inheritance 44
- X-ray hands 788
- Y**
- Yellow nail syndrome 26
- Young stroke 527
- Z**
- Zinc 69, 634
 deficiency 634
- Zollinger-Ellison syndrome 289